

NOTE:S

1. THE SLOTS AND TOP AND BOTTOM EDGES ARE AT 5 DEGREES
2. SIDES ARE MADE OF 3/4 "THK CLEAR PINE
3. SAND WOOD PRIOR TO ASSEMBLY
4. STAIN WITH GOLDEN OAK WOOD STAIN, SPRAY WITH VARNISH.
5. WHEN DRY, SAND AGAIN, SPRAY WITH PLEDGE AND SAND WITH 600 GRIT SANDPAPER FOR SOFT FINISH.
6. SCREW HOLES TO BE RECESSED AND PLUGGED WITH WOOD DOWEL.
7. WIDTH CANNOT EXCEED 12-3/4 IN.

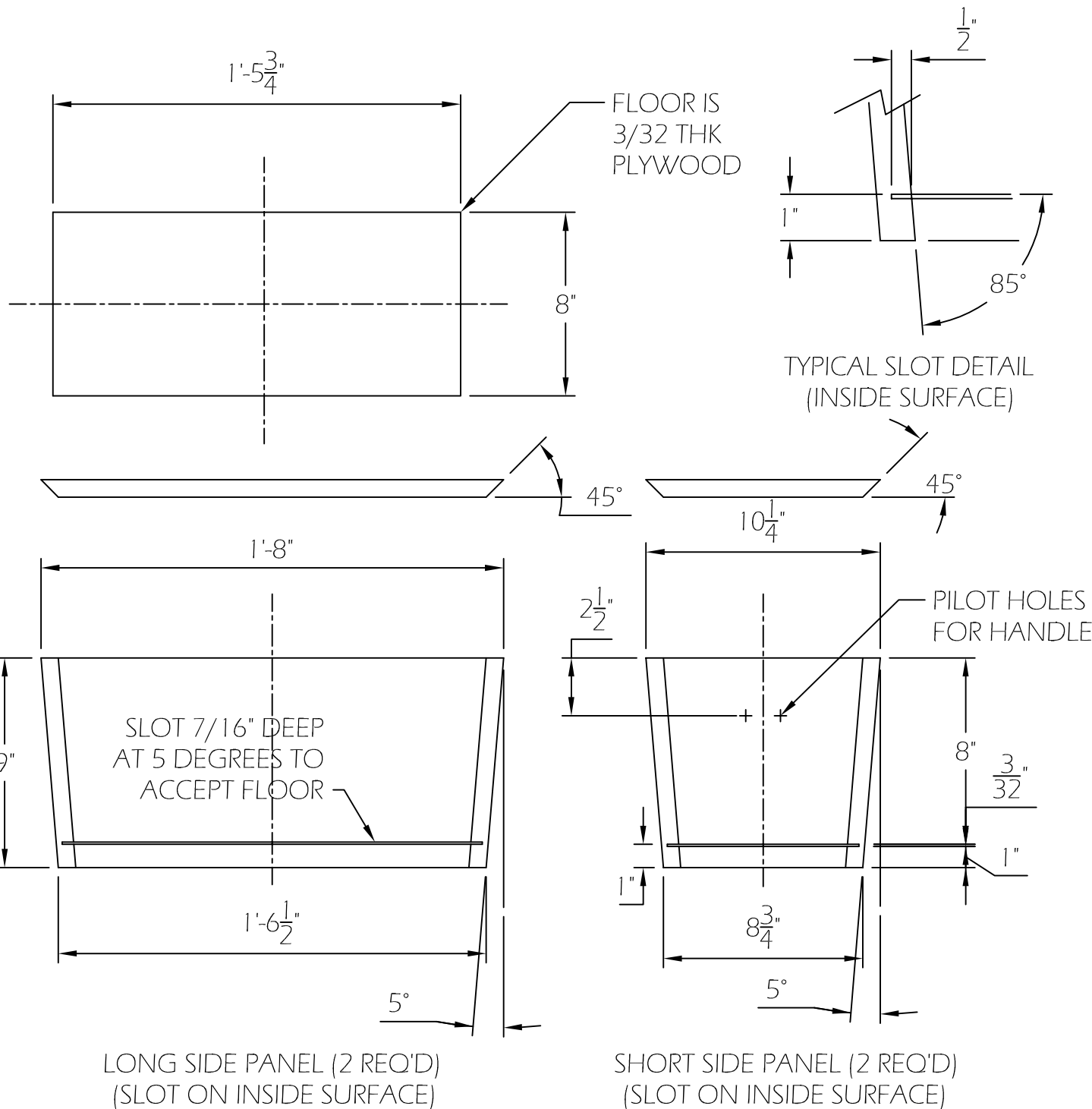

SMALL CASKET
FLOOR AND SIDES