

# WHOLE HOUSE

## iSpring WCFM550K Central Whole House Water Filtration System

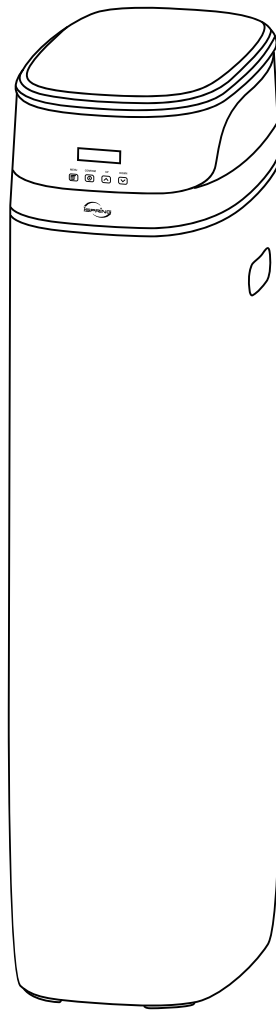

Model: WCFM550K

### Installation Instructions & User Manual

Ver. 05/2023



**iSpring** Water Systems

Any questions?  
Scan the QR code  
for support.



Copyright ©2005-2023 ISPRING WATER SYSTEMS, LLC. All rights reserved.





*We stand behind our products*

Since 2005, iSpring has been dedicated to providing high-quality drinking water to families across the United States. We provide various residential faucets and water filtration systems that purify your water in everyday life and deliver pure, healthy, and tasty water to you and your family.

At iSpring, we strive to develop products to the highest of standards and aim to make excellent drinking water accessible for all households. With affordable pricing, reliable quality, prompt delivery, and top-notch customer service, we hope to assist in bringing you great water for years to come.

## **Prior to Installation**

**Read this instruction manual carefully prior to installation.**

**Keep this manual readily available for future reference.**

## **Table of Contents**

User Information .....	3
Product Specifications .....	4
Packing List .....	5
General Product Information .....	5
Notice .....	6
<b><u>Installation</u></b>	
Installation Instructions .....	7
<b><u>Using the System</u></b>	
Programming the Central Water Filtration System .....	10
Operation Tips .....	13
Maintenance .....	13
Emergency Response .....	13
Troubleshooting .....	14
<b><u>Warranty</u></b>	
iSpring Standard Limited Warranty (End-Users Only) .....	
Warranty Registration Form .....	

## User Information

The user must adhere to the installation specifications described in this Product Installation and Operation Manual (hereinafter referred to as the "instruction manual"). iSpring is not responsible for damage, loss, or injury resulting from neglect, improper maintenance, or unauthorized modification of the unit.

- The unit should be placed only on flat surfaces. Do not mount on a wall.
- This product is designed for residential use only. Contact iSpring customer service to inquire about using in non-residential settings.
- The operating temperature range is 40°F - 100°F. If the water temperature or ambient temperature falls below 40°F, immediately shut off the inline water supply, turn off the inline water adapter, and drain the remaining water from the system. Failure of the water supply line or water purifier may result in malfunction, damage, and possible injury to the enclosure or water supply line.
- In case of malfunction due to damage or failure of the power supply system, unplug the system immediately and contact iSpring customer service.
- If leaking occurs, shut off the inline water supply by turning off the adapter. Then unplug the system and contact iSpring customer service.
- Use only authorized iSpring parts. Using unauthorized or aftermarket components will void the product warranty.
- This product is equipped with built-in systems to prevent internal leaks and minimize the risk of water damage. However, it is recommended that users check external fittings and connections regularly to ensure all components are secure.
- Unauthorized modification and disassembly are strictly prohibited and will void the warranty.
- Never touch the power cord connector when your hands are wet as this may result in electric shock.
- Product installation and use must strictly comply with the requirements of this manual. Do not perform any operation on the product without reading and understanding the contents of this manual.
- Activation of this product indicates that the owner has carefully read, understood, and accepted the contents of this manual, including the safety notices and instructions.

## Product Specifications

Though testing was performed under standard laboratory conditions, the actual performance of the system may vary based on local water conditions and quality.

<b>SPECIFICATIONS</b>	
Hydrostatic Test Pressure	350 psi (24.15 bar)
Inlet Working Pressure	35 - 100 psi
Inlet Water Temperature	40 - 100 °F (4 - 38 °C)
Water pH Range	5.8 - 10.5
Electrical Adapter	Input: AC120V, 60Hz; Output: AC12V, 650mA;
Pressure Tank Thread	2 1/2" NPSM
Inlet/Outlet Connector	1" NPT or 3/4" NPT
Effective Life	7-10 years
Service Flow Rate	Up to 12 GPM
Backwash Flow Rate	Up to 26 GPM
Pressure Drop	Up to 7 psi
Capacity	Iron: up to 20,000 gallons at 1 ppm conc.; up to 12 ppm conc. Manganese: up to 20,000 gallons at 0.5 ppm conc. Hydrogen Sulfide: up to 20,000 gallons at 0.2 ppm conc. Up to 20 ppm conc. of Manganese and Hydrogen Sulfide
<p>Note:</p> <ul style="list-style-type: none"> <li>• Do not use water that is microbiologically unsafe or of unknown quality without disinfection before or after use with this system.</li> <li>• Remove phosphate before the system. Adding phosphate compounds is not recommended before any oxidation-based iron removal technology.</li> <li>• This media is designed to remove Iron, Manganese, and Hydrogen Sulfide (Inorganic). Organic contaminants in water can cause deterioration of the media surface and, therefore, ineffective removal of Iron, Manganese, and Hydrogen Sulfide.</li> </ul>	

- Performance data was tested under standard laboratory conditions; actual performance may vary.
- This system is designed to be used on a cold supply ONLY and kept away from freezing environments.
- For very high concentrations of contaminants removal, it is recommended to use H<sub>2</sub>O<sub>2</sub> as an oxidant; conventional oxidants such as chlorine or potassium permanganate can also be used if required.
- All inlet and outlet pipes are recommended to use water pipes and fittings that meet the appropriate standards of domestic drinking water. The connection of water pipes and circuits should comply with national or industry standards, and the pipe connections should comply with relevant federal installation regulations.
- If the water inlet pressure is higher than 100 psi, a pressure-reducing valve must be installed at the water inlet pipe of the water purifier. If the water inlet pressure is lower than 35 psi, a booster pump must be installed at the water inlet pipe of the water purifier to ensure the working pressure meets technical requirements. In addition, a pressure-reducing valve or booster pump should be installed between the water inlet pipe and the water supply pipe of this product.
- If the temperature of the inlet water is higher or lower than the requirement, heat preservation measures should be executed.
- For satisfactory operation, the pumping rate of the well system must equal or exceed the indicated backwash flow rate.

## Packing List

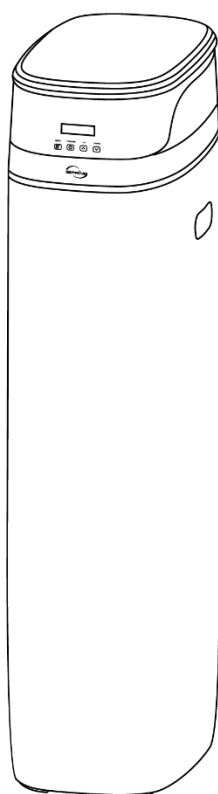

System



Stainless Steel Clamps



Hex Key

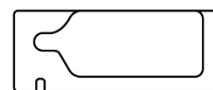

Silicone Lubricant

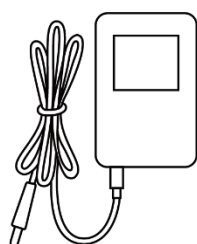

Power Adapter

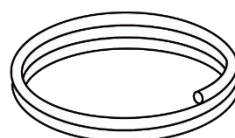

Drain Tube



Connect Screws  
(Model#: 3/4" NPT & 1" NPT)

## General Product Information

The Central Whole House Water Filtration System is designed for use whenever iron is problematic in the water supply. When water enters the Central Whole House Water Filtration System, it passes through a pocket of compressed air that incorporates oxygen. The water then passes through a filter bed, creating a reaction that separates the iron particles from the water. The Central Whole House Water Filtration System catches the iron particles, leaving iron-free water for use in all water applications. The automatic back flush system is designed to flush and wash the filter media and move pollutants to the drain.

There are three main working stages for this system as shown below.

- 1) **Service:** After the machine filters the pipeline water, it can provide drinking water per specifications.
- 2) **Backwash:** Backwash can remove the impurities remaining in the upper layer of the filter material and the toxic and harmful substances adsorbed in the filter material, restore the performance of the filter material, extend the life of the filter material, and prevent filter media from re-entering the water and compromising the water quality.
- 3) **Air-Draw:** Provide oxygen for iron oxidation and help with the iron and manganese precipitation process.

The main functions of this system are listed below.

- Fully Automatic Control
- Daily Reserve
- Smart Cleaning
- Metric format and US format are available to meet the different customers' requirements
- Multi-Language Function
- Continuous water monitoring
- The regeneration cycle can be set according to time or treated water volume.
- Arbitrarily set the start time of the regeneration process.
- Cycle function programming

## **Notice**

### **⚠Warning**

- This system can only be used with 120V/60Hz unidirectional AC power.
- Do not place objects on top of the power cord and set the unit in an area where the power cord will not be stepped on or tripped over.
- Electric shock hazard: Do not overload sockets or extension cords.
- If there is smoke, abnormal odor, or abnormal noise coming from the machine, immediately unplug the system's power to avoid fire or electric shock.
- Do not touch the plug with wet hands to prevent electric shock.

### **(1) Location**

- This system is required to be installed indoors. The installation location should be well-ventilated and protected against wind and rain. Avoid direct sunlight and radiation from any heat sources. A water leakage protection is highly recommended to be installed together with the system. If it needs to be installed outdoors, heat preservation measures must be taken for the body and pipes, including frost-proof, sun-proof, and waterproofing measures and insulation.
- The system's power supply and plug must be installed in a wall position higher than 500 mm above the ground and equipped with proper grounding, leakage protection, and waterproof devices.
- The installation location should be level, and the ground bearing capacity should be greater than 300 kg/m<sup>2</sup>.
- Ensure that there is proper space around the system and do not apply any external force to the system or its connecting pipes.
- Do not install this system near corrosive substances or gases, as this may cause the system to corrode.
- This system should be installed out of reach of children.
- Install this system after any sediment filters or neutralizing filters, if applicable.
- This system should be installed before a water softener or any taste/odor removal filters (if applicable).

### **(2) Media**

- Do NOT exchange pressure vessel media from one pressure vessel to another. Reason for inadequate sanitation during media exchange. Wet media absorb nitrogen and oxygen in the air, which immediately promotes bacterial growth. Biofouling on the surface of the media and other contaminants are present during the exchange. The media is only designed for iron manganese,

hydrogen sulfide, and other heavy metals. Media containing biofouling cannot be reused because it harms drinking water.

- The energy of the media is very aggressive at system startup and calms down by continuously backwashing the system for 1 to 2 hours. It retains enough buffering capacity when it reaches a stable pH of 8 to 10.

### (3) Others

- This equipment should never be tilted or placed horizontally during transportation, installation, or use.
- This drain tube and sewage pipe should remain open at all times.
- Do not place flammable items on or near the product.
- The installation and commissioning of all machines can be conducted by yourself or a professional technician.

## Installation Instructions

### (1) General Bypass

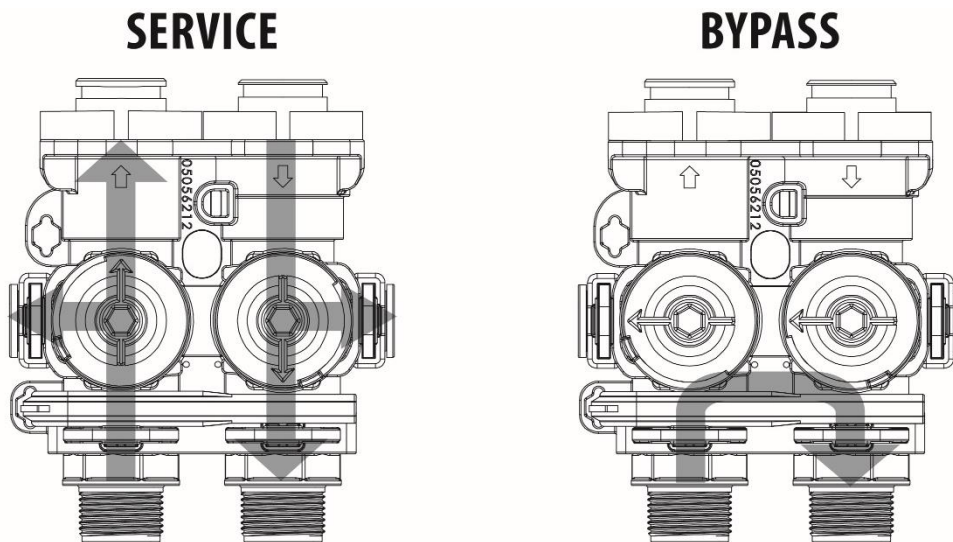

- a. Use the hex key to rotate the bypass valve. The water supply will be **bypassed** when the directions are **horizontal**. The bypass valve is in **service** when directions are oriented **vertically**. When the bypass valve is in service, users can take raw water and filter water samples for testing at the water taking port on either side of the bypass.
- b. In case of equipment failure or other exceptional circumstances, the bypass can be adjusted to the bypass position, allowing users to directly use tap water temporarily. After the failure or problem is resolved, adjust the bypass to the vertical service position.

### (2) Before Installation

- Ensure the installation environment meets all the requirements in Product Specifications section (see page 4).
- When connecting screw parts, seal rings are generally installed. Please be aware that excessive force may cause the threads to slip and the screw to crack.
- Do not remove the clips when the system is in operation; relieve the pressure before removing the clips.

### (3) Installation Steps

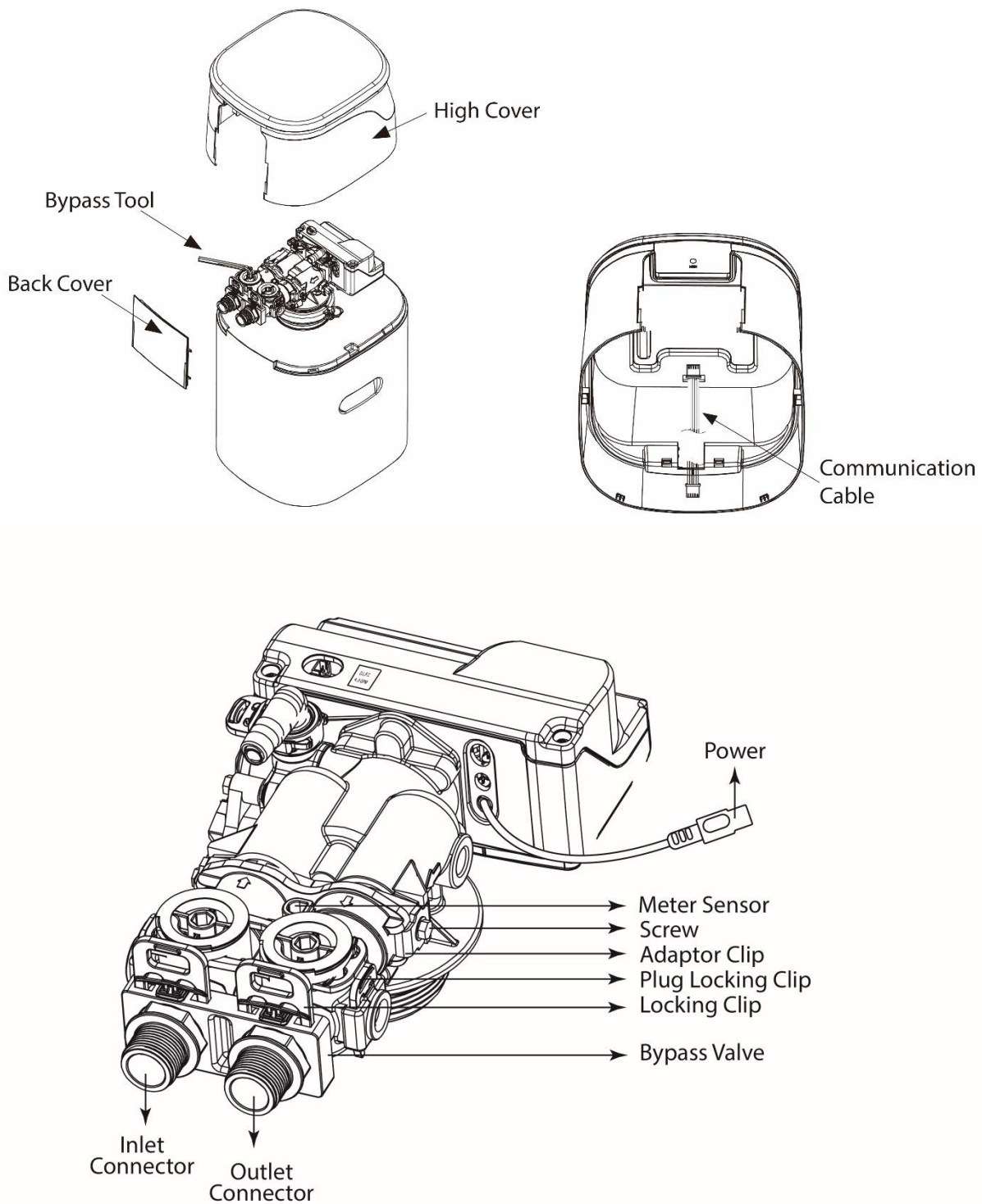

It is highly recommended that you watch the video *DIY installation and Operation Guide / iSpring WCFM550K Whole House Water Filtration System* on YouTube.

**Step 1.** Confirm proper installation conditions, unpack the equipment and verify that all accessories are present. Prepare the installation tools and confirm that the installation site's water inlet and outlet pipes, power supplies, drain tube, and floor drain meet the appropriate requirements.

**Step 2.** Remove the back cover and the high cover. Disconnect the communication cable.

- Step 3.** A pair of 1" connect screws and a pair of 3/4" connect screws are included in the package. **Lubricate** the inlet/outlet connect screw **o-rings**. Connect two one-inch quick-connectors, pull out the clamps, insert the quick-connectors into the water inlet and outlet, and re-insert the clamp. Use only **food-grade/included silicone lubricant**.
- Step 4.** **Close the main water supply** completely, then **open any faucets** in the room to remove the remaining water in the indoor water pipe.
- Step 5.** **Connect** the water **inlet** and **outlet** pipes of the system to the pipeline. Double check the direction of the water flow matches the sign on the system. Pay attention to the pipeline's height and placement angle when connected to prevent the connection pipes from bearing stress. While connecting pipes, keep the pipes as close to the wall as possible. The routing of the pipes should be straight, and the corners should be clear. The pipes should be fixed on the wall after installation.
- Step 6.** **Connect** the **drain** hose and **clamp** to the system tightly to ensure a secure connection. The other end of the drain hose goes to the **sewage** pipe. There must be sufficient space (~10 cm) between the outlet of the drain hose and the sewage level to prevent sewage from flowing back to the product. The sewage pipe should be 30 cm higher than the ground, and the drain hose should be fixed on the sewage pipe.
- Step 7.** Plug in the **power adapter** and connect the other end of the socket to supply power to the system.
- Step 8.** Rotate the bypass valve to the **bypass position**.
- Step 9.** Slowly **turn on the main water supply**.
- Step 10.** **Open a cold water tap** nearby and let the water run for a few minutes till the water runs clean or until the system is free of foreign material caused by plumbing work.
- Step 11.** Then, slowly **open the water inlet** on the bypass valve (the valve should be opened at an angle of about 45°), and fully **open the water outlet**. Let the water run until the air is purged from the unit. Then **close the tap**. The air in the tank is then exhausted until it is full.
- Step 12.** Rotate the bypass valve to the **service position** and observe whether there is water leakage or any other leakage at each connection. After ensuring safety, rotate the bypass valve to the **bypass position** and **soak** the filter material for **35 minutes**.
- Step 13.** Fully **open the water inlet** on the bypass valve. Install the high cover, connect the communication cable. Next, **perform Default Regeneration Cycle (45 minutes) immediately once or twice.**
- ✚ All keys will lock after 3 minutes during the standby status. Press and hold the "MENU" key for 3 seconds to unlock.
- Step 13. a.** To perform the **Regeneration Cycle**, press and hold the "CONFIRM" button for 3 seconds to enter the manual regeneration mode and choose **IMMEDIATELY** regeneration.
- Step 13. b.** Backwash (15 minutes)
- Step 13. c.** Air-Draw (30 minutes)
- Step 13. d.** Unit Returns to the In-Service Position
- Step 14.** Rotate the bypass valve to the **service position**, and install the back cover.
- Step 15.** **Open a cold water tap** nearby and let the water run for at least 5 minutes or until the water is clear. Then **close the tap**. Verify the water is completely clear before use.
- Step 16.** Check again for any water leakage in the pipeline and whether the fittings at the connection parts with the original pipeline cause loosening or water seepage from construction.
- Step 17.** Set up the system parameters of the equipment (see **Programming the Central Water Filtration System** for details, page 10-12).
- Step 18.** Clean the installation site.

# Programming the Central Water Filtration System

## A. Button Configuration

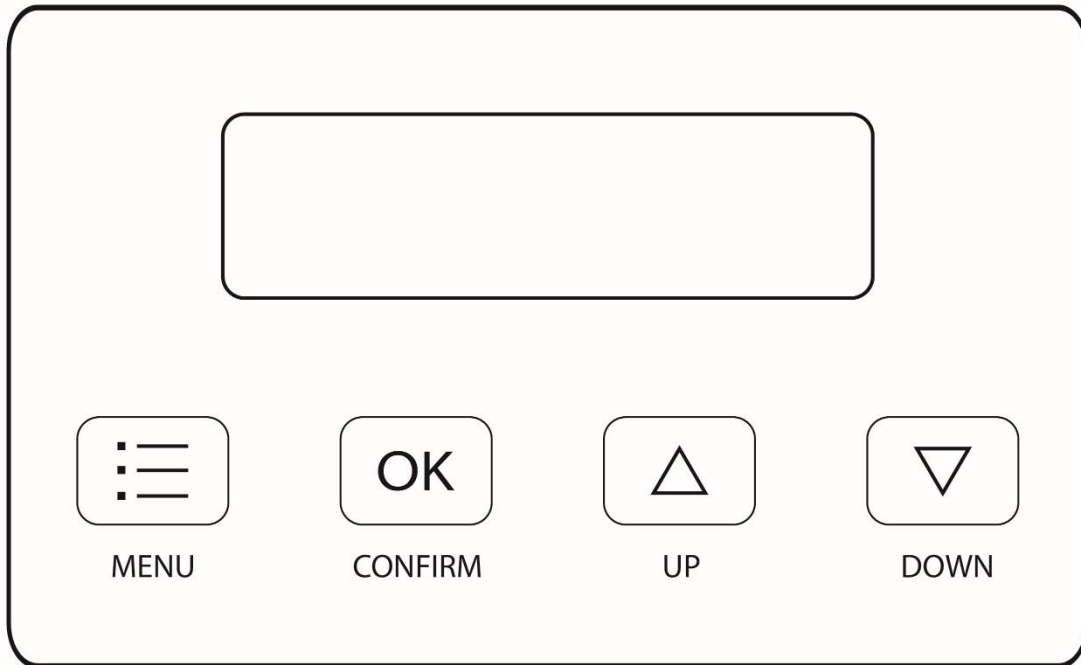

- a. "MENU"  
This function is used to enter the basic setup information required during installation.
  - Press and hold the key for 3 seconds to unlock the device while in standby mode.
  - In the user menu setting, press this button to immediately exit the menu.
- b. "CONFIRM"  
This function is used to initiate an immediate or delayed manual regeneration.
  - In the user menu setting, press this button once to confirm the parameter setting and switch to the next option.
- c. "UP" / "DOWN"  
These buttons are used to increase or decrease the value of the settings while in programming mode.
  - When the display is in a menu option, these keys can be used to adjust the value or option.

## B. Notes

- a. During the menu setting process, if there is no activity within 1 minute, the system will automatically return to the standby state.
- b. All keys will lock after 3 minutes during the standby status. Press and hold the "MENU" key for 3 seconds to unlock.

## C. Programming Levels

There are four levels of the valve program:

**a. Settings**

Press and hold "MENU" for 3 seconds to enter.

Use the "UP" and "DOWN" button to modify the value. Press the "MENU" button once to confirm and switch to the following parameter setting, the entire menu shown below. Press "CONFIRM" to immediately return to the standby state.

TIME OF DAY 12:01 PM
YEAR 2012
MONTH AUGUST
REGEN DAYS 7 DAYS
GALLONS 2114 GAL
REGEN. TIME 02:00 AM
LOAD DEFAULT NO
PROGRAMMING COMPLETE

**TIME OF DAY, YEAR, MONTH, DAY:**

Time of day is for normal operation of system and the scheduling of the regeneration time. The date is used in a diagnostic function to track the last time the system regenerated.

**REGEN. DAYS:**

The number of days between regenerations or back washes to clean the filters. The user can set the number of days in the regeneration cycle according to the water situation.

**METERS:**

Default value is "2114 GAL". Adjust the METERS to set the capacity. This will cause the unit to regenerate either when the gallons remaining goes to zero or the days between regeneration is zero. Which ever occurs first.

**REGEN. TIME:**

Determines the time of day to perform a scheduled regeneration. You can set the system's regeneration time according to your routine. It is recommended to set it in a period when water is not in use. The system defaults to 02:00 a.m.

**LOAD DEFAULT:**

If the selection is made, the processing time of each regeneration cycle will be reset to the default value setting. The rinse time will return to the default value.

**b. Advanced Options**

Press and hold "UP" and "DOWN" at the same time for 3 seconds to enter.

Press "CONFIRM" to confirm and switch to the following parameter setting, the entire menu shown below. Use the "UP" and "DOWN" button to modify the value. Press the "MENU" button to immediately return to the standby state.

VALVE MODE CHEMFREE-AIR
BACKWASH 15 MINUTES
AIR-DRAW 30 MINUTES
LOCK VALUE UNLOCK
PROGRAMMING COMPLETE

**BACK WASH DURATION / AIR-DRAW DURATION:**

Users can adjust these parameters at any time with the help of an application engineer based on the water environment.

**LOCK VALUE:**

This setting locks the value set in this previous page, and the end user will not be able to modify it before this setting is changed to UNLOCK.

**c. Factory Options**

Press and hold "MENU" and "CONFIRM" at the same time for 3 seconds to enter. Press "CONFIRM" to confirm and switch to the following parameter setting, the entire menu shown below. Use the "UP" and "DOWN" button to modify the value. Press the "MENU" button to immediately return to the standby state.

**LANGUAGE**  
ENGLISH  
FRENCH

**UNITS**  
GALLONS  
METRIC

**SMART CLEAN**  
OFF

**PROGRAMMING**  
COMPLETE

**SYSTEM LANGUAGE:**  
Choose the system language.

**UNITS:**  
Choose the system unit of measurement: metric or gallons.

**SMART CLEAN:**  
When set to ON, the system will perform a 10 (adjustable) minute backwash and rinse if there is no water flow detected after 7 (adjustable) days. The regeneration will occur at the scheduled REGEN TIME.

**d. Regeneration Mode Options**

Press "CONFIRM" button once to enter "DELAYED REGEN." function. Use the "UP" and "DOWN" button to change the mode. Press "CONFIRM" to confirm the setting. Press the "MENU" button to immediately return to the standby state.

**DELAYED REGEN.**  
OFF

**DELAYED REGENERATION**  
In this mode, the system will start a regeneration at the next regeneration time regardless of the remaining regeneration days or water consumption.

Press and hold the "CONFIRM" button for 3 seconds to enter the "REGENERATION" setting. Use the "UP" and "DOWN" button to switch the modes. Press "CONFIRM" to confirm the setting. Press the "MENU" button to immediately return to the standby state.

**REGENERATION**  
IMMEDIATELY

**REGENERATION**  
VACATION MODE

**IMMEDIATE REGENERATION**  
Under this mode, the system immediately starts a regeneration.

**VACATION MODE**  
Choose vacation mode and input estimated holiday days; the valve will regenerate in a SMART CLEAN mode. The system will remain in vacation mode when no water is used during the input estimated holiday days; if there's water used, the vacation mode will be auto-off, and the system will return to the normal working mode.

## **Operation Tips**

- The product can be generally used after installation and commissioning have been completed. With an uninterrupted power supply, the user does not need to perform other operations on the machine.
- The automatic regeneration start time default is to start late at night. The water is not treated and should not be used during this time.
- During the use of the system, do not cut off the power to avoid errors in the clock on the system, which will affect the original regeneration start time and lead to the potential use of untreated water.
- When the water supply is shut down, the system should be in the bypass position. When the water supply is restored, the faucet in the home should be opened first. When the water supply is restored after the water supply is shut down, pollutants in the water pipe may enter the system and damage the machine, leading to filter failure. The contaminated water should be released, and the system should return to the service position after the water runs clear.
- DO NOT regenerate any other softeners/filters at the same time as this system since this will interfere with the regeneration process and cause damage.
- For high water usage and/or high iron levels conditions, the system may need to increase the regeneration frequency compared to the regular setting. The regeneration frequency can be increased to once per day or every two days, depending on the users' situation. The system needs to be regenerated at least once per three days as the filter medium can become fouled with iron, rendering the unit ineffective.

## **Maintenance**

- Regularly get your water tested to ensure the system is working properly.
- Media needs to be refilled only when the system reaches capacity or accidentally gets contaminated. The media replacement process needs to be conducted with a professional or under professional guidance. For related questions, contact the iSpring Customer service team.
- Systems installed outdoors without regular maintenance will fail sooner than those installed indoors. It is recommended that you check the product and maintain it regularly. Call us immediately if anything goes wrong.

## **Emergency Response**

- If the equipment fails or experiences other exceptional circumstances, the inlet and outlet valves can be closed (bypass position), and the municipal water supply can be used directly. Re-open the system's water inlet and outlet valves once the emergency is fixed.
- If water consumption increases significantly (compared to normal usage) or the quality of raw water decreases, the number of regenerations should be increased accordingly.
- During the process of system regeneration, if the system experiences a power loss, more than one discharge may occur, resulting in the waste of water resources.
- In case of power failure, readjust the current time and regeneration start time according to the manual after the power supply is restored.
- When the water supply in a residential area is shut down, the main water main valve should be closed immediately. The municipal water supply may cause negative pressure on the household pipeline and damage the equipment.

If you have any questions or concerns during the installation, please contact us at [support@123filter.com](mailto:support@123filter.com) or visit our help page at [123filter.com/support](https://123filter.com/support)

## Troubleshooting

ISSUE	POSSIBLE CAUSE	POSSIBLE SOLUTION
<i>Unit fails to initiate a regeneration cycle</i>	No power supply	Check electrical service, fuse, etc.
	Power failure	Reset time.
<i>Low water pressure</i>	Iron buildup in line to the unit	Clean pipes.
	Iron buildup in the unit	Clean the control valve. Increase frequency of regeneration.
	Inlet of control plugged due to foreign material	Remove the piston and clean the control valve.
<i>Control valve without display</i>	Power failure, the power adapter is not plugged in	Check the power supply to ensure regular or restored power supply.
	Power off while regeneration	Turn the bypass valve to the bypass position or close the control valve.
	Control valve failure	Contact us.
<i>Poor water quality</i>	The Control valve clock is inaccurate due to a power failure, causing the regeneration start time to be changed	Adjust the control valve's current time. For operating procedures, refer to the current time in the control valve manual.
	Poor source water quality	Add an additional regeneration process. Refer to the setting of the regeneration cycle in the control valve manual for the operating procedure.
	Filter failure	Contact us.
	Regenerate too often or too little	The regeneration cycle setting is not optimal. Adjust the regeneration cycle of the control valve and refer to the setting of the regeneration cycle in the control valve manual for the operating procedure.
	Incoming water quality does not meet national municipal tap water standards	Contact the relevant local water supply department or add WSP series, WGB series before the system.
	Water system pressure is too low or too high	Install pressure stabilization equipment.
<i>Filter material performance reduce</i>	Control valve failure	Contact us.
	The backwash flow rate is too large or too small	Verify the water pressure is in the range of 35-100 psi.
<i>Regeneration start time is incorrect</i>	The control valve is inaccurate due to power failure	Adjust the current time of the control valve.
	The regeneration start time is set incorrectly	Adjust regeneration start time. For operating procedures, refer to the current time in the control valve manual.
<i>Iron in conditioned water.</i>	Fouled mineral bed.	Check backwash. Increase frequency of regeneration. Increase backwash time.

## **iSpring Standard Limited Warranty (End-Users Only)**

**In order to be eligible for this warranty, the end-user must register at [www.123filter.com](http://www.123filter.com).**

For all water filtration systems, and upon registration by the end-user, iSpring Water Systems, LLC (iSpring) warrants for a one year from the date of purchase that the product is free of defects in materials and workmanship and that it will function for the duration of the warranty according to its specifications (the "Limited Warranty"). EXCEPT FOR THIS LIMITED WARRANTY, ISPRING EXPRESSLY DISCLAIMS ANY AND ALL REPRESENTATIONS AND WARRANTIES, WHETHER EXPRESS, IMPLIED, OR STATUTORY, INCLUDING ANY WARRANTIES OF TITLE, NON-INFRINGEMENT, MERCHANTABILITY OR FITNESS FOR A PARTICULAR PURPOSE. iSpring has no liability for any defect or deterioration which results from the improper installation, service, repair or use of the product. End-user's sole and exclusive remedy for any breach of the Limited Warranty shall be repair or replacement, at iSpring's option and expense. This warranty is only provided to end-users and only applies to products purchased directly from an authorized iSpring dealer or reseller.

### **Warranty Registration**

iSpring does not have access to order information from 3rd party selling channels, and it is strongly recommended to manually fill in the order information upon registering for warranty. Please contact our support team at [support@123filter.com](mailto:support@123filter.com) if there are any questions or concerns about the product and its installation. Your satisfaction is our business!

Please consider supporting us by leaving an honest product review on the channel where the product was purchased. It means a lot to us. Thank you for being an iSpring customer.

# Warranty Registration Form

Name \_\_\_\_\_ Order# \_\_\_\_\_

Email \_\_\_\_\_ Phone \_\_\_\_\_

Address \_\_\_\_\_

City \_\_\_\_\_ State \_\_\_\_\_ Zip Code \_\_\_\_\_

Model #/ Serial Number

\_\_\_\_\_

Purchased at (e.g. Amazon, Home Depot)

\_\_\_\_\_

Send to:

iSpring Water Systems, LLC  
2480 Industrial Park Blvd, Cumming, GA 30041  
+1 (678) 261-7611

Plumber's information (Optional)

To best serve our customers, we'd like to recommend good plumbers throughout the USA. If you are happy with your installer, please provide their information so that we can pass it on as a courtesy.

Thank you!

Name of the plumbing company used to install your system:

\_\_\_\_\_

Phone #: (\_\_\_\_\_) - \_\_\_\_\_ or email : \_\_\_\_\_  
of the technician.





Like our products?

Please show your support by writing a product review on the marketplace where you make your purchase. Even just a quick statement means a lot to us.

Thank you!

**iSpringFilter.com**



Scan to get your FREE warranty

For questions, comments, or technical support, please contact us at:

✉ [support@123filter.com](mailto:support@123filter.com)

☎ +1 (678) 261-7611

💬 +1 (470) 560-0012

Monday-Friday 9:00 a.m. - 5:00 p.m. EST

**Water's Good®**

