

AprilAire

Dehumidifier

SUBMITTAL

Model E080

Dehumidifier

Project: _____

Architect: _____

Contractor: _____

Suppliers: _____

Dealer: _____

Engineer: _____

Location: _____

Date: _____

SPECIFICATIONS

Capacity⁽¹⁾	@ 80°F/60% RH @ 73°F/60% RH	80 ppd 65 ppd
Energy Factor⁽¹⁾	@ 80°F/60% RH @ 73°F/60% RH	2.8 L/kW-h 2.35 L/kW-h
Airflow @ varying E.S.P. (external static pressure - dry coil)	0.0" w.c. 0.2" w.c. 0.4" w.c.	185 CFM 135 CFM 85 CFM
Voltage, phase, frequency	120 VAC, 1 Phase, 60Hz	
Current draw⁽¹⁾	4.8 Amps	
Noise	45 dBA ducted	
Dimensions (cabinet only)⁽²⁾	Width: 14" Height: 15" Length: 26"	
Unit Weight	63 lbs.	
Shipping Weight	81 lbs.	
Control⁽³⁾	Built-in digital control with display	
Control mounting option	Top or front-mounting options	
Cabinet insulation	1/2" EPS	
Air discharge orientation	Top or end	
Inlet/Outlet duct collars	10" dia.	
Backdraft damper at outlet	Included	
Filter	Washable MERV 8 (Part Number 5881)	
Refrigerant	R32	
Coil type	Corrosion-resistant aluminum	
8' Power cord⁽⁴⁾	Plug type (E080 only)	
Hardwire option	Yes, (E080H only)	
Discharge air temperature rise	10°F-30°F	
Drain connection⁽⁵⁾	3/4" MNPT Threaded	
Warranty	5 Years on all parts	



E-series



**Most Efficient
2025**
www.energystar.gov

MODELS:

E080: Includes 8' power cord

E080H: Terminal connection for hardwiring

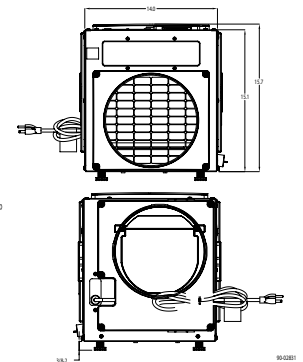
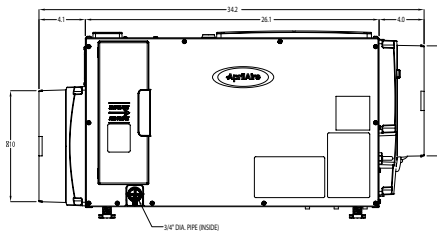

OPERATION

The AprilAire E080 Dehumidifiers are designed to dehumidify the air coming into the unit by passing the incoming air over an evaporator coil, dropping the air temperature below the dew point. The moisture is removed from the air and drains out of the dehumidifier to a common floor or waste drain. The air is then reheated in the condenser coil and exits the unit.

Dehumidification occurs until the relative humidity (%RH) setting is reached. The unit then shuts off until periodic sampling determines the need for dehumidification. The integrated digital display and control monitors the %RH during sampling of the incoming room or HVAC return air.

APPLICATION

The E080 Dehumidifiers are the perfect product for whole-home dehumidification, basements, crawl spaces and sealed attics.

VENTILATION

The E080 has the ability to bring in fresh, outdoor air into the living space. Fresh air will dilute stale air and pollutants and will reduce humidity in the winter months. If the humidity level of the outdoor air higher than the %RH setting, the dehumidifier will begin dehumidification to reduce the humidity in the home to set humidity level. The outdoor fresh air is brought in through 6" round duct with a 6" round, normally closed damper. This complies with ASHRAE 62.2, Energy Star, and International Residential Code (IRC).

The dehumidifier has built-in controls to adjust the amount of fresh air that is brought in to the home. If wired to the HVAC system, the dehumidifier will bring in the outdoor air when the HVAC system calls for heating, cooling, or is running continuous fan. If the amount of set ventilation time has not been met during the HVAC calls, the dehumidifier will open the ventilation damper and turn on the HVAC fan and bring in fresh air until the ventilation time has been met.

High and low temperature limits are available in 3 different modes, preventing outdoor air that is too hot or too cold from being delivered to the home. If the outdoor temperature rises above the high limit or drops below the low limit, ventilation will not occur. If the outdoor temperature drops below the heat only limit, ventilation will be allowed only when the HVAC system is calling for heat. A high indoor %RH limit is also available in all three ventilation modes.

ZONED DEHUMIDIFICATION

The E080 Dehumidifiers are capable of zoned dehumidification. In this application, the dehumidifier can control the humidity in two separate zones in the home, a Primary and Secondary Zone.

The submittal is intended to show general, overall product dimensions and provide guidance for installation clearance. Drawings are not to scale. Ensure submittals are current. AprilAire reserves the right to make product changes without notification or obligation.

⁽¹⁾Rated capacity, energy factor and current draw measured at 80°F/60% RH inlet air at 0.0 ESP.

⁽²⁾Height does not include adjustable feet. The width excludes the filter doors and length excludes the duct collars.

⁽³⁾Built-in automatic control capable to be set up for dehumidification and ventilation or zoning.

⁽⁴⁾Model E130H is a hardwired unit and doesn't ship with a power cord.

⁽⁵⁾Threaded barbed fitting included



5-year warranty on all installed products
(warranty does not apply to filters)

DESIGNED & ASSEMBLED IN THE USA
UTILIZING U.S. AND GLOBAL COMPONENTS