



ZTR6200

Battery Powered Exposed Sensor Flush Valve for Water Closets

TAG _____

Architectural/Engineering Specification:

Exposed, quiet piston-type, chrome plated flushometer valve with a polished exterior. Complete with chloramine resistant, filtered piston kit. The valve incorporates a battery powered solenoid actuator, automatic sensor with manual override push button, and robust vandal resistant metal cover with 10 degree angled sensor.

Product Features:

- Proprietary Dezincification resistant low lead brass alloy
- Control Stop has internal siphon-guard protection and vandal resistant stop cap, Sweat solder kit, wall flange with set screw.
- High back pressure Vacuum Breaker with one piece hex coupling nut
- Chloramine resistant Internal seals
- Adjustable tailpiece
- Spud coupling and flange for top spud connection

Compliance and Certification:

- ADA Compliant - Operational Controls



*This product should be used with a WaterSense labeled counterpart with a compatible flush volume to ensure that the entire system meets the requirements for water efficiency and performance.

WHEN INSTALLING IN A HANDICAP STALL:

Per the ADA Guidelines (section 604.9.4) it is recommended that the grab bars be split or shifted to the wide side of the stall. If grab bars must be present over the valve, use the alternate ADA installation as shown on the next page.



Flow Options:

	Flush Volume gpf [Lpf]	Dual Flush	WaterSense Labeled*
-ONE	1.1 gpf [4.1 Lpf]		✓
-EV	1.28 gpf [4.8 Lpf]		✓
-WS1	1.6 gpf [6.1 Lpf]	1.6/1.1 Gpf [6.1/4.1 Lpf]	

Note: Dual Flush feature has 60 second threshold

Suffix Options:

- DF Dual Flush Option (See Chart Above)
- FM12 Floor Mount 12" Rough In
- LL 10 Year Long Life Battery
- YJ Split Ring Pipe Support
- YK Solid Ring Pipe Support

Valve Height Options:

	A
Standard	11 1/2" [292]
-1	16" [406]
-2	24" [610]
-3	27" [686]

Architectural/Engineering Approval

The information contained in this document is subject to change without notice. Please contact Zurn for most up to date information.

Rough-in/Overview dimensions

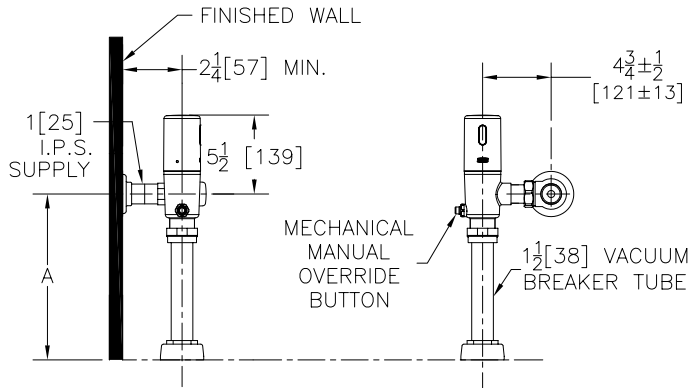

Alternate ADA Installation

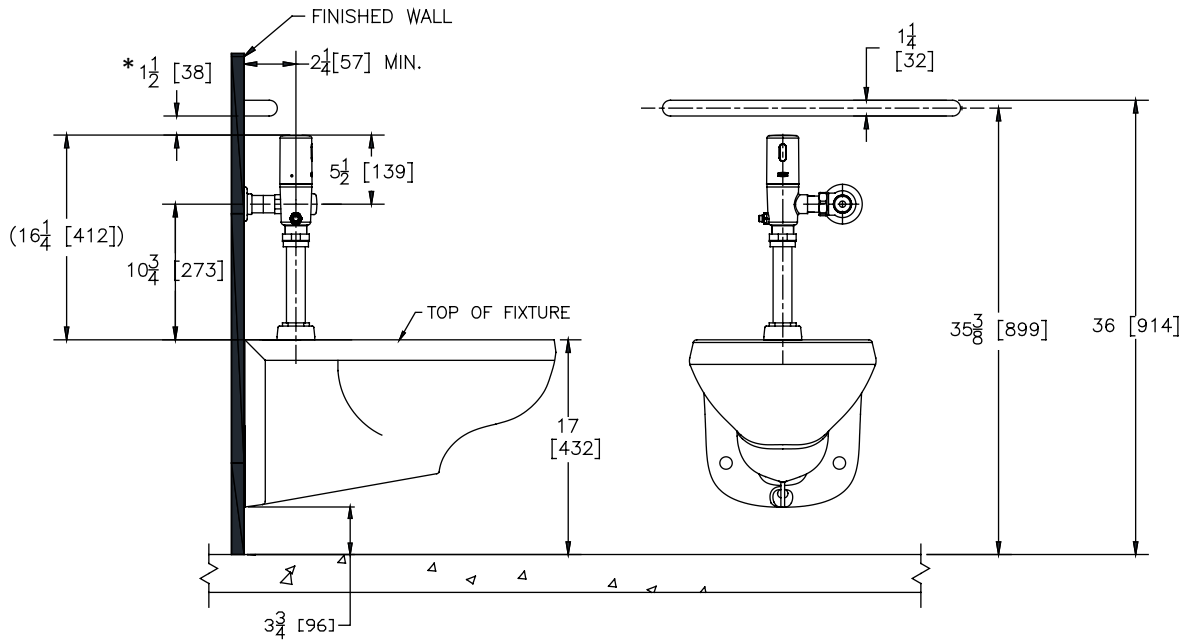

- Water supply rough-in to 10 3/4" (minimum) with grab bar at 36".
- ADA compliance met using 1 1/4" grab bar as shown.
- *ADA compliant minimum gap between wall and grab bar 1 1/2".
- Does not meet California ADA compliance for grab bar height (33" grab bar centerline required)