

AQUASPEC[®] FAUCETS

MODEL - Z87100-XL SERIES
Z87100-XL-HS SERIES
KITCHEN SINK FAUCET



TECHNICAL INFORMATION

FLOW: 2.2 GPM [8.3 L] PRESSURE COMPENSATING AERATOR

MAXIMUM PRESSURE: 125 PSI

MAXIMUM TEMPERATURE: 180°F

HANDLE NUT TORQUE: 15-20 FT-LBS

CARTRIDGE STYLE: QUARTER TURN CERAMIC DISK

**OTHER AERATORS AVAILABLE BY REQUEST*

⚠ WARNING: Cancer and Reproductive Harm - www.P65Warnings.ca.gov

⚠ ADVERTENCIA: Cáncer y daño reproductivo - www.P65Warnings.ca.gov

⚠ AVERTISSEMENT: Cancer et effets néfastes sur la reproduction - www.P65Warnings.ca.gov

INSTALLATION INSTRUCTIONS

1. REMOVE FAUCET BODY(#6) FROM CARTON AND APPLY PLUMBERS PUTTY TO UNDERSIDE OF BODY. (REFER TO FIGURE 1).
 2. PLACE FAUCET ON SINK AND REMOVE MOUNTING NUTS (#7).
 3. HAND TIGHTEN MOUNTING NUTS (#7) FROM UNDER SINK. MAKE SURE FAUCET IS CENTERED PROPERLY. DO NOT OVER TIGHTEN.
 4. OPTIONAL HOSE SPRAY (REFER TO FIGURE 2). REMOVE HOSE SPRAY ASSEMBLY (#12) FROM PACKAGING. REMOVE MOUNTING NUT FROM HOSE SPRAY HOLDER (#12) AND INSERT HOSE SPRAY HOLDER THROUGH FIXTURE. ASSEMBLE MOUNTING NUT ONTO HOSE SPRAY HOLDER AND TIGHTEN. DO NOT OVER TIGHTEN. INSERT THREADED END OF HOSE SPRAY (#12) THROUGH HOSE SPRAY HOLDER (#12) AND CONNECT HOSE SPRAY (#12) TO DIVERTER ADAPTOR (#11). TIGHTEN TO CREATE A WATER TIGHT CONNECTION.
 5. ATTACH LAVATORY SUPPLIES TO FAUCET WITH RISER NUTS (ITEM #7B).
 6. OPTIONAL GRID STRAINER (-G) / HANDICAP OFFSET GRID DRAIN (-GH) INSTALL GRID STRAINER IN SINK OUTLET AND PLUMB WASTE CONNECTION.
 7. INSTALL SPOUT INTO BASE AND TIGHTEN NUT (SEE VIEWS FOR SWING/RIGID CONNECTION).
 8. TURN SUPPLY WATER ON AND OPERATE FAUCET CHECKING FOR LEAKS.
 9. REPLACE HANDLE SCREWS AND COLOR INDEX BUTTONS.
 10. INSTALL AERATOR INTO FAUCET AND HAND TIGHTEN. IT MAY BE NECESSARY TO UNSCREW AND CLEAN AERATOR AT START-UP.
-

MAINTENANCE

1. YOUR ZURN AQUASPEC FAUCET HAS A HIGHLY POLISHED NICKEL CHROME PLATED FINISH. CLEAN WITH SOAP AND WATER OR A MILD CLEANER WHICH IS SAFE FOR CHROME PLATING. DO NOT USE ACIDS OR TOILET BOWL CLEANER AS THEY WILL DAMAGE THE FINISH.
2. AQUASPEC FAUCETS CONTAIN CERAMIC DISK CARTRIDGES WHICH REQUIRE NO MAINTENANCE. TO REMOVE THE CARTRIDGE, SHUT THE WATER OFF, LOOSEN THE HANDLE NUTS AND PULL UP ON THE CARTRIDGE.

REPLACEMENT PARTS

COLD WATER CARTRIDGE
HOT WATER CARTRIDGE
INDEX BUTTONS

59517005
59517006
G60500

HOSE SPRAY AND HOLDER

G67905

Z871B1-XL PICTURED

Z871B1-XL-HS PICTURED

FIGURE 1

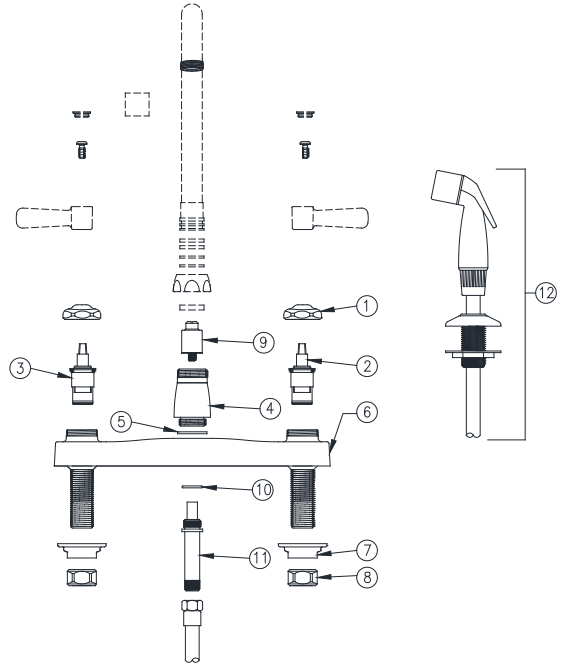
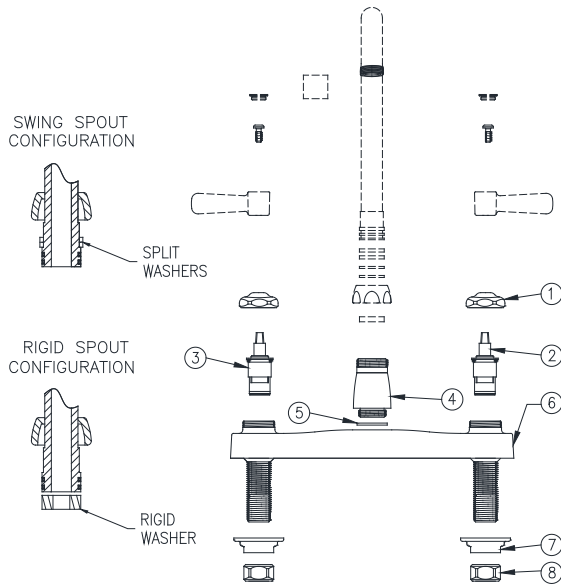

Item	Part Number	Description	Qty.
1	59440001	HANDLE NUT	2
2	59517005	SHORT COLD CARTRIDGE XL	1
3	59517006	SHORT HOT CARTRIDGE XL	1
4	60467005	BASE	1
5	58155019	O-RINGS	1
6	93286001	KITCHEN DECK BODY	1
7	G60502	NUTS	1

Item	Part Number	Description	Qty.
1	59440001	HANDLE NUT	2
2	59517005	SHORT COLD CARTRIDGE XL	1
3	59517006	SHORT HOT CARTRIDGE XL	1
4	60467005	BASE	1
5	58155019	O-RINGS	1
6	60545007	KITCHEN DECK BODY	1
7	G68042	MOUNTING NUTS (2 EACH)	1
8	G68043	RISER NUTS (2 EACH)	1
9	93217001	DIVERTER	1
10	58155015	O-RING	1
11	60943002	DIVERTER ADAPTER	1
12	G67905	HOSE SPRAY ASSEMBLY	1