

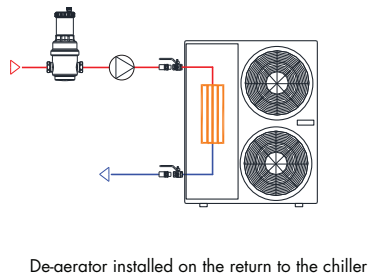

Installation

- Install on the warmest side of the system as this is the area where micro-bubbles form more easily.
- Install on the boiler outlet on heating systems and in the return pipe on cooling systems to chiller units.
- It is recommended to install isolating valves upstream and downstream of the de-aerator in order to allow for scheduled maintenance work and filter cleaning.
- The ZILMET micro-bubble de-aerator is bi-directional therefore it has the same efficiency irrespective of flow direction.
- The de-aerator must be installed vertically in horizontal pipework with the automatic air vent at the top.

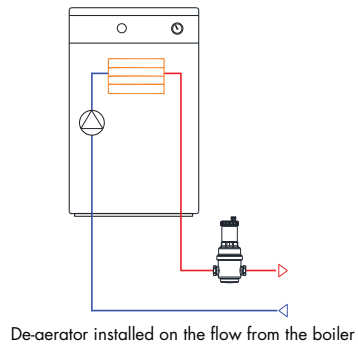
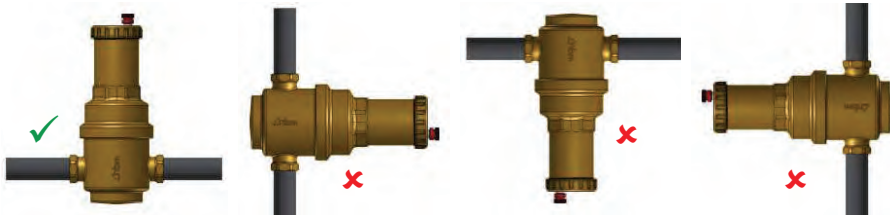

ZILMET USA
400 FRENCHTOWN ROAD
EAST GREENWICH
RI 02818

T. (401) 884 4943
E. INFO@ZILMETUSA.COM

WWW.ZILMETUSA.COM

5-27-2019

ZILMET Inline De-Aerator

Installation and Maintenance Instructions



Introduction

The ZILMET inline de-aerators are suitable of eliminating micro bubbles from heating and cooling systems in commercial and public buildings.

The de-aerators use two separate principles to operate.

ACTIVE: The area where micro-bubbles are formed as a result of strong turbulence and swirling motion. Micro-bubbles collect together to form bigger bubbles.

PASSIVE: The float operated automatic air vent to expel the collected air bubbles.

The use of de-aerators by removing air from the system helps to prevent unnecessary failures by helping to;

- Increase heating and cooling efficiency
- Reduces the formation of corrosion in all parts of the system.
- Reducing the amount of maintenance required
- Reduces the effects causing system noise.
- Lower running costs.



Products

Micro-bubble De-aerator with 3/4" NPT Threaded Connections	ZU0001
Micro-bubble De-aerator with 1" NPT Threaded Connections	ZU0002
Micro-bubble De-aerator with 1 1/4" NPT Threaded Connections	ZU0003
Micro-bubble De-aerator with 3/4" Solder Ends to ANSI B16.22	ZU0004
Micro-bubble De-aerator with 1" Solder Ends to ANSI B16.22	ZU0005
Micro-bubble De-aerator with 1 1/4" Solder Ends to ANSI B16.22	ZU0006

Dimensions

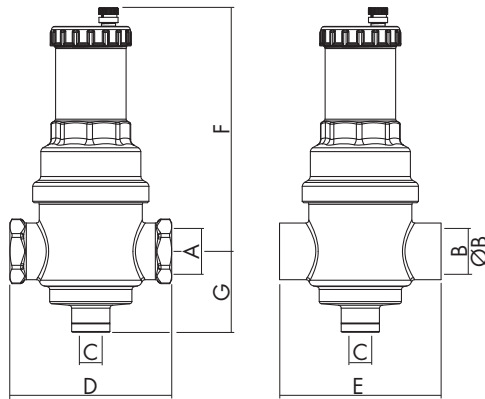

Size	A	B	ØB	C	D	E	F	G
3/4"	3/4"- NPT	3/4"Solder	0.88"	1/2"- NPT	4.33"	4.33"	6.52"	2.16"
1"	1"- NPT	1"Solder	1.33"	1/2"- NPT	4.33"	4.33"	6.52"	2.16"
1 1/4"	1 1/4"- NPT	1 1/4"Solder	1.38"	1/2"- NPT	4.33"	4.33"	6.52"	2.16"

Technical Specification

Fluid:	Water
Maximum glycol percentage:	50%
Maximum temperature:	230°F
Maximum working pressure:	150 psi
Maximum discharge pressure:	150 psi

Flow Data and Cv Values

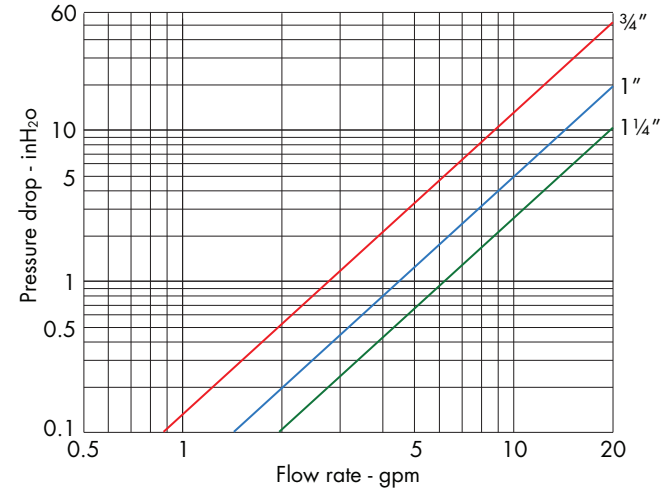

Size	3/4"	1"	1 1/4"
Cv	14.65	23.65	32.56

It is recommended to keep the maximum flow velocity of the fluid in the pipework within 4 ft/s.

Higher flow velocities will reduce the efficiency of the de-aerator and its ability to discharge the collected air.

The table opposite shows the corresponding quantity of fluid in gpm corresponding to 4 ft/s.

Size	gpm
3/4"	6.0
1"	9.3
1 1/4"	15.4

Air Discharge Capacity Diagram

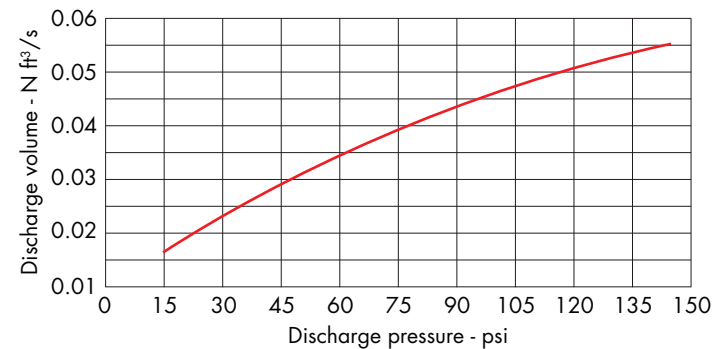

NOTE: N ft³/s is the discharge in ft³/s at atmospheric pressure