

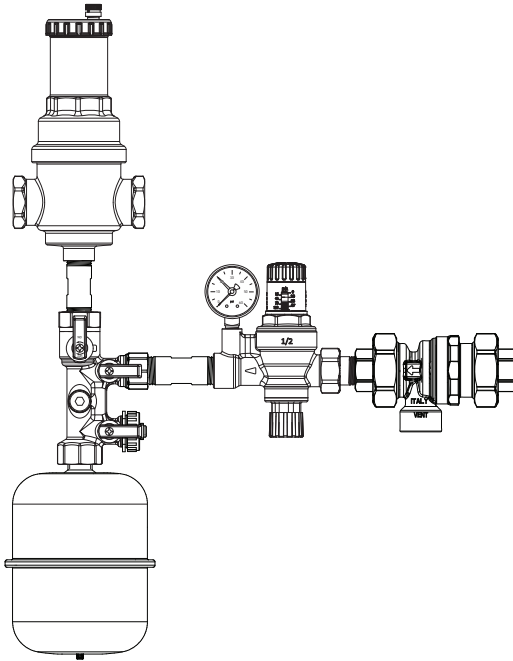

# ZILMET

## Boiler Kit

### Assembly and Installation Instructions



ZILMET USA  
400 FRENCHTOWN ROAD  
EAST GREENWICH  
RI 02818

T. (401) 884 4943  
E. INFO@ZILMETUSA.COM

[WWW.ZILMETUSA.COM](http://WWW.ZILMETUSA.COM)

## Components

The ZILMET boiler kit is supplied as separate components which the installer needs to assemble.

Before commencing check that all the components listed below are present.

If any components are missing please contact ZILMET as soon as possible.

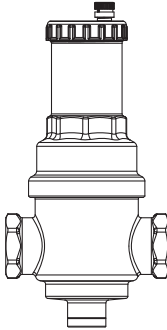

1 x Micro Bubble De-aerator

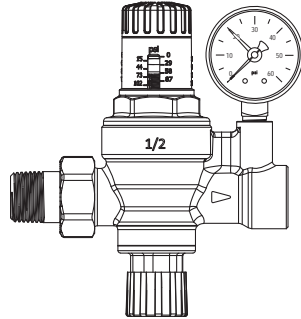

1 x Boiler Fill Valve

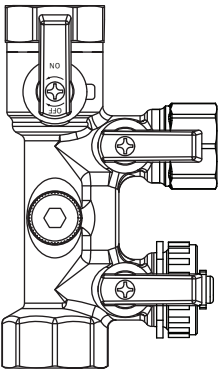

1 x Multi Isolation Valve

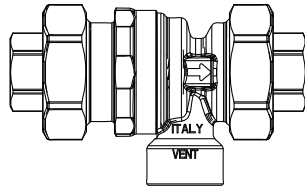

1 x Backflow Preventer



2 x Brass Connector

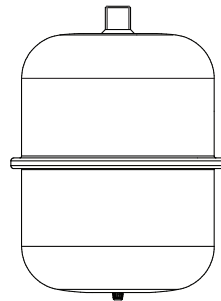

1 x Heating Vessel

## Prior to Assembly

Each component is supplied separately and is supplied with its own installation and maintenance instruction.

Please refer to these instructions if there is any doubt about the suitability of a component for the intended application.

The components should only be unpacked immediately prior to assembly to avoid damage or foreign particles entering through the end ports.

All the components have either male or female threaded connections.

When assembling threaded components, thread sealing liquid or tape should be used on the pipe threads but excessive use should be avoided. The use of hemp-style material should be avoided since this may cause over stressing of the female ends.

## Assembly

The components can be assembled in any order but it is recommended to assemble around the multi isolation valve.

Where components have a hexagonal end or flats these should be used to locate a suitable spanner or wrench and hold the component when assembling the mating item.

### 1 **Micro Bubble De-aerator and Brass Connector**

Remove the plug from the bottom of the micro bubble de-aerator which has a 1/2" thread.

Hold the de-aerator secure and screw the brass connector, using the 2 flats, into the bottom connection.

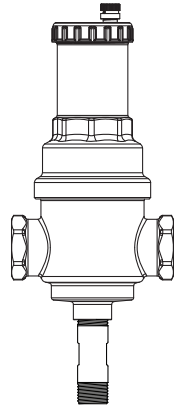

## Assembly

### 2 Backflow Preventer, Boiler Fill Valve and Brass Connector

Unscrew the union tailpiece from the boiler fill valve and screw into the union end of the backflow preventer using the hexagon end to make a water tight joint.

Refit the union tailpiece and back flow preventer to the boiler fill valve by hand tighten.

Check the flow direction arrow on both components are pointing in the same direction.

Hold securely the boiler fill valve by the hexagon end and screw in the brass connector, using the 2 flats.

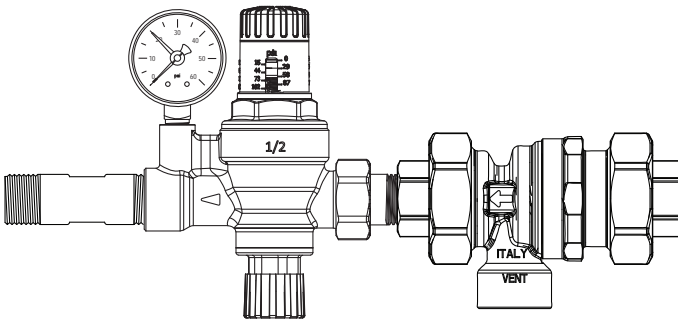

### 3 Assemble to the Multi Isolation Valve

Assemble the de-aerator, brass connector and the backflow preventer, boiler fill valve and brass connector using the hexagon ends on the multi isolation valve and flats on the brass connectors.

Once the joints are tight and the components are all aligned vertically finally tight the union joint on the pressure reducing valve.

Finally screw the heating vessel into the bottom of the multi isolation valve.

See page 4 for assembled components.

The assembly must be adequately supported and not support just by the connecting pipework.

Close all ball valves on the multi isolation valve.

Connect the assembly to the incoming water supply.

Pipe work or a blanking plug should be connected to the de-aerator to allow the assembly to be commissioned.

## 4 Assembled to Components

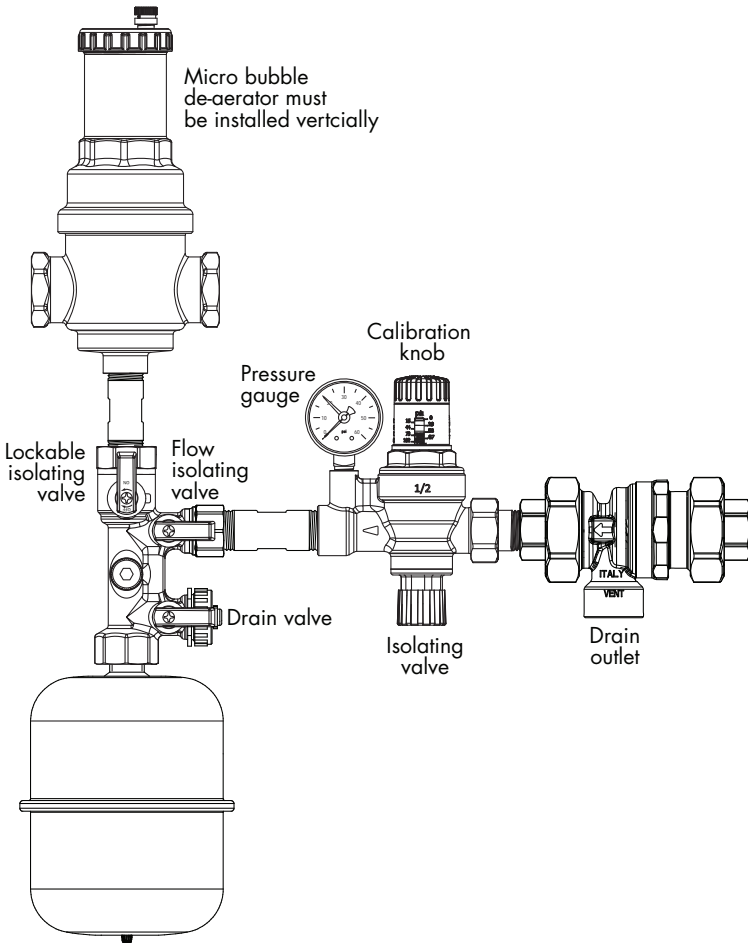

## Filling

Turn on the water supply and check for leaking joints up to the multi isolation valve.

Open the isolating valves on the multi isolation valve and check for leaking joints to the heating vessel and air separator.

## Flushing and Draining

The backflow preventer, boiler fill valve and multi isolation valve can be flushed by the incoming water by closing the lockable isolating valve and opening the drain valve.

Any water flushed through the drain valve must be collected or pipe away to a suitable drain.

The multi isolation valve can also be used to drain part of the system by closing the flow isolating valve and opening the drain valve.

## Calibration of the Boiler Fill Valve



The calibration of the boiler fill valve must be carried out with the system full and all outlets (taps, showers etc.) closed, otherwise values would be affected during possible supply as the downstream pressure decrease in relation to the amount of required flow.

The unit is calibrated by turning the calibration knob clockwise to increase the pressure and anti-clockwise to reduce it.

Open some water outlets (taps) to check the stability of the calibration.

**NOTE:** With the system operational, the pressure indicated on the pressure gauge may increase by the over pressure of the thermal system, a possible correction must be made with all the water outlets closed and at ambient temperature.

## Locking Feature

After the ball valve has been operated to the fully open position, the outlet port can be locked to prevent unauthorised closing of the port.

Remove the lever retaining screw and pull the lever away from the valve, rotate through 180 degrees and refit so that the notch in the lever fits over the lug on the body.

Refit and tighten the lever retaining screw.

**Notes:**



ZILMET USA  
400 FRENCHTOWN ROAD  
EAST GREENWICH  
RI 02818

T. (401) 884 4943  
E. INFO@ZILMETUSA.COM

[WWW.ZILMETUSA.COM](http://WWW.ZILMETUSA.COM)

E & O.E

9-24-2020