

Parts List Number :YHCUP6

Model Number :YHC036E3EMA000

Part No.	Reference No.	Quantity	Description
75008463	3		REFRIGERATION
75006103	4		FAN
75008684	8		MODEL NUMBER DESCRIPTION, DIGITS 1-17
75008685	8		MODEL NUMBER DESCRIPTION, DIGITS 18-31
75008686	8		MODEL NUMBER NOTES
OPTIONS	9		OPTIONAL FIELD INSTALLED ACCESSORIES

Refrigeration

75008463

REV
A

Typical illustration. Unit may not appear exactly as shown.

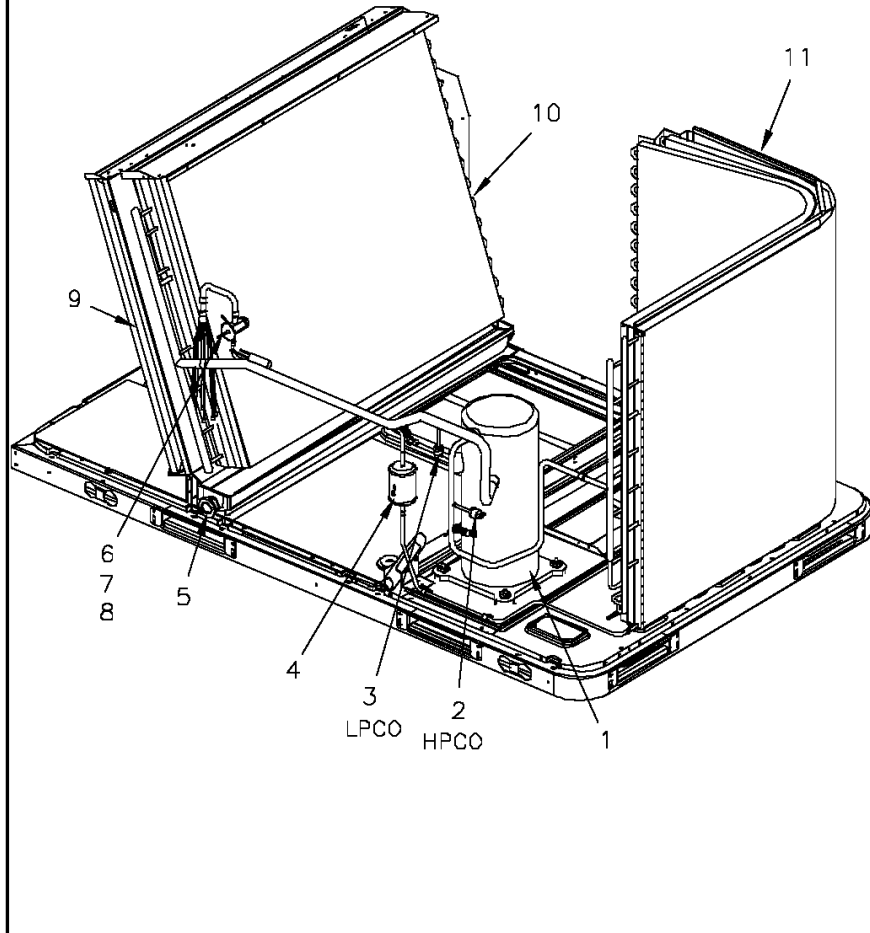

Part No.	Reference No.	Quantity	Description
BRK03027	*	1	BRACKET; FILTER SPACER, 41.00 LG, .50 X .50
BRK03028	*	2	BRACKET; FILTER RETAINER, 38.70 LG, .97 X .97
BRK03029	*	1	BRACKET; FILTER STOP, 29.60 LG, 2.5 X 2.6 X 2.5
BRK03274	*	2	BRACKET; BASE SUPPORT MOUNT, 10.3 LENGTH (FORKLIFT BRACKET)
CNL01178	*	1	CHANNEL; INDOOR COIL SUPPORT, 42 INCH LENGTH
HTR03435	*	1	HEATER; CRANKCASE, 6.5 DIA, 40W, 230V
ISR00007	*	1	ISOLATOR; VIBRATION
KIT08039	*	1	KIT; GROMMETS. COMPRESSOR MOUNTING. (CONSISTS OF 4), 0.44 ID X 1.63 OD NEOPRENE RUBBER-BLACK 45-55 DUROMETER
NUT00355	*	4	NUT; HEX, LOCK, 5/16IN.-18
NUT00890	*	4	NUT; PALLET, 5/16-18 UNC 2B THD.
PLT04187	*	1	PLATE; COMPRESSOR MOUNTING, 17.0 X 11.0
SET00819	*	2	SEAT; SADDLE MOUNT ASSEMBLY
STM00803	*	2	STEM; SADDLE MOUNT, VALVE CORE, BRASS, .344 DIA X 1.29 SCHRAEDER TYPE FITTING (TO INCLUDE 5 PIECES)
WIR03227	*	1	WIRE; PLUG, 30 IN LENGTH, FOR 230/60/3 OR 460/60/3 OR 575/60/3 SCROLL COMPRESSOR (RD,BL,BK WIRES)
WIR04406	*	1	WIRE; HARNESS, LOW PRESSURE SWITCH, 42 IN LENGTH, BLUE WIRES, CIR 1
COM08742	1	1	COMPRESSOR; SCROLL, SPA032B3BPZ, 2.5 TON, 200-230/60/3, R410A, .50 ID DISCHARGE, .75 ID SUCTION
SWT03398	2	1	SWITCH; HIGH PRESSURE, BRAZED, OPENS AT 650 PSIG, CLOSES AT 550 PSIG, 36 INCH WHITE LEADS
SWT03173	3	1	SWITCH; LOW PRESSURE CUTOUT, 250 OPEN, ACTUATION PRESSURE 41 +/- 4, RESET PRESSURE 25 +/- 4
DHY01287	4	1	FILTER DRIER; LIQUID LINE, 5/16 ODM INLET X 5/16 ODF OUTLET
PAN02767	5	1	PAN; DRAIN, 43 INCH LENGTH
TUB12008	6	1	TUBE; ASSEMBLY, INDOOR TXV
VAL08786	7	1	VALVE; TXV, 3 TON, 5/16 ODM X 1/2 ODF, 83 PSIG SH SETPOINT, R410A
TUB11743	8	1	TUBE; ASSEMBLY, INDOOR DISTRIBUTOR, 9 OUTLETS
COL13563	10	1	COIL; INDOOR, FLAT FIN (TXV NOT INCLUDED)

Fan

75006103

REV
A

Typical illustration. Unit may not appear exactly as shown.

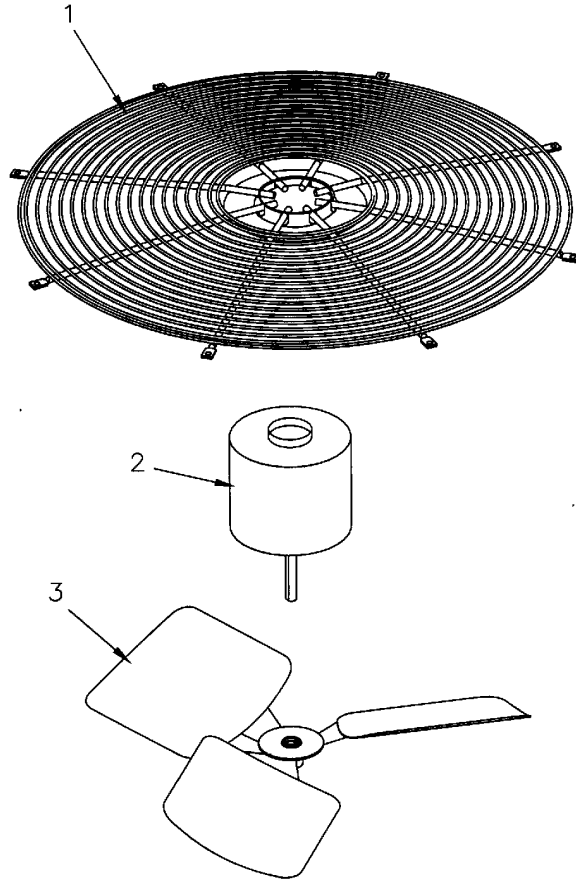

Part No.	Reference No.	Quantity	Description
SCR01996	*	1	SCREW; #10-32 THREAD FORMING, IND 5/16 HEX FLG WASHER HEAD, .438/.408 LENGTH, W/GERNIBS TAPTITE II (4 PER BAG)
GRL01332	1	1	GRILLE; FAN, 26.65 MTG HOLE DIAMETER
MOT10331	2	1	MOTOR; OD FAN, 1/5 HP, 1115 RPM, 208-230/60/1, CCW LEAD END, SLEEVE BEARINGS, 48 FRAME, 3 MFD CPT AT 370V
FAN03042	3	1	FAN; 2 BLADE, 22 IN DIA, 24 DEG PITCH, CCW, 1/2 BORE

Model Number Notes

75008686

REV
D

Packaged Gas/Electric YHC036E,YHC048E/F,YHC060E/F

- ① Microchannel Condensor Coils are standard on THC048F & THC060F models.
- ② Manual outside air damper will ship factory supplied within the unit, but must be field installed.
- ③ Economizer with Barometric Relief is for downflow configured units only. Order Economizer without Barometric Relief for horizontal configuration. Barometric Relief for horizontal configured units must be ordered as field installed accessory.
- ④ Not available with electromechanical controls
- ⑤ Multispeed direct drive is standard on single phase. Belt drive is standard on dehumidification units.
- ⑥ Belt Drive is optional on 3 phase units.
- ⑦ Epoxy coil and epoxy with hailguard options are not available for units with microchannel condenser coil.
- ⑧ Through the base electric required when ordering disconnect/circuit breaker options.
- ⑨ Includes gas piping and shutoff (field assembly required).
- ⑩ Requires use of Disconnect or Circuit Breaker. Powered Convenience Outlet not available on High Efficiency 575V.
- ⑪ Standard metering devices are TXVs.
- ⑫ Dehumidification option not available for standard efficiency models.
- ⑬ Requires selection of 2" Pleated Filters (option B or C) for Digit 16
- ⑭ Crankcase Heater & High Pressure Control are standard on all units.
- ⑮ Froststat cannot be field installed in electromechanical units.
- ⑯ Not available with high temperature duct sensor accessory.
- ⑰ Return Air Smoke Detector cannot be ordered with Novar Controls.
- ⑱ The return air smoke detector may not fit up or work properly on the Precedent units when used in conjunction with 3rd party accessories such as bolt on heat wheels, economizers and power exhaust. Do not order the return air smoke detectors when using this type of accessory.
- ⑲ These options are standard when ordering Novar Controls.
- ⑳ This option is used when ordering Novar Controls.
- ㉑ Novar Sensor utilized with Digit 21=(4) Novar 3051 Controls without Zone Sensor.
- ㉒ Demand Control Ventilation Option includes wiring only. The CO sensor is a field-installed only option.
- ㉓ Demand Control Ventilation Option not available with electromechanical controls.

Model Number Description	75008685	REV D
Packaged Gas/Electric YHC036E,YHC048E/F,YHC060E/F Digits 18 through 27		
<p>DIGIT 18 – Through the Base Provisions</p> <p>0 = No Through the Base Provisions</p> <p>A = Through the Base Electric (8)</p> <p>B = Through the Base Gas Piping</p> <p>A = Through the Base Electric and Disconnect (9)</p> <p>DIGIT 19 – Disconnect/Circuit Breaker</p> <p>0 = No Disconnect/No Circuit Breaker</p> <p>1 = Unit Mounted Non–Fused Disconnect (8)</p> <p>2 = Unit Mounted Circuit Breaker (8)</p> <p>DIGIT 20 = Convenience Outlet</p> <p>0 = No Convenience Outlet</p> <p>A = Unpowered Convenience Outlet</p> <p>B = Powered Convenience Outlet (10)</p> <p>DIGIT 21 – Communications Options (4)</p> <p>0 = No Communications Interface</p> <p>1 = Trane Communications Interface</p> <p>2 = LonTalk® Communications Interface</p> <p>3 = Novar 2024 Controls</p> <p>4 = Novar 3051 Controls without Zone Sensor</p> <p>5 = Novar 3051 Controls Interface with DCV</p> <p>6 = BACnet® Communications Interface</p> <p>7 = Air–Fi™ Wireless Communications</p> <p>DIGIT 22 – Refrigeration System Option</p> <p>0 = Standard Refrigeration System (11)</p> <p>B = Dehumidification Option (12) (13)</p> <p>DIGIT 23 – Refrigeration Controls</p> <p>0 = No Refrigeration Control (14)</p> <p>1 = Frostat (15)</p> <p>DIGIT 24 – Smoke Detector (16)</p> <p>0 = No Smoke Detector</p> <p>A = Return Air Smoke Detector (17) (18)</p> <p>B = Supply Air Smoke Detector</p> <p>C = Supply and Return Air Smoke Detectors (17) (18)</p> <p>D = Plenum Smoke Detector</p>	<p>DIGIT 25 – Monitoring Controls</p> <p>0 = No Monitoring Controls (19)</p> <p>1 = Clogged Filter Switch (19)</p> <p>2 = Fan Failure Switch (19)</p> <p>3 = Discharge Air Sensing Tube (19)</p> <p>4 = Clogged Filter Switch and Fan Failure Switch (19)</p> <p>5 = Clogged Filter Switch and Discharge Air Sensing Tube (19)</p> <p>6 = Fan Failure Switch and Discharge Air Sensing Tube (19)</p> <p>7 = Clogged Filter, Fan Fail Switch and Discharge Air Sensing Tube (19)</p> <p>8 = Novar 2024 Return Air Sensor (20)</p> <p>9 = Novar 3051 Zone Sensor (21)</p> <p>A = Condensate Drain Pan Overflow Switch</p> <p>B = Clogged Filter Switch (19) and Condensate Drain Pan Overflow Switch</p> <p>C = Fan Failure Switch (19) and Condensate Drain Pan Overflow Switch</p> <p>D = Discharge Air Sensing (19) and Condensate Drain Pan Overflow Switch</p> <p>E = Clogged Filter Switch (19), Fan Failure Switch (19) and Condensate Drain Pan Overflow Switch</p> <p>F = Clogged Filter Switch (19), Discharge Air Sensing Tube (19), and Condensate Drain Pan Overflow Switch</p> <p>G = Fan Failure Switch (19), Discharge Air Sensing Tube (19), and Condensate Drain Pan Overflow Switch</p> <p>H = Clogged Filter Switch (19), Fan Failure Switch (19) Discharge Air Sensing Tube (19) and Condensate Drain Pan Overflow Switch</p> <p>DIGIT 26 – System Monitoring Controls</p> <p>0 = No Monitoring Controls</p> <p>1 = Demand Control Ventilation (CO₂) (22) (23)</p> <p>DIGIT 27 – Unit Hardware Enhancements</p> <p>0 = No Enhancements</p> <p>1 = Stainless Steel Drain Pan</p>	
See <u>Model Number Notes</u> graphic for explanation of Notes (1) to (23)		

Model Number Description 75008684		REV D
Packaged Gas/Electric YHC036E,YHC048E/F,YHC060E/F Digits 1 through 17		
<p>DIGIT 1 – Unit Function Y = DX Cooling, Gas Heat</p> <p>DIGIT 2 – Efficiency H = High Efficiency</p> <p>DIGIT 3 – Airflow C = Convertible</p> <p>DIGIT 4,5,6 – Nominal Gross Cooling Capacity (MBh) 036 = 3 Ton 048 = 4 Ton 060 = 6 Ton</p> <p>DIGIT 7 – Major Design Sequence E = R-410A Refrigerant F = Microchannel Type Condenser Coils ①</p> <p>DIGIT 8 – Voltage Selection 1 = 208–230/60/1 3 = 208–230/60/3 4 = 460/60/3 W = 575/60/3</p> <p>DIGIT 9 – Unit Controls E = Electromechanical R = ReliaTel™ Micro-processor</p> <p>DIGITS 10 – Heating Capacity L = Low Heat M = Medium Heat H = High Heat X = Low Heat, Stainless Steel Heat Exchanger Y = Medium Heat, Stainless Steel Heat Exchanger Z = High Heat, Stainless Steel Heat Exchanger</p> <p>DIGIT 11 = Minor Design Sequence A = First Sequence</p> <p>DIGITS 12,13 – Service Sequence ** = Factory Assigned</p>	<p>DIGITS 14 – Fresh Air Selection 0 = No Fresh Air A = Manual Outside Air Damper 0–50% ② B = Motorized Outside Air Damper 0–50% C = Economizer, Dry Bulb 0–100% without Barometric Relief ③ D = Economizer, Dry Bulb 0–100% with Barometric Relief ③ E = Economizer, Reference Enthalpy 0–100% without Barometric Relief ③ ④ F = Economizer, Reference Enthalpy 0–100% with Barometric Relief ③ ④ G = Economizer, Comparative Enthalpy 0–100% without Barometric Relief ③ ④ H = Economizer, Comparative Enthalpy 0–100% with Barometric Relief ③ ④ K = Low Leak Economizer with Barometric Relief M = Low Leak Economizer with Reference Enthalpy with Barometric Relief P = Low Leak Economizer with Comparative Enthalpy with Barometric Relief</p> <p>DIGIT 15 – Supply Fan/Drive Type/Motor 0 = Standard Drive ⑤ 2 = Optional Belt Drive Motor ⑥</p> <p>DIGIT 16 – Hinged Service Access/Filters 0 = Standard Panels/Standard Filters A = Hinged Access Panels/Standard Filters B = Standard Panels/2" MERV 8 Filters C = Hinged Access Panels/2" MERV 8 Filters D = Standard Panels/2" MERV 13 Filters E = Hinged Access Panels/2" MERV 13 Filters</p> <p>DIGIT 17 – Condenser Coil Protection 0 = Standard Coil 1 = Standard Coil with Hail Guard 2 = Black Epoxy Pre-Coated Condenser Coil ⑦ 3 = Black Epoxy Pre-Coated Condenser Coil with Hail Guard ⑦ 4 = CompleteCoat™ Condenser Coil 5 = CompleteCoat™ Condenser Coil with Hail Guard</p>	
See <u>Model Number Notes</u> graphic for explanation of Notes ① to ②③		

Parts List Number :YHCUP6

Model Number :YHC036E3EMA000

Part No.	Reference No.	Quantity	Description
BAS01908	*	1	BASE; THERMOSTAT, 18-32V, 50/60 HZ, GAS AND ELECTRIC, 2 STAGE HEAT AND 2 STAGE COOLING (BAYBASE006AA)
BAS01910	*	1	BASE; THERMOSTAT 18-32V, 50/60HZ, GAS AND ELECTRIC, 1 STAGE HEAT AND 1 STAGE COOLING (BAYBASE008AA)
BAYPWRX070A	*	1	POWER EXHAUST, 230V, FOR 3-5 TON T/W/YSC, D/T/W/YHC, T/YZC
DMP02175	*	1	DAMPER; 0-50% MANUAL OUTSIDE AIR DAMPER (BAYDMPR053BA)
DMP02842	*	1	DAMPER; 0-50% MOTORIZED OUTSIDE AIR DAMPER, ELECTROMECHANICAL (BAYDMPR052A)
ECN00107	*	1	ECONOMIZER; ELECTROMECHANICAL, 0-100% DRY BULB (BAYECON086A)
GRD01610	*	1	GUARD; HAIL GUARD ACCESSORY (BAYGARD037BB)
KIT06658	*	1	KIT; ENTHALPY CONTROL (BAYENTH001AB)
KIT13706	*	1	KIT; HIGH ALTITUDE (BAYHAKT010BB)
KIT15033	*	1	KIT; LP CONVERSION (BAYLPKT050AA)
KIT15389	*	1	KIT; FLUE EXTENSION - 5 FT LENGTH, 7 INCH EXTENSION, 4 IN SQUARE. INCLUDES SCREEN, BRACKET AND 8 SCREWS
SEN01127	*	1	SENSOR; REMOTE WALL (BAYSENS033AA)
SEN01128	*	1	SENSOR; TEMPERATURE (BAYSENS034AA), RETURN AIR REMOTE TEMPERATURE SENSOR
SEN01195	*	1	SENSOR; HUMIDITY ZONE, WALL MOUNTED, TRANE (BAYSENS036A)
SEN01196	*	1	SENSOR; HUMIDITY ZONE, DUCT MOUNTED, TRANE (BAYSENS037A)
THT02120	*	1	THERMOSTAT; 1 HEAT(GAS)/1 COOL, NON PROGRAMMABLE (TAYSTAT370), CONTAINS NO MERCURY
THT02122	*	1	THERMOSTAT; 2 HEAT (ELECTRIC/GAS) 1 COOL ELECTRONIC NON PROGRAMMABLE (TAYSTAT380), CONTAINS NO MERCURY
THT02424	*	1	THERMOSTAT; 1 HEAT (GAS/ELEC) 1 COOL (TCONT200ANN11AAA) NON-PROGRAMMABLE.
TMR00140	*	1	TIMER; ANTISHORT CYCLE (BAYASCT001)