



**DEPENDABLE.
ECONOMICAL.
UNBEATABLE.**

SWIMMING POOL HEAT EXCHANGERS



Our Swimming Pool Heat Exchangers are designed with you mind:

- Perfect for swimming pools, spas and hot tubs
- Corrosion-resistant, 316 stainless steel construction
- Specially designed built-in flow restrictor assures maximum heat transfer
- Furnished with stainless steel holding brackets
- Compact size, lightweight, with low pressure drop
- Backed by Weil-McLain's quality and sales support

The size you need, the performance you demand

Weil-McLain model WMPH pool heaters are available in five sizes from 95 to 400 MBH output. Designed for use with Weil-McLain boilers, these heat exchangers provide dependable, economical heating for all types and sizes of swimming pools, spas and hot tubs.



Better value and support

Backed by Weil-McLain for the best value in product quality, service and technical support.

Key Benefits:

- Made of high quality, corrosion-resistant 316 stainless steel, roll-formed and precision-welded
- Specially designed built-in flow restrictor assures maximum heat transfer
- Compact size, lightweight with low pressure drop
- All units are leak tested to ensure the highest quality
- Furnished with stainless steel holding brackets

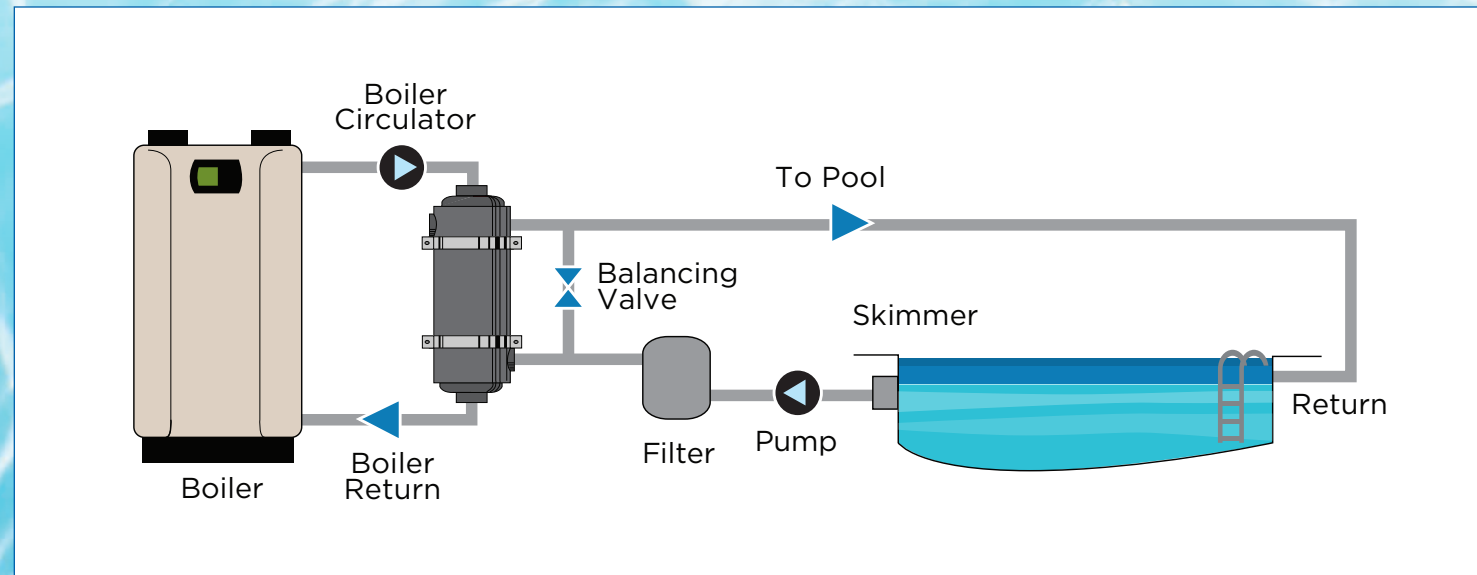

Heat Exchanger Selection: A 4-step process

STEP 1:

Determine the desired heat-up rate based on pool usage.

- The heat-up rate for extended use (summer season) is 1°F/hr. The heat-up rate for periodic use (weekends and holidays) is 2°F/hr.

STEP 2:

Determine pool capacity.

- Rectangular Pool Capacity = 7.5 x Length (ft) x Width (ft) x Average Depth (ft).
- Circular Pool Capacity = 5.9 x Diameter² (ft) x Average Depth (ft).

STEP 3:

Select heat exchanger required.

- Using the table below, determine the recommended heat exchanger based on your pool capacity and desired heat up rate.

STEP 4:

Check heat loss to surroundings.

- Heat Loss = 12 x (pool surface area in sq. ft) x (desired pool temp) - (coldest average air temp during use).
- Boiler output selected in Step 3 must be more than the heat loss to surroundings.

Pool Capacity (gal.)	1°F/hr. Heat-Up Rate		2°/hr. Heat-Up Rate	
	Boiler Output Required (BTU/hr)	Heat Exchanger Model	Boiler Output Required (BTU/hr)	Heat Exchanger Model
2,000	17,000	WMPH-95	33,000	WMPH-95
4,000	33,000	WMPH-95	67,000	WMPH-95
6,000	50,000	WMPH-95	100,000	WMPH-135
8,000	67,000	WMPH-95	133,000	WMPH-135
10,000	83,000	WMPH-135	167,000	WMPH-200
12,000	100,000	WMPH-135	200,000	WMPH-260
14,000	117,000	WMPH-135	234,000	WMPH-260
16,000	133,000	WMPH-135	267,000	WMPH-400
18,000	150,000	WMPH-200	300,000	WMPH-400
20,000	167,000	WMPH-200	334,000	WMPH-400
22,000	184,000	WMPH-200	367,000	WMPH-400
24,000	200,000	WMPH-260	400,000	WMPH-400
26,000	217,000	WMPH-260	434,000	WMPH-260 (2)*
28,000	234,000	WMPH-260	467,000	WMPH-260 (2)*
30,000	250,000	WMPH-260	500,000	WMPH-260 (2)*
32,000	267,000	WMPH-400	534,000	WMPH-400 (2)*
34,000	284,000	WMPH-400	567,000	WMPH-400 (2)*
36,000	300,000	WMPH-400	600,000	WMPH-400 (2)*
38,000	317,000	WMPH-400	634,000	WMPH-400 (2)*
40,000	334,000	WMPH-400	667,000	WMPH-400 (2)*
42,000	350,000	WMPH-400	700,000	WMPH-400 (2)*
44,000	367,000	WMPH-400	734,000	WMPH-400 (2)*
46,000	384,000	WMPH-400	767,000	WMPH-400 (2)*

Note:

- The typical desired pool temperature is 80°F.
- Heat-up rates will decrease as outdoor temperature drops.
- Use WMPH - 95 for spas and hot tubs with 150 gallons or less capacity.

*Two heat exchangers piped reverse return.

Optimizing Heat Exchanger Performance

Swimming Pool Heat Exchanger Ratings

Model No.	Output BTU/Hr.	Boiler Water Flow		Pool Water Flow		Heat Transfer Surface Sq. Ft.	Approx. Shipping Weight - Lbs.
		GPM	Pressure Drop Ft.	GPM	Pressure Drop Ft.		
WMPH - 95	95,000	6.0	3.8	40	0.3	2.0	6
WMPH - 135	135,000	6.6	1.0	55	2.7	3.2	8
WMPH - 200	200,000	8.0	1.7	65	4.5	4.8	11
WMPH - 260	260,000	9.4	2.3	80	6.0	6.4	14
WMPH - 400	400,000	13.0	6.0	95	8.0	11.8	24

Ratings are based on 110°F temperature difference between boiler water and pool water.
Boiler side: Maximum working pressure = 140 psi; Maximum working temperature = 230°F

Dimensions

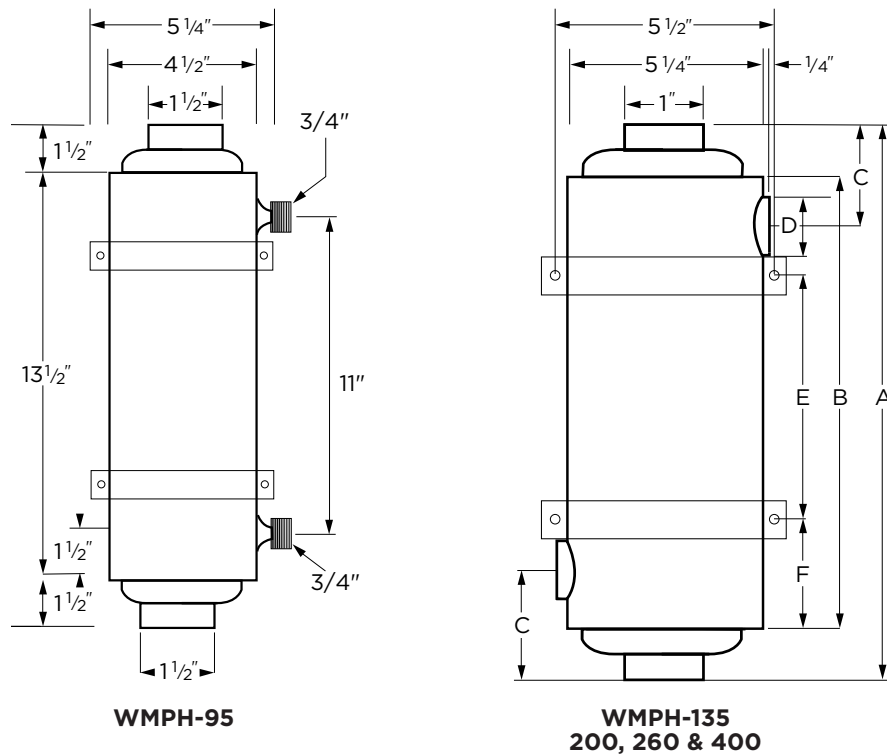

Model No.	A	B	C	D	E	F
WMPH - 135	13 1/2"	11"	3"	1 1/2"	4"	3 1/2"
WMPH - 200	18 3/4"	16"	3"	1 1/2"	9"	3 1/2"
WMPH - 260	23 3/4"	21 1/4"	3"	1 1/2"	14"	3 1/2"
WMPH - 400	41 3/4"	39 3/8"	3 1/2"	2"	31 1/2"	4"