



Evergreen[®]

CONDENSING GAS BOILER
220/299/300/399

Direct Exhaust Venting Kit Instructions

Evergreen[®] 220/299/300/399 — Kit part number 383-500-769

STOP! Read before proceeding

Hazard definitions

The following defined terms are used throughout this instruction to bring attention to the presence of hazards of various risk levels or to important information concerning the life of the product.

▲ DANGER Indicates presence of hazards that will cause severe personal injury, death or substantial property damage.

▲ WARNING Indicates presence of hazards that can cause severe personal injury, death or substantial property damage.

▲ CAUTION Indicates presence of hazards that will or can cause minor personal injury or property damage.

NOTICE Indicates special instructions on installation, operation or maintenance that are important but not related to personal injury or property damage.

▲ WARNING **These instructions must only be used by a qualified installer/service technician.** Read all instructions completely before beginning the installation. Failure to follow all instructions can cause severe personal injury, death or substantial property damage.

▲ WARNING The boiler contains ceramic fiber and fiberglass materials. Use care when handling these materials per instructions in the Boiler Manual, available on-line at Weil-McLain.com. Failure to comply could result in severe personal injury.

▲ WARNING You must read and have the Evergreen[®] boiler manual with you to proceed with these instructions.

Follow all instructions in this instruction and the Evergreen[®] boiler manual to access and service components. The parts provided in this kit are required to complete the setup for Direct Exhaust Venting.

The boiler manuals are available on-line at Weil-McLain.com





Evergreen® Direct Exhaust Vent Kit P/N 383-500-769 contents:

Item	Description	Part No.	Qty
1	Plate Intake/Exhaust Air Interior	460-000-000	1
2	Plate Intake/Exhaust Air Exterior	460-000-001	1
3	Vent Screen 3 In Mesh 304 Stainless Steel	560-907-632	1
4	Vent Screen 4 In Mesh 304 Stainless Steel	560-907-631	2
5	Template Vent/Air Termination Hole	550-100-025	1
6	Anchor Plastic for 310 Screw	563-210-627	8
7	Screw SM Type AB Pan Head Phillips 10 x 1-1/4 ZP	592-100-002	8
8	Instructions Direct Exhaust Venting EVG	550-100-156	1

Recommended tools

See Evergreen® boiler manual for details.

Installation instructions

Installer



Read all instructions before installing. Follow all instructions in proper order to prevent personal injury or death.

NOTICE

Inlet and outlet pipe and fittings provided by installer.

1. Install 4” diameter PVC or CPVC pipe and elbow on air inlet of boiler.
2. Install 4” screen in opening of elbow.

NOTICE

Installation of pipe and elbow in inlet is to prevent objects from inadvertently entering or blocking air inlet.

3. Use the template to cut appropriate hole in wall for exhaust. Use only the exhaust hole!
4. Run the exhaust vent piping to the wall in accordance with the instructions shown on the following pages.
5. Install appropriate size bird screen in end termination.

Perform Boiler Manual start-up



Follow all instructions in boiler manual to start-up the boiler after converting to Direct Exhaust. Because the boiler has been changed, you must verify correct operation, including checking combustion with test instruments both at high fire and low fire as described in the Boiler Manual. Failure to comply could result in severe personal injury, death or substantial property damage.



Venting & air — general

Figure 1 Evergreen® venting — DIRECT EXHAUST ONLY — OPTIONS and PIPING LIMITS

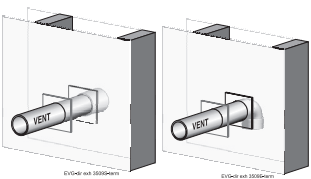
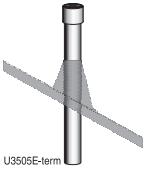

NOTICE The table below lists the acceptable vent pipe terminations described in this instruction. Follow all instructions provided to install the vent system. **NOT SHOWN** below, but also approved, are the polypropylene piping and terminations listed in Figure 2, page 4. For these applications, use **ONLY** the manufacturers' parts listed and follow all instructions provided by the pipe manufacturer.

Evergreen Model	Maximum vent length = 100 feet for all applications				USE SWEEP ELBOWS ONLY
	(Minimum length for all applications is 2 feet equivalent plus termination)				
	(All applications include allowance for the termination fittings plus one elbow in vent piping).				
	See Figure 2, page 4 for material specifications				
	Vent sizes:				
	Maximum vent lengths apply for either 3" or 4" vent and air pipe. If using 3" pipe, provide 4"x 3" tapered reducers at boiler connections and at Weil-McLain vent/air cap termination. Boilers will derate as vent length increases — see rating data on Figure 123, page 129 in the boiler manual for derate amounts.				
	SIDEWALL termination [Note 1 & 2]		VERTICAL termination		
					
	See pages 8 & 9		See page 10		
	Size, inches	Materials page 4	Size, inches	Materials page 4	
220	3	PVC/PVC-DWV CPVC, PP, SS	3	PVC/PVC-DWV CPVC, PP, SS	
	4	PVC/PVC-DWV CPVC, PP, SS	4	PVC/PVC-DWV CPVC, PP, SS	
299/300	4	PVC/PVC-DWV CPVC, PP, SS	4	PVC/PVC-DWV CPVC, PP, SS	
399	4	PVC/PVC-DWV CPVC, PP, SS	4	PVC/PVC-DWV CPVC, PP, SS	
⚠ WARNING All elbows in vent and air piping must be sweep elbows ONLY. DO NOT use short-radius elbows. When transitioning to 4-inch to 3-inch, use tapered reducer with 4" PVC nipple (I ≥ 6"). Do not use 4-inch to 3-inch bushing. Bushing will Not seal in boiler adapter.					
Equivalent feet for elbows (USE SWEEP ELBOWS ONLY) — deduct from max equivalent length of piping (does not apply to termination fittings) • 7 feet per for each additional 90° sweep elbow or 45° elbow for PVC only; for PP please see manufacturers recommendations. — If piping contains more than 1 elbow in vent piping, other than termination fittings.					
Note 1	Material abbreviations: PP = polypropylene, SS = AL29-4C stainless steel If using polypropylene or stainless pipe, provide adapters for 4" boiler connections and for terminations. For ULC S636 compliance, all pipe, fittings and cement must be IPEX System 636. If using IPEX kits, use only IPEX product code listed in Figure 111, page 117 in the boiler manual. Contact Weil-McLain for ordering information and availability of Weil-McLain venting kits.				
Note 2	Use only Weil-McLain approved termination kits listed in Figure 111, page 117 in the boiler manual.				

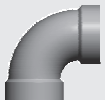

Venting & air — general *(continued)*

Figure 2 Vent and air piping materials — Use only the materials listed below, ensuring that all materials meet local codes (see Figure 111, page 117 in the boiler manual for part/kit numbers)

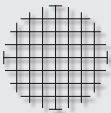
Item	Material	Standards for installations in:		
		United States	Canada	
Plastic piping materials		Vent or air piping	Vent piping	Air piping
Vent or air pipe & fittings	PVC schedule 40 (Note 1)	ANSI/ASTM D1785	ULC S636	PVC, PVC-DWV, CPVC or polypropylene
	PVC-DWV schedule 40 (Note 1)	ANSI/ASTM D2665	N/A	
	CPVC schedule 40 (Note 1)	ANSI/ASTM F441	ULC S636	
PVC & ABS pipe cement & primer	PVC (Note 1)	ANSI/ASTM D2564/F656	ULC S636	Use only cement and primer suitable for piping material used
	CPVC (Note 1)	ANSI/ASTM F493	ULC S636	
	CPVC to PVC transition	Use only cement and primer suitable for piping material used	ULC S636	
Polypropylene vent pipe, fittings, terminations and cement	Simpson-Duravent — Obtain all materials from M&G Simpson-Duravent Centrotherm Eco Systems InnoFlue® Single-wall — Obtain all materials from Centrotherm (Note: See page 117 in the boiler manual for correct appliance adapters to be used.)	See manufacturer's literature for detailed information MUST USE LOCKING COLLAR ON EVERY JOINT	ULC S636	PVC, PVC-DWV, CPVC or polypropylene
AL29-4C stainless steel piping materials				
Vent pipe AL29-4C stainless steel	Heat Fab, Inc. — Saf-T-Vent® Z-Flex, Inc. — Z-Vent Dura-Vent — FasNSeal™ Metal-Fab, Inc. — CORR/GUARD	Certified for Category IV and direct exhaust appliance venting	Certified for Category IV and direct exhaust appliance venting	
Weil-McLain stainless steel bird screens, 3" or 4" (Included in kit) - see Figure 111, page 117 in boiler manual for part numbers				
Note 1:	System 636 PVC concentric terminations utilize PVC pipe/fittings certified to ULC S636. If ULC S636 compliance is required, use only System 636 pipe, fittings and cement.	⚠ WARNING ADAPTERS — AL29-4C piping — Install a PVC-to-stainless adapter supplied by the AL29-4C stainless pipe manufacturer at the 4" PVC boiler vent connection and at the termination (if using Weil-McLain plate termination). ADAPTERS — Polypropylene piping — Provide adapters from polypropylene pipe to the 4" PVC connections at the boiler and at terminations, if required (Weil-McLain sidewall plate, for example). ADAPTERS — If using 3" piping, where approved for the application, provide adapters for the 4" PVC boiler connections and at the terminations, if required (Weil-McLain sidewall plate, for example).		
⚠ WARNING	DO NOT mix piping from different pipe manufacturers unless using adapters specifically designed for the purpose by the manufacturer.			
⚠ WARNING	Every joint on polypropylene vent piping must include a locking collar.			
⚠ WARNING	DO NOT use cellular core PVC (ASTM F891), cellular core CPVC, or Radel® (polyphenolsulfone) in venting systems.			
⚠ WARNING	DO NOT cover non-metallic vent pipe and fittings with thermal insulation.			
		⚠ WARNING	USE SWEEP ELBOWS FOR ALL VENTING — DO NOT use short radius elbows for vent. Boiler performance could be affected.	
	⚠ WARNING	ALL vent and air pipes require a BIRD SCREEN at each termination. This kit includes the bird screens. [No additional screening is required.]		



Vent termination requirements

Figure 3 The vent termination must be located to meet all requirements below (also applies to vertical vent terminations). The minimum distance from adjacent public walkways, adjacent buildings, openable windows and building in the National Fuel Gas Code, ANSI Z223.1/NFPA 54 - latest edition and/or the Natural Gas and Propane Installation Code, CAN/CSA B149.1. The vent termination clearances below are for U.S.A., for Canadian vent termination clearances please refer to the requirements of CAN/CSA B149.1 Natural Gas and Propane Installation Code. Consideration should be given to avoid possible damage caused by vent plumes and condensate when choosing a venting configuration and location. Maintain a minimum clearance of 4 ft. (1.22m) horizontally from, and in no case above or below, unless a 4 ft. (1.22m) horizontal distance is maintained, from electrical meters, gas meters, regulators, and relief equipment.



MINIMUM CLEARANCES

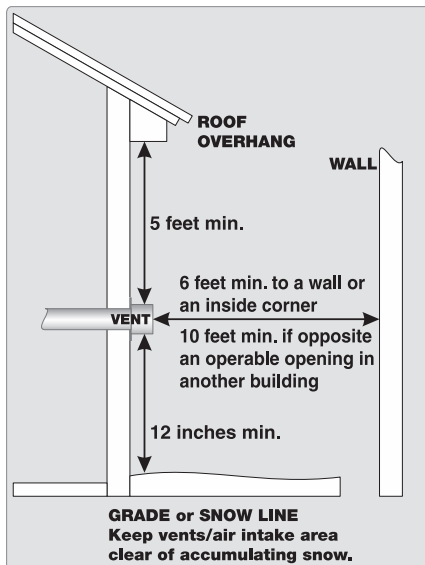
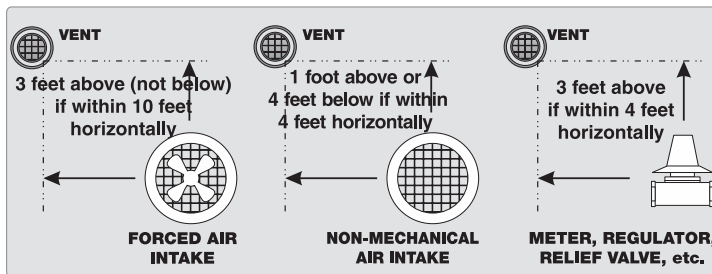
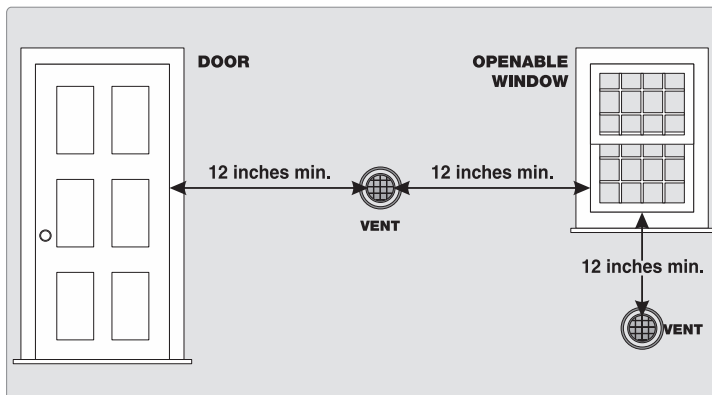

DO NOT TERMINATE:

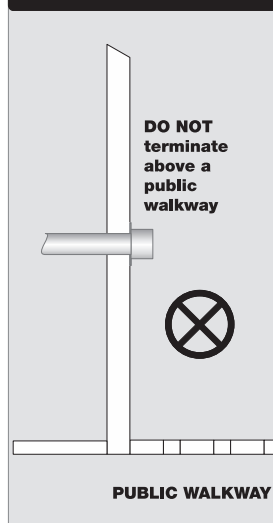

DO NOT TERMINATE:

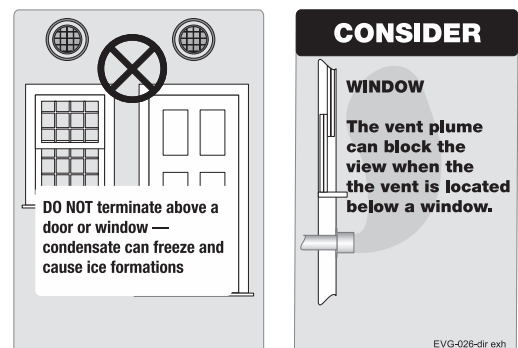
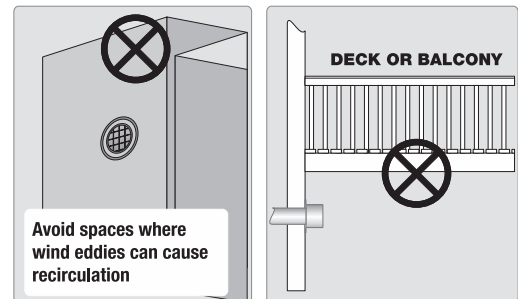
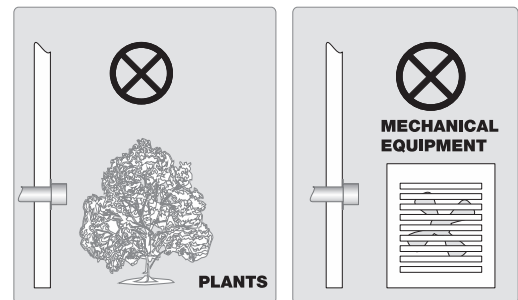



DIRECT EXHAUST — Boiler room air openings

Combustion air provision

The Evergreen® boiler can use inside air if no contaminants are present in the boiler space. (If contaminants are likely to be present, install the boiler as a direct vent appliance, using the appropriate vent instructions in the boiler manual.)

The boiler room must be fitted with combustion air openings large enough to provide air for all appliances in the room. Use the following information to size the openings. Ensure the installation complies with all applicable codes and standards.

Sizing combustion air openings

Air openings provide for ventilation (as well as combustion air) to prevent overheating of the boiler controls and boiler space. Air is also needed for other appliances located in the same space.

Use Figure 4, page 7, selecting the appropriate installation conditions.

▲WARNING Air openings must be sized to handle all appliances and air movers (exhaust fans, etc.) using the air supply.

The sizing given in Figure 4, page 7 is based on the National Fuel Gas Code, ANSI Z223.1/NFPA 54 - latest edition, allowing adequate air openings for gravity-vented gas appliances (Category I) in addition to that needed for the Evergreen® boiler.

The air openings recommended in Figure 4, page 7 will allow adequate ventilation and combustion air provided the boiler room is not subjected to negative pressure due to exhaust fans or other mechanical ventilation devices.

Refer to the National Fuel Gas Code for dealing with other conditions.

Free area — louver allowance

The free area of openings means the area **after reduction for any installed louvers or grilles**. Be sure to consider this reduction when sizing the air openings.

Special considerations

Tight construction

ANSI Z223.1/NFPA 54 - latest edition, defines unusually tight construction where:

1. Walls and ceilings exposed to the outside atmosphere have a continuous water vapor retarder with a rating of 1 perm or less with openings gasketed, and . . .
2. Weather-stripping has been added on openable windows and doors, and . . .
3. Caulking or sealants are applied to areas such as joints around windows and door frames, between sole plates and floors, between wall-ceiling joints, between wall panels, at penetrations for plumbing, electrical, and gas lines, and in other openings.

For buildings with such construction, provide air openings into the building from outside, sized per the appropriate case in Figure 4, page 7 if appliances are to use inside air for combustion and ventilation.

Exhaust fans and air movers

The appliance space must never be under a negative pressure unless all appliances are installed as direct vent. Always provide air openings sized not only to the dimensions required for the firing rate of all appliances, but also to handle the air movement rate of the exhaust fans or air movers using air from the building or space.

Motorized air dampers

If the air openings are fitted with motorized dampers, electrically interlock the damper to:

- Prevent the boiler from firing if the damper is not fully open.
- Shut the boiler down should the damper close during boiler operation.

To accomplish this interlock, wire an **isolated contact** (proving the damper open) in series with the thermostat input to the boiler. The boiler will not start if this contact is open, and will shut down should it open during operation.



DIRECT EXHAUST — Boiler room air openings *(continued)*

Figure 4 Combustion and ventilation air openings for Evergreen® for Direct Exhaust installations. Provisions for combustion and ventilation air to be in accordance with the section “Air for Combustion and Ventilation,” of the National Fuel Gas Code, ANSI Z223.1/NFPA 54 - latest edition, or applicable provisions of the local building codes.

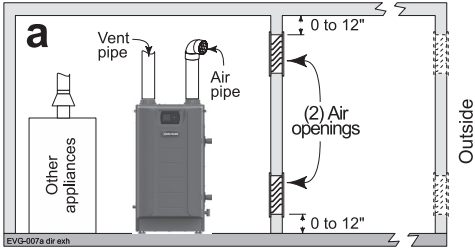
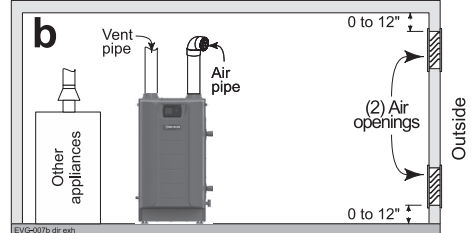
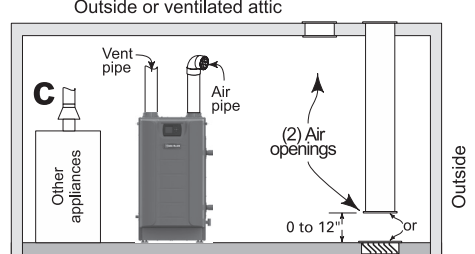
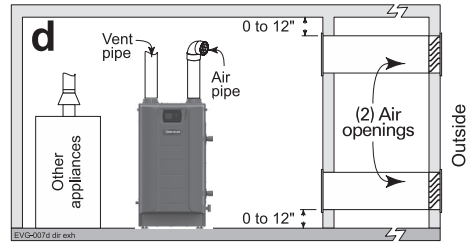
<p style="text-align: center;">Air openings</p> <p>The required air opening sizes below are FREE AREA, after reduction for louver obstruction. Note the exception below for large spaces.</p>	<p style="text-align: center;">Evergreen® boiler WITH other appliances in room</p>	<p style="text-align: center;">Evergreen® boiler WITHOUT other appliances in room</p>
 <p>a</p> <p>Other appliances, Vent pipe, Air pipe, (2) Air openings, 0 to 12", Outside</p> <p><small>EVG-007a dir exh</small></p>	<p>TWO openings, each at least: 1 square inch per 1,000 Btuh of all appliances in the room</p>	<p>TWO openings, each at least: 1 square inch per 4,000 Btuh of all appliances in the room</p>
 <p>b</p> <p>Other appliances, Vent pipe, Air pipe, (2) Air openings, 0 to 12", Outside</p> <p><small>EVG-007b dir exh</small></p>	<p>TWO openings, each at least: 1 square inch per 4,000 Btuh of all appliances in the room — OR — ONE opening **, each at least: 1 square inch per 3,000 Btuh of all appliances in the room</p>	<p>TWO openings, each at least: 1 square inch per 4,000 Btuh of all appliances in the room — OR — ONE opening **, each at least: 1 square inch per 3,000 Btuh of all appliances in the room</p>
 <p>c</p> <p>Other appliances, Vent pipe, Air pipe, (2) Air openings, 0 to 12", Outside or ventilated attic, Outside</p> <p><small>EVG-007c dir exh</small></p>	<p>TWO openings, each at least: 1 square inch per 2,000 Btuh of all appliances in the room — OR — ONE opening **, each at least: 1 square inch per 3,000 Btuh of all appliances in the room</p>	<p>TWO openings, each at least: 1 square inch per 4,000 Btuh of all appliances in the room — OR — ONE opening **, each at least: 1 square inch per 3,000 Btuh of all appliances in the room</p>
 <p>d</p> <p>Other appliances, Vent pipe, Air pipe, (2) Air openings, 0 to 12", Outside</p> <p><small>EVG-007d dir exh</small></p>	<p>TWO openings, each at least: 1 square inch per 4,000 Btuh of all appliances in the room — OR — ONE opening **, each at least: 1 square inch per 3,000 Btuh of all appliances in the room</p>	<p>TWO openings, each at least: 1 square inch per 4,000 Btuh of all appliances in the room — OR — ONE opening **, each at least: 1 square inch per 3,000 Btuh of all appliances in the room</p>
<p>** NOTICE: Requirements for using the SINGLE air opening option.</p>	<p>A single combustion air opening can be used for cases b, c or d above, sized as listed, provided that:</p> <ul style="list-style-type: none"> • The single opening must communicate directly to the outdoors or to a space that communicates directly with outdoors (NOT to an interior space). • The top of the opening must be within 12 inches of the ceiling. • The free area of the opening must be at least equal to the sum of the areas of all equipment vent connectors in the space. 	
<p>SPECIAL EXCEPTION FOR LARGE SPACES:</p>	<p>NO combustion air openings are needed if the boiler (and other appliances) are installed in a space with a volume NO LESS than 50 cubic feet per 1,000 Btuh of all appliances in the space. That is, total the input of all appliances in MBH (1,000's of Btuh), then multiply this total times 50. The building MUST NOT be of tight construction.</p> <p>Example: For a total input of 500 MBH (500,000 Btuh), the minimum volume would be 50 x 500 = 25,000 cubic feet.</p>	



DIRECT EXHAUST — Sidewall

Allowable vent/air pipe materials & lengths

WARNING Use only the vent materials listed in Figure 2, page 4 in this instruction. Provide pipe adapters if specified.

1. Locate the termination such that the total air piping and vent piping from the boiler to the termination will not exceed the maximum length given in Figure 1, page 3.

Determine termination location

1. The vent terminations must be installed as shown in Figure 5 and in Figure 6, page 9.
2. The terminations must comply with clearances and limitations shown in Figure 3, page 5.
3. Locate the termination so it is not likely to be damaged by foreign objects, such as stones or balls, or subject to buildup of leaves or sediment.

Multiple vent/air terminations

1. Terminate each vent of multiple direct exhaust Evergreen® boilers as described in this instruction or the boiler manual for individual vents.
2. Space terminations as required for best installation practices and required maintenance.
 - a. External venting greater than 4 feet requires an enclosure around the vent pipe. The vent termination must exit through the enclosure as shown in Figure 5, page 8, maintaining all required clearances.

Prepare wall penetration

NOTICE Where the vent penetrates an outside wall, the annular space around the penetration must be permanently sealed using approved materials to prevent entry of combustion products into the building.

1. Wall penetration:
 - a. Cut a rough opening large enough to clear the diameter of the metal thimble used.

Figure 5 INSTALLATION SEQUENCE — Direct exhaust sidewall

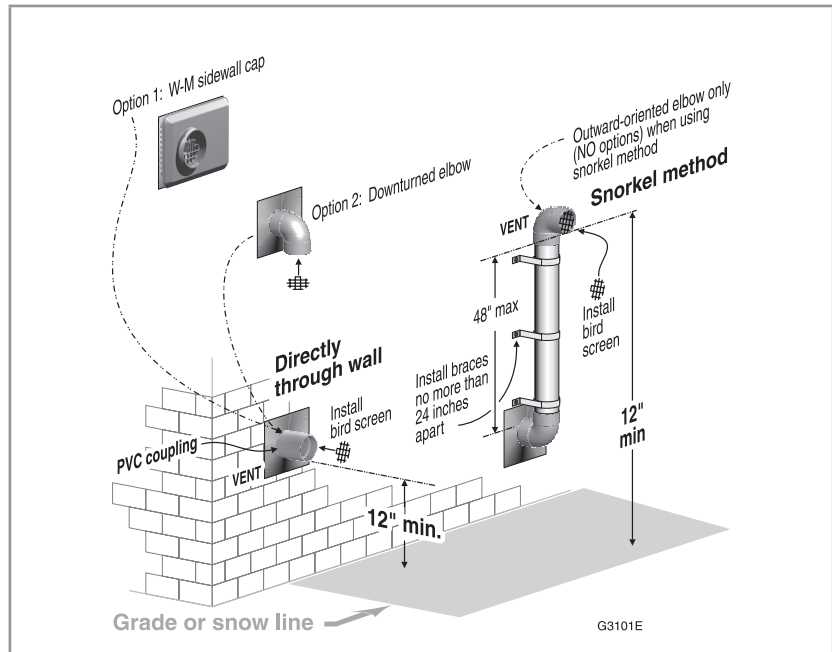

- Step 1** Read and follow all instructions in this instruction. **DO NOT proceed with vent installation until you have read page 19 through page 25 in the boiler manual.**
- Step 2** Install the boiler in a location that allows proper routing of vent piping to the selected sidewall location.
- Step 3** Make sure the selected sidewall termination location complies with Figure 3, page 5.
- Step 4** Use only the vent materials listed in Figure 2, page 4. Provide pipe adapters where required. Vent piping length must not exceed the value shown in Figure 1, page 3.
- Step 5** Prepare the sidewall penetration and secure the sidewall plate as instructed in this section. See “Prepare wall penetration” and “Termination and fittings” on page 9.
- Step 6** The vent piping can terminate using the Weil-McLain vent/air plate (without air piping connected). It can also terminate using a coupling or down-turned elbow, or snorkeled and terminated with an elbow. See illustration above. The coupling or elbow must butt against the outside plate.
- Step 7** Install vent piping between the boiler and the sidewall opening. Slope horizontal piping downward toward the boiler at least 1/4 inch per foot. Prepare the sidewall penetration and secure the sidewall plate as instructed in this section. See “Install Weil-McLain vent/air plate” on page 27 in the boiler manual.
- Step 8** Install pipe supports every 5 feet on both the horizontal and vertical runs. Install a hanger support within 6 inches of any upturn in the piping.
- Step 9** Attach the vent termination exterior piping, if used: Use any of the configurations shown above, as needed to ensure clearance above grade or snow line.
- Step 10** The vent pipe may run up as high as 4 feet with no enclosure. The vent pipe must be secured with braces, and all clearances and lengths must be maintained. Space braces no further than 24 inches apart.
- Step 11** External venting greater than 4 feet requires an insulated enclosure around the vent and air pipes. The vent and air terminations must exit through the enclosure as shown in the illustration above, maintaining all required clearances.



DIRECT EXHAUST — Sidewall *(continued)*

- a. Provide metal cover plates (item 2, Figure 6). The outer plate **MUST** provide a stop to prevent the vent elbow from being pushed inward. (See NOTICE below.) Hole diameters in the metal plates must be $3\text{-}\frac{5}{8}$ " for PVC pipe. For AL29-4C vent pipe and coupling (or elbow) — size hole large enough to clear vent pipe, but small enough to prevent the coupling (or elbow) from being pushed through.

NOTICE The Weil-McLain sidewall termination kit supplied with each boiler includes metal plates with two openings. These plates can be trimmed and used for direct exhaust vent termination cover plates when the vent diameter used matches the hole size in the plates provided with the boiler.

- b. Insert the galvanized metal thimble (by installer) in the vent pipe hole as shown in Figure 6.
1. Follow all local codes for isolation of vent pipe when passing through floors or walls.

Termination and fittings

1. If using a coupling or elbow for the termination, prepare the vent termination fitting (Figure 6, page 9) by inserting a bird screen. Bird screens are included in this kit.
2. You can install the vent termination using either of the configurations shown in Figure 5, page 8.
3. Maintain the required dimensions of the finished termination piping as shown in Figure 5, page 8.
4. Do not extend exposed vent pipe outside of the building more than shown in this document. Condensate could freeze and block vent pipe.

Figure 6 DIRECT EXHAUST — Sidewall — termination assembly and termination options — all parts by installer except where shown otherwise

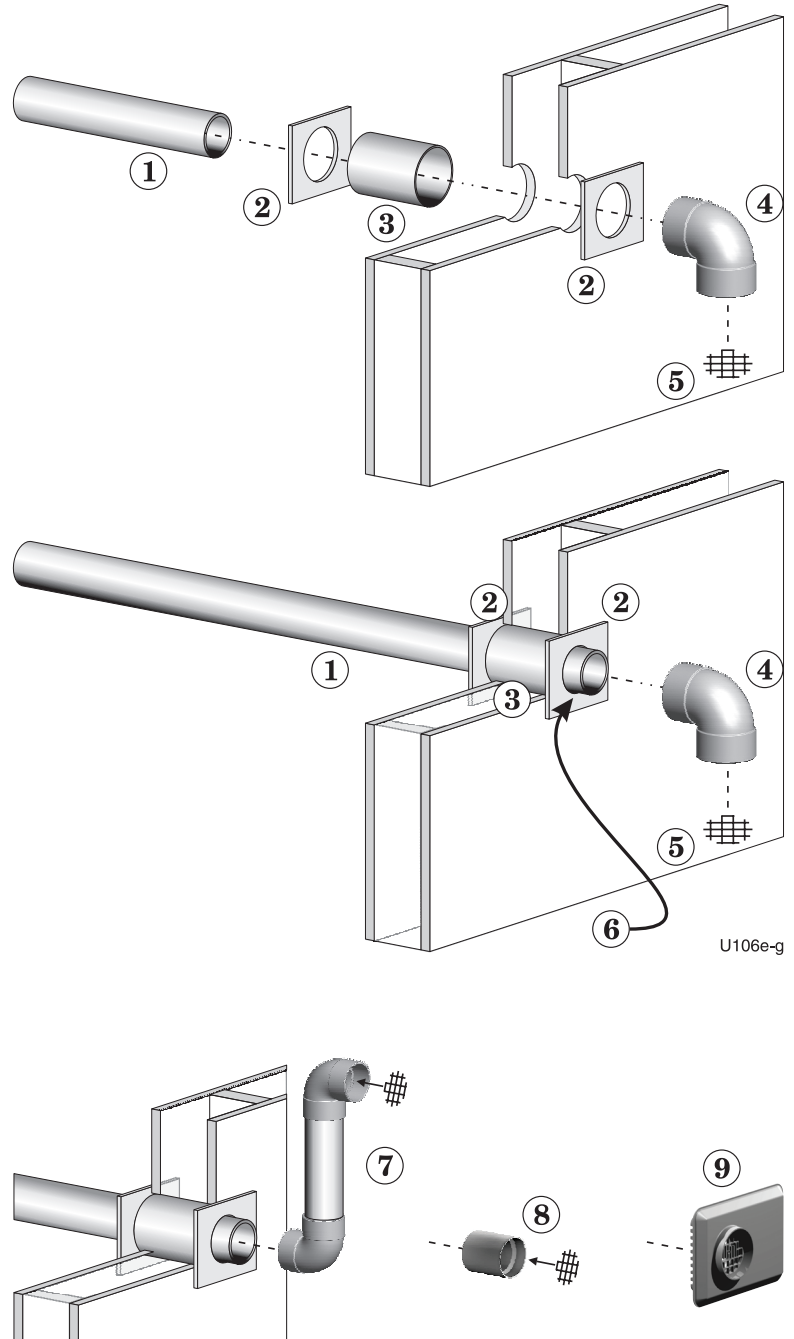

LEGEND for Figure 6

- | | |
|---|---|
| 1 | Vent piping |
| 2 | Cover plates |
| 3 | Galvanized thimble |
| 4 | Vent termination elbow |
| 5 | Bird screen |
| 6 | Extend vent pipe through outside plate enough to attach termination coupling (or elbow when snorkeled). |
| 7 | Snorkel option (to elevate vent termination) — requires bird screen |
| 8 | Coupling option — requires bird screen |
| 9 | Weil-McLain termination plate option (plate is supplied with boiler) — bird screen not required |



DIRECT EXHAUST — Vertical

Allowable vent/air pipe materials & lengths

WARNING Use only the vent materials listed in Figure 2, page 4. Provide pipe adapters if specified.

1. Locate the termination such that the total vent piping from the boiler to the termination will not exceed the maximum length given in Figure 1, page 3.

Determine termination location

1. The vent terminations must be installed as shown in Figure 7, page 10.
2. The terminations must comply with clearances and limitations shown in Figure 3, page 5.
3. Locate the termination so it is not likely to be damaged by foreign objects, such as stones or balls, or subject to buildup of leaves or sediment.

Multiple vent/air terminations

1. Terminate each vent of multiple direct exhaust Evergreen® boilers as described in this instruction or the boiler manual for individual vents.
2. Space terminations as required for best installation practices and required maintenance.

Prepare roof penetration

1. Vent pipe penetration:
 - a. Cut a hole for the vent pipe. For either combustible or noncombustible construction, size the vent pipe hole at least 0.5" larger than the vent pipe diameter.
 - b. Hole diameter in the metal plates must be at least 4" for PVC pipe. For AL29-4C vent pipe and coupling (or elbow) — size hole 0.5" larger than vent pipe outside diameter.
 - c. Insert a galvanized metal thimble in the vent pipe hole.
2. Follow all local codes for isolation of vent pipe when passing through floors, ceilings and roofs.
3. Provide flashing and sealing boots sized for the vent pipe.

NOTICE Where the vent penetrates the roof, the annular space around the penetration must be permanently sealed using approved materials to prevent entry of combustion products into the building.

Figure 7 INSTALLATION SEQUENCE — Direct exhaust vertical

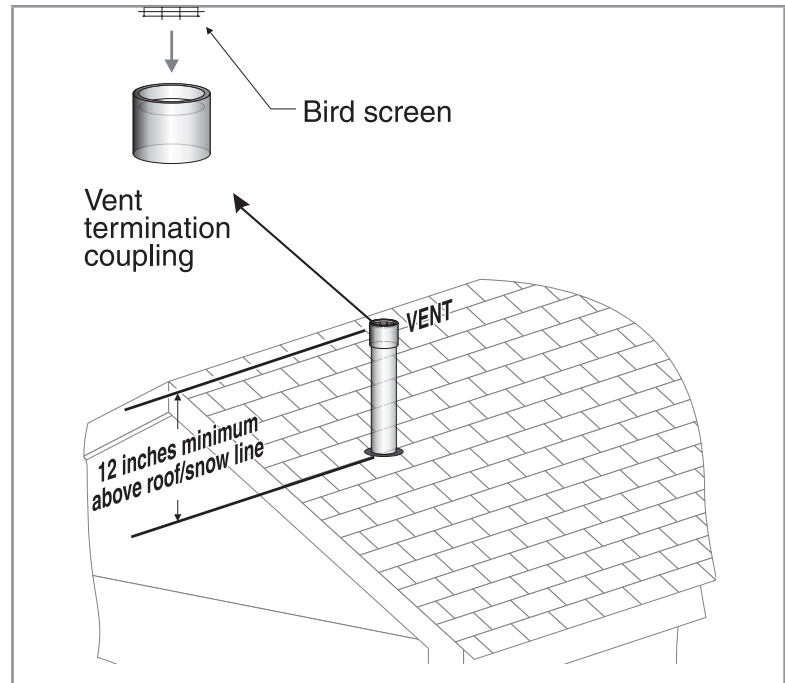

- Step 1** Read and follow all instructions in this instruction. **DO NOT proceed with vent/air installation until you have read page 19 through page 25 in the boiler manual.**
- Step 2** Install the boiler in a location that allows proper routing of all vent to the selected sidewall location.
- Step 3** Make sure the selected vertical termination location complies with Figure 3, page 5.
- Step 4** Use only the vent materials listed in Figure 2, page 4. Provide pipe adapters where required. Vent piping lengths must not exceed the values shown in Figure 1, page 2.
- Step 5** Prepare the vertical penetration and secure penetration components as instructed in this section. See “Prepare roof penetrations” and “Termination and fittings” on page 9.
- Step 6** The vent piping must terminate in a coupling pointed upward as shown above.
- Step 7** Install vent piping between the boiler and the vertical termination. Slope horizontal piping downward toward the boiler at least 1/4 inch per foot. Install pipe supports every 5 feet on both the horizontal and vertical runs. Install a hanger support within 6 inches of any upturn in the piping.
- Step 8** Maintain minimum clearance of 3/16 inch between vent pipe and any combustible wall or material.
- Step 9** Insert the vent piping through the vertical penetration and secure the termination coupling.
- Step 10** Maintain clearances shown above. Vent terminations must be fitted with a bird screen as shown.



Direct Exhaust, air piping and boiler connections

Follow termination instructions

Read and follow all instructions for the termination type used before proceeding with this page. Follow all instructions provided by vent pipe manufacturer.

WARNING Use only materials from the manufacturers listed in Figure 2, page 4.

Installing vent and air piping

Polypropylene For polypropylene applications, comply with any additional requirements in the vent system manufacturer's instructions. Provide 4" PVC-to-PP transition pieces at the boiler vent and air connections. PP adapter must have smooth, straight section of pipe to insert in to the boiler vent and air connections and must fit and seal tightly. PP adapters with their own seal which would interfere with the internal seal of the boiler vent or air connections must not be used. Refer to page 117 in the boiler manual for a list of compliant adapters. Install a locking collar at every joint.

AL29-4C S.S. For AL29-4C vent pipe applications, comply with any additional requirements in the vent system manufacturer's instructions. Provide a 4" PVC transition piece at the boiler vent connection. Air piping must be PVC or CPVC. Connect to the boiler air piping only with 4" PVC (use a transition piece for 3" air pipe). Provide 4" PVC connections at the termination if using the W-M termination plate. Provide 3" or 4" PVC transitions at the termination if using a PVC concentric vent kit.

1. Work from the boiler to vent termination. Do not exceed the lengths given in the previous pages for vent piping.
2. See Figure 8 for attaching vent pipe at the boiler. Connections must be 4" PVC or CPVC only — use transitions if needed to adapt to other material or size (3"). When transitioning to 3", use tapered reducer.
3. Cut pipe to required length.
4. Dry assemble entire vent or air piping to ensure proper fit before assembling any joint.
5. Maintain minimum clearance of 3/16 inch between vent pipe and any combustible wall or material.
6. Seal wall or floor penetration openings following local code requirements.
7. Assembling PVC or CPVC: (**Polypropylene** **AL29-4C S.S.** — follow pipe manufacturer's instructions for preparation and assembly)
 - a. Deburr inside and outside of pipe ends.
 - b. Chamfer outside of each pipe end to ensure even cement distribution when joining.
 - c. Clean all pipe ends and fittings. Dry thoroughly.
 - d. For each joint:
 - Handle fittings and pipes carefully to prevent contamination of surfaces.
 - Apply primer liberally to both joint surfaces — pipe end and fitting socket.
 - While primer is still damp, lightly apply approved cement to both surfaces in a uniform coating.
 - Apply a second coat to both surfaces. Avoid using too much cement on sockets to prevent cement buildup inside.
 - With cement still wet, insert pipe into fitting, twisting ¼ turn. Make sure pipe is fully inserted.
 - Wipe excess cement from joint. Check joint to be sure a smooth bead of cement shows around the entire joint.

Figure 8 Boiler vent and air connections

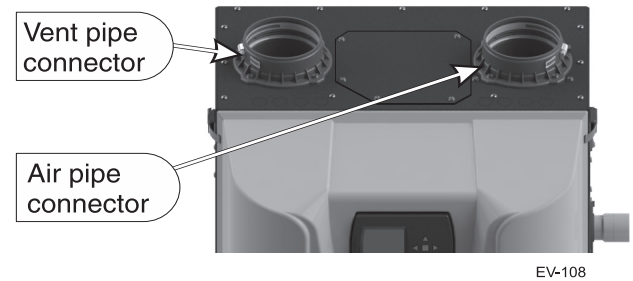

WARNING ADAPTERS — Use adapters if using other than 4-inch PVC or CPVC. This is required for different materials or if using 3-inch pipe.

1. Use ONLY 4" PVC or CPVC pipe at boiler connections.
2. Clean and deburr inside and outside of both ends of air and vent pipes. Chamfer boiler end of vent pipe for ease of insertion.

WARNING The vent pipe end must be smooth and chamfered to prevent possible damage to sealing gasket in vent pipe adapter.

3. Inspect vent or air adapter (above) — verify no obstructions or foreign objects inside.
4. Loosen clamp screw.
5. Measure 3 inches from end of pipe and make a mark with felt-tip pen.
6. Loosen adapter clamp screw.
7. Apply small amount of silicon grease to end of pipe to ease insertion.
8. Insert pipe into adapter.
9. Slide pipe down until the 3 inch mark is reached.

WARNING Do not apply excessive force or bend the adapter or flue/air pipe when inserting. The adapter or seal could be damaged. If any portion of the vent or air system is damaged, it must be replaced.

10. Secure vent or air pipe by tightening the adapter clamp securely. Do not overtighten.
11. The seal is accomplished with the internal gasket. The clamp is only to hold the pipe in place.

WARNING When transitioning to 4-inch to 3-inch, use tapered reducer with 4" nipple (6" Length or greater). Do NOT use 4-inch to 3-inch bushing. Bushing will NOT seal in boiler adapter.

DIRECT EXHAUST ONLY

WARNING DIRECT EXHAUST installations — air inlet opening protection: Obtain a bird screen (sized for air inlet fitting - included in kit). Insert the bird screen into the air inlet fitting to prevent foreign objects from entering the opening.



WARNING USE SWEEP ELBOWS FOR ALL VENT AND AIR PIPING — DO NOT use short radius elbows for vent or air piping. Boiler performance could be affected.

