

Section Assembly Parts

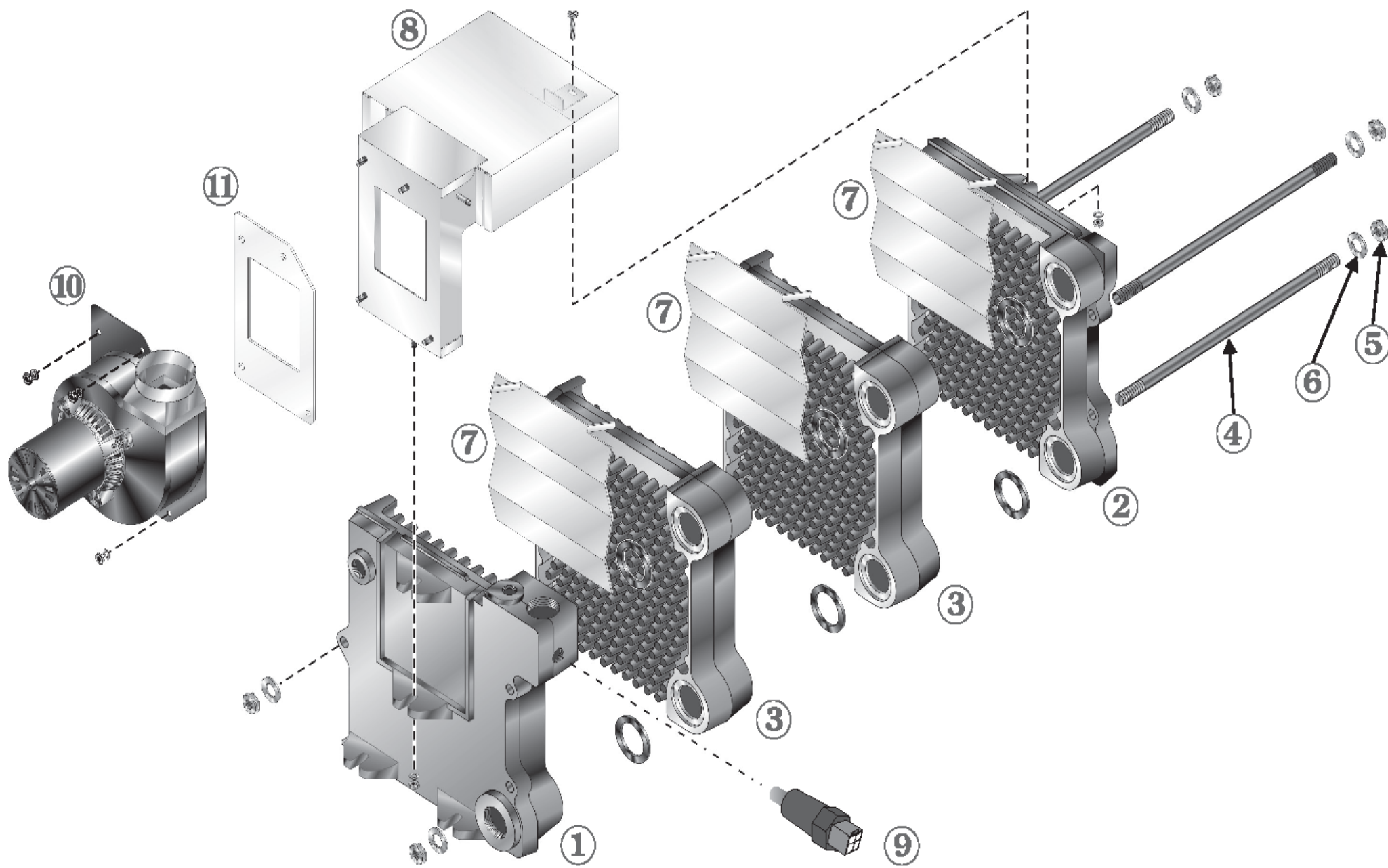

Section Assembly Parts

Index		Notes	Part No.	
1			311-103-851 Left Hand End Section 51124	
2			311-103-821 Right Hand End Section 51128	
3			311-103-845 Intermediate Section, Cast #51127	
			321-114-362 Replacement Section Assembly	
			381-354-527 Section Replacement Kit	
4			560-234-502 7/16" X 15" Tie Rod Without Nut	
5			561-928-235 Regular Hex Nut 7/16"	
6			562-248-684 7/16" Washer Medium Plain Split Lock	
7			460-003-017 Radiation Plate	
8			381-359-289 Collector Hood and Transition Assembly	
9			381-356-589 Temperature/LWCO Sensor	
10			381-359-295 Inducer Fan Assembly Kit	

Index		Notes	Part No.	
11			590-317-627 Gasket, Inducer Terminator	

Base Assembly Parts

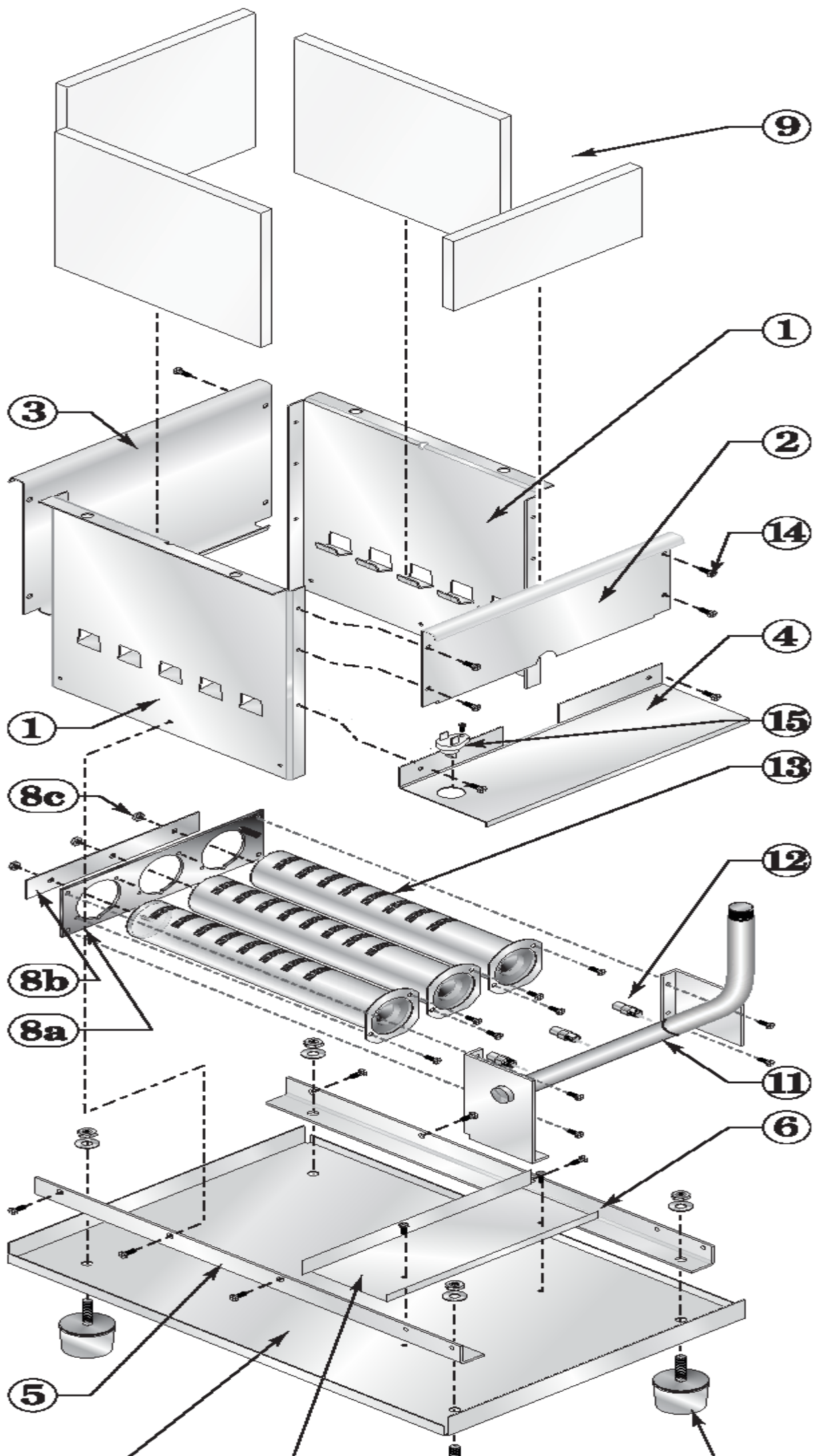

Base Assembly Parts

Index		Notes	Part No.	
			381-354-339 Base Assembly Kit	
1			Base Side Panel	
2			Base Front CrossTie Assembly	
3			Base Back Cross-Tie Assembly	
4			Burner Shield	
5			Base Pan Angle, Left Side	
6			Base Pan Angle, Right Side	
7			Base Pan	
7A			Base Pan Air Baffle	
8A			450-003-692 Burner Mounting Panel	
8B			550-320-162 Rear Spacer Strip	
8C			550-320-170 Nut, HEX 5mm Zinc Plated	
9			381-354-332 Base Insulation Kit	
10			550-320-219 Boiler Leg Kit	
11			591-126-737 Manifold	
12			560-529-111 Burner Orifice - LP Gas, Sea Level 1.60mm	
12			560-529-126 Burner Orifice - Natural Gas, Sea Level 2.55mm	

Index		Notes	Part No.	
13			512-200-076 Burner	
14			562-135-710 Screw, 10-32 x 0.38 STP type 23 HEX, Washer Heat Slot	
15			512-050-230 Rollout Thermal Fuse Element, 228°C	

Control Parts

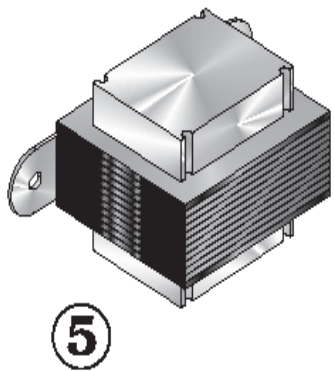
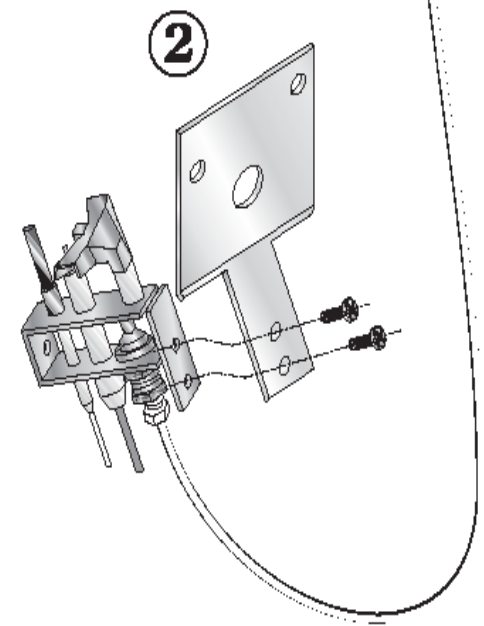
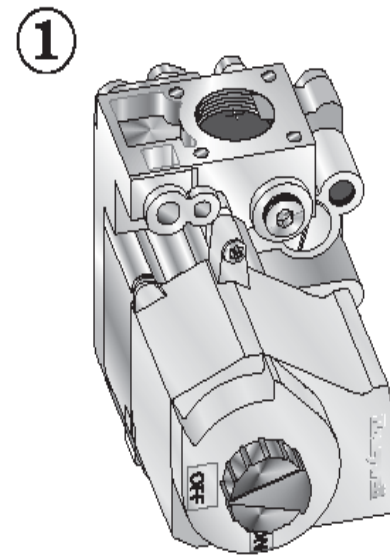
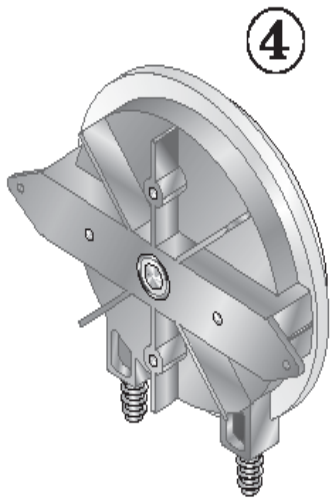

Control Parts

Index		Notes	Part No.	
			Natural Gas Components	
1			511-044-381 Combination Gas Valve (NG), ½" x ½" N.P.T., 24 Volt	
2			511-330-080 Pilot Assembly Kit with Orifice and Aluminum Pilot Gas Tubing	
			Propane Gas Components	
1			511-044-354 Gas Valve (LP), ½" x ½"	
2			511-330-081 Pilot Assembly Kit with Orifice and Aluminum Pilot Gas Tubing	
			Conversion Kits	
			510-811-262 Natural To LP Conversion Kit CGi	
			510-811-263 LP To Natural Conversion Kit CGi	
			450-003-689 Pilot Bracket	
			Machine Screw, Pan Head Phillips, 1032 x .19" Zinc Plated	

Index		Notes	Part No.	
			381-356-528 Circulator Wiring Harness Kit with Molex	
3			381-330-040 Control Module	
			591-391-978 Wiring Harness, Controls To Control Module	
			591-391-975 Wire Harness, Power, J Box To Module	
			591-392-006 Thermostat Harness	
			591-391-995 Wire Harness, WaterTemperature/ LWCO Sensor	
			591-391-980 Wire Harness - Inducer Motor to Control Module	
4			381-359-282 Air Pressure Switch	
5			381-356-578 Control Transformer, 24 Volt, 40 VA	
			590-317-650 Air Pressure Switch Tubing, Red, .12 ID Silicone, 17"	

Index		Notes	Part No.	
			590-317-651 Air Pressure Switch Tubing, White, .12 ID Silicone, 19"	

Water Trim Parts

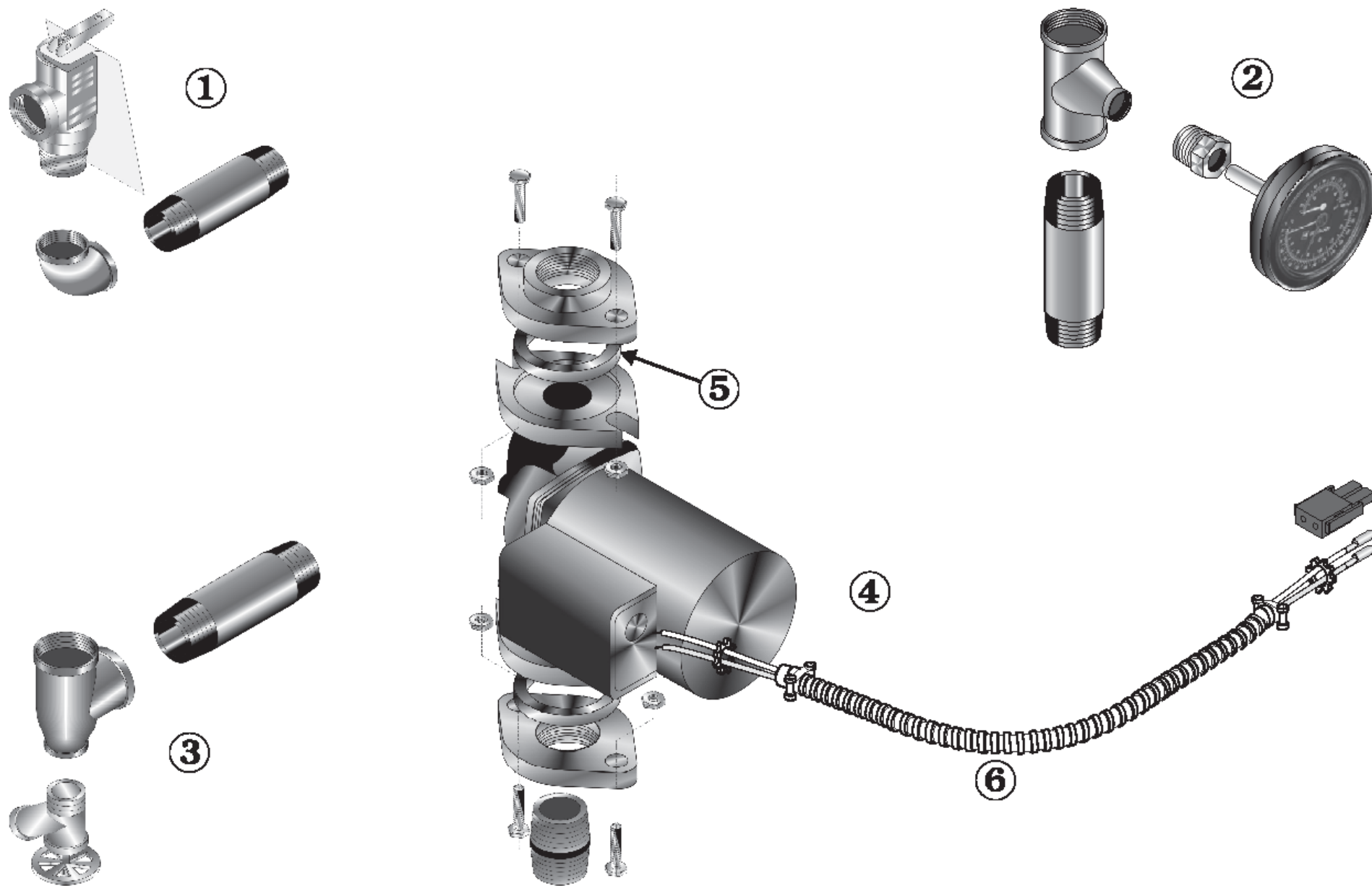

Water Trim Parts

Index		Notes	Part No.	
1			383-500-095 Relief valve	
2			380-000-000 Pressure & temperature gauge	
3			511-210-423 Drain Valve, ¾" N.P.T., 1½" Shank, Brass	
3			511-246-392 Drain Valve, ¾" x 1½" Shank	
4			511-405-153 Circulator	
5			590-317-535 Universal Circulator Gasket	
			381-354-525 Circulator Hardware Kit	
6			381-356-528 Circulator Wiring Harness Kit with Molex	

Jacket Assembly Parts

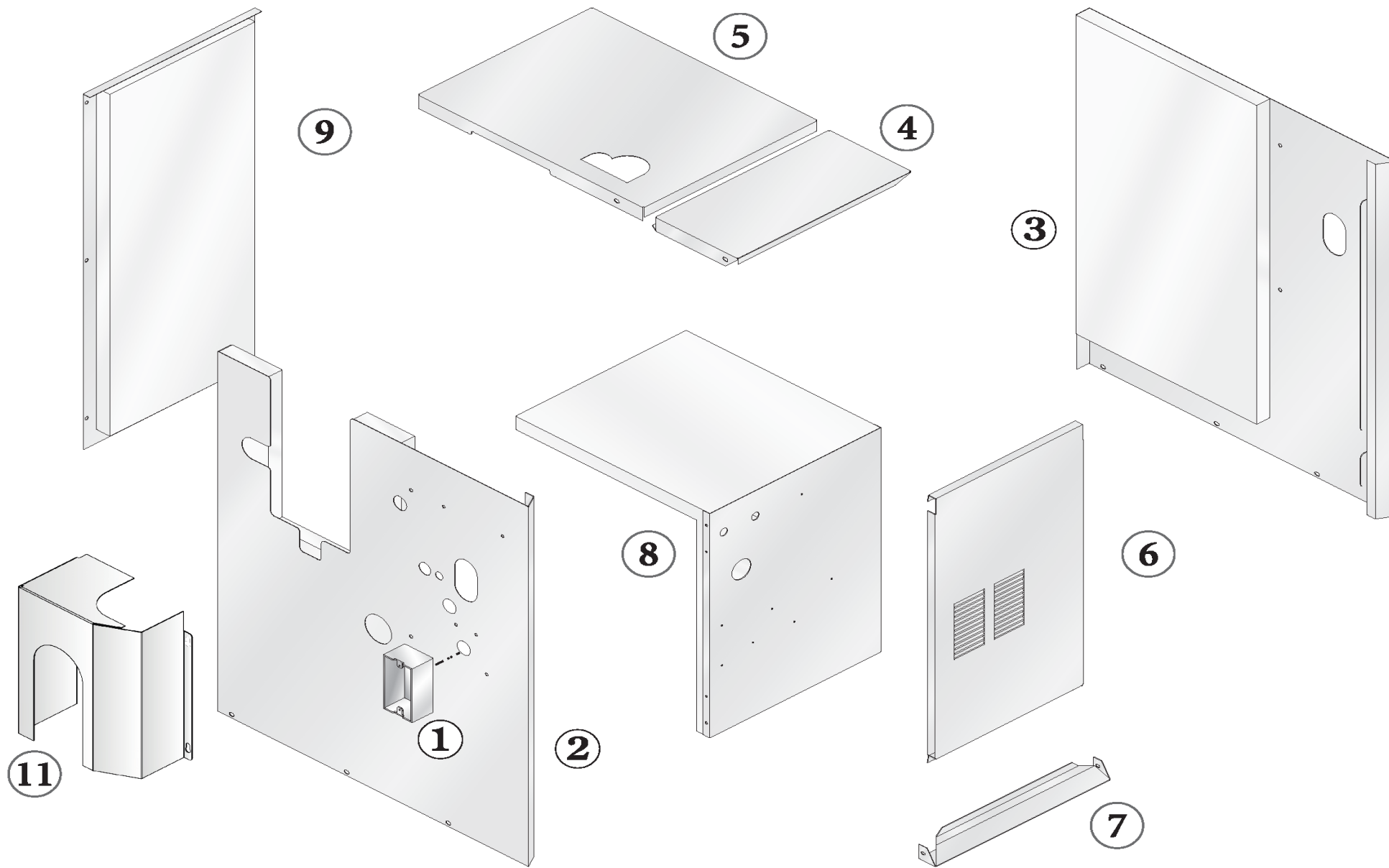

Jacket Assembly Parts

Index		Notes	Part No.	
1			Junction box, 2 x 4	
2			381-359-218 Jacket Panel, Left Side, With Insulation, for NG	
2			381-359-225 Jacket Panel, Left Side, With Insulation, for LP	
3			381-359-229 Jacket Panel, Right Side, With Insulation	
4			381-359-232 Jacket Panel, Top Front	
5			381-359-244 Panel, top rear, with insulation	
6			381-359-256 Panel, door	
7			381-359-262 Jacket Cross Tie, Bottom Front	
8			381-359-268 Jacket Panel, Interior, With Insulation	
9			381-359-274 Jacket Panel, Rear, With Insulation	
11			381-359-200 Blower Cover	
			381-359-278 Touch Up Paint - Cloud	

Index		Notes	Part No.	
			384-000-141 Touch Up Paint - Slate	