

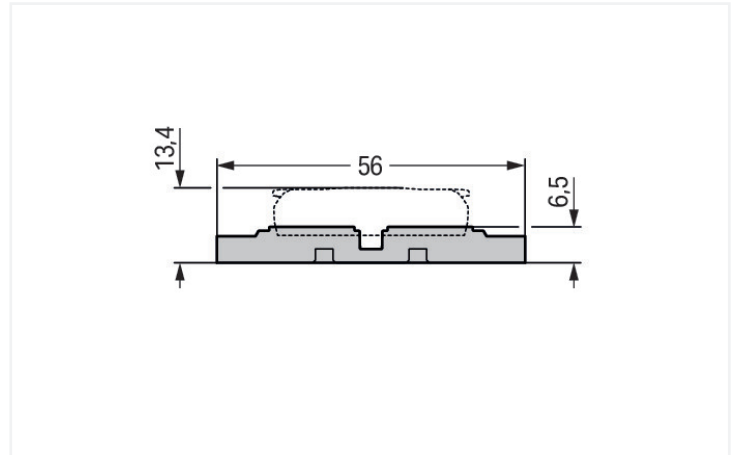

## Data Sheet | Item Number: 221-2521

Mounting carrier; 1-way; for inline splicing connector with lever; for screw mounting;  
gray

<https://www.wago.com/221-2521>

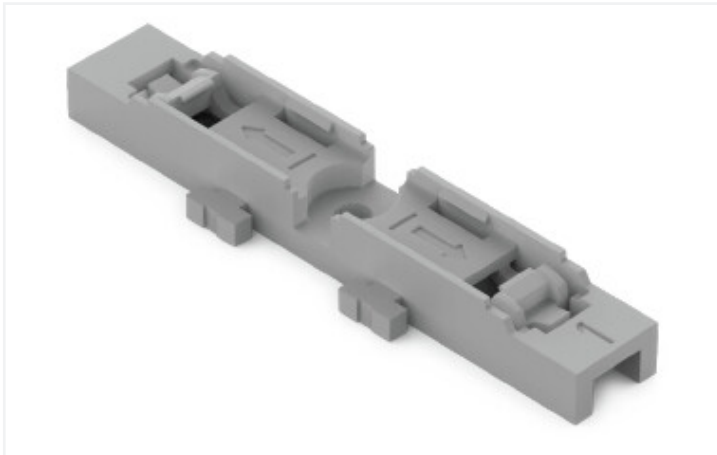

Color:  gray

### Physical data

Width	11.8 mm / 0.465 inches
Height from the surface	6.5 mm / 0.256 inches
Depth	56 mm / 2.205 inches

### Material Data

Note (material data)

[Information on material specifications can be found here](#)

Color	gray
Fire load	0 MJ
Weight	1.6 g

### Commercial data

ETIM 8.0	EC002848
ETIM 7.0	EC002848
PU (SPU)	25 (5) pcs
Packaging type	Box
Country of origin	CN
GTIN	4066966119923
Customs tariff number	39269097900

## Downloads

### Environmental Product Compliance

Compliance Search

Environmental Product  
Compliance 221-2521



## Documentation

Additional Information

Technical Section

pdf  
2142.18 KB



## CAD/CAE-Data

CAD data

2D/3D Models  
221-2521



CAE data

EPLAN Data Portal  
221-2521



ZUKEN Portal  
221-2521



## Installation Notes

### Installation

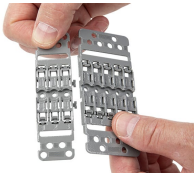
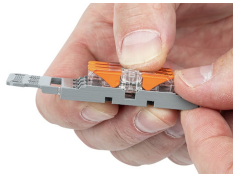

Strain relief

