

PACKAGED HEAT PUMP

75012783

RP
A

The sections that appear on this illustration are for all options.
Sections and options will appear in the Parts List if factory installed

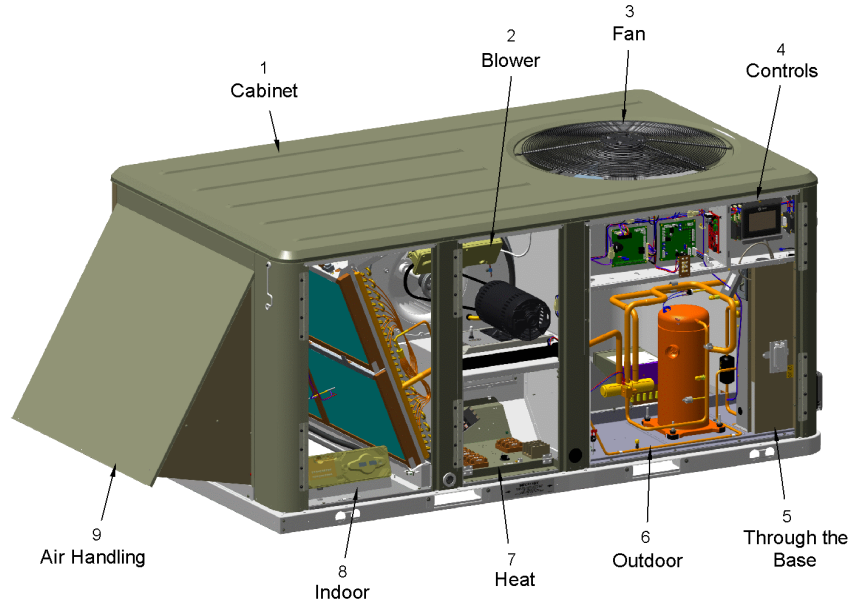

This is a typical illustration. The unit in the field may not appear exactly as shown.

Part No.	Reference No.	Quantity	Description
75011721	1		UNIT BASE COMPONENTS
75012614	2		BLOWER
75012613	3		FAN - OUTDOOR
75012787	4		CONTROL PANEL
75011851	4		HARNESS - COMMON CONTROLS
75012815	4		HARNESS - CONTROL, 2 STAGE COMPRESSOR
75011857	4		HARNESS - CONTROLS WITH CTS
75012838	4		HARNESS - OPTIONS
75012825	4		HARNESS - POWER
75012826	4		HARNESSES - POWER & CONTROLS / BELT DRIVE MOTOR
75011855	4		TERMINAL BLOCK - CONTROLS (CTB)
75012786	6		OUTDOOR COIL, COMPRESSOR
75012811	8		INDOOR COIL, FILTERS, DRAIN PAN
75010609	9		ECONOMIZER - REFERENCE ENTHALPY
NGRAPHIC	10		OPTIONAL FIELD INSTALLED ACCESSORIES
75012766	11		MODEL NUMBER DESCRIPTION, DIGITS 1-16
75012767	11		MODEL NUMBER DESCRIPTION, DIGITS 17-31

UNIT BASE COMPONENTS

75011721

REV.
A

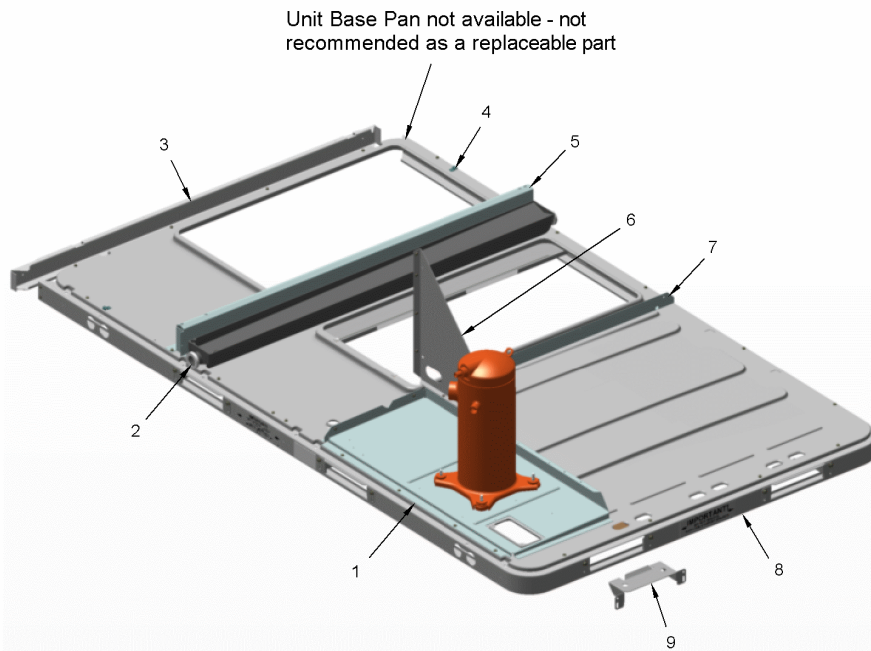

This is a typical illustration. The unit in the field may not appear exactly as shown.

Part No.	Reference No.	Quantity	Description
PLT03619	1	1	PLATE; MOUNTING, COMPRESSOR, 34.56 X 14.30
RAL00878	3	1	RAIL; END, 53 IN LENGTH
CLP01008	4	2	NO DESCRIPTION AVAILABLE
SUP04486	5	1	SUPPORT; INDOOR COIL, 51.6 INCH LENGTH
BRK03275	6	1	BRACKET; COMPRESSOR SUPPORT (3 SIDES)
ANG01324	7	1	ANGLE; TOGGLE LOCK, 51.00 X 1.80
RAL01211	8	1	RAIL; BASE, C/D CABINET
BRK03274	9	4	BRACKET; BASE SUPPORT MOUNT, 10.3 LENGTH (FORKLIFT BRACKET)

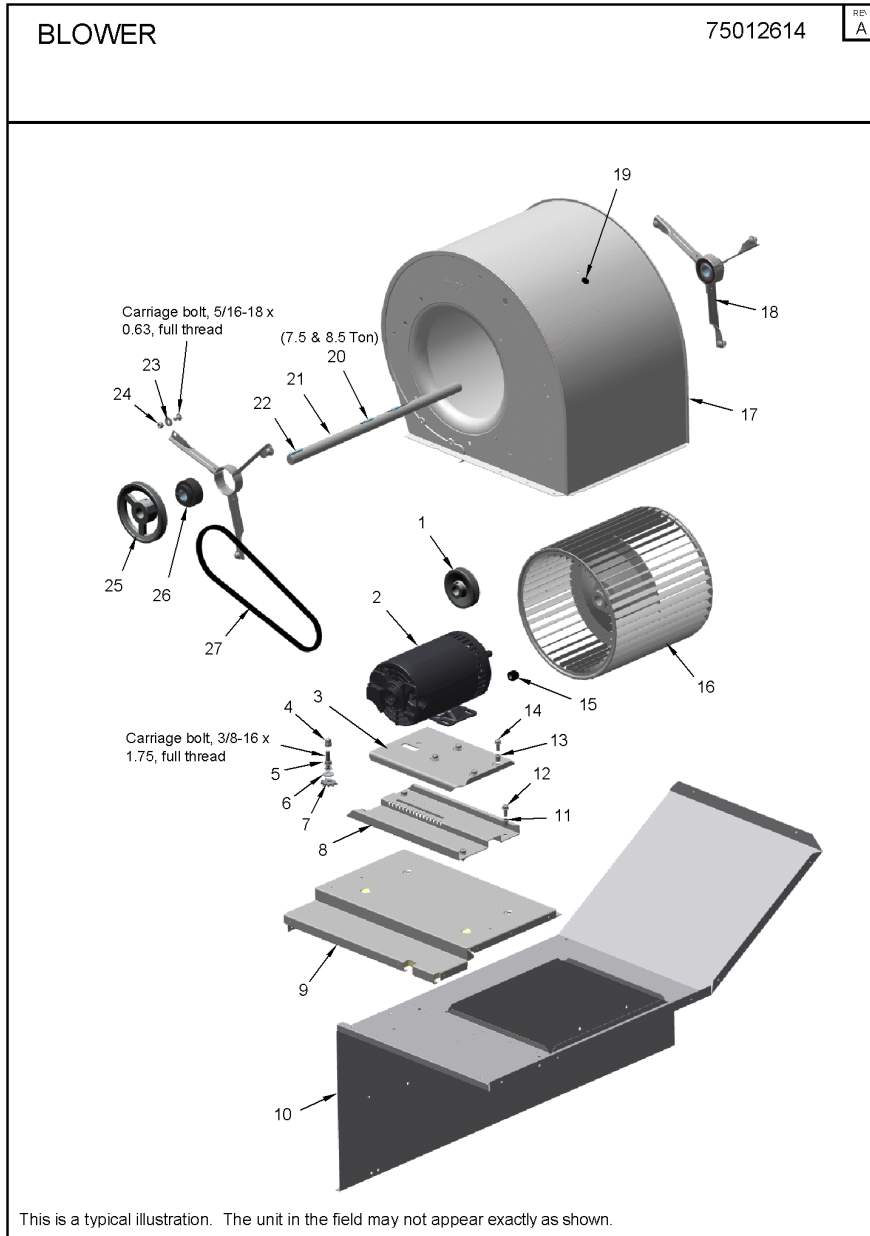

Part No.	Reference No.	Quantity	Description
KIT12166	*	1	KIT; MOTOR MOUNTING. INCLUDES (1) BRK02977, (1) BRK02978, MOUNTING HARDWARE AND BELT TENSION LABELS.
WIR09224	*	1	WIRE; HARNESS; BELT DRIVEN INDOOR MOTOR, PPM87, 16G-RD,17G-BL,76A-BK
SHE00046	1	1	SHEAVE; 1VL40, 7/8 IN. BORE
MOT13032	2	1	MOTOR; 2.0 HP AT 208-230/460/60/3. 1.5 HP AT 190/380-415/50/3, 1740 RPM, 145T FRAME, BALL BEARINGS
BRK02978	3	1	BRACKET; MOTOR MOUNTING PLATE, TOP, 11.7 X 7.8. INCLUDES (4) .31-18 HEX RIVNUTS.
NUT01042	4	1	NUT; HEX, 3/8-16 UNC, ACORN, HIGH CROWN, BELT DRIVE MOTOR BRACKET
NUT00079	5	1	NUT; .38-16
WAS00283	6	1	WASHER; PLAIN, .43 ID X 1.00 OD, .083 THK, CARBON-STL PLD
BRK02975	7	1	BRACKET; ADJUSTMENT, MOTOR (IDLER GEAR)
BRK02977	8	1	BRACKET; MOTOR MOUNTING PLATE, BOTTOM, 14.5 X 8.0. INCLUDES (4) 0.31-18 X 0.75 HEX MACH SCREWS.
INS03491	9	1	INSULATION; WRAPPER FRONT
PNL16810	9	1	PANEL; WRAPPER, TOP, 19.74 X 16.59
NUT00588	11	4	NUT; HEX RIVET, .31-18
SCR01634	12	4	SCREW; .31-18 X .75, HEX MACH
NUT00588	13	4	NUT; HEX RIVET, .31-18
SCR01634	14	4	SCREW; .31-18 X .75, HEX MACH
BUS00363	15	1	BUSHING; STRAIN RELIEF
BUS00485	19	1	BUSHING; .62 MTG W/MAX .44 ID
KEY00300	22	1	KEY; 1/4 IN X 1/4 IN X 1-1/2 IN
SHE01114	25	1	SHEAVE; AK64 X 1, 6.25 OD
BRG01579	26	2	BEARING; BALL; 1.0 BORE, BB CRTG, RUBBER MOUNT

FAN - OUTDOOR

75012613

RP
A

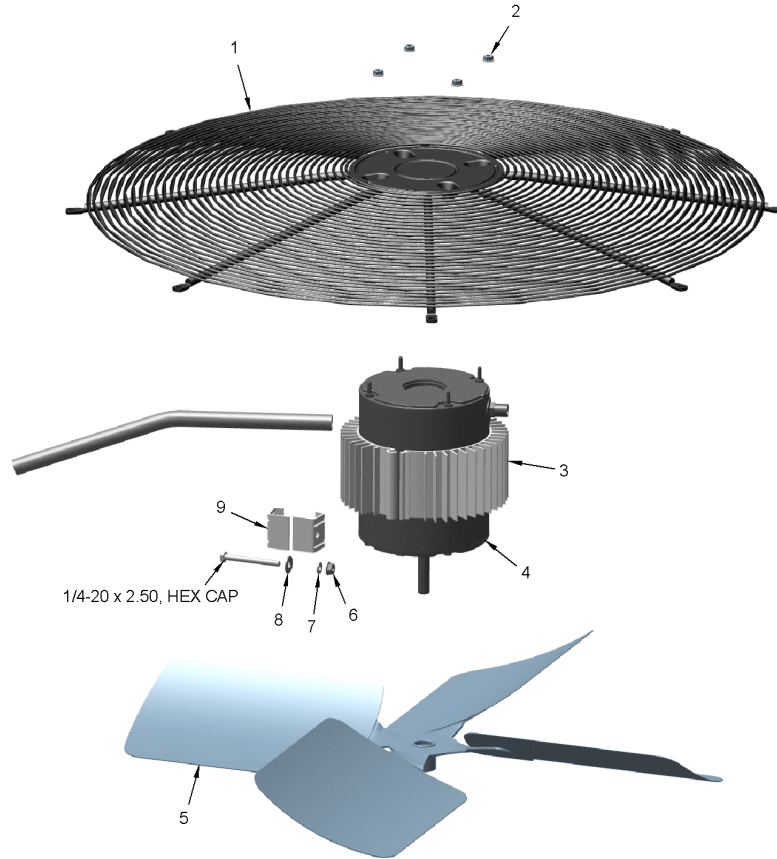

This is a typical illustration. The unit in the field may not appear exactly as shown.

Part No.	Reference No.	Quantity	Description
GRL01353	1	1	GRILLE; OUTDOOR FAN, 30.33 MTG DIA
NUT01332	2	4	NUT; SERRATED HEX FLANGE, ZINC PLATED (IF RUBBER CAP IS NEEDED ORDER IRT00017)
RNG01005	3	2	RING; EXTRUDED FIN, HEAT SINK, 3.00 WIDE, UNRESTRAINED DIM IS 7.20/6.61
MOT18648	4	1	MOTOR; AL OD MOTOR, 3 PHASE 0.7 HP, 460V
NUT00009	6	1	NUT; .25-20, HEX LOCK
WAS00670	7	1	WASHER; .26 ID X .49 OD
WAS00041	8	1	WASHER; FLAT, PLAIN, #12 .25 ID X .56 OD, .065 THK, CARBON STL-PLD
BRK00688	9	2	BRACKET; CONNECTING, HEAT SINK

CONTROL PANEL

75012787

RP
A

The parts that appear on this illustration are for all options.
Parts will appear in the Parts List if factory installed.

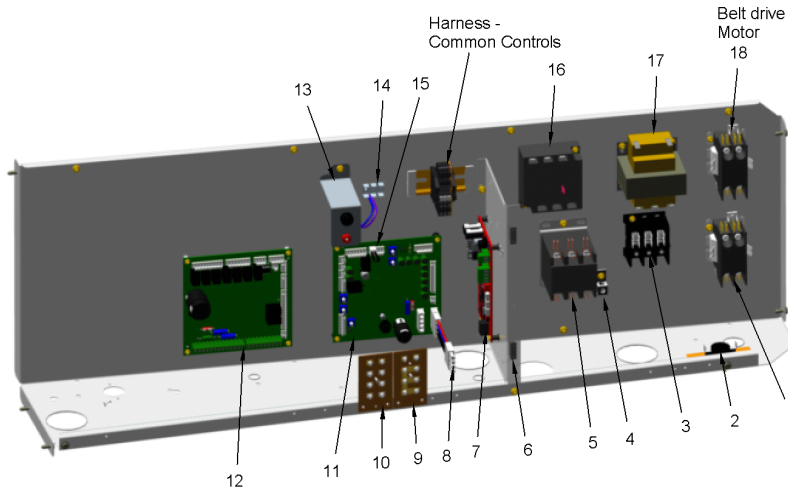

This is a typical illustration. The unit in the field may not appear exactly as shown.

Part No.	Reference No.	Quantity	Description
CTR01203	1	1	CONTACTOR; 2P, 30A, 24V COIL, 30 FLA AT 277V
CNT01405	2	1	CONTROL; TEMP, OPEN 65F, CLOSE 55F, SPST
CON00077	4	1	CONNECTOR, ELECTRIC GROUND, 14-2 AWG SOLDERLESS
CTR01870	5	1	CONTACTOR; 3 POLE, 30 FLA, W/O LUGS, 50/60 HZ, 24V COIL
CAT00043	6	2	CATCH; MAGNETIC SNAP-IN
WIR03277	8	1	WIRE; HARNESS, OPTION MODULE GENDER CHANGER. BK, BL, RD WIRES. 4 INCH LENGTH. PPM33
BLK00940	9	1	BLOCK; 6 TERMINALS (LVTB)
MOD02554	11	1	MODULE; RELIATEL OPTIONS, RTOM
MOD02919	12	1	MODULE; RELIATEL REFRIGERATION DUAL CIRCUIT COOL/HP
TER01680	14	1	TERMINAL STRIP; .25IN. FASTON
WIR03278	15	1	WIRE; HARNESS, SUPPLY AIR TEMPERING, BK WIRE, 3 INCHES LENGTH, RTOM 5J3-1 TO 5J3-2
CNT05176	16	1	CONTROL; MONITOR, 3-PHASE LINE, UNIVERSAL 180-632 VAC, PHASE AND LOSS REVERSAL
TRR00826	17	1	TRANSFORMER; 75 VA, 460-575V PRI, 24V SEC
CTR01203	18	1	CONTACTOR; 2P, 30A, 24V COIL, 30 FLA AT 277V

OPTIONS HARNESS

75012838

RP
A

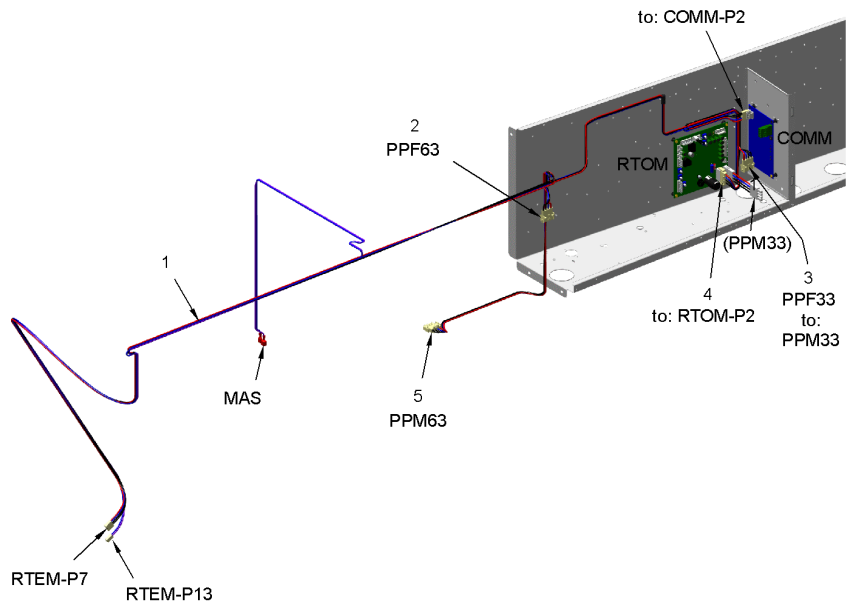

This is a typical illustration. The unit in the field may not appear exactly as shown.

Part No.	Reference No.	Quantity	Description
WIR09244	1	1	WIRE; HARNESS, CONTROLS/OPTIONS, PPF33 TO COMM-P2, PPF63 TO RTOM-P2, RTEM-P17 TO PPM63, RTEM-P23 TO MAS
HUS03378	2	1	HOUSING; SOCKET, 4 CIRCUIT
HUS03378	3	1	HOUSING; SOCKET, 4 CIRCUIT
HUS03379	4	1	HOUSING; PLUG CONNECTOR, 4 CIRCUIT
HUS03379	5	1	HOUSING; PLUG CONNECTOR, 4 CIRCUIT

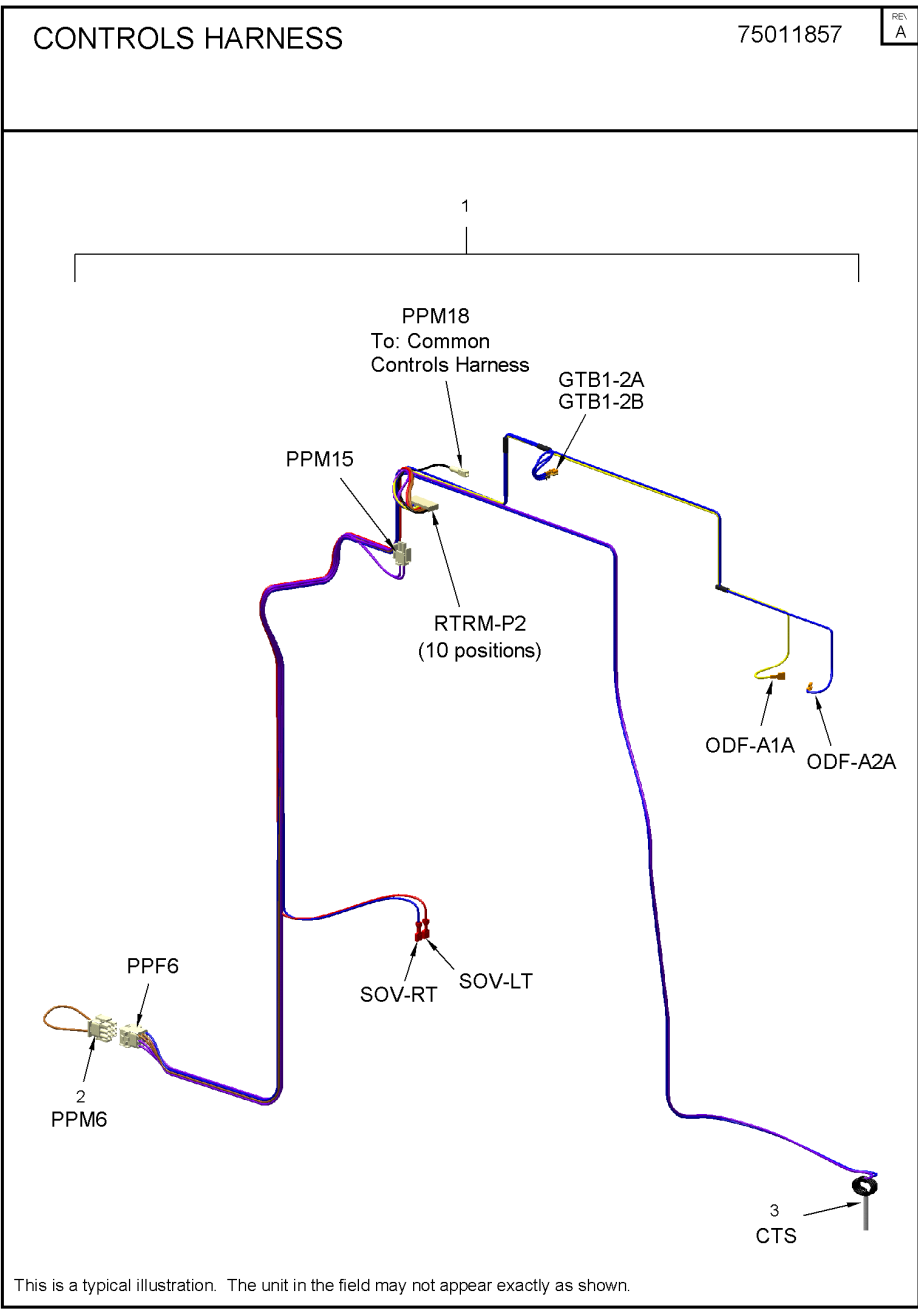

Part No.	Reference No.	Quantity	Description
WIR08680	1	1	WIRE; HARNESS, CONTROLS, INCLUDES CTS-SEN00275 & WIR08179
WIR08179	2	1	WIRE; HARNESS, NO HEAT CONFIGURATION - RELIATEL CONTROLS
SEN00275	3	1	SENSOR; THERMISTOR PROBE, -40 DEG C TO 65 DEG C, 12 INCH STRIPPED LEADS

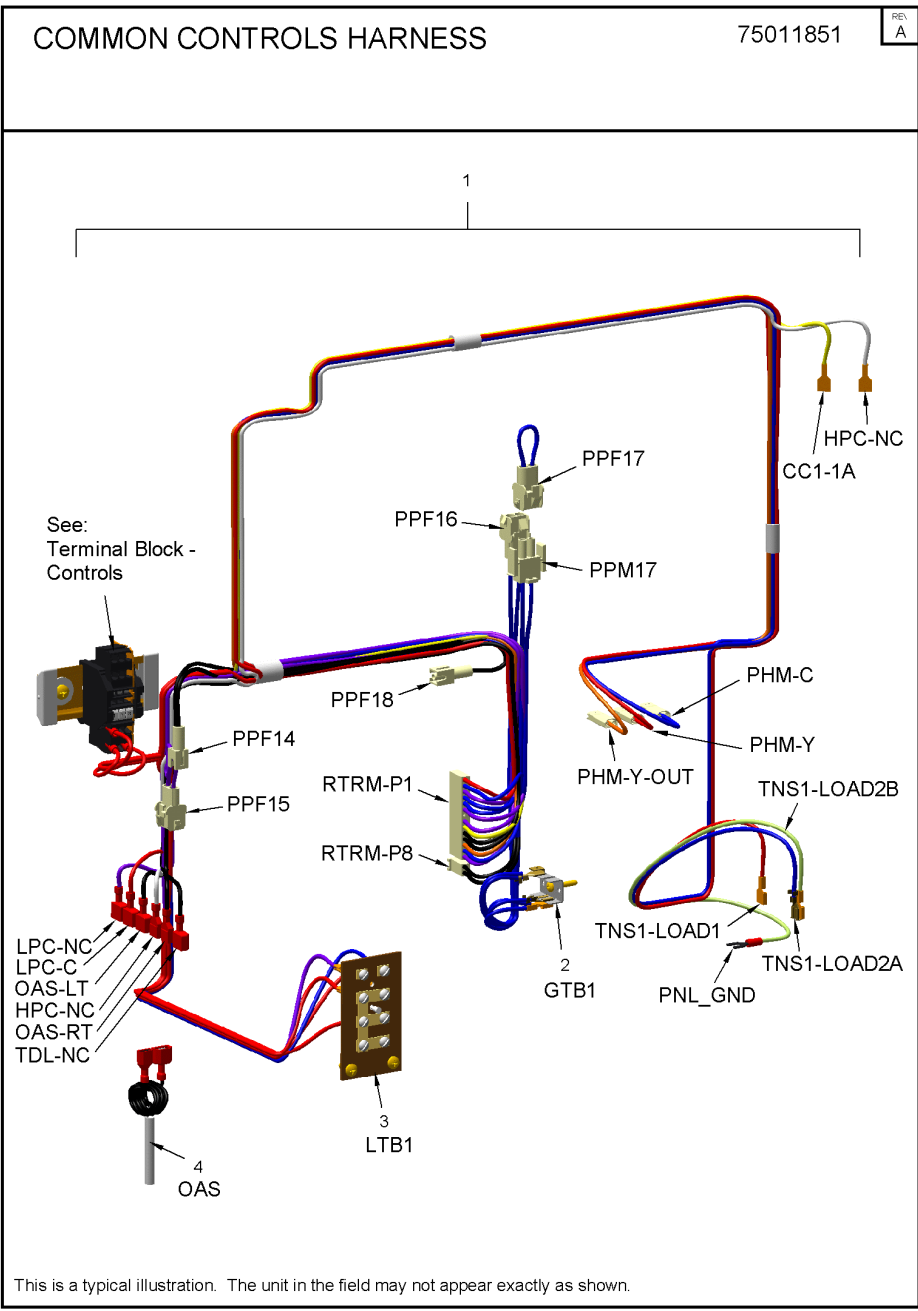

Part No.	Reference No.	Quantity	Description
WIR09263	1	1	WIRE; HARNESS, COMMON CONTROLS, INCLUDES CTB
TER01680	2	1	TERMINAL STRIP; .25IN. FASTON
BLK00940	3	1	BLOCK; 6 TERMINALS (LVTB)
BRK04441	4	1	BRACKET; OUTDOOR AIR SENSOR
GRM00039	4	1	GROMMET; RUBBER .25 ID X .05 GRV MLD
SEN01829	4	1	SENSOR; THERMISTOR PROBE, -40 TO 65C, .25 DIA X 1.75 LG W/26" PVC LEADS-INSUL QC

HARNESSES - POWER & CONTROLS

75012826

RP
A

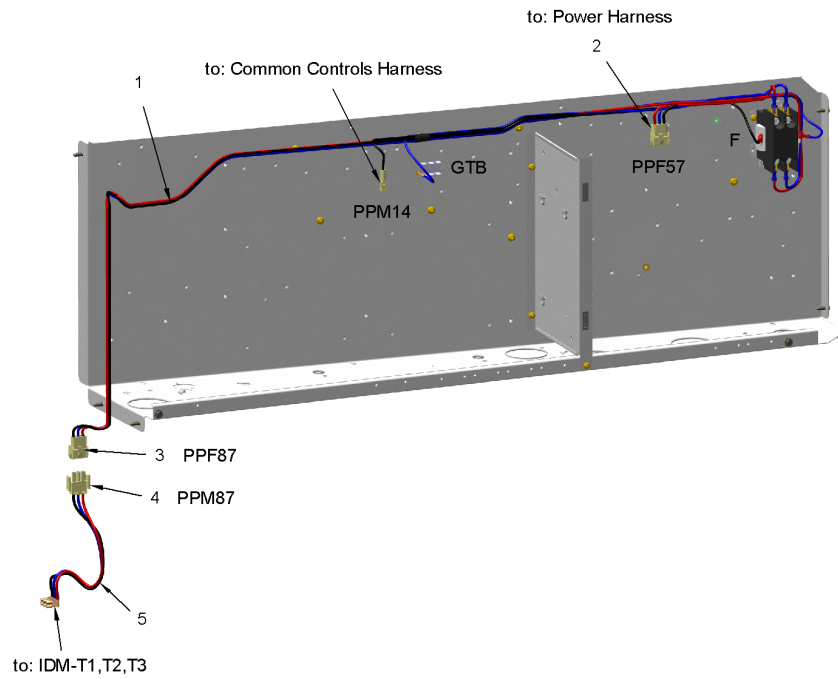

This is a typical illustration. The unit in the field may not appear exactly as shown.

Parts List Number :WSCUP10

Model Number :WSC102H4R0B00E0

Part No.	Reference No.	Quantity	Description
WIR09235	1	1	WIRE; HARNESS, PWR & CNTLS, BELT DRIVE MOTOR, PPF87, PPM14, PPF57, 16F-RD,17F-BL,101DL-BL,117S-BK,W93-RD,W94-BL, W96-BK
CON00973	2	1	CONNECTOR; 3 CKT, CAP HSG, WHITE/NATURAL
CON00973	3	1	CONNECTOR; 3 CKT, CAP HSG, WHITE/NATURAL
CON00486	4	1	CONNECTOR; PLUG HOUSING, 3 PIN MALE
WIR09224	5	1	WIRE; HARNESS; BELT DRIVEN INDOOR MOTOR, PPM87, 16G-RD,17G-BL,76A-BK

HARNESS - CONTROLS
2 STAGE COMPRESSOR

75012815

RP
A

Harness does not include RTRM, GTB, CTB, or LTB

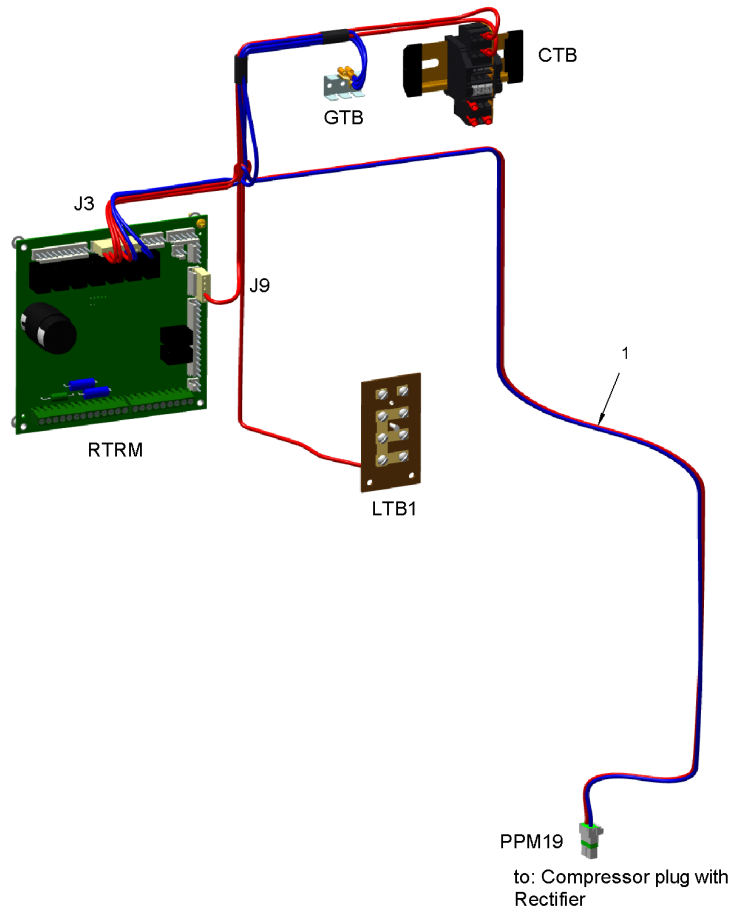

This is a typical illustration. The unit in the field may not appear exactly as shown.

Parts List Number :WSCUP10

Model Number :WSC102H4R0B00E0

Part No.	Reference No.	Quantity	Description
WIR09266	1	1	WIRE; HARNESS; C/D CAB, CNTLS, 2 STAGE COMP, BD IDM

TERMINAL BLOCK - CONTROLS (CTB)

75011855

REV.
A

This assembly is a component of the Common Controls Harness

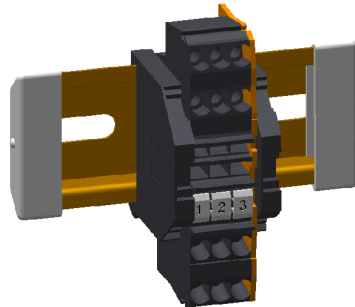

Reference - complete assembly

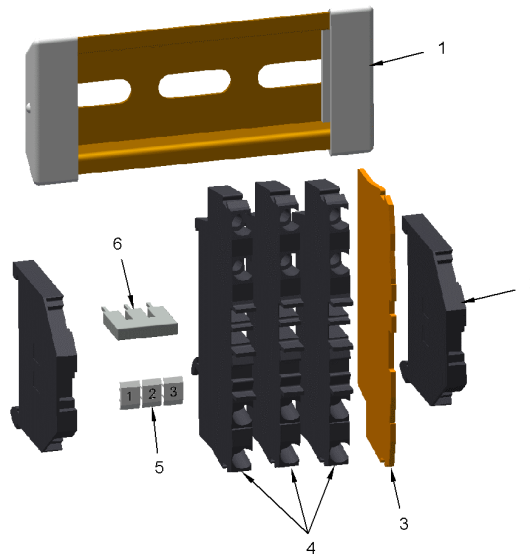

This is a typical illustration. The unit in the field may not appear exactly as shown.

Part No.	Reference No.	Quantity	Description
CAP01251	1	2	CAP; PROTECTIVE FORM CAP
TER01332	2	2	TERMINAL; BLOCK, END STOP
PLT04051	3	1	PLATE; 4 CONDUCTOR POLE END PLATE
TER01334	4	3	TERMINAL; BLOCK, 4 CONDUCTOR POLE 20A 600V
TER01351	5	1	TERMINAL; BLOCK, POLE MARKING 1-10 VERT
TER01354	6	1	TERMINAL; BLOCK, 3 POLE JUMPER

HARNESS - POWER

75012825

RP
A

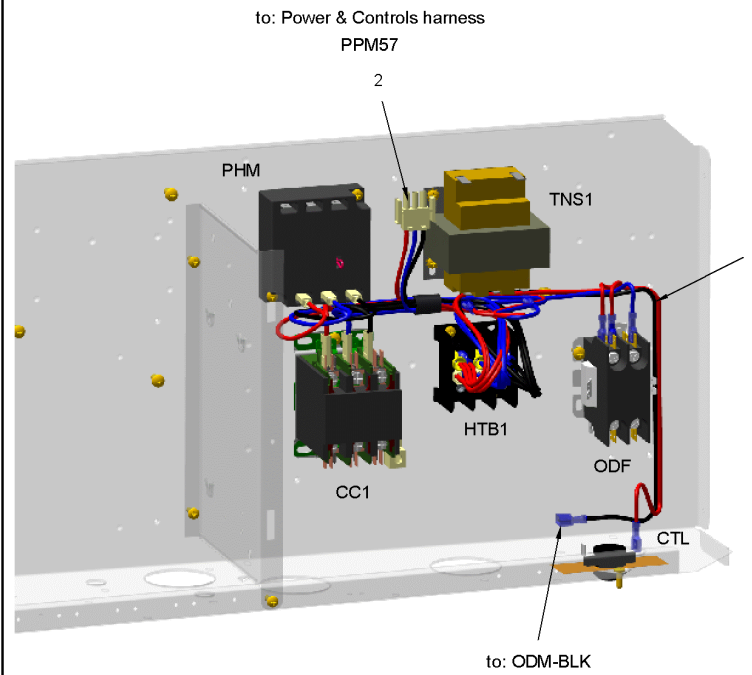

This is a typical illustration. The unit in the field may not appear exactly as shown.

Part No.	Reference No.	Quantity	Description
WIR09241	1	1	WIRE; HARNESS, POWER. CC1,ODF,ODM,PHM,TNS1,PPM57 TO HTB1 & CTL
CON00486	2	1	CONNECTOR; PLUG HOUSING, 3 PIN MALE

REFRIGERATION
COMPRESSOR, OUTDOOR COIL

75012786

RP
A

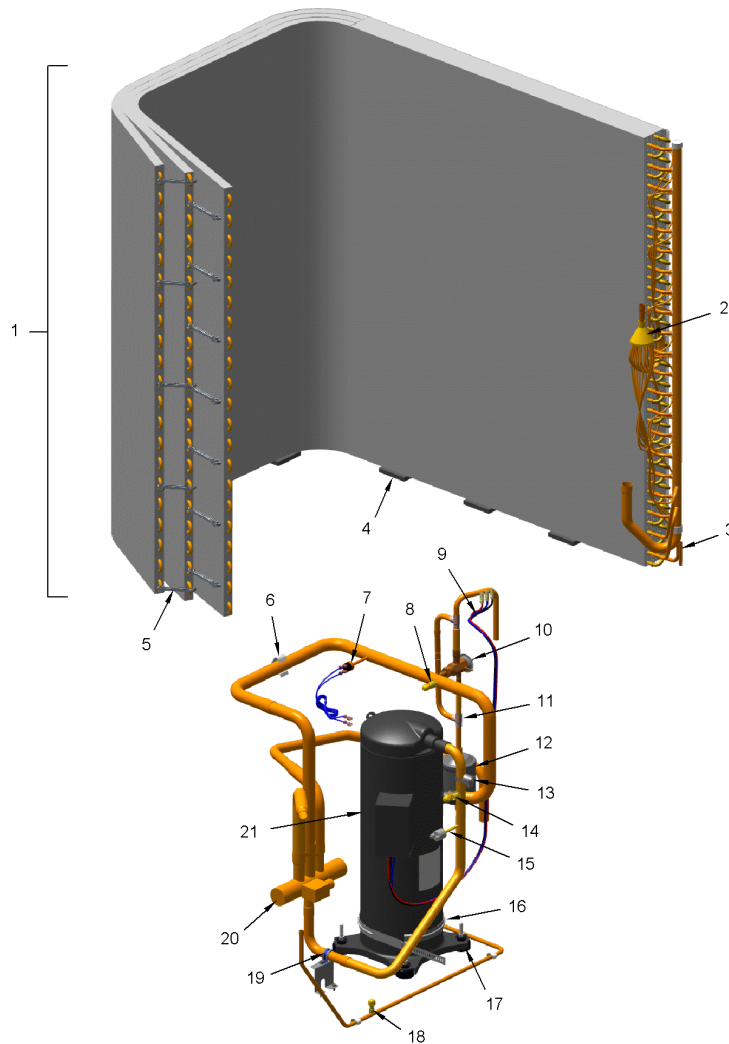

This is a typical illustration. The unit in the field may not appear exactly as shown.

Part No.	Reference No.	Quantity	Description
VAL02189	*	1	VALVE; CHECK, 1/2 ID INLET X 1/2 OD OUTLET, 4.6 IN LENGTH
HLD00255	3	1	HOLDER; THERMISTOR
INS01666	4	5	INSULATION; 0.40 X 3.00 X 3.00
KIT15254	5	12	KIT; OUTDOOR COIL CLIPS, BLACK PLASTIC, 3.878 LENGTH (PACKAGE OF 6 CLIPS)
CLP01073	6	1	CLIP; BULB (RED)
SWT03173	7	1	SWITCH; LOW PRESSURE CUTOFF, 250 OPEN, ACTUATION PRESSURE 41 +/- 4, RESET PRESSURE 25 +/- 4
WIR04406	7	1	WIRE; HARNESS, LOW PRESSURE SWITCH, 42 IN LENGTH, BLUE WIRES, CIR 1
CAP00072	8	1	CAP; VALVE, SEAL, .25 FFL
SET00819	8	1	SEAT; SADDLE MOUNT ASSEMBLY
STM00803	8	1	STEM; SADDLE MOUNT, VALVE CORE, BRASS, .344 DIA X 1.29 SCHRAEDER TYPE FITTING (TO INCLUDE 5 PIECES)
PLU01302	9	1	PLUG; COMPRESSOR; 2 STAGE SOLENOID WITH RECTIFIER, 2 PIN, 20 AWG, 10 IN LENGTH, (2 WIRE-RD,BL)
VAL18910	10	1	VALVE; EXPANSION_OD
TEE00143	11	2	MIN=50/50 TEE; 0.50C X 0.50C X 0.50C
DHY01467	12	1	DRIER; BI-FLOW; SERVICE FIRST; 16 CU. IN.; DCB164S, 1/2 ODF CONNECTIONS; 9.1 TON CAPACITY; MANUFACTURED FOR TRANE BY DANFOSS
THT02762	13	1	THERMOSTAT; WITH CLIP, .875 TUBE, 72" BLACK WIRES, SPST, 230F OPEN, 180F CLOSE
CAP00072	14	1	CAP; VALVE, SEAL, .25 FFL
SET00819	14	1	SEAT; SADDLE MOUNT ASSEMBLY
STM00803	14	1	STEM; SADDLE MOUNT, VALVE CORE, BRASS, .344 DIA X 1.29 SCHRAEDER TYPE FITTING (TO INCLUDE 5 PIECES)
SWT03398	15	1	SWITCH; HIGH PRESSURE, BRAZED, OPENS AT 650 PSIG, CLOSES AT 550 PSIG, 36 INCH WHITE LEADS
HTR03000	16	1	HEATER; CRANKCASE, 7.5 IN DIA, 70W, 460V, 48 IN LEADS
ISR00007	17	4	ISOLATOR; VIBRATION
NUT00355	17	4	NUT; HEX, LOCK, 5/16IN.-18
CAP00072	18	1	CAP; VALVE, SEAL, .25 FFL
COR00006	18	1	CORE; VALVE PORT, .79 LENGTH, .206-36 UNS 2A THD
VAL01483	18	1	VALVE; BODY, .44-20 THD X .25 ODS, STRAIGHT, BRASS, LESS CORE
CMP00109	19	1	CLAMP;
VAL18906	20	1	VALVE; REVERSING
COM12276	21	1	COMPRESSOR; SCROLL; TWO STAGE; COPELAND; ZPS91KCE-TFD-830; 91,000 BTUH; 8 TON; 460-60-3; R410-A

INDOOR COIL

75012811

RP
A

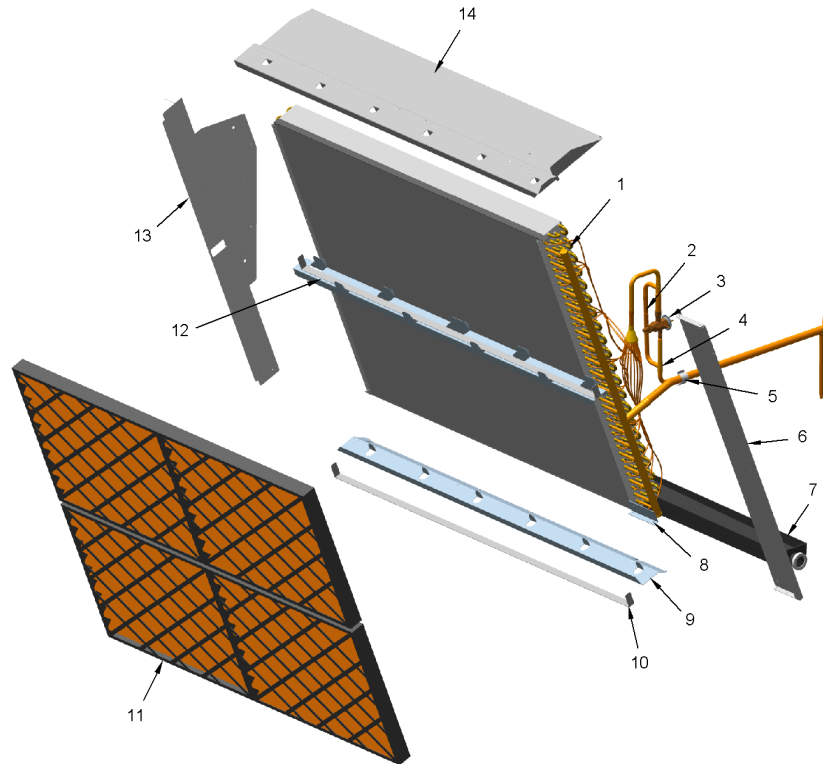

This is a typical illustration. The unit in the field may not appear exactly as shown.

Part No.	Reference No.	Quantity	Description
COL28427	1	1	COIL; INDOOR, FLAT FIN, 44.56 W X 40.00 H X 4 ROW
VAL02189	2	1	VALVE; CHECK, 1/2 ID INLET X 1/2 OD OUTLET, 4.6 IN LENGTH
VAL18911	3	1	VALVE; EXPANSION_ID
TEE00143	4	2	MIN=50/50 TEE; 0.50C X 0.50C X 0.50C
CLP01073	5	1	CLIP; BULB (RED)
BOF01684	6	1	BLOCKOFF; INDOOR COIL, FRONT, 40.6 X 5.5
BRK03234	8	1	BRACKET; INDOOR COIL, BOTTOM, 0.65 X 4.39 X 1.50
BOF02311	9	1	BLOCKOFF; INDOOR COIL BOTTOM, 51.44 X 2.65 X 2.15
TOL03963	10	1	TOOL; FILTER REMOVAL
BRK03938	12	1	BRACKET; FILTER CHANNEL, 50.50 LENGTH
TOL03963	12	1	TOOL; FILTER REMOVAL
BOF01685	13	1	BLOCKOFF, INDOOR COIL, REAR, 40 IN LENGTH

ECONOMIZER

75010609

REV.
A

TYPICAL ILLUSTRATION

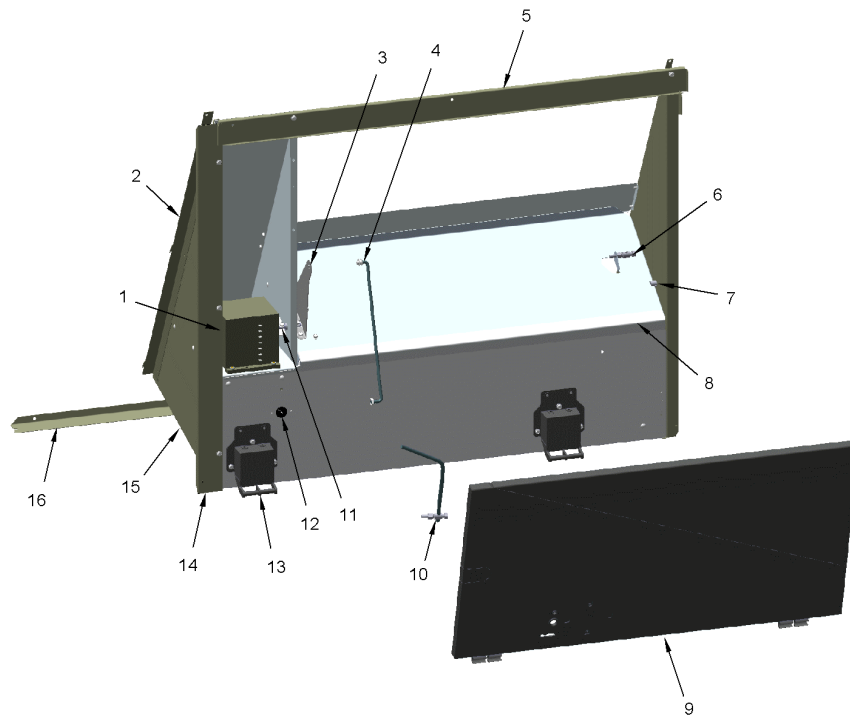

Part No.	Reference No.	Quantity	Description
BOF01669	*	1	BLOCKOFF; BAROMETRIC RELIEF (DUCT BLOCKOFF PLATE), 18.0 X 7.0
FLR04277	*	1	FILTER; MIST ELIMINATOR, 1.0 X 37.00 X 16.75
GRM00818	*	1	GROMMET; RUBBER .25 ID X .05 GRV MLD (1 CTN = 50 PCS)
KIT07669	*	1	KIT; SHIP WITH PARTS FOR ECONOMIZER (CONTAINS SCREWS, MIXED AIR SENSOR, GROMMET AND LITERATURE)
PLT03568	*	1	PLATE; BLADE STIFFENER, OUTSIDE AIR, 6.0 X 1.7
SCR00709	*	1	SCREW, 10-24 X .50
SCR00721	*	4	SCREW; PHILLIPS HEAD, 6-32 X 1/2
SEL00920	*	2	SEAL; DAMPER BLADE, 30.80 INCH LENGTH
SEN01036	*	1	SENSOR; HUMIDITY, 10-90 PRECENT RELATIVE HUMIDITY, 32-125F AMBIENT
SEN01036	*	1	SENSOR; HUMIDITY, 10-90 PRECENT RELATIVE HUMIDITY, 32-125F AMBIENT
SEN01829	*	1	SENSOR; THERMISTOR PROBE, -40 TO 65C, .25 DIA X 1.75 LG W/26" PVC LEADS-INSUL QC
WIR03346	*	1	WIRE; HARNESS, RETURN TEMP AND HUMIDITY (REFERENCE ENTHALPY CONTROL), 20 IN LENGTH, 156A-RED,157A-VIO
MOD01301	1	1	MODULE; ACTUATOR, FOOT MOUNTED, W/ CAPTIVE SCREWS, 2-10 VDC INPUT, SPRING RETURN ON POWER FAILURE (MOTOR ONLY)
MOD02618	1	1	MODULE; RELIATEL ECONOMIZER LOGIC, RTEM, RELIATEL
MNT02192	2	1	MOUNT; ADAPTER, ECONOMIZER, 33.2 X 1.2
ANG01291	3	1	ANGLE; OUTSIDE AIR LINKAGE CONNECTION, 6.6 X 4.5
BRG00653	4	1	BEARING, INSERT, DAMPER, .260 BORE
NUT00920	4	1	NUT; 0.25- PUSH ON SPRING STEEL
ROD00667	4	1	ROD; LINKAGE, .25 DIA X 11.50
BOF01616	5	1	BLOCKOFF; LOWER ECONOMIZER, 40.19 X 2.09
BRG00125	6	1	BEARING; LINKAGE, .25/.31 BALL JOINT, .25-.28 X .562
BRG00300	7	1	BEARING; LINKAGE, PIVOT, FEMALE NYLON, .50 OD X .50 LG
BLD01012	8	1	BLADE; ECONOMIZER DAMPER, 30.80 X 11.00
BLD01048	9	1	BLADE; RETURN AIR ECONOMIZER, PLASTIC, 32.70 X 17.70
BRG00125	10	1	BEARING; LINKAGE, .25/.31 BALL JOINT, .25-.28 X .562
ROD01129	10	1	ROD; HORIZONTAL LINKAGE CONN - .31 DIA X 5.50
ANG01543	11	1	ANGLE; ACTUATOR TO DRIVE ROD, 1.83 X 0.83 X 0.75
BRG00271	11	1	BEARING; DAMPER, MOLDED, .45 ID X .31 LG
ROD00619	11	1	ROD; STEEL, .44 DIA X 1.94 LG, ZINC OR CAD PLATED
BUS00309	12	1	BUSHING;SNAP, .88 MTG W/MAX .56 ID
BRK03550	13	2	BRACKET; MOUNTING, RETURN AIR BLADE
BRK03141	14	1	BRACKET; ECONOMIZER FILLER, 31.69 X 2.10
CBT01492	15	1	CABINET; ECONOMIZER/DAMPER
BRK03140	16	1	BRACKET; FILTER, OUTSIDE AIR, 37.93 X 1.44

Part No.	Reference No.	Quantity	Description
ASYSTAT712B	*	1	SENSOR; CO2 SENSING KIT; WALL MOUNTED (ASYSTAT712B)
ASYSTAT714B	*	1	SENSOR; CO2 SENSING KIT; DUCT MOUNTED (ASYSTAT714B)
BAYABRD001C	*	1	KIT; ACCESSORY, OPTIONS BOARD (BAYABRD001CA)
BAYBARM011A	*	1	DAMPER; BAROMETRIC RELIEF (BAYBARM011AB)
BAYBCIR001A	*	1	KIT; FIELD INSTALLED BCI (BAYBCIR001A)
BAYCO2K101A	*	1	KIT; WALL MOUNT CO2 SENSOR KIT
BAYCO2K103A	*	1	KIT;DUCT MOUNT CO2 SENSOR KIT
BAYCURB043A	*	1	CURB; ROOFCURB (BAYCURB043AB)
BAYDFPS004A	*	1	KIT; FAN FAILURE SWITCH (BAYDFPS004AB). (OPTIONS BOARD KIT09433-BAYABRD001CA MUST BE INSTALLED IN THE UNIT FOR THIS ACCESSORY TO OPERATE).
BAYDMPR054A	*	1	DAMPER; RELIATEL, 0-50 PERCENT MOTORIZED OUTSIDE AIR DAMPER (BAYDMPR054A)
BAYDMPR056B	*	1	DAMPER; 0-50% MANUAL OUTSIDE AIR DAMPER (BAYDMPR056BA)
BAYECON087A	*	1	ECONOMIZER; RELIATEL, 0-100 PERCENT DRY BULB (BAYECON087A)
BAYECON0704A	*	1	NO DESCRIPTION AVAILABLE
BAYENTH005A	*	1	KIT; REFERENCE ENTHALPY (BAYENTH005A)
BAYENTH006B	*	1	KIT; COMPARATIVE ENTHALPY (BAYENTH006B)
BAYFRST003A	*	1	KIT; HIGH TEMPERATURE SENSOR (BAYFRST003A)
BAYHAKT010E	*	1	KIT; ACCESSORY, HIGH ALTITUDE
BAYHSMT400A	*	1	OVERSIZED MOTOR KIT; 3 HP OS MOTOR, 208-230/460/60/3
BAYHTRU409A	*	1	ELECTRIC HEATER; 460-480/60/3, 9KW
BAYHTRU418A	*	1	ELECTRIC HEATER; 460-480/60/3, 18KW
BAYHTRU427A	*	1	ELECTRIC HEATER; 460-480/60/3, 9/18KW
BAYHTRU436A	*	1	ELECTRIC HEATER; 460-480/60/3, 36KW
BAYICSI003A	*	1	BOARD; ACCESSORY, RELIATEL COMMUNICATIONS INTERFACE BOARD (BAYICSI003AD)
BAYLMSW001A	*	1	POWER EXHAUST LIMIT SWITCH
BAYLOAM020B	*	1	CONTROL; EVAPORATOR DEFROST KIT (FROSTAT) (BAYLOAM020BB). (OPTIONS BOARD KIT09433-BAYABRD001CA MUST BE INSTALLED IN THE UNIT FOR THIS ACCESSORY TO OPE
BAYLTCI002B	*	1	KIT; RELIATEL COMMUNICATIONS INTERFACE THAT INCORPORATES LONTALK PROTOCOL (BAYLTCI002BB)
BAYPWRX027A	*	1	KIT; POWER EXHAUST, 460V (BAYPWRX027A)
BAYQACB011A	*	1	CURB; ADAPTA CURB (BAYQACB011AA), TRANSITIONS BAYCURB022B, 83.50 X 49.375
BAYQACB012A	*	1	CURB; ADAPTA CURB (BAYQACB012AA), TRANSITIONS BAYCURB025B, 90.50 X 60.625
BAYQACB013A	*	1	CURB; ADAPTA CURB (BAYQACB013AA), TRANSITIONS BAYCURB026B, 103.375 X 68.125
BAYRTEM001A	*	1	RELIATEL ECONOMIZER LOGIC MODULE
BAYSSENS050A	*	1	WIRELESS ZONE SENSOR
BAYTUBE007A	*	1	KIT; DISCHARGE AIR SENSING (BAYTUBE007A). (OPTIONS BOARD KIT09433-BAYABRD001CA MUST BE INSTALLED IN THE UNIT FOR THIS ACCESSORY TO OPERATE).
BAYVNOR001B	*	1	KIT; VENTILATION OVERRIDE (BAYVNOR001BB) (OPTIONS BOARD KIT09433-BAYABRD001CA MUST BE INSTALLED IN THE UNIT FOR THIS ACCESSORY TO OPERATE).
PLT04561	*	1	PLATE; WALL COVER PLATE ASSEMBLY (BAYMTP110A)
SEN00278	*	1	SENSOR; THERMISTOR PROBE, -40 DEG C TO 65 DEG, STRIPPED LEADS (BAYSSENS016AA)
SEN01447	*	1	SENSOR; ZONE, ROOM SENSOR W/TEMP. ADJUSTMENT WITH OVERRIDE AND CANCEL BUTTONS, 10K, DIAL, OCCUPIED (BAYSSENS074AA)
SEN01448	*	1	SENSOR; ZONE, REMOTE ROOM SENSOR, 10K (BAYSSENS077AA)
SEN01450	*	1	SENSOR; ZONE, ROOM SENSOR W/ OVERRIDE AND CANCEL BUTTONS, 10K, OCCUPIED (BAYSSENS073AA)
SEN01577	*	1	SENSOR; PROGRAMMABLE ZONE, AUTOMATIC OR MANUAL CHANGEOVER W/ SYSTEM LIGHTS TRANE (BAYSSENS119AA)
TOL00099	*	1	TOOL; RESISTANCE DECADE BOX

<p>MODEL NUMBER DESCRIPTION 75012766</p> <p>DX Cooling / DX Cooling, Gas Heat / Pkg Heat Pump</p>		<p>RP A</p>
<p><i>Example Model Number:</i></p> <p>YSC092H3RZA00C6C2A1A000DEA11A0D1</p> <p>1 - - - - 5 - - - - 10 - - - - 15 - - - - 20 - - - - 25 - - - - 30 - - - -</p>		
<p>Digit 1 – Unit Type D = Dual Fuel Heat Pump T = DX Cooling W = Packaged Heat Pump Y = DX Cooling, Gas Heat</p> <p>Digit 2 – Efficiency S = Standard Efficiency H = High Efficiency</p> <p>Digit 3 – Airflow C = Convertible</p> <p>Digits 4,5,6 – Nominal Gross Cooling Capacity (MBh) 072 = 6 Ton 074 = 6 Ton 090 = 7.5 Ton 092 = 7.5 Ton 102 = 8.5 Ton 120 = 10 Ton</p> <p>Digit 7 – Major Design Sequence H = Major Design Sequence</p> <p>Digit 8 – Voltage Selection 3 = 208-230/60/3 4 = 460/60/3 W = 575/60/3</p> <p>Digit 9 – Unit Controls E = Electromechanical R = ReliaTel™ Microprocessor</p> <p>Digit 10 – Heating Capacity <i>Note: Applicable to Digit 1, T or W models only</i> 0 = No Electric Heat C = 9 kW G = 18 kW K = 27 kW N = 36 kW P = 54 kW <i>Note: Applicable to Digit 1, D or Y models only</i> L = Low Heat M = Medium Heat H = High Heat X = Low Heat, Stainless Steel Heat Exchanger Y = Medium Heat, Stainless Steel Heat Exchanger Z = High Heat, Stainless Steel Heat Exchanger</p>	<p>Digit 11 – Minor Design Sequence A = First Sequence</p> <p>Digits 12, 13 – Service Sequence ** = Factory Assigned</p> <p>Digit 14 – Fresh Air Selection 0 = No Fresh Air A = Manual Outside Air Damper 0-50% B = Motorized Outside Air Damper 0-50% C = Economizer, Dry Bulb 0-100% without Barometric Relief D = Economizer, Dry Bulb 0-100% with Barometric Relief E = Economizer, Reference Enthalpy 0-100% without Barometric Relief F = Economizer, Reference Enthalpy 0-100% with Barometric Relief G = Economizer, Comparative Enthalpy 0-100% without Barometric Relief H = Economizer, Comparative Enthalpy 0-100% with Barometric Relief K = Low Leak Economizer with Barometric Relief M = Low Leak Economizer with Reference Enthalpy with Barometric Relief P = Low Leak Economizer with Comparative Enthalpy with Barometric Relief</p> <p>Digits 15 – Supply Fan/Drive Type/Motor 0 = Standard Drive 1 = Oversized Motor 6 = Single Zone VAV 7 = Multi-Speed Indoor Fan E = Multi-Zone Variable Air Volume</p> <p>Digit 16 – Hinged Service Access/Filters 0 = Standard Panels/Standard Filters A = Hinged Access Panels/Standard Filters B = Standard Panels/2" MERV 8 Filters C = Hinged Access Panels/2" MERV 8 Filters D = Standard Panels/2" MERV 13 Filters E = Hinged Access Panels/2" MERV 13 Filters</p>	
		<p>1 of 2</p>

MODEL NUMBER DESCRIPTION	75012767	RP A
DX Cooling / DX Cooling, Gas Heat / Pkg Heat Pump		
<p><i>Example Model Number:</i></p> <p>YSC092H3RZA00C6C2A1A000DEA11AD1</p> <p style="font-size: small; text-align: center;">1 - - - - 5 - - - - 10 - - - - 15 - - - - 20 - - - - 25 - - - - 30 - - - -</p>		
<p>Digit 17 – Condenser Coil Protection 0 = Standard Coil 1 = Standard Coil with Hail Guard 2 = Black Epoxy Condenser Coil Guard 3 = Black Epoxy Condenser Coil with Hail Guard 4 = CompleteCoat Condenser Coil 5 = CompleteCoat Condenser Coil with Hail Guard</p> <p>Digit 18 – Through the Base Option 0 = No Through-the-Base Provisions A = Through-the-Base Electric B = Through-the-Base Gas Piping C = Through-the-Base Electric and Gas Piping</p> <p>Digit 19 – Disconnect/Circuit Breaker 0 = No Disconnect/No Circuit Breaker 1 = Unit Mounted Non-Fused Disconnect 2 = Unit Mounted Circuit Breaker</p> <p>Digit 20 – Convenience Outlet 0 = Convenience Outlet A = Unpowered Convenience Outlet B = Powered Convenience Outlet</p> <p>Digit 21 – Communications Options 0 = No Communications Interface 1 = Trane® Communications Interface 2 = LonTalk® Communications Interface 6 = BACnet® Communications Interface 7 = Air-Fi™ Wireless Communications Interface</p> <p>Digit 22 – Refrigeration System Option 0 = Standard Refrigeration System</p> <p>Digit 23 – Refrigeration Controls 0 = Without Refrigeration Controls 1 = Frostat™</p> <p>Digit 24 – Smoke Detector 0 = No Smoke Detector A = Return Air Smoke Detector B = Supply Air Smoke Detector C = Supply and Return Air Smoke Detectors D = Plenum Smoke Detector</p>	<p>Digit 25 – System Monitoring Controls 0 = Standard Monitoring System 1 = Clogged Filter Switch 2 = Fan Failure Switch 3 = Discharge Air Sensing Tube 4 = Clogged Filter Switch and Fan Failure Switch 5 = Clogged Filter Switch and Discharge Air Sensing Tube 6 = Fan Failure Switch and Discharge Air Sensing Tube 7 = Clogged Filter Switch, Fan Failure Switch and Discharge Air Sensing Tube A = Condensate Drain Pan Overflow Switch B = Clogged Filter Switch and Condensate Drain Pan Overflow Switch C = Fan Failure Switch and Condensate Drain Pan Overflow Switch D = Discharge Air Sensing Tube and Condensate Drain Pan Overflow Switch E = Clogged Filter Switch, Fan Failure Switch and Condensate Drain Pan Overflow Switch F = Clogged Filter Switch, Discharge Air Sensing Tube and Condensate Drain Pan Overflow Switch G = Fan Failure Switch, Discharge Air Sensing Tube and Condensate Drain Pan Overflow Switch F = Clogged Filter Switch, Fan Failure Switch, Discharge Air Sensing Tube and Condensate Drain Pan Overflow Switch</p> <p>Digit 26 – System Monitoring Controls 0 = No Monitoring Controls A = Demand Control Ventilation (CO₂) B = Low Leak Economizer with FDD (Fault Detection & Diagnostics) C = FDD (Fault Detection & Diagnostics) with DCV (Demand Control Ventilation)</p> <p>Digits 27 – Unit Hardware Enhancements 0 = No Enhancements 1 = Stainless Steel Drain Pan</p> <p>Digit 31 – Advanced Unit Controls 0 = Standard Unit Controls 1 = Human Interface</p>	
2 of 2		

