

Submittal Package

Viega ProPress® Stainless

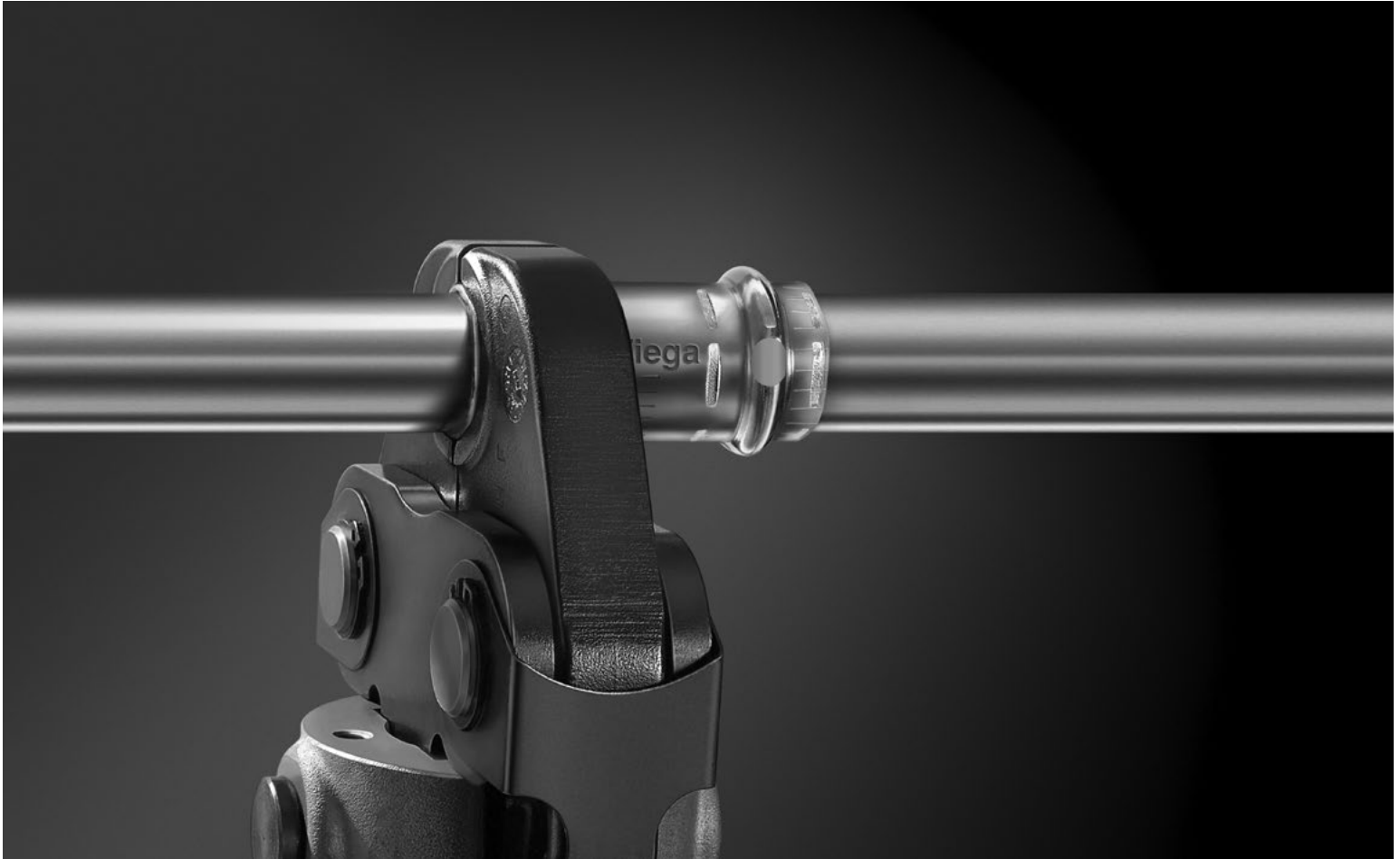

Project _____ **Date** _____

Engineer _____ **Contractor** _____

Submitted by _____

Approved by _____ **Date** _____ **Approved by** _____ **Date** _____

Table of Contents

Chilled Water
 Hydronic Heating
 Fire Protection
 Low-Pressure Steam
 Compressed Air
 Industrial Gases
 Vacuum

1	System Data Sheet _____	3
	ProPress 304 FKM _____	3
	ProPress 316 _____	4
2	Product Instructions _____	5
	ProPress Stainless ½" to 2" Fittings _____	5
	ProPress Stainless 2½" to 4" Fittings _____	6
3	Engineering Specifications _____	7
	ProPress Stainless _____	7
4	Dimensional Documents _____	11
	ProPress Stainless Fittings _____	11
5	Limited Warranty _____	22
	Viega ProPress Fittings and Valves _____	22
	Viega Metal Systems for Industrial Applications _____	23
	Viega Marine Applications _____	24



ProPress 304 FKM ½" to 2" formerly ProPress Stainless 304.
 ProPress 304 FKM 2½" to 4" formerly ProPress Stainless 304 XL.
 ProPress 316 ½" to 2" formerly ProPress Stainless 316.
 ProPress 316 2½" to 4" ProPress Stainless 316 XL.



Viega products are designed to be installed by licensed and trained plumbing and mechanical professionals who are familiar with Viega products and their installation. **Installation by non-professionals may void Viega LLC's warranty.**



This document is subject to updates. For the most current Viega technical literature please visit www.viega.us.

1 System Data Sheet

ProPress 304 FKM



ProPress 304 FKM is a stainless steel system designed to be used with Viega stainless steel pipe to form a complete press system that is ideal for industrial applications. ProPress 304 FKM fittings utilize a versatile FKM sealing element to provide a permanent, leak-free connection in

dimensions from 1/2" to 4". A ProPress 304 FKM system can stand up to harsh environments while transporting process water, diesel fuel, lube oil, ammonia, low pressure steam, or any number of other essential fluids.

ProPress 304 FKM fittings are offered in configurations including: elbows, couplings, reducers, tees, reducing tees, threaded adapters, unions, caps, and flanges. ProPress 304 FKM fittings in 2 1/2" to 4" have a 420 stainless steel grip ring and a PBT separator ring in addition to the FKM sealing element.

Operating Parameters

- Operating Pressure: 200 psi maximum
- Test Pressure: 600 psi maximum
- Operating Temperature: 14°F to 284°F
(with temp. spikes up to 356°F)

Listings and Certificates

- ABS
- ASME B31.1, B31.3, B31.9
- ICC-ES LC1002
- NFPA 13, 13D, and 13R
- UL/ANSI 213
- UL/ANSI 852

International Listings and Certificates

- BV: Bureau Veritas
- CRN: 13492.5 A/B/C
- DNV GL: Det Norske Veritas Germanischer
- LR: Lloyd's Register
- NKK: Nippon Kaija Kyokai
- ULC/ANSI ORD-C213

Contact your local Viega representative for details on local approvals.

Compliant With

- ASME B31
- ASTM A312
- ASTM A554

Approved Applications

- Hydronic heating (with glycol)
- Chilled water
- Compressed air
- Fire sprinkler (175 psi maximum)
- Low pressure steam (15 psi maximum)
- Vacuum (29.2" Hg maximum @ 68°F)
- Acetylene
- Fuel oil
- Diesel fuel (125 psi)
- Lube oil

ProPress 304 FKM systems are approved for underground use. When installed underground, ProPress 304 FKM should have proper corrosion protection in accordance with local and national codes.

For more specific information on applications for ProPress 304 FKM fittings, contact Viega Technical Services at 1-800-976-9819.

Smart Connect® Technology

ProPress 304 FKM fittings are manufactured with Viega's unique Smart Connect technology. Designed into the fitting itself, Viega Smart Connect technology allows identification of an unpressed fitting during pressure testing.

System Data Sheet

ProPress 316



ProPress 316 is a stainless steel system designed to be used with Viega 316 stainless steel tubing to form a complete press system that is ideal for process water and durable enough to handle industrial applications or environments. ProPress 316 fittings feature the same

EPDM sealing element found in ProPress copper fittings and provide the same permanent leak-free connections in dimensions from 1/2" to 4".

ProPress 316 fittings are offered in configurations including: elbows, couplings, reducers, tees, reducing tees, threaded adapters, unions, caps, and flanges. ProPress 316 fittings in 2 1/2" to 4" have a 420 stainless steel grip ring and a PBT separator ring in addition to the EPDM sealing element.

Operating Parameters

- Operating Pressure: 200 psi maximum
- Test Pressure: 600 psi maximum
- Operating Temperature: 0°F to 250°F

Listings and Certificates

- ABS
- ASME B31.1, B31.3, B31.9
- IAPMO PS-117
- ICC-ES LC1002

International Listings and Certificates

- BV: Bureau Veritas
- DNV GL: Det Norske Veritas Germanischer
- LR: Lloyd's Register
- NKK: Nippon Kaija Kyokai

Contact your local Viega representative for details on local approvals.

Compliant With

- ASME B31
- ASTM A312
- ASTM A403
- ASTM A554
- IAPMO Uniform Mechanical Code (UMC)
- ICC International Mechanical Code (IMC)

Approved Applications

- Hydronic heating (with glycol)
- Chilled water
- Low pressure steam (15 psi maximum)
- Isopropyl alcohol
- Latex Paint
- Phosphoric acid
- Compressed Air
- Non-medical gases
- Vacuum (29.2" Hg maximum @ 68°F)

ProPress 316 systems are approved for underground use. When installed underground, ProPress 316 fittings should have proper corrosion protection in accordance with local and national codes.

For more specific information on applications for ProPress 316, contact Viega Technical Services at 1-800-976-9819.

Smart Connect® Technology

ProPress 316 fittings are manufactured with Viega's unique Smart Connect technology. Designed into the fitting itself, Viega Smart Connect technology allows identification of an unpressed fitting during pressure testing.

2 Product Instructions

ProPress Stainless 1/2" to 2" Fittings

For use only with Viega stainless steel tubing

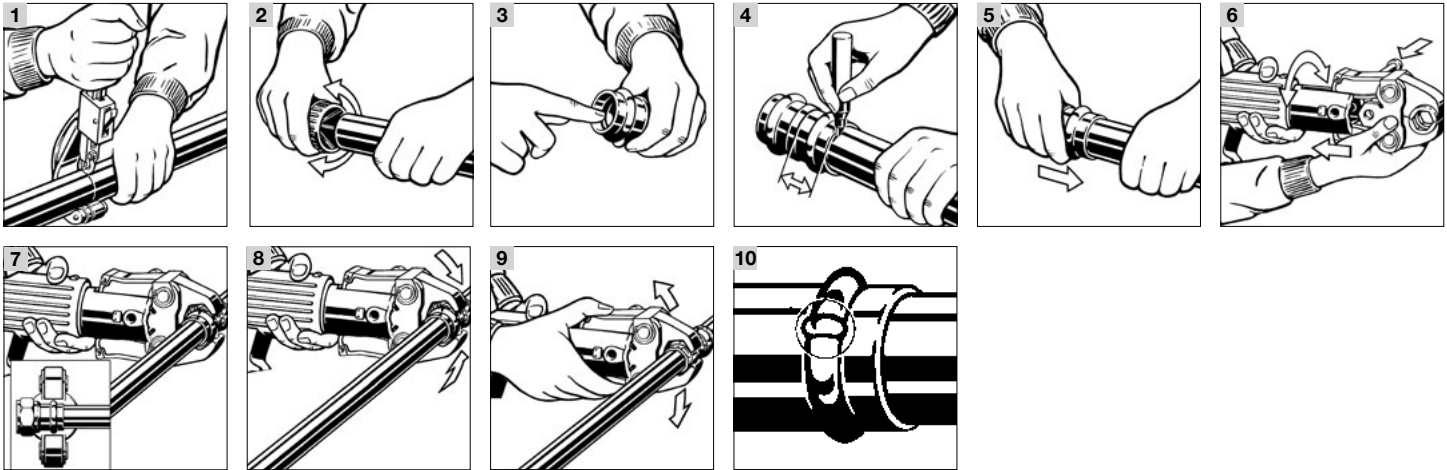

DANGER!
Read and understand all instructions for installing Viega ProPress Stainless fittings. Failure to follow all instructions may result in extensive property damage, serious injury, or death.

1 Cut stainless steel tubing only with an approved stainless steel pipe cutting tool. Cut the tube square using a displacement-type cutter or fine toothed saw.

i Cut tubing a minimum of four inches away from the contact area of the vise to prevent possible damage to the tubing in the press area.

2 Deburr inside and outside of the tube to the proper insertion depths to prevent cutting sealing element. Use a wire brush, Scotchbrite pad, sand cloth, or sandpaper to remove loose dirt and rust particles from the pressing area.

3 Check the sealing element for correct fit. Do not use oils or lubricants. Use only Viega sealing elements.

i For applications requiring a different sealing elements, remove the factory-installed sealing element and replace with the applicable sealing element. See [Changing Sealing Elements Product Instructions](#).

4 Mark the proper insertion depth as indicated by the Viega ProPress Stainless Insertion Depth Chart. Improper insertion depth may result in an improper seal.

Tube Size (in)	Insertion Depth (in)
1/2	3/4
3/4	7/8
1	7/8
1 1/4	1
1 1/2	1 1/16
2	1 9/16

5 While turning slightly, slide press fitting onto tubing to the marked depth. End of tubing must contact stop.

6 Insert appropriate Viega ProPress jaw into the press tool and push in, holding pin until it locks in place

Warning!
 Keep extremities and foreign objects away from press tool during pressing operation to prevent injury or incomplete press.

7 Open the jaw and place at right angle on the fitting. Visually check insertion depth using mark on tubing.

8 Hold trigger on press tool until press jaws have fully engaged the fitting. Jaws will automatically release after a full press is made.

9 After pressing, open the jaw and remove the press tool.

10 Pressure testing with Smart Connect®: Unpressed connections are located by pressurizing the system with air or water. When testing with water the proper pressure range is 15 psi to 85 psi. When testing with compressed air the proper pressure range is 1/2 psi to 45 psi maximum. If testing with compressed air, use an approved leak-detect solution. Following a successful pressure test, the system may be pressure tested up to 200 psi with air or up to 600 psi with water.

i Testing for unpressed connections using Smart Connect is not a replacement for pressure testing requirements of local codes and standards.

CAUTION!
 It is the responsibility of designers of piping systems to verify the suitability of type 304 and 316 stainless steel pipe for use with the intended fluid media. The fluid's chemical composition, pH level, operation temperature, chloride level, oxygen level, and flow rate and their effect on AISI type 304 or 316 stainless steel must be evaluated by the material specifier to confirm system life will be adequate for the intended service. Failure to do so may cause serious personal injury or property damage. Contact Viega Technical Services for questions and approvals.

Product Instructions

ProPress Stainless 2½" to 4" Fittings

For use only with Viega stainless steel tubing

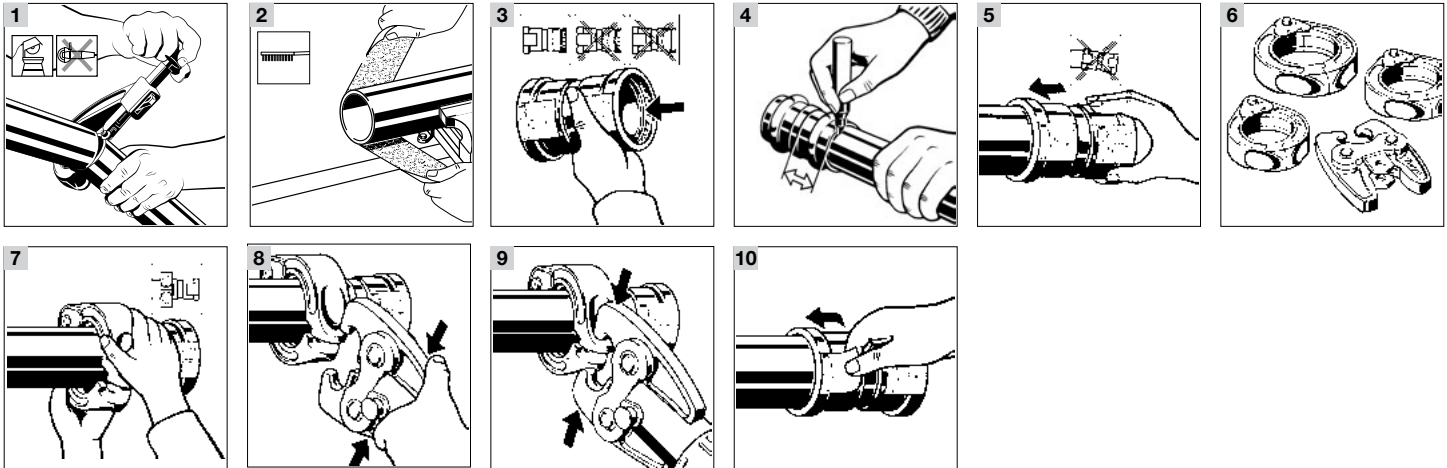

DANGER!
Read and understand all instructions for installing Viega ProPress Stainless fittings. Failure to follow all instructions may result in extensive property damage, serious injury, or death.

1 Cut stainless steel tubing only with an approved stainless steel pipe cutting tool. Cut the tube square using a displacement-type cutter or fine toothed saw.

i Cut tubing a minimum of four inches away from the contact area of the vise to prevent possible damage to the tubing in the press area.

2 Deburr inside and outside of the tube to the proper insertion depths to prevent cutting sealing element. Use a wire brush, Scotchbrite pad, sand cloth, or sandpaper to remove loose dirt and rust particles from the pressing area.

3 Check the sealing element, separator ring, and grip ring for correct fit. Do not use oils or lubricants. Use only Viega ProPress shiny black EPDM for 316 or dull black FKM for 304 sealing elements.

4 Mark the proper insertion depth as indicated by the Viega ProPress Stainless XL Insertion Depth Chart. Improper insertion depth may result in an improper seal.

Insertion Depth (in)	d (in)
2½	1 11/16
3	1 5/16
4	2%

- 5** While turning slightly, slide press fitting onto tubing to the marked depth. End of tubing must contact stop.
- 6** Press Viega ProPress Stainless XL fittings with Viega ProPress XL-C rings and V2 ACTUATOR.

! **Use only rings that are compatible with ProPress XL-C fittings.** Do not use rings intended for 2½" to 4" Bronze fittings.

- 7** Open XL-C ring and place at right angles on the fitting. Ensure that the XL-C ring is engaged on the fitting bead.
- 8** With V2 actuator inserted into the press tool, open the V2 actuator. Connect the V2 actuator to the XL-C ring. Look at insertion depth mark on the tube to make sure that the tube is properly inserted into the fitting.

Warning!
 Keep extremities and foreign objects away from press tool during pressing operation to prevent injury or incomplete press.

- 9** Hold the trigger until the actuator has engaged the XL-C ring.
- 10** Upon completion of the press, release the V2 actuator from XL-C ring. Remove the XL-C ring from fitting. Remove product instruction label from fitting to indicate that press has been completed.

Pressure testing with Smart Connect®

Unpressed connections are located by pressurizing the system with air or water. When testing with water the proper pressure range is 15 psi to 85 psi. When testing with compressed air the proper pressure range is ½ psi to 45 psi maximum. If testing with compressed air, use an approved leak-detect solution. Following a successful pressure test, the system may be pressure tested up to 200 psi with air or up to 600 psi with water.

i Testing for unpressed connections using Smart Connect is not a replacement for pressure testing requirements of local codes and standards.

CAUTION!
 It is the responsibility of designers of piping systems to verify the suitability of type 304 and 316 stainless steel pipe for use with the intended fluid media. The fluid's chemical composition, pH level, operation temperature, chloride level, oxygen level, and flow rate and their effect on AISI type 304 or 316 stainless steel must be evaluated by the material specifier to confirm system life will be adequate for the intended service. Failure to do so may cause serious personal injury or property damage. Contact Viega Technical Services for questions and approvals.

3 Engineering Specifications

ProPress Stainless

Part 1: General

1.1 Summary

Stainless steel pipe and fitting system using cold press connection technology. The system is assembled when the pipe is fully inserted into the fitting, then pressed on both sides of the fitting seal, creating a mechanical joint.

1.2 Definitions

ASME: American Society of Mechanical Engineers

ASTM: American Society for Testing and Materials

AWWA: American Water Works Association

EPDM: Ethylene Propylene Diene Monomer

FKM: Fluoroelastomer

IAPMO: International Association of Plumbing & Mechanical Officials

ICC: International Code Council

MSS: Manufacturers Standardization Society

NFPA: National Fire Protection Association

NSF: National Sanitation Foundation

1.3 References

ASME A13.1: Scheme for the Identification of Piping Systems

ASME B1.20 Pipe Threads, General Purpose (Inch)

ASME B31.1 Power Piping

ASME B31.3 Process Piping

ASME B31.9 Building Services Piping

ASTM A312 Standard Specification for Seamless, Welded, and Heavily Cold Worked Austenitic Stainless Steel Pipes

ASTM A554 Standard Specification For Welded Stainless Steel Mechanical Tubing

AWWA C651 Standard for Disinfecting Water Mains

IAPMO Uniform Mechanical Code

IAPMO Uniform Plumbing Code

ICC International Plumbing Code

ICC International Mechanical Code

MSS-SP-58 Pipe Hangers and Supports - Materials, Design and Manufacture

NFPA 13 Standard for the Installation of Sprinkler Systems (Approval Pending)

NFPA 13D Standard for the Installation of Sprinkler Systems in One- and Two-family Dwellings and Manufactured Homes (Approval Pending)

NFPA 13R Standard for the Installation of Sprinkler Systems in Residential Occupancies Up to and Including Four Stories in Height (Approval Pending)

NSF 61 Drinking Water System Components – Health Effects

1.4 Quality Assurance

A. Installer shall be a qualified installer, licensed within the jurisdiction, and familiar with the installation of stainless steel pipe.

B. The installation of stainless steel pipe for hot and cold water distribution systems shall conform to the requirements of the ICC International Plumbing Code or IAPMO Uniform Plumbing Code. The installation of stainless steel pipe in hydronic systems shall conform to the requirements of the ICC International Mechanical Code or the IAPMO Uniform Mechanical Code.

1.5 Delivery, Storage, and Handling

- A. Stainless steel pipe shall be shipped to the job site on truck or in such a manner to protect the pipe. The pipe and fittings shall not be roughly handled during shipment. The pipe and fittings shall be unloaded with reasonable care.
- B. Protect the stored pipe from moisture and dirt. Elevate above grade. When stored inside, do not exceed the structural capacity of the floor.
- C. Protect fittings and piping from moisture and dirt.

1.6 Project Conditions

Verify length of pipe required by field measurements.

1.7 Warranty

- A. The pipe and fittings manufacturer shall warrant that the pipe and fittings are free from defects and conform to the designated standard. The warranty shall only be applicable to pipe and fittings installed in accordance with the manufacturer's installation instructions.
- B. The manufacturer of the pipe and fittings shall not be responsible for the improper use, handling, or installation of the product.

Part 2: Products

2.1 Manufactures

Viega LLC
585 Interlocken Blvd.
Broomfield CO, 80021
Phone: (800) 976-9819
www.viega.us

2.2 Material

- A. Pipe standard: stainless steel pipe shall conform to ASTM A312 or ASTM A554.
- B. Fitting standard: stainless steel fittings shall conform to the material requirements of ASTM A312 or ASTM A554.
- C. Press fitting: stainless steel press fittings shall conform to the material and sizing requirements of ASME A312 or ASTM A554. O-rings for stainless steel press fittings shall be EPDM or FKM, depending on the application.
- D. Threaded fittings: pipe threads shall conform to ASME B1.20.1.
- E. Hanger standard: hangers and supports shall conform to MSS-SP-58.

2.3 Source Quality Control

All pipe, fittings, and joining materials in contact with drinking water shall be listed by a third party agency to NSF 61.

Part 3: Execution

3.1 Examination

The installing contractor shall examine the stainless steel pipe and fittings for defects and cracks. There shall be no defects of the pipe or fittings. Any damaged pipe or fittings shall be rejected.

3.2 Preparation

- A. Stainless steel pipe shall be cut with a wheeled pipe cutter or approved stainless steel pipe cutting tool. The pipe shall be cut square to permit proper joining with the fittings.
- B. Remove scale, slag, dirt, and debris from inside and outside of pipe and fittings before assembly. The pipe end shall be wiped clean and dry. The burrs on the pipe shall be reamed with a deburring or reaming tool.

3.3 Installation General Locations

Plans indicate general location and arrangement of piping systems. Identified locations and arrangements are used to size pipe and calculate friction loss, expansion, pump sizing, and other design considerations. Install piping as indicated, except where deviations to layout are approved on coordination drawings.

3.4 Installation

- A. Pressure rating: install components having a pressure rating equal to or greater than the system operating pressure.
- B. Install piping free of sags, bends, and kinks.
- C. Change in direction: install fittings for changes in direction and branch connections.
- D. Press connections: stainless steel press fittings shall be made in accordance with the manufacturer’s installation instructions. The pipe shall be fully inserted into the fitting and the pipe marked at the shoulder of the fitting. The fitting alignment shall be checked against the mark on the pipe to assure the pipe is fully engaged (inserted) in the fitting. The joints shall be pressed using the tool approved by the manufacturer.
- E. Threaded joints: threaded joints shall have pipe joint compound or teflon tape applied to the male threads only. Tighten joint with a wrench and backup wrench as required.
- F. Pipe protection: provide protection against abrasion where stainless steel pipe is in contact with other building members by wrapping with an approved tape, pipe insulation, or otherwise suitable method of isolation.
- G. Penetration protection: provide allowance for thermal expansion and contraction of stainless steel pipe passing through a wall, floor, ceiling, or partition by wrapping with an approved tape or pipe insulation or by installing through an appropriately sized sleeve. Penetrations for fire resistant rated assemblies shall maintain the rating of the assembly.
- H. Backfill material: backfill material shall not include any ashes, cinders, refuse, stones, boulders, or other materials which can damage or break the pipe or promote corrosive action in any trench or excavation in which pipe is installed.
- I. Horizontal support: install hangers for horizontal piping in accordance with local code or the following maximum spacing and minimum rod sizes.

Nominal Pipe Size (in)	Stainless Steel Pipe Max. Span (ft)	Min. Rod Diameter (in)
Up to ¾	10	¾
1	10	¾
1¼	10	¾
1½	10	¾
2	10	¾
2½	11	1½
3	12	1½
4	14	5/8

All systems must be installed per local codes and/or standards and requirements. Consult the Viega technical support department before installing the system in other applications or applications with temperatures and/or pressures outside the stated ratings. Refer to Viega’s Application Guide for more information.

- J. Vertical support: vertical stainless steel pipe shall be supported at each floor or at 10 foot intervals.
- K. Galvanic corrosion: hangers and supports shall be either stainless steel or vinyl coated to prevent galvanic corrosion between the pipe and the supporting member.
- L. Restraint: in seismic areas, stainless steel pipe shall be installed to withstand all seismic forces.
- M. Identification: stainless steel pipe systems shall be identified in accordance with the requirements of ASME A13.1.

3.5 Field Quality Control

- A. Viega ProPress Stainless includes Smart Connect® technology, a quick and easy way of identifying unpressed connections during the pressure testing process. This indentation is removed during the pressing process, creating a leak-free, permanent connection. Smart Connect technology provides identification of connections which have not been pressed prior to putting the system in to operation. Smart Connect technology may be pressure tested with air or water.
- When testing with air, the pressure range is ½ psi to 45 psi maximum.
 - When testing with water, the pressure range is 15 psi to 85 psi maximum.
- B. The Smart Connect technology pressure test is not a substitute for local code required pressure testing of the piping system. Carry out the final piping system pressure test in accordance with local codes.

3.6 Cleaning (Potable Water Systems)

- A. Disinfection: the stainless steel hot and cold water distribution system shall be disinfected prior to being placed in service. The system shall be disinfected in accordance with AWWA C651 or the following requirements:
1. The piping system shall be flushed with potable water until discolored water does not appear at any of the outlets.
 2. The system shall be filled with a water chlorine solution containing between 50 and 200 parts per million of chlorine. The system shall be valved in the closed position and allowed to stand for 24 hours.
 3. Following the standing time, the system shall be flushed with water until the chlorine is purged from the system.

4 Dimensional Documents

ProPress Stainless Fittings

ProPress Stainless Pipe ASTM A312 - Models 0103 / 4003

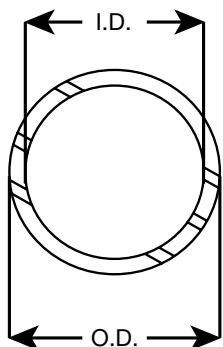

Part No.		Size (in)	O.D. (in)	I.D. (in)	Wall Thickness (in)	Length (ft)
304	316					
87000	82000	½	0.63	0.50	0.06	20
87005	82005	¾	0.88	0.75	0.06	20
87010	82010	1	1.13	1.00	0.06	20
87015	82015	1¼	1.38	1.26	0.06	20
87020	82020	1½	1.63	1.50	0.06	20
87025	82025	2	2.13	2.00	0.06	20

ProPress Stainless Pipe ASTM A312 - Models 0107XL / 4007XL

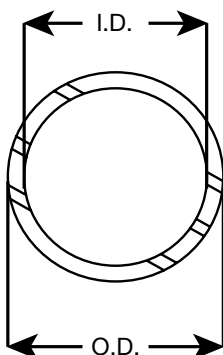

Part No.		Size (in)	O.D. (in)	I.D. (in)	Wall Thickness (in)	Length (ft)
304	316					
87095	82042	2½	2.63	2.47	0.08	20
87100	82050	3	3.13	2.97	0.08	20
87105	82055	4	4.13	3.97	0.08	20

ProPress 304 ECO Pipe ASTM A554 - Model 0108

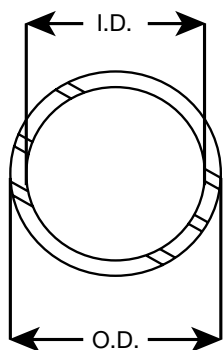

Part No.	Size (in)	O.D. (in)	I.D. (in)	Wall Thickness (in)	Length (ft)
304					
87050	½	0.63	0.55	0.04	20
87055	¾	0.88	0.78	0.05	20
87060	1	1.13	1.03	0.05	20
87065	1¼	1.38	1.26	0.06	20
87070	1½	1.63	1.51	0.06	20

ProPress 304 ECO Pipe ASTM A554 - Model 0108XL

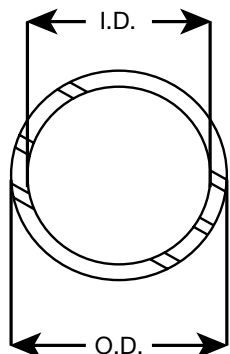

Part No.	Size (in)	O.D. (in)	I.D. (in)	Wall Thickness (in)	Length (ft)
304					
87080	2½	2.63	2.47	0.08	20
87085	3	3.13	2.97	0.08	20
87090	4	4.13	3.97	0.08	20

ProPress Stainless 90° Elbow P x P - Models 6016 / 4016

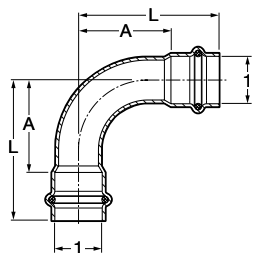

Part No.	Size (in)	A (in)	L (in)
304	316	1	
85402	80400	½	1.87
85407	80405	¾	2.64
85412	80410	1	2.78
85417	80415	1¼	2.69
85422	80420	1½	3.41
85427	80425	2	4.14

ProPress Stainless 90° Elbow P x P - Models 6016XL / 4016XL

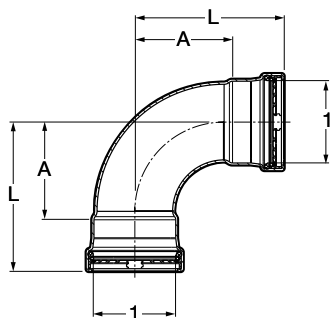

Part No.	Size (in)	A (in)	L (in)
304	316	1	1
85432	80430	2½ x 2½	4.88
85437	80435	3 x 3	5.73
85442	80440	4 x 4	7.22

ProPress Stainless 90° Elbow FTG x P - Models 6016.1 / 4016.1

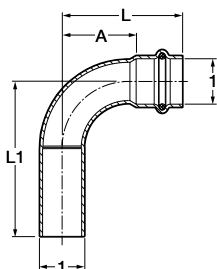

Part No.	Size (in)	A (in)	L (in)	L1 (in)
304	316	1		
85492	80490	½	1.87	1.99
85497	80495	¾	2.35	3.03
85502	80500	1	2.78	3.27
NA	80505	1¼	2.69	2.76
85512	80510	1½	3.41	3.48
85517	80515	2	4.14	4.20

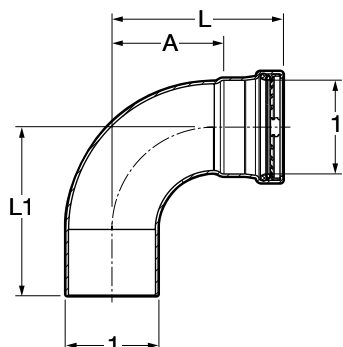
ProPress Stainless 90° Street Elbow P x FTG - Models 6016.1XL / 4016.1XL

Part No.		Size (in)	A (in)	L (in)	L1 (in)
304	316	1 1			
85522	80520	2½ x 2½	3.19	4.88	4.80
85527	80525	3 x 3	3.76	5.73	5.63
85532	80530	4 x 4	4.86	7.22	7.13

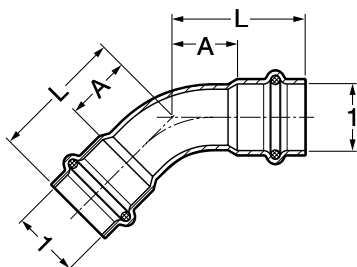
ProPress Stainless 45° Elbow P x P - Models 6026 / 4026

Part No.		Size (in)	A (in)	L (in)
304	316	1		
85447	80445	½	0.57	1.32
85452	80450	¾	0.87	1.77
85457	80455	1	0.89	1.79
85462	80460	1¼	0.69	1.72
85467	80465	1½	0.82	2.25
85472	80470	2	1.06	2.64

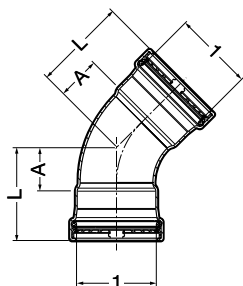
ProPress Stainless 45° Elbow P x P - Models 6026XL / 4026XL

Part No.		Size (in)	A (in)	L (in)
304	316	1 1		
85477	80475	2½ x 2½	1.48	3.18
85482	80480	3 x 3	1.73	3.70
85487	80485	4 x 4	2.19	4.55

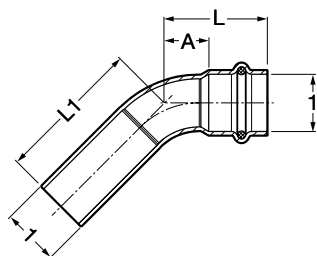
ProPress Stainless 45° Elbow FTG x P - Models 6026.1 / 4026.1

Part No.		Size (in)	A (in)	L (in)	L1 (in)
304	316	1			
85537	80535	½	0.57	1.32	1.46
85542	80540	¾	0.69	1.59	2.27
85547	80545	1	0.89	1.79	2.28
NA	80550	1¼	0.69	1.72	1.79
85557	80555	1½	0.82	2.25	2.32
85562	80560	2	1.06	2.64	2.71

ProPress Stainless 45° Street Elbow P x FTG - Models 6026.1XL / 4026.1XL

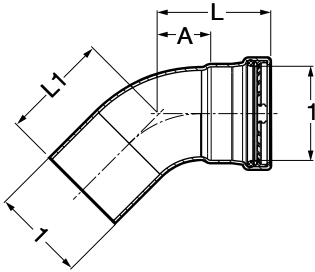

Part No.		Size (in)	A (in)	L (in)	L1 (in)
304	316	1 1			
85567	80565	2½ x 2½	1.48	3.18	3.10
85572	80570	3 x 3	1.73	3.70	3.60
85577	80575	4 x 4	2.19	4.55	4.45

ProPress Stainless Tee P x P x P - Models 6018 / 4018

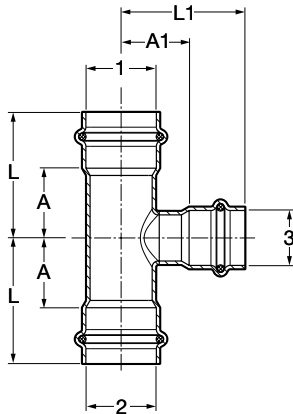

Part No.		Size (in)	A (in)	A1 (in)	L (in)	L1 (in)
304	316	1 2 3				
85632	80630	¾ x ¾ x ½	0.96	0.98	1.86	1.73
85642	80640	1 x 1 x ½	1.13	1.13	2.04	1.88
85652	80650	1 x 1 x ¾	1.13	1.10	2.04	2.01
85662	80660	1¼ x 1¼ x ½	0.75	1.28	1.78	2.03
85672	80670	1¼ x 1¼ x ¾	0.83	1.25	1.86	2.16
85682	80680	1¼ x 1¼ x 1	1.04	1.33	2.08	2.24
85692	80690	1½ x 1½ x ½	1.26	1.39	2.69	2.14
85702	80700	1½ x 1½ x ¾	1.26	1.37	2.69	2.27
85712	80710	1½ x 1½ x 1	1.26	1.44	2.69	2.35
85722	80720	2 x 2 x ½	0.71	1.65	2.30	2.40
85732	80730	2 x 2 x ¾	0.71	1.63	2.30	2.53
85742	80740	2 x 2 x 1	0.83	1.70	2.41	2.61
85752	80750	2 x 2 x 1½	1.15	1.49	2.73	2.91

ProPress Stainless Tee P x P x P - Models 6018XL / 4018XL

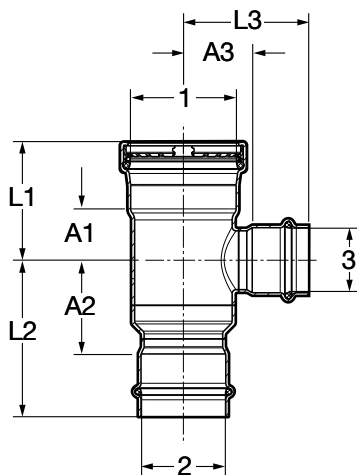

Part No.		Size (in)	A1 (in)	A2 (in)	A3 (in)	L1 (in)	L2 (in)	L3 (in)
304	316	1 2 3						
85955	80753	2½ x 2 x 1½	1.30	2.37	1.74	2.99	3.96	3.17
85954	80752	2½ x 2 x 2	1.54	2.69	1.78	3.23	4.27	3.37
85934	80751	2½ x 2½ x 1½	1.30	1.30	1.74	2.99	2.99	3.17
85904	80760	2½ x 2½ x 2	1.54	1.54	1.78	3.23	3.23	3.37
85612	80610	2½ x 2½ x 2½	1.83	1.83	1.87	3.52	3.52	3.56
85944	80782	3 x 3 x 1¼	1.24	1.24	1.96	3.21	3.21	2.99
85935	80781	3 x 3 x 1½	1.32	1.32	2.00	3.29	3.29	3.43
85905	80770	3 x 3 x 2	1.56	1.56	2.04	3.52	3.52	3.62
85914	80780	3 x 3 x 2½	1.85	1.85	2.13	3.82	3.82	3.82
85617	80615	3 x 3 x 3	2.07	2.07	2.15	4.04	4.04	4.11
85945	80791	4 x 4 x 1½	1.36	1.36	2.51	3.72	3.72	3.94
85915	80790	4 x 4 x 2	1.59	1.59	2.55	3.96	3.96	4.13
85924	80800	4 x 4 x 2½	1.89	1.89	2.64	4.25	4.25	4.33
85925	80810	4 x 4 x 3	2.11	2.11	2.66	4.47	4.47	4.63
85622	80620	4 x 4 x 4	2.60	2.60	2.66	4.96	4.96	5.02

ProPress Stainless Reducing Tee P x P x FPT - Models 6017.2 / 4017.2

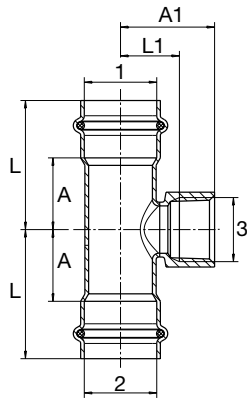

Part No.		Size (in)			A (in)	A1 (in)	L (in)	L1 (in)
304	316	1	2	3				
85822	80820	¾ x ¾ x ½ FPT			0.96	0.76	1.86	1.26
85832	80830	¾ x ¾ x ¾ FPT			0.96	0.78	1.86	1.34
85842	80840	1 x 1 x ½ FPT			1.13	0.87	2.04	1.41
85852	80850	1 x 1 x ¾ FPT			1.13	0.93	2.04	1.48
85862	80860	1¼ x 1¼ x ½ FPT			0.75	1.02	1.78	1.56
85872	80870	1¼ x 1¼ x ¾ FPT			0.83	1.08	1.86	1.63
85882	80880	1¼ x 1¼ x 1" FPT			1.04	1.09	2.08	1.75
85892	80890	1½ x 1½ x ½ FPT			1.26	1.13	2.69	1.67
85902	80900	1½ x 1½ x ¾ FPT			1.26	1.19	2.69	1.75
85912	80910	1½ x 1½ x 1 FPT			1.26	1.20	2.69	1.87
85922	80920	2 x 2 x ½ FPT			0.71	1.39	2.30	1.93
85932	80930	2 x 2 x ¾ FPT			0.71	1.45	2.30	2.01
85942	80940	2 x 2 x 1 FPT			0.83	1.50	2.41	2.13

ProPress Stainless Reducing Tee P x P x FPT - Models 6017.2XL / 4017.2XL

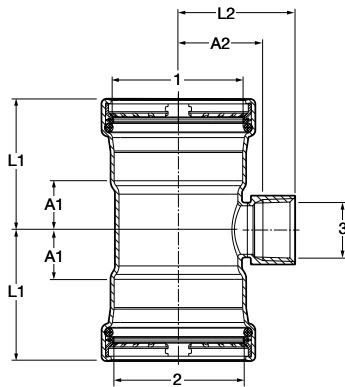

Part No.		Size (in)			A1 (in)	A2 (in)	L1 (in)	L2 (in)
304	316	1	2	3				
85952	80950	2½ x 2½ x ¾			1.02	1.73	2.72	2.28
85962	80960	2½ x 2½ x 1			1.02	1.74	2.72	2.38
85972	80970	3 x 3 x ¾			1.04	1.98	3.01	2.54
85982	80980	3 x 3 x 1			1.04	1.98	3.01	2.64
85992	80990	4 x 4 x ¾			1.08	2.50	3.44	3.05
86002	81000	4 x 4 x 1			1.08	2.49	3.44	3.15

ProPress Stainless Cross P x P x FPT x FPT - Model 4044.2XL

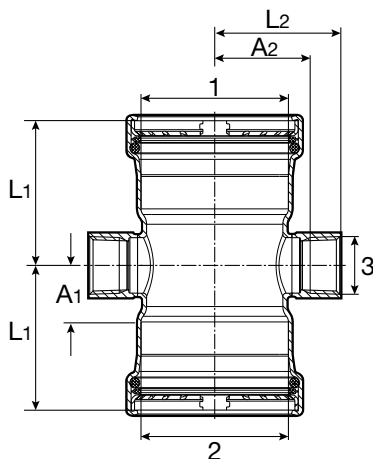

Part No.		Size (in)			A1 (in)	A2 (in)	L1 (in)	L2 (in)
316	1	2	3					
80067	2½ x 2½ x ¾			1.02	1.73	2.62	2.28	
80069	3 x 3 x ¾			1.04	1.98	3.01	2.54	
80068	4 x 4 x ¾			1.08	2.50	3.44	3.05	

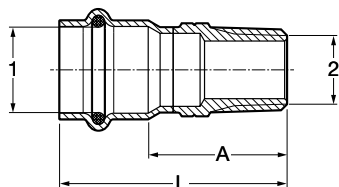
ProPress Stainless Adapter P x MPT - Models 6011 / 4011

Part No.		Size (in)		A (in)	L (in)
304	316	1	2		
85012	80010	1/2 x 1/2 MPT		1.37	2.11
85017	80015	1/2 x 3/4 MPT		1.44	2.19
85022	80020	3/4 x 1/2 MPT		1.42	2.32
85027	80025	3/4 x 3/4 MPT		1.46	2.36
85032	80030	3/4 x 1 MPT		1.71	2.62
85037	80035	1 x 3/4 MPT		1.47	2.37
85042	80040	1 x 1 MPT		1.74	2.65
85047	80045	1 1/4 x 1 1/4 MPT		1.89	2.92
85052	80050	1 1/2 x 1 1/2 MPT		1.94	3.37
85054	80055	2 x 2 MPT		2.10	3.68

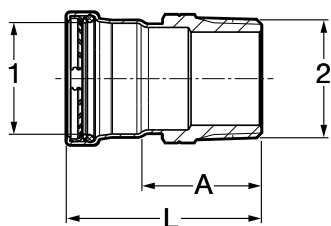
ProPress Stainless Adapter P x MPT - Models 6011XL / 4011XL

Part No.		Size (in)		A (in)	L (in)
304	316	1	2		
85062	80060	2 1/2 x 2 1/2 MPT		2.99	4.69
85067	80065	3 x 3 MPT		3.09	5.06
85072	80070	4 x 4 MPT		3.13	5.49

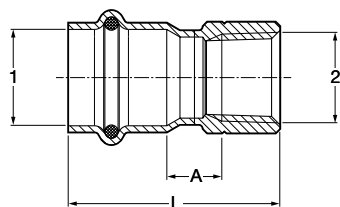
ProPress Stainless Adapter P x FPT - Models 6012 / 4012

Part No.		Size (in)		A (in)	L (in)
304	316	1	2		
85082	80080	1/2 x 1/2 FPT		0.54	1.82
85087	80085	3/4 x 1/2 FPT		0.51	1.95
85096	80090	3/4 x 3/4 FPT		0.57	2.03
85094	80092	1 x 1/2 FPT		0.62	2.06
85097	80095	1 x 3/4 FPT		0.62	2.08
85128	80100	1 x 1 FPT		0.61	2.18
85107	80105	1 1/4 x 1 1/4 FPT		0.62	2.33
NA	80110	1 1/2 x 1 1/4 FPT		0.69	2.80
85117	80115	1 1/2 x 1 1/2 FPT		0.69	2.80
85077	80075	2 x 1 FPT		0.75	2.99
85122	80120	2 x 1 1/2 FPT		0.73	2.99
85127	80125	2 x 2 FPT		0.71	2.99

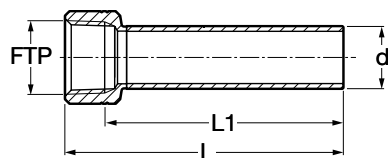
ProPress 316 Instrument Adapter - Model 4012.5

Part No.	Size (in)	L (in)	L1 (in)
316	FPT x FTG (d)		
80126	1/2 x 1/2	4.06	3.52
80127	3/4 x 3/4	3.94	3.38

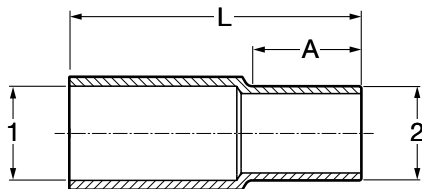
ProPress 304 Adapter BW (IPS) x FTG (CTS) - Model 0113.3

Part No.	Size (in)		A (in)	L (in)
	(1) IPS	(2) CTS		
304				
86003	½ ID	½ OD	0.87	2.40
86008	¾ ID	¾ OD	1.02	2.74
86013	1 ID	1 OD	1.06	2.78
86023	1½ ID	1½ OD	1.57	4.12
86028	2 ID	2 OD	1.73	4.27

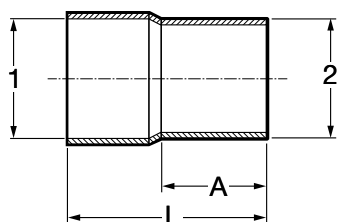
ProPress Stainless Adapter BW (IPS) x FTG - Models 0113.1XL / 4013.1XL

Part No.	304	316	Size (in)		A (in)	L (in)
			1 (IPS)	2 (CTS)		
85135	80081	2½ ID	2½ OD	2.32	4.37	
85145	80082	3 ID	3 OD	2.60	4.57	
85155	80083	4 ID	4 OD	2.99	5.16	

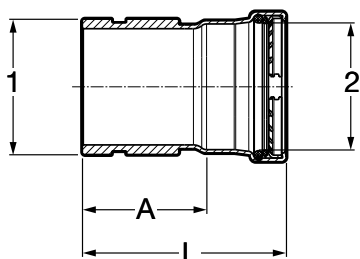
ProPress Stainless Adapter Groove x P - Model 4013.2XL

Part No.	Size (in)		A (in)	L (in)
	316	1 G (IPS)		
80064	2½	2½	2.64	4.33
80061	3	3	2.66	4.63
80063	4	4	2.66	5.02

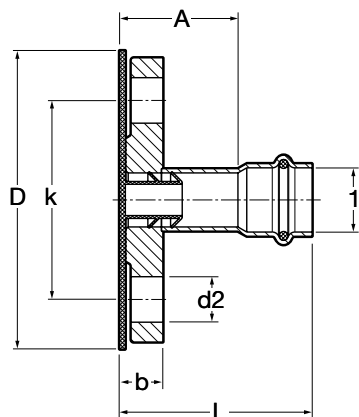
ProPress Stainless Adapter Flange P x Flange - Models 6059 / 4059

Part No.	304	316	Size (in)	b (in)	A (in)	L (in)	k (in)	D (in)	d2 (in)
86082	81035	½	0.46	1.72	2.46	2.36	3.54	0.63	
86087	81040	¾	0.52	1.66	2.57	2.76	3.94	0.63	
86092	81045	1	0.58	1.60	2.51	3.11	4.33	0.63	
86097	81050	1¼	0.64	1.66	2.69	3.50	4.53	0.63	
86102	81055	1½	0.70	1.41	2.83	3.86	4.92	0.63	
86107	81060	2	0.77	2.30	3.86	4.76	5.91	0.75	

ProPress Stainless Adapter Flange P x Flange - Models 6059XL / 4059XL

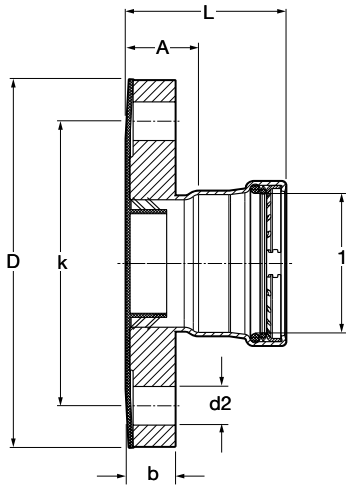

Part No.		Size (in)	b (in)	A (in)	L (in)	k (in)	D (in)	d2 (in)
304	316	1						
86067	81065	2½	0.89	1.35	3.04	5.51	7.09	0.75
86072	81070	3	0.96	1.39	3.40	5.98	7.48	0.75
86077	81075	4	0.96	1.40	3.77	7.52	9.06	0.75

ProPress Stainless Cap P - Models 6056 / 4056

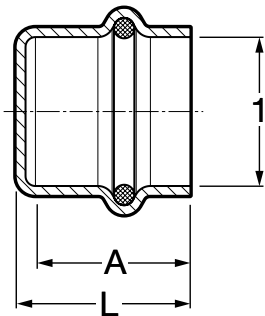

Part No.		Size (in)	A (in)	L (in)
304	316	1		
85357	80355	½	0.70	0.82
85362	80360	¾	0.93	1.04
86367	80365	1	0.94	1.06
86372	80370	1¼	1.04	1.20
86377	80375	1½	1.44	1.59
86382	80380	2	1.59	1.74

ProPress Stainless Cap P - Models 6056.1XL / 4056.1XL

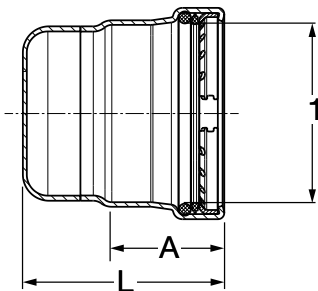

Part No.		Size (in)	A (in)	L (in)
304	316	1		
85387	80385	2½	1.69	3.01
85392	80390	3	1.97	3.33
85397	80395	4	2.36	3.72

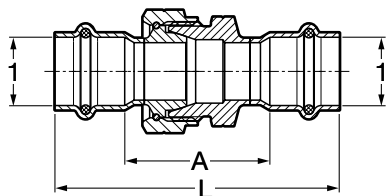
ProPress Stainless Union P x P - Models 6060 / 4060

Part No.		Size (in)	A (in)	L (in)
304	316	1		
86007	81005	1/2	1.87	3.37
86012	81010	3/4	1.89	3.70
86017	81015	1	2.25	4.06
86022	81020	1 1/4	2.25	4.31
86027	81025	1 1/2	2.68	5.53
86032	81030	2	2.95	6.12

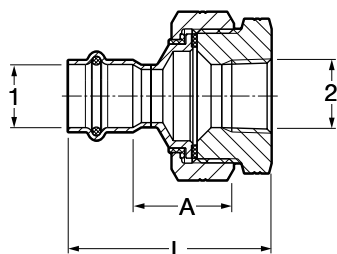
ProPress 316 Dielectric Union P x FPT - Model 4067

Part No.	Size (in)	A (in)	L (in)
316	1 2		
80071	1/2 x 1/2 FPT	1.28	2.57
80078	3/4 x 3/4 FPT	1.39	2.85
80073	1 x 1 FPT	1.25	2.81
80074	1 1/4 x 1 1/4 FPT	1.33	3.04
80076	1 1/2 x 1 1/2 FPT	1.54	3.64
80077	2 x 2 FPT	1.72	4.00

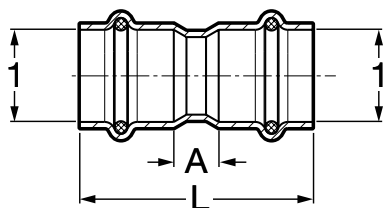
ProPress Stainless Coupling with Stop P x P - Models 6015 / 4015

Part No.		Size (in)	A (in)	L (in)
304	316	1		
85267	80265	1/2	0.35	1.85
85272	80270	3/4	0.43	2.24
85277	80275	1	0.39	2.20
85282	80280	1 1/4	0.47	2.54
85287	80285	1 1/2	0.36	3.21
85292	80290	2	0.47	3.64

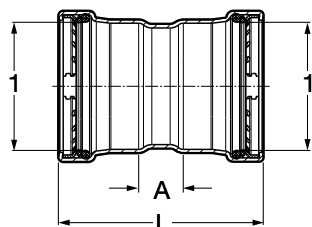
ProPress Stainless Coupling with Stop P x P - Models 6015XL / 4015XL

Part No.		Size (in)	A (in)	L (in)
304	316	1 1		
85297	80295	2 1/2 x 2 1/2	0.95	4.33
85302	80300	3 x 3	0.98	4.92
85307	80305	4 x 4	1.06	5.79

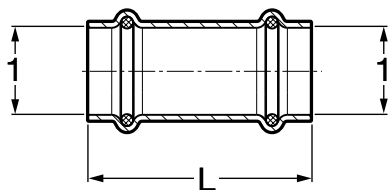
ProPress Stainless Coupling No Stop P x P - Models 6015.5 / 4015.5

Part No.		Size (in)		L (in)
304	316	1		
85312	80310	1/2		1.87
85317	80315	3/4		2.27
85322	80320	1		2.19
85327	80325	1 1/4		2.54
85332	80330	1 1/2		3.27
85337	80335	2		3.66

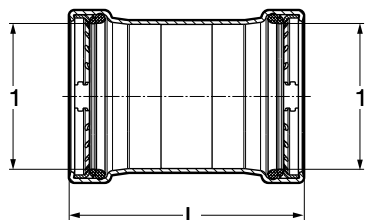
ProPress Stainless Coupling No Stop P x P - Models 6015.5XL / 4015.5XL

Part No.		Size (in)		L (in)
304	316	1	1	
85342	80340	2 1/2 x 2 1/2		4.33
85347	80345	3 x 3		4.92
85352	80350	4 x 4		5.79

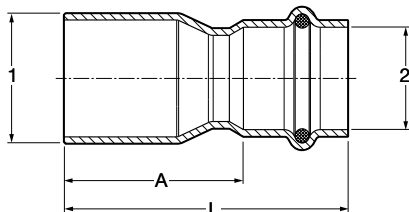
ProPress Stainless Reducer FTG x P - Models 6015.1 / 4015.1

Part No.		Size (in)		A (in)	L (in)
304	316	1	2		
85162	80160	3/4 x 1/2		1.54	2.28
85167	80165	1 x 1/2		1.84	2.59
85172	80170	1 x 3/4		1.56	2.46
85173	80175	1 1/4 x 1/2		2.25	3.00
85182	80180	1 1/4 x 3/4		1.93	2.83
85187	80185	1 1/4 x 1		1.81	2.72
85192	80190	1 1/2 x 1/2		3.03	3.78
85197	80195	1 1/2 x 3/4		2.64	3.54
85202	80200	1 1/2 x 1		2.50	3.41
NA	80205	1 1/2 x 1 1/4		2.26	3.29
85212	80210	2 x 1/2		3.75	4.50
85217	80215	2 x 3/4		3.48	4.39
85222	80220	2 x 1		3.08	3.99
NA	80225	2 x 1 1/4		2.94	3.97
85232	80230	2 x 1 1/2		2.59	4.02

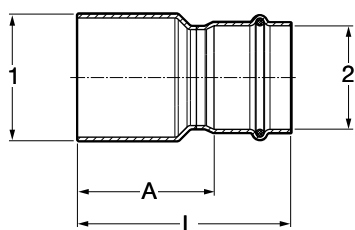
ProPress Stainless Reducer FTG x P - Models 6015.1XL / 4015.1XL

Part No.		Size (in)		A (in)	L (in)
304	316	1	2		
85237	80235	2 1/2 x 2		2.85	4.43
85242	80240	3 x 2		3.38	4.96
85247	80245	3 x 2 1/2		3.21	4.90
85252	80250	4 x 2		4.26	5.85
85257	80255	4 x 2 1/2		4.09	5.79
85262	80260	4 x 3		3.88	5.85

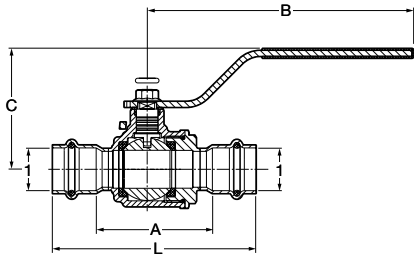
ProPress 316 Ball Valve P x P - Model 4070

Part No.	Size (in)	A (in)	L (in)	B (in)	C (in)
316	1				
81080	1/2	2.06	3.56	5.55	2.44
81085	3/4	2.42	4.23	5.55	2.52
81090	1	2.76	4.59	5.55	2.68
81095	1 1/4	3.17	5.23	6.10	3.09
81100	1 1/2	3.65	6.50	6.10	3.34
81105	2	4.15	7.32	6.10	3.66

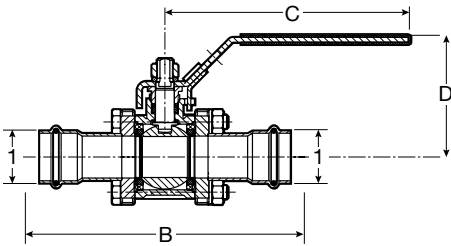
ProPress 316 3-Piece Ball Valve P x P - Model 4370.8

Part No.	Size (in)	B (in)	C (in)	D (in)
316	1			
85132	1/2	5.41	3.99	2.28
85133	3/4	5.79	5.88	2.85
85134	1	6.00	5.88	2.93
85136	1 1/4	6.61	7.54	3.27
85137	1 1/2	7.26	7.54	3.57
85138	2	9.67	7.54	3.89

5 Limited Warranty

Viega ProPress Fittings and Valves

Subject to the conditions and limitations in this Limited Warranty, Viega LLC (VIEGA) warrants to wholesalers and licensed plumbing and mechanical contractors in the United States and Canada that its ProPress fittings, when properly installed in non-industrial and non-marine applications and under normal conditions of use, will be free of failure from manufacturing defect for a period of fifty (50) years from date of installation and that its ProPress valves, when properly installed in non-industrial and non-marine applications and under normal conditions of use, will be free of failure from manufacturing defect for a period of two (2) years from date of installation.

Under this Limited Warranty, you only have a right to a remedy if the failure or leak resulted from a manufacturing defect in the products covered by this warranty and the failure or leak occurred during the warranty period. You do not have a remedy under this warranty and the warranty does not apply if the failure or any resulting damage is caused by (1) components other than those manufactured or sold by Viega; (2) not designing, installing, inspecting, or testing the ProPress fittings or valves in accordance with Viega's installation instructions in effect at the time of the installation; applicable code requirements; and accepted industry practice; (3) improper handling and protection of the product prior to and during installation, inadequate freeze protection, exposure to water pressures or temperatures or in applications outside acceptable operating conditions; (4) acts of nature such as, but not limited to, earthquakes, fire, flood, or lightning, or (5) external environmental causes, such as water quality variations, aggressive water, or other external chemical or physical conditions.

In the event of a leak or other failure of the parts covered by this warranty, it is the responsibility of the property owner to obtain and pay for repairs. Only if the warranty applies will Viega be responsible for the remedy under this warranty. The part or parts which you claim failed should

be kept and Viega contacted by writing to the address below or telephoning 1-800-976-9819 within thirty (30) days after the leak or other failure and identifying yourself as having a warranty claim. You should be prepared to ship, at your expense, the product which you claim failed due to a manufacturing defect and document the date of installation. Within a reasonable time after receiving the product, Viega will investigate the reasons for the failure, which includes the right to inspect the product at Viega. Viega will notify you in writing of the results of its review.

In the event that Viega determines that the failure or leak as the result of a manufacturing defect in the part covered by this warranty and that this warranty applies, the **EXCLUSIVE AND ONLY REMEDY** under this warranty shall be the reimbursement for repair and/or replacement of the part. **VIEGA SHALL NOT BE LIABLE FOR ANY CONSEQUENTIAL OR OTHER DAMAGE (FOR EXAMPLE, WATER OR PROPERTY OR MOLD REMEDIATION) UNDER ANY LEGAL THEORY AND WHETHER ASSERTED BY DIRECT ACTION, FOR CONTRIBUTION OR INDEMNITY OR OTHERWISE.**

THE ABOVE WARRANTY IS IN LIEU OF ALL OTHER WARRANTIES, EXPRESS OR IMPLIED, INCLUDING BUT NOT LIMITED TO THE IMPLIED WARRANTIES OF MERCHANTABILITY AND FITNESS FOR A PARTICULAR PURPOSE. If a limited warranty shall be found to apply, such warranty is limited to four years. Other than this Limited Warranty, Viega does not authorize any person or firm to create for it any other obligation or liability in connection with its products.

This Limited Warranty gives you specific legal rights and you also may have other rights which may vary from state to state. This warranty shall be interpreted and applied under the law of the state in which the product is installed and is intended as a Commercial Warranty.

Limited Warranty

Viega Metal Systems for Industrial Applications

Industrial applications are defined as non-residential and non-commercial applications not normally accessible to the general public, including manufacturing, mining, process or fabrication environments.

Subject to the terms and conditions of this Limited Warranty, Viega LLC (Viega) warrants to end users, installers and distribution houses that its Viega metal press products (Viega product) when properly installed in industrial applications shall be free from failure caused by manufacturing defects for a period of two (2) years from date of installation.

Under this Limited Warranty, you only have a right to a remedy if the failure or leak resulted from a manufacturing defect in the Viega product and the failure or leak occurs during the warranty period. You do not have a remedy under this warranty and the warranty remedy does not apply if the failure or any resulting damage is caused by (1) components other than those sold by Viega; (2) not designing, installing, inspecting, testing, or maintaining the Viega product in accordance with Viega's installation and product instructions in effect at the time of installation and other specifications and approvals applicable to the installation; (3) improper handling and protection of the Viega product prior to, during and after installation, inadequate freeze protection, or exposure to environmental or operating conditions not recommended for the application; or (4) acts of nature, such as, but not limited to earthquakes, fire, or weather damage. Final approval as to use compatibility to a specific process or fluid application is the responsibility of the engineer of record or responsible design/facilities personnel and this Limited Warranty only applies to manufacturing defects in the Viega Product.

In the event of a leak or other failure in the Viega product covered by this warranty, it is the responsibility of the end user to take appropriate measures to diminish any damage, to include making timely repairs. Only if the warranty applies will Viega be responsible for the remedy under this warranty. The part or parts which you claim failed should be kept and Viega contacted by writing to the address below or telephoning 1-800-976-9819 within

thirty (30) calendar days after the leak or other failure and identifying yourself as having a warranty claim. You should be prepared to ship, at your expense, the product which you claim failed due to a manufacturing defect, document the date of installation, and the amount of the repair or replacement if performed by you. Within a reasonable time after receiving the product, Viega will investigate the reasons for the failure, which includes the right to inspect the product at a Viega location and reasonable access to the site of damage. Viega will notify you in writing as to the results of its review.

In the event that Viega determines that the failure or leak was the result of a manufacturing defect in the Viega Product covered by this warranty and to which this warranty applies, the EXCLUSIVE AND ONLY REMEDY under this warranty shall be the reimbursement for reasonable charges for repair or replacement of the Viega Product itself. VIEGA SHALL NOT BE LIABLE FOR CONSEQUENTIAL OR OTHER DAMAGE (FOR EXAMPLE, ECONOMIC LOSS, WATER OR PROPERTY OR MOLD REMEDIATION) UNDER ANY LEGAL THEORY AND WHETHER ASSERTED BY DIRECT ACTION, FOR CONTRIBUTION OR INDEMNITY OR OTHERWISE.

THE ABOVE WARRANTY IS IN LIEU OF ALL OTHER WARRANTIES, EXPRESS OR IMPLIED, INCLUDING, BUT NOT LIMITED TO, THE IMPLIED WARRANTIES OR ANY STATUTE OF LIMITATIONS RELATING TO SUCH WARRANTIES. Other than this Limited Warranty, Viega does not authorize any person or firm to create for it any other obligation or liability in connection with its products.

This Limited Warranty gives you specific legal rights and you also may have other rights which may vary from state to state. This warranty shall be interpreted and applied under the law of the state in which the product is installed and is intended as a Commercial Warranty.

Limited Warranty

Viega Marine Applications

Marine applications are defined as mobile structures used to navigate water or stationary structures in water.

Subject to the terms and conditions of this Limited Warranty, Viega LLC (Viega) warrants to end users, installers and distribution houses that its Viega metal press products (Viega product) when properly installed in approved marine applications and other products sold by Viega LLC when properly installed in marine applications in accordance with our listings shall be free from failure caused by manufacturing defects for a period of two (2) years from date of installation. This warranty applies only to approved applications. Installations that are not approved shall not be covered by this warranty and shall not be the responsibility of Viega LLC.

Under this Limited Warranty, you only have a right to a remedy if the failure or leak resulted from a manufacturing defect in the Viega product and the failure or leak occurs during the warranty period. You do not have a remedy under this warranty and the warranty remedy does not apply if the failure or any resulting damage is caused by (1) components other than those sold by Viega; (2) not designing, installing, inspecting, testing, or maintaining the Viega product in accordance with Viega's installation and product instructions in effect at the time of installation and other specifications and approvals applicable to the installation; (3) improper handling and protection of the Viega product prior to, during and after installation, inadequate freeze protection, or exposure to environmental or operating conditions not recommended for the application; or (4) acts of nature, such as, but not limited to earthquakes, fire, or weather damage. Final approval as to use compatibility to a specific process or fluid application is the responsibility of the engineer of record or responsible design/facilities personnel and this Limited Warranty only applies to manufacturing defects in the Viega Product.

In the event of a leak or other failure in the Viega product covered by this warranty, it is the responsibility of the end user to take appropriate measures to diminish any damage, to include making timely repairs. Only if the warranty applies will Viega be responsible for the remedy

under this warranty. The part or parts which you claim failed should be kept and Viega contacted by writing to the address below or telephoning 1-800-976-9819 within thirty (30) calendar days after the leak or other failure and identifying yourself as having a warranty claim. You should be prepared to ship, at your expense, the product which you claim failed due to a manufacturing defect, document the date of installation, and the amount of the repair or replacement if performed by you. Within a reasonable time after receiving the product, Viega will investigate the reasons for the failure, which includes the right to inspect the product at a Viega location and reasonable access to the site of damage. Viega will notify you in writing as to the results of its review.

In the event that Viega determines that the failure or leak was the result of a manufacturing defect in the Viega Product covered by this warranty and to which this warranty applies, the EXCLUSIVE AND ONLY REMEDY under this warranty shall be the reimbursement for reasonable charges for repair or replacement of the Viega Product itself. VIEGA SHALL NOT BE LIABLE FOR CONSEQUENTIAL OR OTHER DAMAGE (FOR EXAMPLE, ECONOMIC LOSS, WATER OR PROPERTY OR MOLD REMEDIATION) UNDER ANY LEGAL THEORY AND WHETHER ASSERTED BY DIRECT ACTION, FOR CONTRIBUTION OR INDEMNITY OR OTHERWISE.

THE ABOVE WARRANTY IS IN LIEU OF ALL OTHER WARRANTIES, EXPRESS OR IMPLIED, INCLUDING, BUT NOT LIMITED TO, THE IMPLIED WARRANTIES OR ANY STATUTE OF LIMITATIONS RELATING TO SUCH WARRANTIES. Other than this Limited Warranty, Viega does not authorize any person or firm to create for it any other obligation or liability in connection with its products.

This Limited Warranty gives you specific legal rights and you also may have other rights which may vary from state to state. This warranty shall be interpreted and applied under the law of the state in which the product is installed and is intended as a Commercial Warranty.

 **Viega LLC**
585 Interlocken Blvd.
Broomfield, CO 80021

Phone (800) 976-9819
www.viega.us

SM-PP 0520 ProPress Stainless

