

Product Instructions

viega

Viega® Programmable Heat/Cool Thermostat

The Viega programmable heat/cool thermostat is easy to install, easy to wire and easy to program. It can be used for single stage heating and cooling applications, making it ideal for many different applications. Installation instructions can be found below.

Thermostat applications guide

Description	
Gas or Oil Heat	Yes
Electric Furnace	Yes
Heat Pump (No Aux. or Emergency Heat)	Yes
Heat Pump (with Aux. or Emergency Heat)	No
Multi-stage Systems	No
Heat Only Systems	Yes
Cool Only Systems	Yes

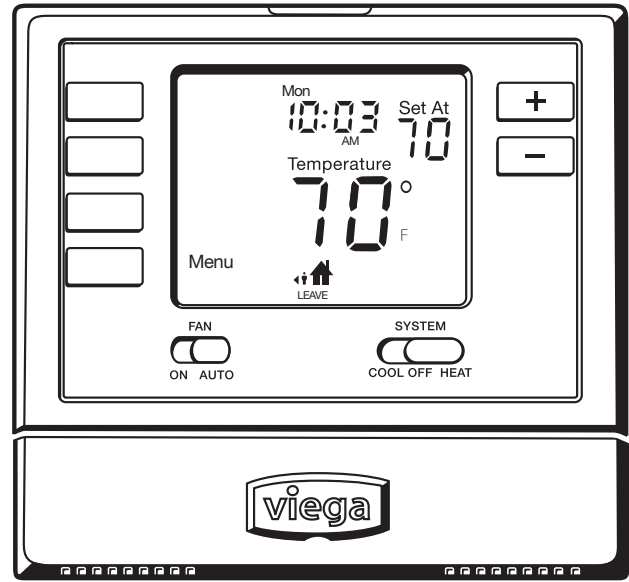

Part Number 15117

Mounting the subbase

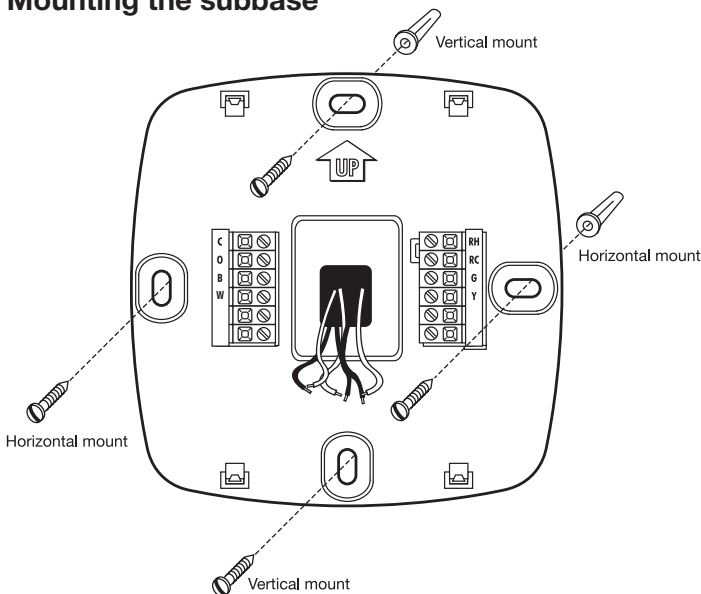

For vertical mount put one screw top and one screw bottom. For horizontal mount put one screw left and one screw right. The thermostat can be mounted directly to the wall or it can be mounted to a wall box. Use the vertical mounting screw location to attach to a wall box.

Caution: Electrical Hazard
Failure to disconnect the power before beginning to install this product can cause electrical shock or equipment damage.

Mercury Notice:
All of our products are mercury free. However, if the product you are replacing contains mercury, dispose of it properly. Your local waste management authority can give you instructions on recycling and proper disposal.

A trained, experienced technician must install this product. Carefully read these instructions. You could damage this product or cause a hazardous condition if you fail to follow these instructions.

Product Instructions

viega

Installation tips

Wall locations

The thermostat should be installed approximately 4 to 5 feet above the floor. Select an area with average temperature and good air circulation.

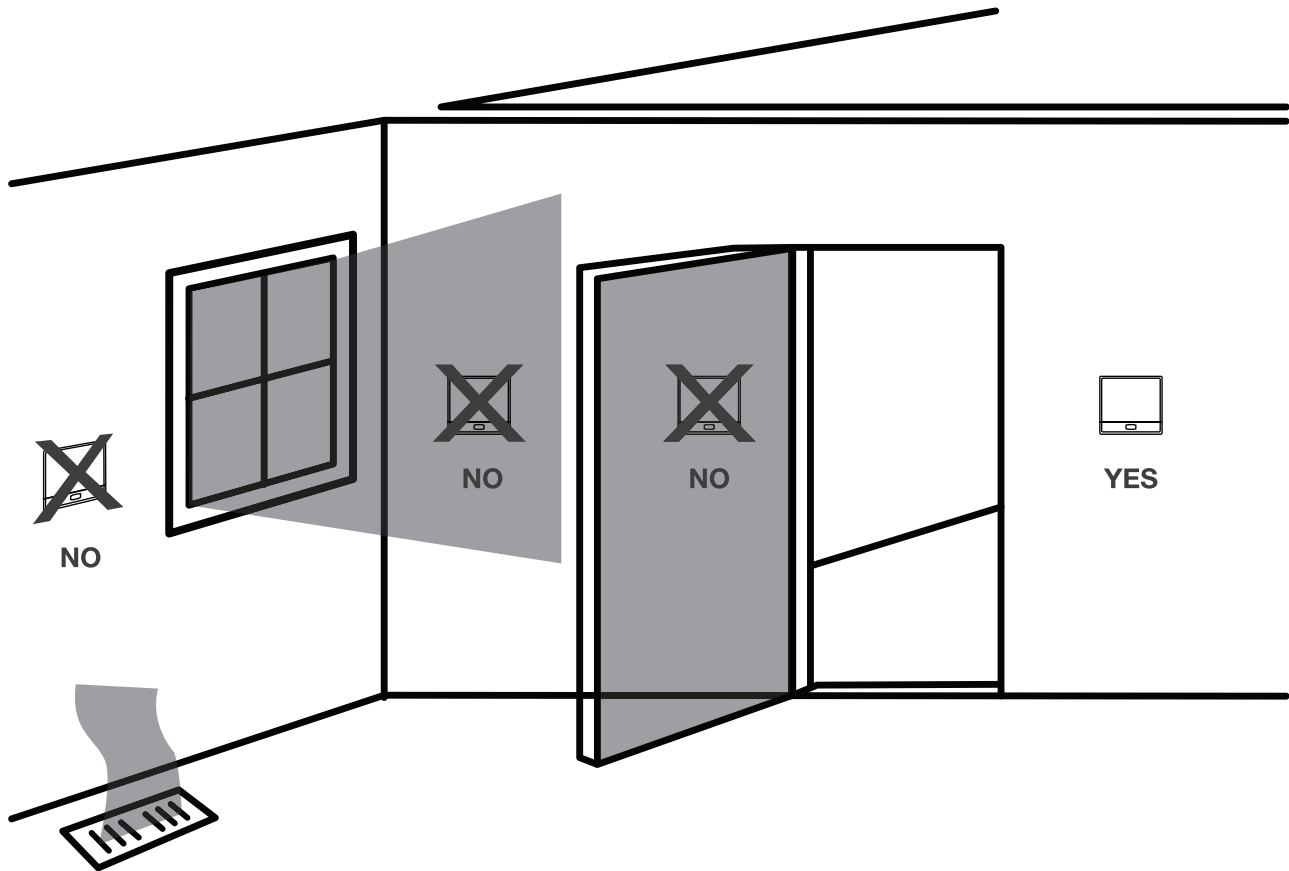

Do not install thermostat in locations:

- Close to hot or cold air ducts
- That are in direct sunlight
- With an outside wall behind the thermostat
- In areas that do not require conditioning
- Where there are dead spots or drafts (in corners or behind doors)
- Where there might be concealed chimneys or pipes

NOTE: Pick an installation location that is easy for the user to access. The temperature of the location should be representative of the building

Product Instructions

viega

Thermostat wiring

1. If you are replacing a thermostat, make note of the terminal connections on the thermostat that is being replaced. In some cases the wiring connections will not be color coded. For example, the green wire may not be connected to the G terminal.
2. Loosen the terminal block screws. Insert wires then retighten terminal block screws.

Viega thermostat terminal conversion

Thermostat	Thermostats	Zone Control	Zone Control
15118	15116	18060	18032
	15117	18062	Thermostat
		18050	18029

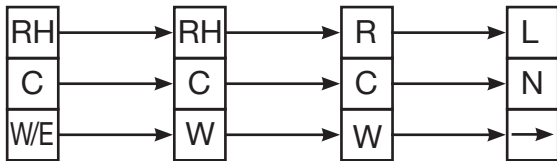

Power type

- 3 wire
- 3 wire with battery backup
- 2 wire with battery

Terminal designations

- W - Heat relay
- Y - Compressor relay
- G - Fan relay
- O - Heat pump changeover valve energized in cooling
- RC - Transformer power for cooling
- RH - Transformer power for heating
- B - Heat pump changeover valve energized in heating
- C - Common wire from secondary side of cooling system transformer

Wiring tips:

RH & RC terminals

For single transformer systems, leave the jumper wire in place between RH and RC. Remove jumper wire for two transformer systems.

Heat pump systems

If wiring to a heat pump, use a small piece of wire (not supplied) to connect terminals W and Y.

C terminal

The C (common wire) terminal does not have to be connected when the thermostat is powered by batteries.

Wire specifications

Use shielded or non-shielded 18-22 gauge thermostat wire.



Caution: Electrical hazard

Failure to disconnect the power before beginning to install this product can cause electrical shock or equipment damage.



Warning:

All components of the control system and the thermostat installation must conform to Class II circuits per the NEC Code.

Product Instructions

viega

Typical industry wiring diagrams

- ▲ 1 Power supply
- ▲ 2 Factory-installed jumper. Remove only when installing on 2-transformer systems.
- ▲ 3 Use either O or B terminals for changeover valve
- ▲ 4 Use a small piece of wire (not supplied) to connect W and Y terminals
- ▲ 5 Set fan operation switch to electric. See page 8.
- ▲ 6 Optional 24 VAC common connection when thermostat is used in battery power mode

Typical 1H/1C system: 1 transformer

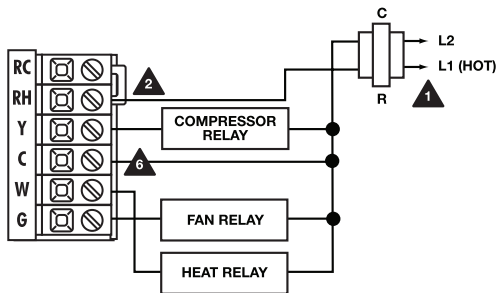

Typical 1H/1C system: 2 transformer

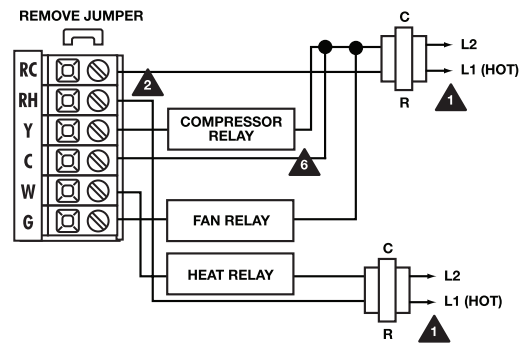

Typical 1H/1C heat pump system

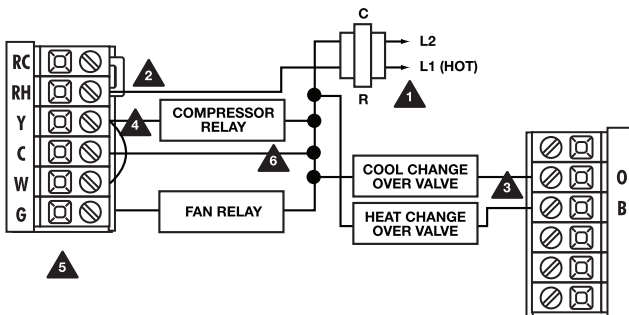

Typical heat-only system

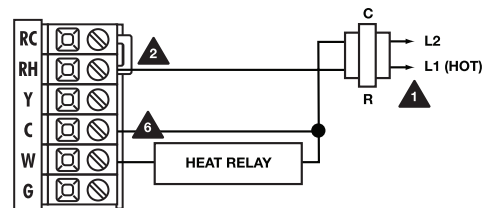

Typical heat-only system with fan

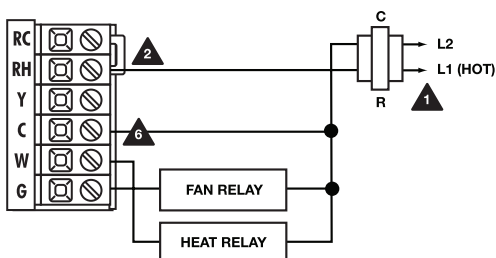

Typical cool-only system

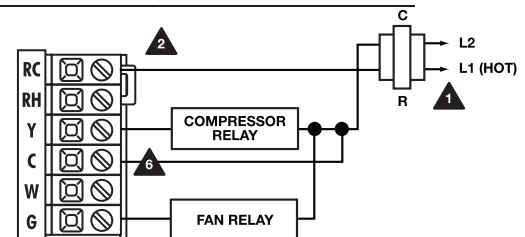

Viega LLC, 301 N. Main, 9th Floor • Wichita, KS 67202 • Ph: 800-976-9819 • Fax: 316-425-7618

Product Instructions

viega

Viega wiring diagrams

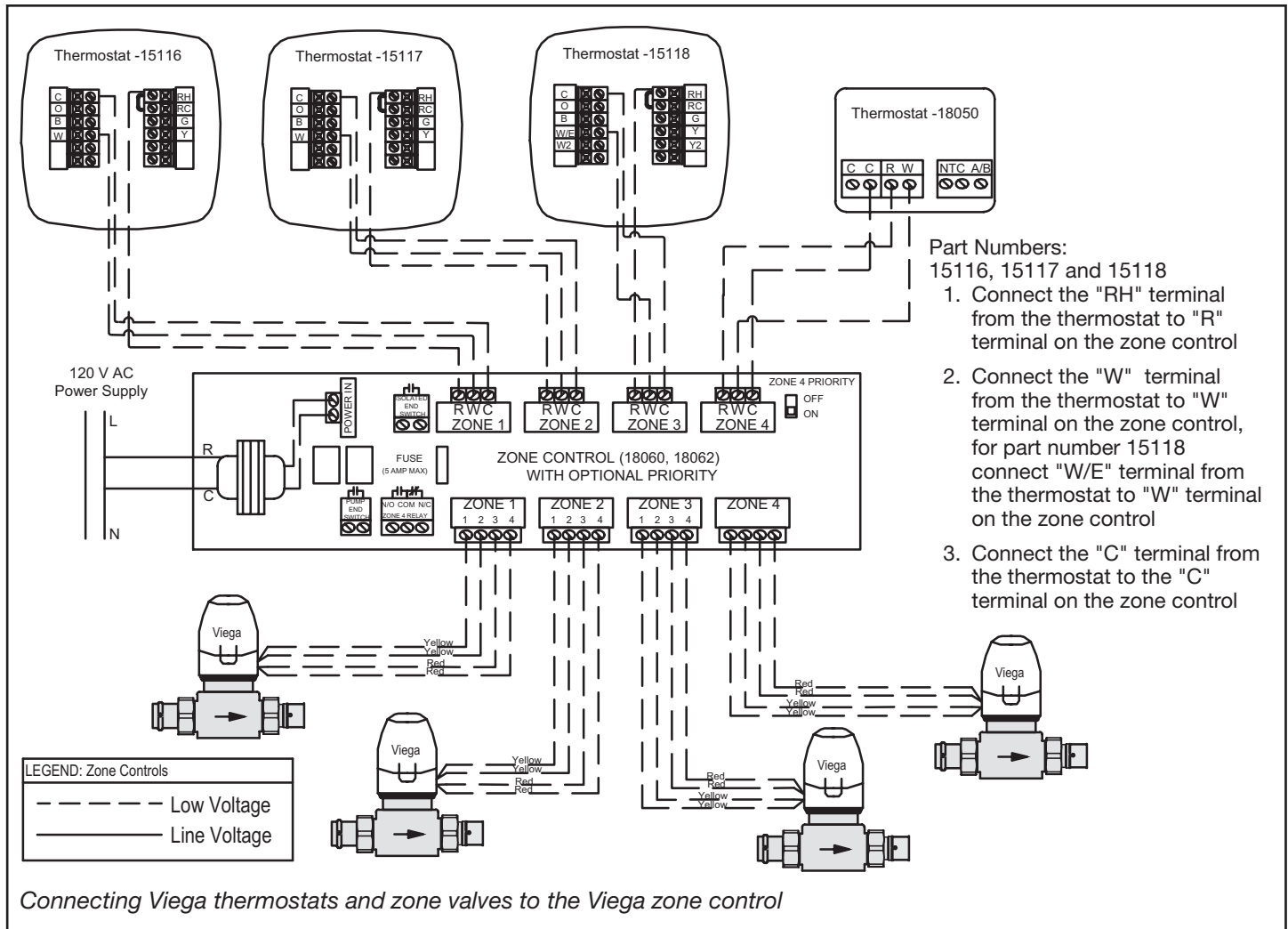

Product Instructions

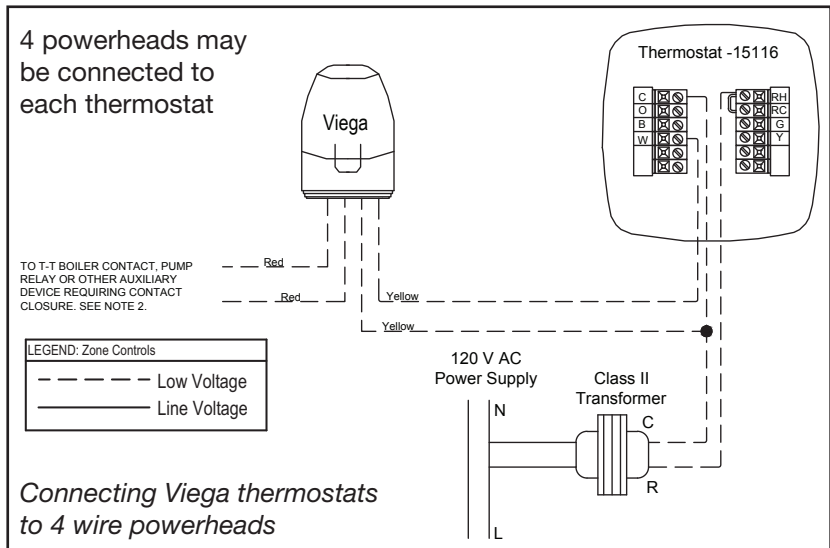
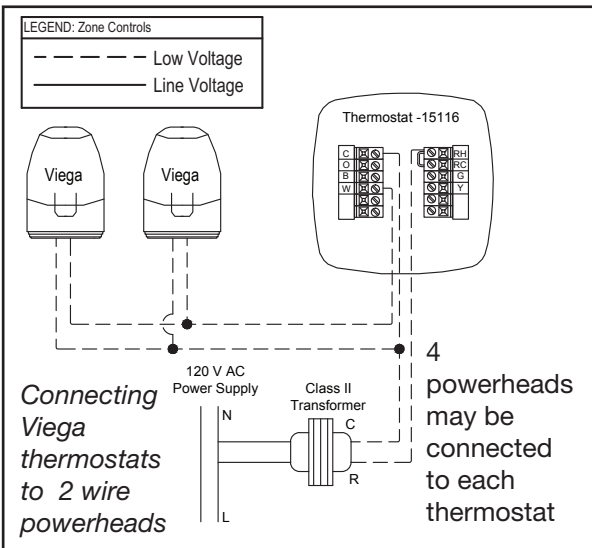
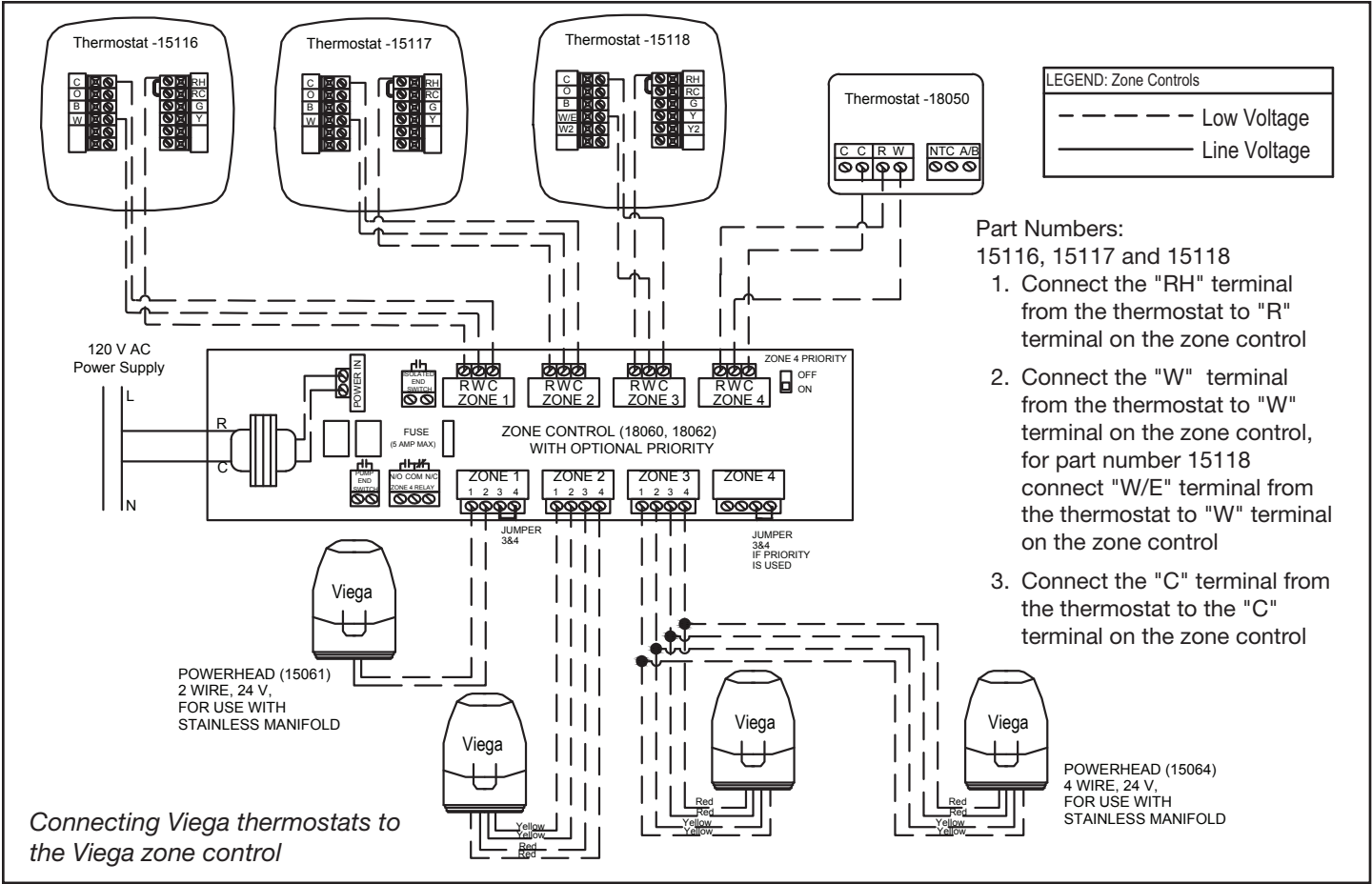

Product Instructions

viega

Thermostat display

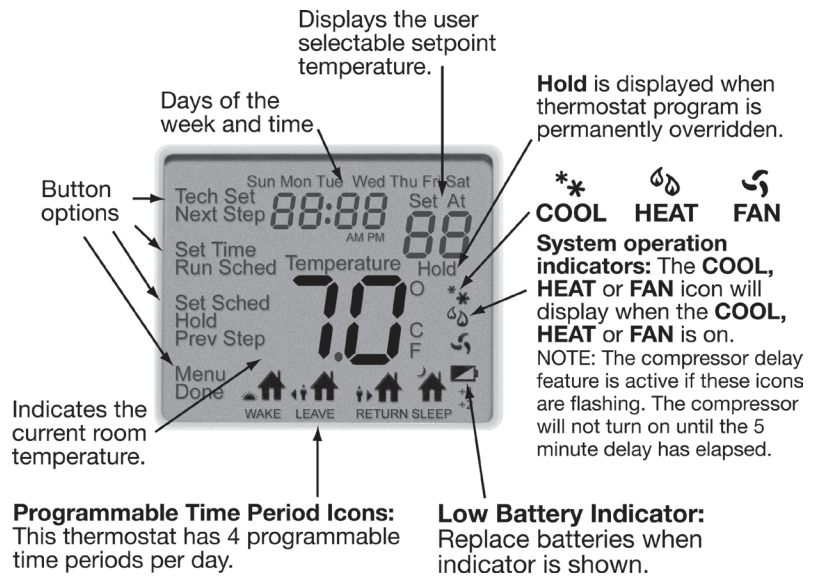

- ① LCD
- ② Glow in the dark light button
 - Push the glow in the dark button and the screen will illuminate.
- ③ Fan switch
 - Set to **AUTO** to run the fan anytime heating or cooling is running.
 - Set to **ON** to run the fan at all times.
- ④ System switch
 - Set to heating/cooling or off.
- ⑤ Easy change battery door
 - 2- AA batteries included.
- ⑥ Temperature setpoint buttons
 - Use the **+** or **-** buttons to adjust the room temperature.
- ⑦ User Buttons
 - Menu
 - Tech Setup
 - Set Time
 - Set Sched



Important:

The low battery indicator is displayed when the AA battery power is low. If the user fails to replace the battery within 21 days, the screen will only show the low battery indicator but maintain all functionality. If the user fails to replace the batteries after an additional 21 days (days 22-42 since first “low battery” display) the set points will change to 55°F (Heating) and 85°F (Cooling). If the user adjusts these setpoints away from these it will hold for 4 hours then return to either 55°F or 85°F. After day 42 the batteries must be replaced immediately to avoid freezing or overheating because the thermostat will shut the unit off until the battery is changed.

Product Instructions

viega

Thermostat settings

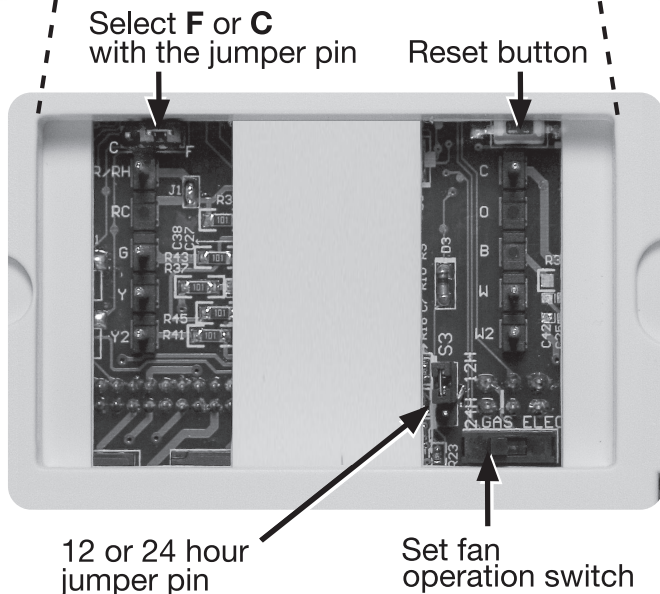
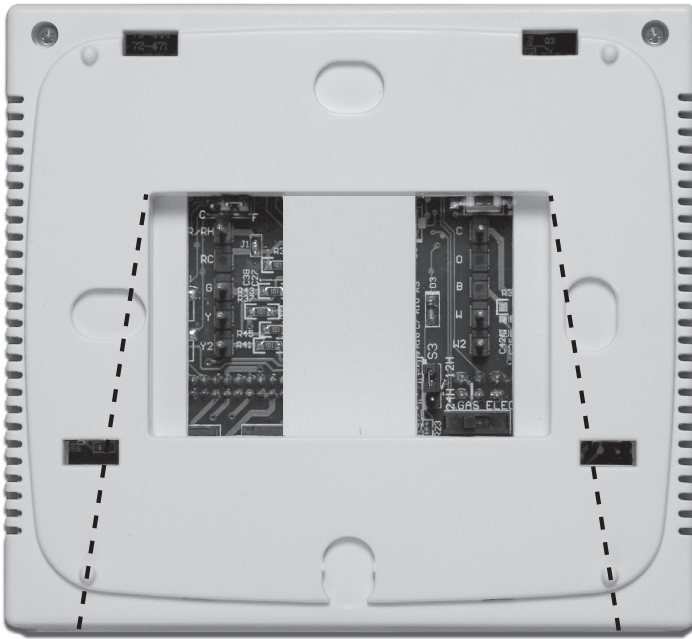

Gas or electric setup

Gas: For systems that control the fan during a call for heat, put the fan operation switch to the **GAS** position.

Electric: The fan operation switch should be put in the **ELEC** position. This setting allows the thermostat to operate the fan when the fan relay is connected to the **G** terminal.

Fahrenheit/Celsius display

Select **F** or **C** with the jumper pin on the back of the thermostat. For Fahrenheit install the jumper pin on the top two pins. For Celsius install the jumper pin on the bottom two pins.

12 or 24 hour time

12 or 24 hour (military time) can be selected with the jumper pin. For 12 hour time install the jumper pin on the top two pins. For 24 hour (military time) install the jumper pin on the bottom two pins.



Important:

The **RESET** button must be pressed after changing any switch or jumper pin setting. Batteries must be installed for this operation.

Product Instructions



Attaching the thermostat to the subbase

Align the 4 tabs on the subbase with corresponding slots on the back of the thermostat, then push gently until the thermostat snaps in place.



Battery installation

Battery installation is recommended even if thermostat is hardwired (C terminal connected). When thermostat is hardwired and batteries are installed, the thermostat will activate a compressor delay of 5 minutes when the thermostat detects a power outage from the hardwired power supply (batteries included).

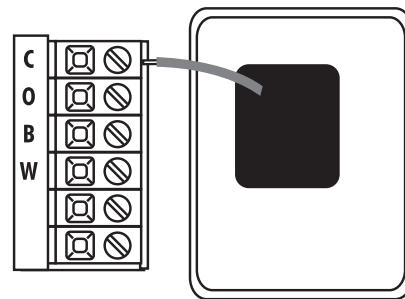

Important: High quality alkaline batteries are recommended. Rechargeable batteries or low quality batteries do not guarantee a 1-year life span.

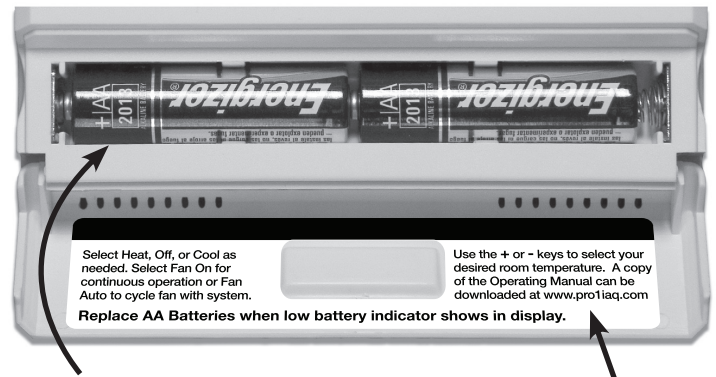

Insert 2 AA Alkaline batteries (included). High quality alkaline batteries are recommended.



Simple operating instructions are found on the back of the battery door.

Product Instructions

viega

Programming the thermostat

Adjusting the room temperature



The current room temperature is displayed in large text in the center of the thermostat under the “room temperature” heading. The set point or desired room temperature is in the upper right corner of the display under “set at”. To raise or lower the desired “set at” temperature use the red and blue  and  buttons on the top right of the thermostat.







Swing setting tip

Temperature swing, sometimes called differential or cycle rate, can be customized for this individual application. For most applications choose a swing setting that is as long as possible without making the occupants uncomfortable.

This thermostat has a technician setup menu for easy installer configuration. To setup the thermostat for your particular application:

1. Press **MENU** button.
2. Press and hold **TECH SET** button for 3 seconds. This 3 second delay is designed so that homeowners do not accidentally access the installer settings.
3. Configure the installer options as desired using the table below.

Use the  or  keys to change settings and the **NEXT STEP** or **PREV STEP** key to move from one option to another. Note: Only press **DONE** key when you want to exit the Technician Setup options.

Feature	Filter Change Reminder	Room Temperature Calibration	Minimum Compressor On Time	Compressor Short Cycle Delay	Cooling Swing	Heating Swing
Feature Description	This feature will flash "FILT" in the display after the elapsed run time to remind the user to change the filter. A setting of "off" will disable this feature	This feature allows the installer to change the calibration of the room temperature display. For example, if the thermostat reads 70° and you would like it to read 72° then select +2.	This feature allows the installer to select the minimum run time for the compressor. For example: A setting of 4 will force the compressor to run for at least 4 minutes every time the compressor turns on, regardless of the room temperature	The compressor short cycle delay protects the compressor from "short cycling". This feature will not allow the compressor to be turned on for 5 minutes after it was last turned off.	The swing setting, often called "cycle rate", "differential" or "anticipation" is adjustable. A smaller swing setting will cause more frequent cycles and a larger swing setting will cause fewer cycles.	The swing setting, often called "cycle rate", "differential" or "anticipation" is adjustable. A smaller swing setting will cause more frequent cycles and a larger swing setting will cause fewer cycles.
LCD will Show						
Adjustment Options	You can adjust the filter change reminder from "off" to 2000 hours of runtime in 50 hour increments. Tap the second button from the top left side of the thermostat to display the current filter.	You can adjust the room temperature display to read -4°F to +4°F above or below the factory calibrated reading.	You can select the minimum compressor run time from "off", "3", "4", or "5" minutes. If 3, 4, or 5 is selected, the compressor will run for at least the selected time before turning off.	Selecting "on" will not allow the compressor to be turned on for 5 minutes after the last time the compressor was on. Select "off" to remove this delay.	The cooling swing setting is adjustable from $\pm 0.2^{\circ}\text{F}$ to $\pm 2^{\circ}\text{F}$. For example: A swing setting of 0.5°F will turn the cooling on at approximately 0.5°F above the setpoint and turn the cooling off at approximately 0.5°F below the setpoint.	The heating swing setting is adjustable from $\pm 0.2^{\circ}\text{F}$ to $\pm 2^{\circ}\text{F}$. For example: A swing setting of 0.5°F will turn the heating on at approximately 0.5°F below the setpoint and turn the heating off at approximately 0.5°F above the setpoint.
Factory Default Settings	Off	0°F	Off	On	0.5°F	0.4°F

Product Instructions

viega

Programming the thermostat

Set time

Follow the steps below to set the day of the week and current time:

1. Press **MENU**.
2. Press **SET TIME**.
3. Day of the week will be flashing. Use the **+** or **-** key to select the current day of the week.
4. Press **NEXT STEP**.
5. The current hour is flashing. Use the **+** or **-** key to select the current hour. When using 12-hour time, make sure the correct a.m. or p.m. choice is selected.
6. Press **NEXT STEP**.
7. Minutes are now flashing. Use the **+** or **-** key to select current minutes.
8. Press **DONE** when completed.

All our programmable thermostats are shipped with an energy saving pre-program. You can customize this default program by following the steps below.























Your thermostat can be programmed to have all the weekdays the same, a separate program for Saturday, and a separate program for Sunday. There are four time periods for each program for each program (**WAKE, LEAVE, RETURN, SLEEP**).

Factory Default Program				
Day of the Week	Events	Time	Setpoint Temperature (Heat)	Setpoint Temperature (Cool)
Weekday	Wake	6 a.m.	70°F (21°C)	75°F (24°C)
	Leave	8 a.m.	62°F (17°C)	83°F (28°C)
	Return	6 p.m.	70°F (21°C)	75°F (24°C)
	Sleep	10 p.m.	62°F (17°C)	78°F (26°C)
Saturday	Wake	8 a.m.	70°F (21°C)	75°F (24°C)
	Leave	10 a.m.	62°F (17°C)	83°F (28°C)
	Return	6 p.m.	70°F (21°C)	75°F (24°C)
	Sleep	11 p.m.	62°F (17°C)	78°F (26°C)
Sunday	Wake	8 a.m.	70°F (21°C)	75°F (24°C)
	Leave	10 a.m.	62°F (17°C)	83°F (28°C)
	Return	6 p.m.	70°F (21°C)	75°F (24°C)
	Sleep	11 p.m.	62°F (17°C)	78°F (26°C)

Product Instructions

viega





You can use the table below to plan your customized program schedule.

Factory Default Program				
Day of the Week	Events	Time	Setpoint Temperature (Heat)	Setpoint Temperature (Cool)
Weekday	Wake  			
	Leave  			
	Return  			
	Sleep  			
Saturday	Wake  			
	Leave  			
	Return  			
	Sleep  			
Sunday	Wake  			
	Leave  			
	Return  			
	Sleep  			

Set program schedule

To customize your program schedule, follow these steps:

Weekday:

1. Select **HEAT** or **COOL** from the system switch.
NOTE: You have to program heat and cool each separately.
2. Press **MENU**.
3. Press **SET SCHED**. **NOTE:** Monday-Friday is displayed and the **WAKE** icon is shown. You are now programming the wake time period for the weekday setting.
4. Time is flashing. Use the  or  key to make your time selection for the weekday **WAKE** time period.
5. Press **NEXT STEP**.
6. The setpoint temperature is flashing. Use the  or  key to make your setpoint selection for the weekday wake period.
7. Press **NEXT STEP**.
8. Repeat steps 4 through 7 for weekday **LEAVE** time period, for weekday **RETURN** time period, and for weekday **SLEEP** time period.

Saturday:

9. Repeat steps 4 through 7 for Saturday **WAKE** time period, for Saturday **LEAVE** time period, for Saturday **RETURN** time period, and for Saturday **SLEEP** time period.

Sunday:

10. Repeat steps 4 through 7 for Sunday **WAKE** time period, for Sunday **LEAVE** time period, for Sunday **RETURN** time period, and for Sunday **SLEEP** time period.

Product Instructions



Technical data

- The display range of temperature. . . . 41°F to 95°F
(5°C to 35°C)
- The control range of temperature. . . . 44°F to 90°F
(7°C to 32°C)
- Loading Rate 1 amp per terminal,
1.5 amp maximum all
terminals combined
- Display accuracy ±1°F
- Swing (cycle rate or differential) Heating is adjustable
from 0.2°F to 2.0°F
Cooling is adjustable
from 0.2°F to 2.0°F
- Power source 18 to 30 VAC, NEC
Class II, 50/60 Hz for
hardwire (common wire)
Battery power from 2 AA
alkaline batteries
- Operating ambient. 32°F to +105°F
(0°C to +41°C)
- Operating humidity 90% non-condensing
maximum
- Dimensions of thermostat 4.7"W x 4.4"H x 0.8"D

Thermostat applications guide

Description	
Gas or Oil Heat	Yes
Electric Furnace	Yes
Heat Pump (No Aux. or Emergency Heat)	Yes
Heat Pump (with Aux. or Emergency Heat)	No
Multi-stage Systems	No
Heat Only Systems	Yes
Cool Only Systems	Yes

This document subject to updates. For the most current Viega technical literature please visit www.viega.us.
Click Services -> Click Electronic Literature Downloads -> Select Product Line -> Select Desired Document

Viega LLC, 301 N. Main, 9th Floor • Wichita, KS 67202 • Ph: 800-976-9819 • Fax: 316-425-7618