

# Product Instructions

**viega**

## Viega® Non-Programmable Heat/Cool Thermostat

The Viega non-programmable heat/cool thermostat is easy to install, easy to wire and easy to program. It can be used for single stage heating and cooling projects, making it ideal for many different applications. Installation instructions can be found below.

### Thermostat applications guide

Description	
Gas or Oil Heat	Yes
Electric Furnace	Yes
Heat Pump (No Aux. or Emergency Heat)	Yes
Heat Pump (with Aux. or Emergency Heat)	No
Multi-stage Systems	No
Heat Only Systems	Yes
Cool Only Systems	Yes

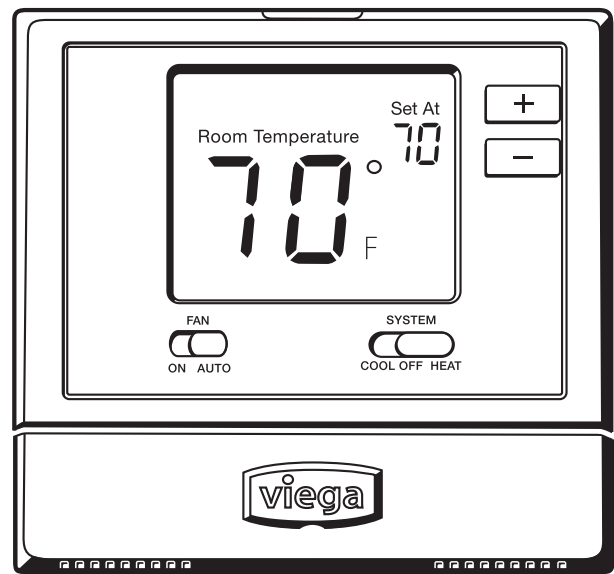

Part Number 15116

### Mounting the subbase

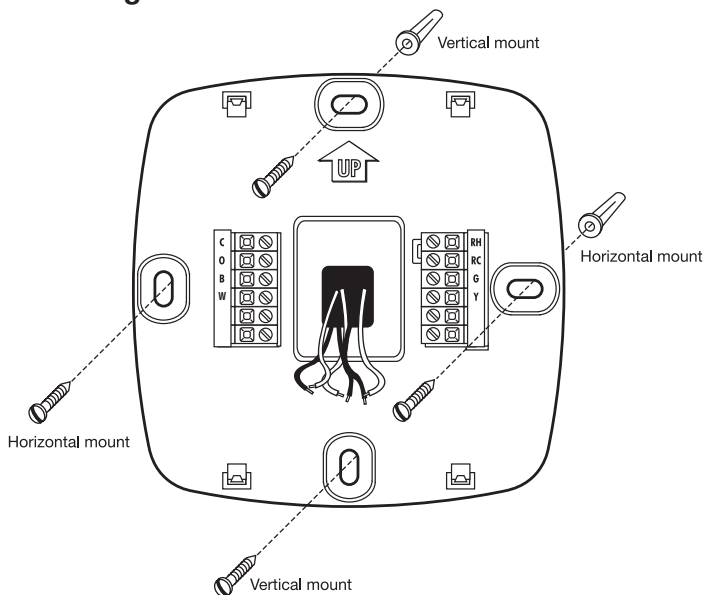

For vertical mount put one screw top and one screw bottom. For horizontal mount put one screw left and one screw right. The thermostat can be mounted directly to the wall or it can be mounted to a wall box. Use the vertical mounting screw location to attach to a wall box.

**Caution: Electrical hazard**  
 Failure to disconnect the power before beginning to install this product can cause electrical shock or equipment damage.

**Mercury notice:**  
 All of our products are mercury free. However, if the product you are replacing contains mercury, dispose of it properly. Your local waste management authority can give you instructions on recycling and proper disposal.

**A trained, experienced technician must install this product.** Carefully read these instructions. You could damage this product or cause a hazardous condition if you fail to follow these instructions.

# Product Instructions

**viega**

## Installation tips

### Wall locations

The thermostat should be installed approximately 4 to 5 feet above the floor. Select an area with average temperature and good air circulation.

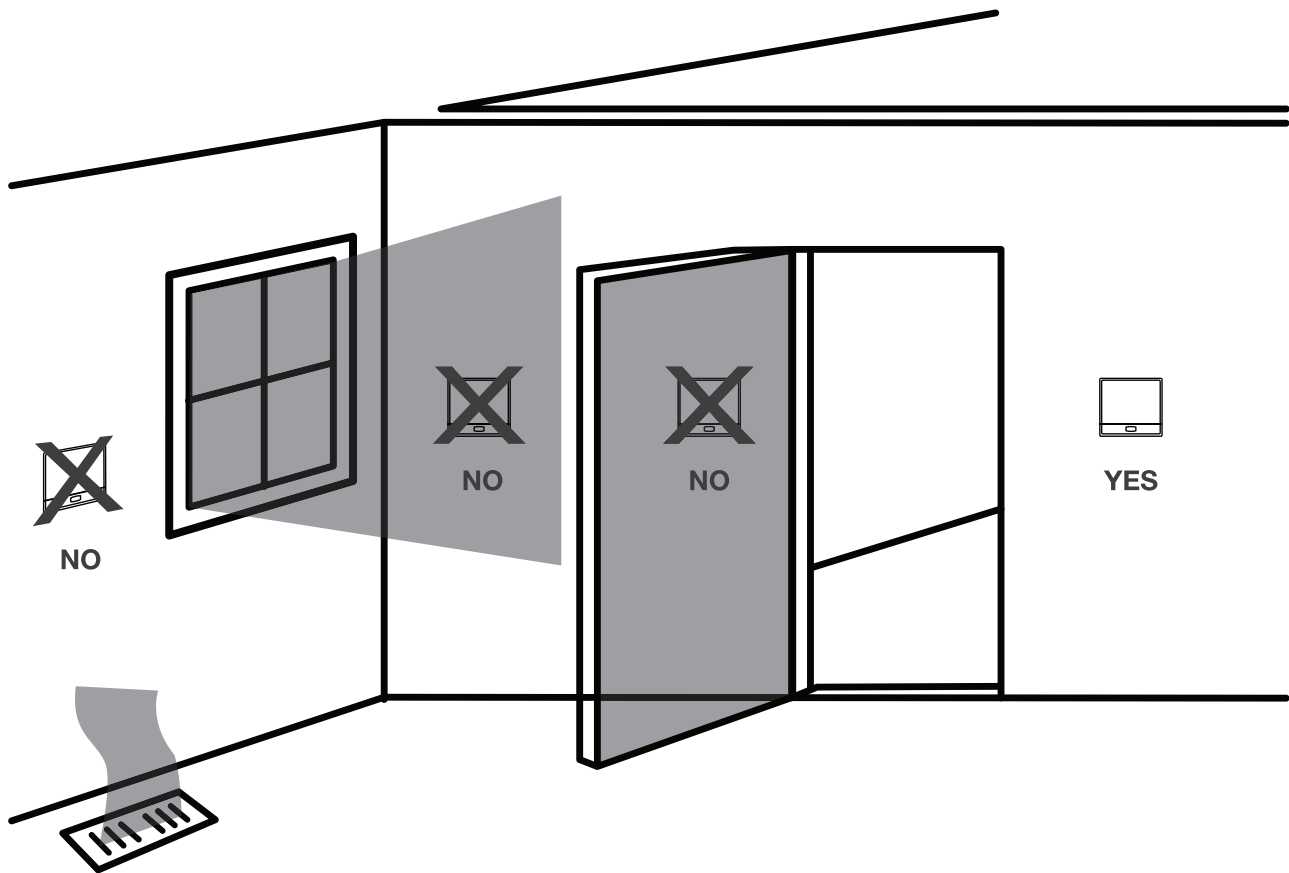

### Do not install thermostat in locations:

- Close to hot or cold air ducts
- That are in direct sunlight
- With an outside wall behind the thermostat
- In areas that do not require conditioning
- Where there are dead spots or drafts (in corners or behind doors)
- Where there might be concealed chimneys or pipes

**NOTE:** Pick an installation location that is easy for the user to access. The temperature of the location should be representative of the building

# Product Instructions

**viEGA**

## Thermostat wiring

1. If you are replacing a thermostat, make note of the terminal connections on the thermostat that is being replaced. In some cases the wiring connections will not be color coded. For example, the green wire may not be connected to the G terminal.
2. Loosen the terminal block screws. Insert wires then re-tighten terminal block screws.

## Viega thermostat terminal conversion

Thermostat	Thermostats	Zone Control	Zone Control
15118	15116	18060	18032
	15117	18062	Thermostat
		18050	18029

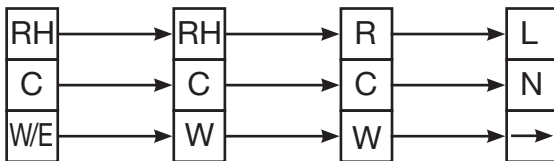

## Power type

- 3 wire
- 3 wire with battery backup
- 2 wire with battery

## Terminal designations

- W - Heat relay
- Y - Compressor relay
- G - Fan relay
- O - Heat pump changeover valve energized in cooling
- RC - Transformer power for cooling
- RH - Transformer power for heating
- B - Heat pump changeover valve energized in heating
- C - Common wire from secondary side of cooling system transformer

## Wiring tips:

### RH & RC terminals

For single transformer systems, leave the jumper wire in place between RH and RC. Remove jumper wire for two transformer systems.

### Heat pump systems

If wiring to a heat pump, use a small piece of wire (not supplied) to connect terminals W and Y.

### C terminal

The C (common wire) terminal does not have to be connected when the thermostat is powered by batteries.

### Wire specifications

Use shielded or non-shielded 18-22 gauge thermostat wire.



### Caution: Electrical hazard

Failure to disconnect the power before beginning to install this product can cause electrical shock or equipment damage.



### Warning:

All components of the control system and the thermostat installation must conform to Class II circuits per the NEC Code.

# Product Instructions

**viega**

## Typical industry wiring diagrams

- ▲ 1 Power supply
- ▲ 2 Factory-installed jumper. Remove only when installing on 2-transformer systems.
- ▲ 3 Use either O or B terminals for changeover valve
- ▲ 4 Use a small piece of wire (not supplied) to connect W and Y terminals
- ▲ 5 Set fan operation switch to electric
- ▲ 6 Optional 24 VAC common connection when thermostat is used in battery power mode

### Typical 1H/1C system: 1 transformer

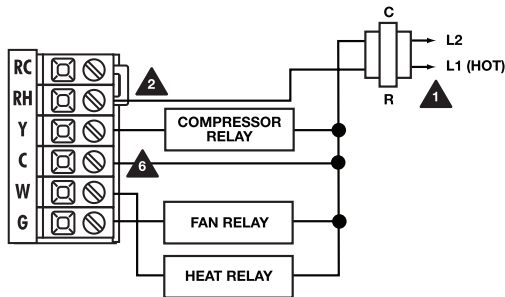

### Typical 1H/1C system: 2 transformer

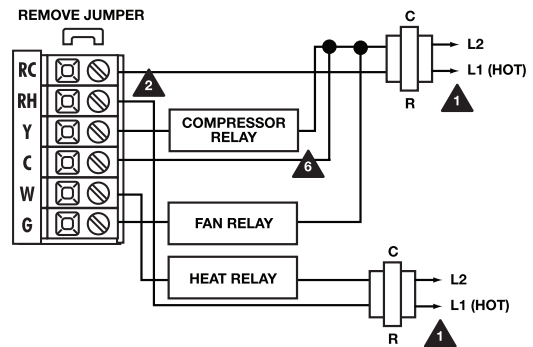

### Typical 1H/1C heat pump system

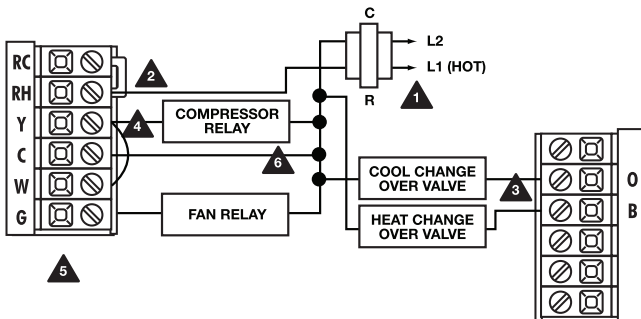

### Typical heat-only system

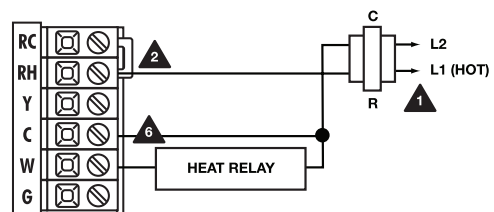

### Typical heat-only system with fan

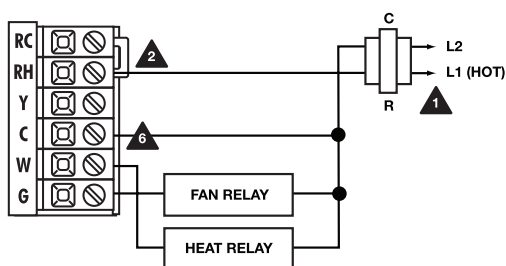

### Typical cool-only system

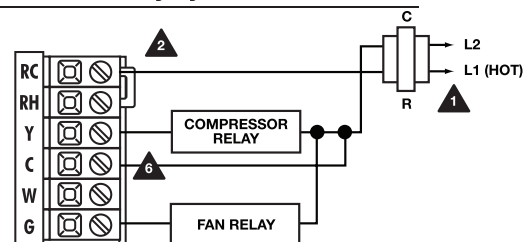

Viega LLC, 301 N. Main, 9th Floor • Wichita, KS 67202 • Ph: 800-976-9819 • Fax: 316-425-7618

# Product Instructions

**viega**

## Viega wiring diagrams

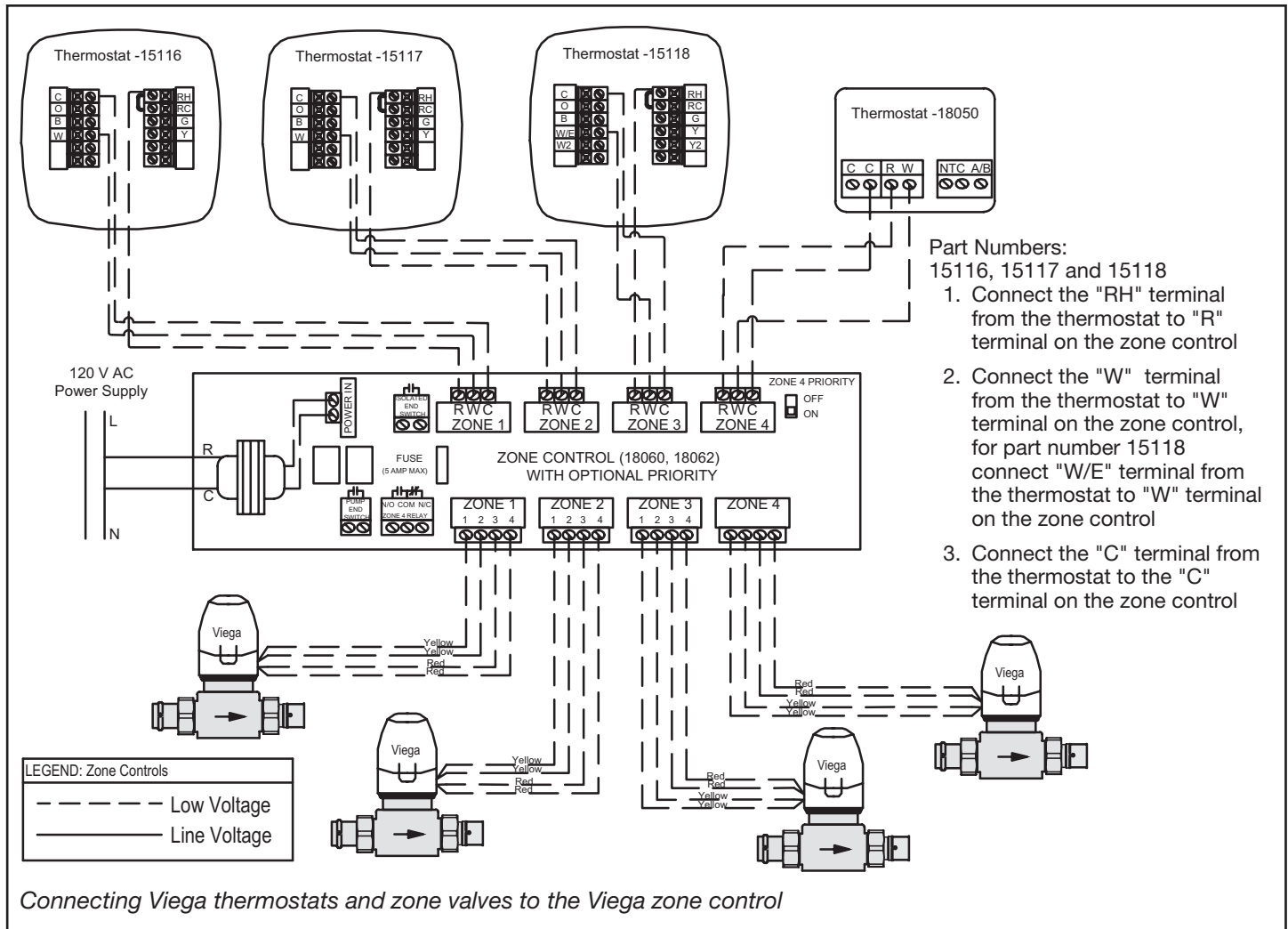

# Product Instructions

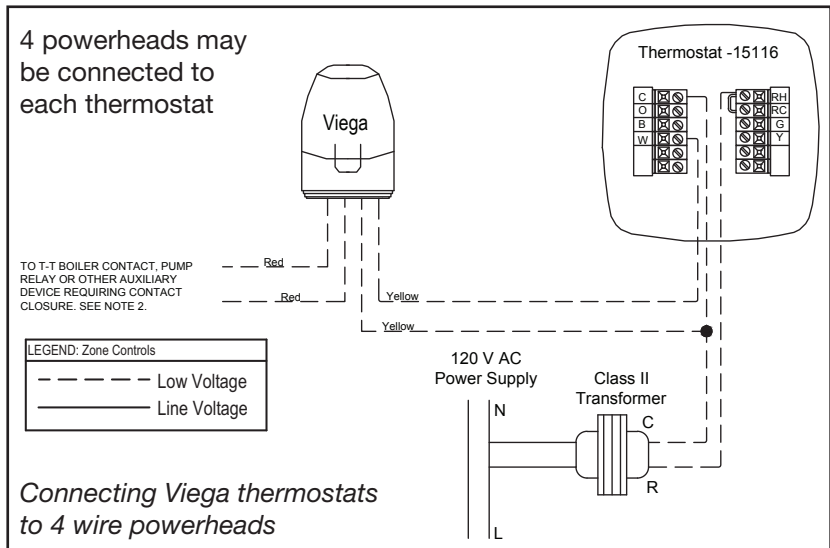
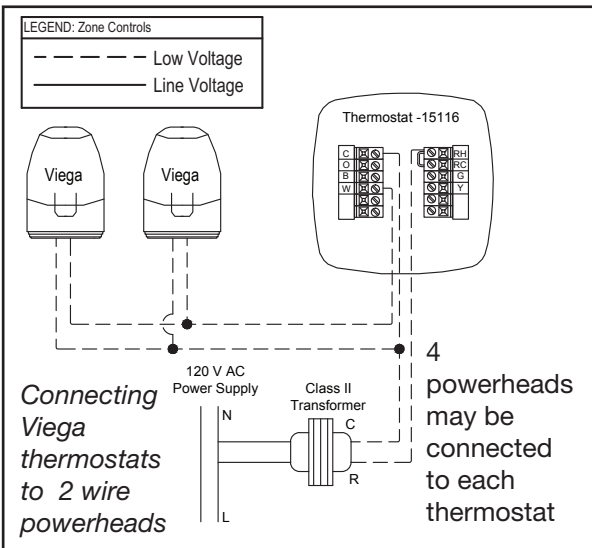
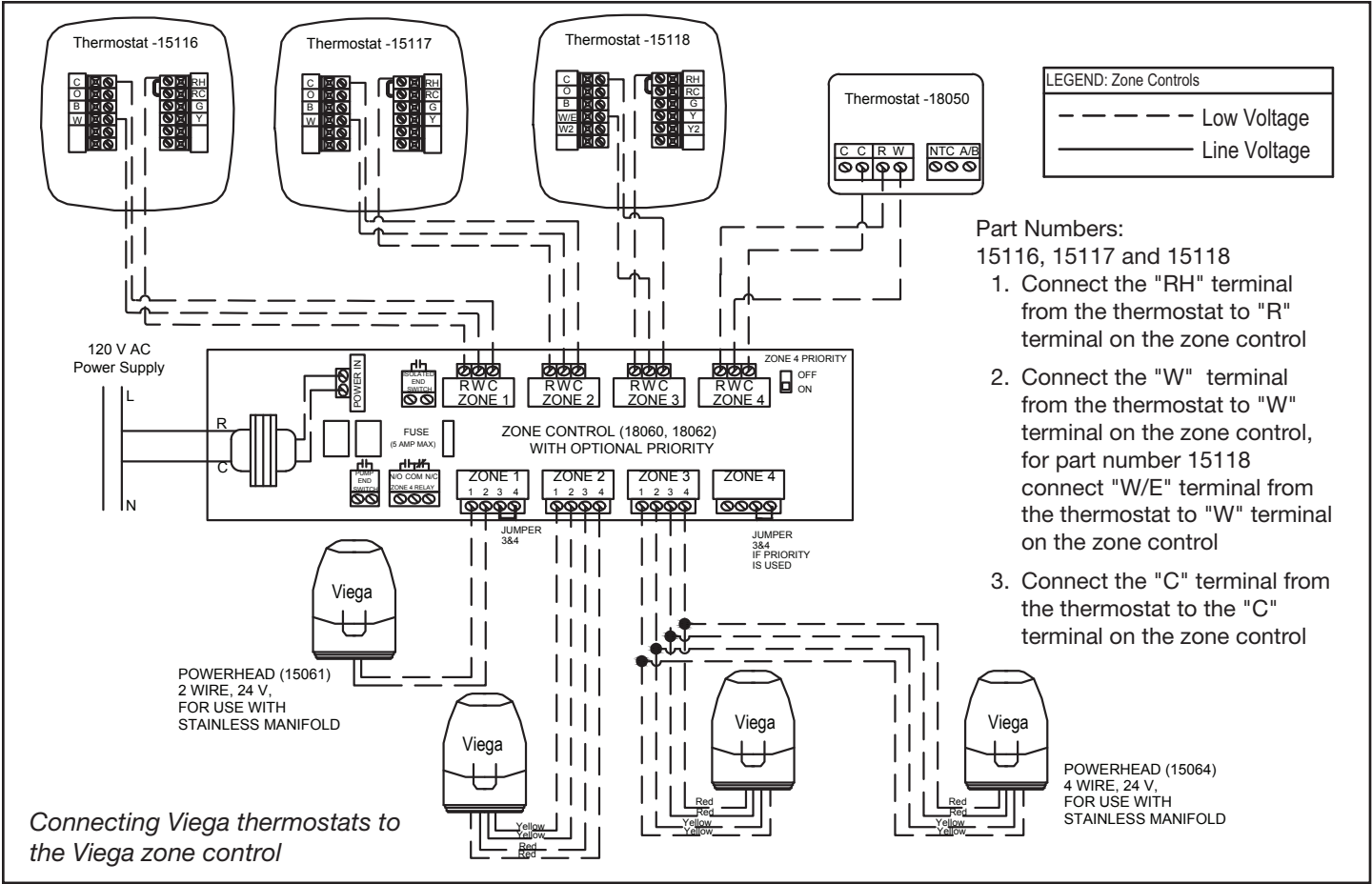

# Product Instructions

**viega**

## Thermostat display

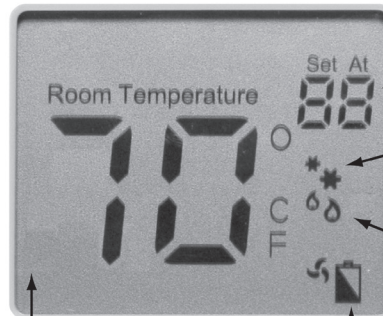
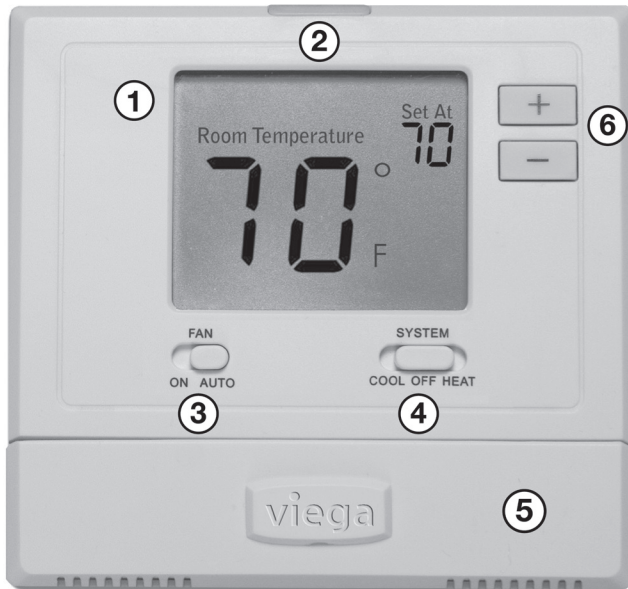

Displays the user selectable setpoint temperature.

**\*\*** **HEAT** **FAN**

System operation indicators: The **COOL**, **HEAT** or **FAN** icon will display when the **COOL**, **HEAT** or **FAN** is on.

NOTE: The compressor delay feature is active if these icons are flashing. The compressor will not turn on until the 5 minute delay has elapsed.

**Low Battery Indicator:** Replace batteries when indicator is shown.

Indicates the current room temperature.

- ① LCD
- ② Glow in the dark light button
  - Push the glow in the dark button and screen will illuminate.
- ③ Fan switch
  - Set to **AUTO** to run the fan anytime heating or cooling is running.
  - Set to **ON** to run the fan at all times.
- ④ System switch
  - Set to heating/cooling or off.
- ⑤ Easy change battery door
  - 2- AA batteries included.
- ⑥ Temperature setpoint buttons
  - Use the or buttons to adjust the room temperature.



### Important:

The low battery indicator is displayed when the AA battery power is low. If the user fails to replace the battery within 21 days, the screen will only show the low battery indicator but maintain all functionality. If the user fails to replace the batteries after an additional 21 days (days 22-42 since first "low battery" display) the set points will change to 55°F (Heating) and 85°F (Cooling). If the user adjusts these setpoints away from these it will hold for 4 hours then return to either 55°F or 85°F. After day 42 the batteries must be replaced immediately to avoid freezing or overheating because the thermostat will shut the unit off until the battery is changed.

# Product Instructions

**viega**

## Thermostat settings

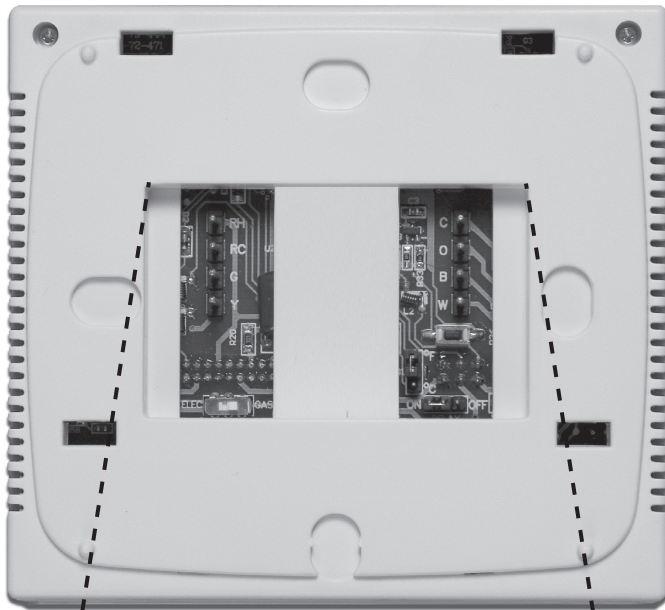

Select **ELEC** or **GAS** with this switch

Reset button

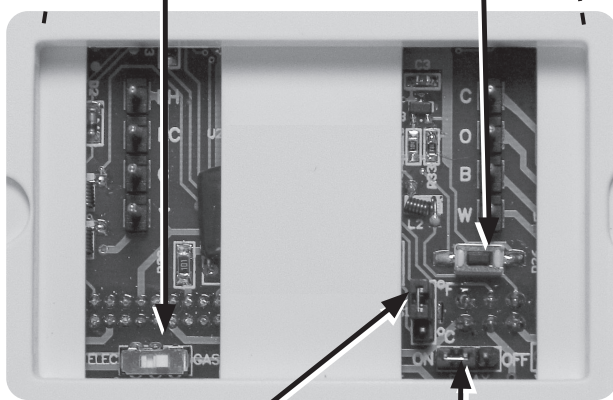

Select **F** or **C** with the jumper pin

Select delay **ON** or **OFF** with the jumper pin

## Gas or electric setup

**Gas:** For systems that control the fan during a call for heat, put the fan operation switch to the **GAS** position.

**Electric:** The fan operation switch should be put in the **ELEC** position. This setting allows the thermostat to operate the fan when the fan relay is connected to the **G** terminal.

## Fahrenheit/Celsius display

Select **F** or **C** with the jumper pin on the back of the thermostat. For Fahrenheit install the jumper pin on the top two pins. For Celsius install the jumper pin on the bottom two pins.

## Delay

The compressor delay will not allow the compressor to be turned on for 5 minutes after the last time the compressor was on. The cooling icon will flash during the delay period. Select **OFF** or **ON** with the jumper pin as desired. For **ON** install the jumper pin on the two pins to the left, for **OFF** install the jumper pin on the two pins to the right.



### Important:

The **RESET** button must be pressed after changing any switch or jumper pin setting. Batteries must be installed for this operation.

# Product Instructions

**viega**

## Attaching the thermostat to the subbase

Align the 4 tabs on the subbase with corresponding slots on the back of the thermostat, then push gently until the thermostat snaps in place.



**Important:** The low battery indicator is displayed when the AA battery power is low. If the user fails to replace the battery within 21 days, the screen will only show the low battery indicator but maintain all functionality. If the user fails to replace the batteries after an additional 21 days (days 22-42 since first “low battery” display) the set points will change to 55°F (Heating) and 85°F (Cooling). If the user adjusts these setpoints away from these it will hold for 4 hours then return to either 55°F or 85°F. After day 42 the batteries must be replaced immediately to avoid freezing or overheating because the thermostat will shut the unit off until the battery is changed.

## Battery installation

Battery installation is recommended even if thermostat is hardwired (C terminal connected). When thermostat is hardwired and batteries are installed, the thermostat will activate a compressor delay of 5 minutes when the thermostat detects a power outage from the hardwired power supply (batteries included).

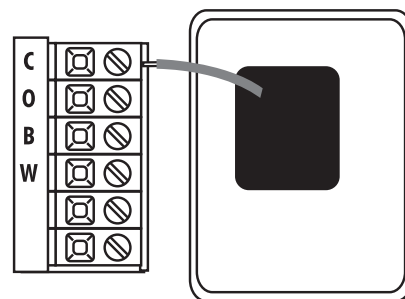

**Important:** High quality alkaline batteries are recommended. Rechargeable batteries or low quality batteries do not guarantee a 1-year life span.

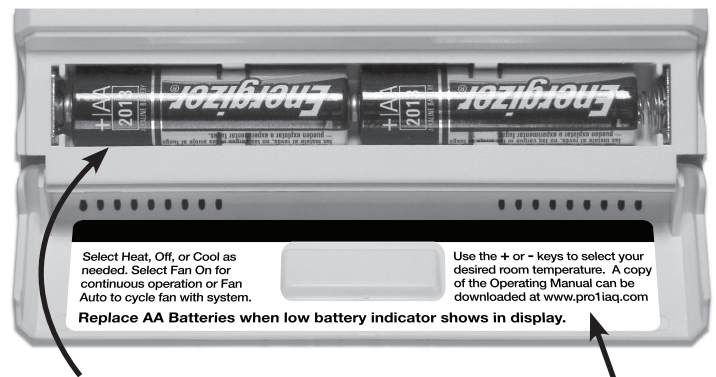

Insert 2 AA Alkaline batteries (included). High quality alkaline batteries are recommended.



Simple operating instructions are found on the back of the battery door.

# Product Instructions

viEGA





## Programming the thermostat

### Adjusting the room temperature

The current room temperature is displayed in large text in the center of the thermostat under the “room temperature” heading. The set point or desired room temperature is in the upper right corner of the display under “set at”. To raise or lower the desired “set at” temperature use the red and blue  and  buttons on the top right of the thermostat.





### Adjusting the temperature swing

The swing setting, often called **CYCLE RATE**, **DIFFERENTIAL** or **ANTICIPATION** is adjustable. A smaller swing setting will cause more frequent cycles and a larger swing setting will cause fewer cycles. There are separate swing settings for heat and for cool. Follow the steps below to adjust the **SWING** setting for heat or cool:

1. Select HEAT or COOL with the system switch.
2. Hold down the  or  keys together for 3 seconds.
3. Use the  or  key to adjust the swing. The swing is adjustable from  $\pm 0.2^{\circ}\text{F}$  to  $\pm 2^{\circ}\text{F}$ . For example: A swing setting of  $0.5^{\circ}\text{F}$  will turn the cooling on at approximately  $0.5^{\circ}\text{F}$  above the setpoint and turn the cooling off at approximately  $0.5^{\circ}\text{F}$  below the setpoint. The factory default for cooling is  $0.5^{\circ}\text{F}$  and  $0.4^{\circ}\text{F}$  for heating.
4. Wait approximately 10 seconds for the thermostat to return to normal operation.

## Room temperature calibration

This feature allows the installer to change the calibration of the room temperature display. For example: If the thermostat reads  $70^{\circ}$  and you would like it to display  $72^{\circ}$  then select +2. You can adjust the room temperature display to read  $-4^{\circ}\text{F}$  to  $+4^{\circ}\text{F}$  above or below the factory calibrated reading. Follow the steps below to adjust the temperature reading:

1. Select OFF with the system switch.
2. Hold down the  and  keys together for 3 seconds.
3. Use the  or  key to adjust the room temperature display.
4. Wait approximately 10 seconds for the thermostat to return to normal operation.

## Swing setting tip

Temperature swing, sometimes called differential or cycle rate can be customized for this individual application. For most applications choose a swing setting that is as long as possible without making the occupants uncomfortable.

# Product Instructions

**viega**



## Technical data

The display range of temperature. . . 41°F to 95°F  
(5°C to 35°C)

The control range of temperature. . . 44°F to 90°F  
(7°C to 32°C)

Loading Rate . . . . . 1 amp per terminal,  
1.5 amp maximum all  
terminals combined

Display accuracy . . . . . ±1°F

Swing (cycle rate or differential) . . . Heating is adjustable  
from 0.2°F to 2.0°F  
Cooling is adjustable  
from 0.2°F to 2.0°F

Power source . . . . . 18 to 30 VAC, NEC  
Class II, 50/60 Hz for  
hardwire (common wire)  
Battery power from 2 AA  
alkaline batteries

Operating ambient. . . . . 32°F to +105°F  
(0°C to +41°C)

Operating humidity . . . . . 90% non-condensing  
maximum

Dimensions of thermostat . . . . . 4.7"W x 4.4"H x 0.8"D

## Thermostat applications guide

Description	
Gas or Oil Heat	Yes
Electric Furnace	Yes
Heat Pump (No Aux. or Emergency Heat)	Yes
Heat Pump (with Aux. or Emergency Heat)	No
Multi-stage Systems	No
Heat Only Systems	Yes
Cool Only Systems	Yes

This document subject to updates. For the most current Viega technical literature please visit [www.viega.us](http://www.viega.us).  
Click Services -> Click Electronic Literature Downloads -> Select Product Line -> Select Desired Document

**Viega LLC, 301 N. Main, 9th Floor • Wichita, KS 67202 • Ph: 800-976-9819 • Fax: 316-425-7618**