

TECHNICAL SPECIFICATIONS FOR MODEL UWS

COMMERCIAL/INDUSTRIAL LOW-STATIC AXIAL FAN HYDRONIC UNIT HEATER

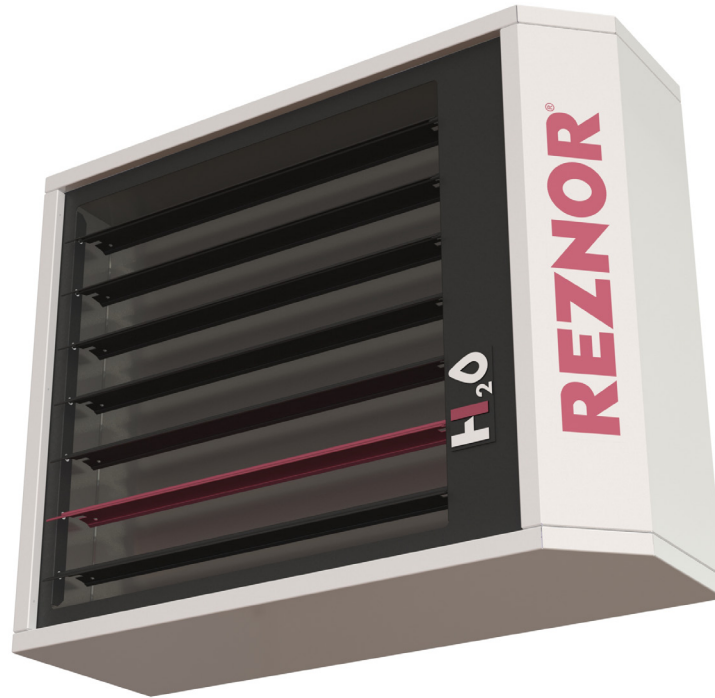

Table of Contents

Unit Sizes	2
Features	2
Field-Installed Options	2
Technical Data	2
Certification	3
Installation Codes	3
Unit Location	4
Mounting Height	4
Dimensions	5
Weights	6
Clearances	6
Piping Connections	6
Electrical Connections	7

In keeping with our policy of continuous product improvement, we reserve the right to alter, at any time, the design, construction, dimensions, weights, etc., of equipment information shown here.

TECHNICAL SPECIFICATIONS—CONTINUED

Unit Sizes

These heaters are available in nine unit sizes based on 10,000–191,000 BTUh input.

Features

- 115/1/60 voltage/phase/Hz
- Optimized for 140°F entering water temperature
- Copper tube/aluminum fin coil for medium temperature water and low pressure steam applications
- Vertical or horizontal air delivery
- Painted galvanized-steel cabinet with two-toned black and white glossy, scratch-resistant paint scheme
- Multi-speed fan for tailored air delivery and quiet operation
- Two-point (for horizontal discharge) or four-point (for downward discharge) suspension standard on all unit sizes

Field-Installed Options

Option	Description
CD1	Vertical louvers, direct discharge air to provide wider throw pattern
CD2	Downturn nozzle, 25- to 65-degree variable air deflection range
CD3	Downturn nozzle, 50- to 90-degree variable air deflection range
CD4	Downturn nozzle, 25- to 65-degree variable air deflection range with vertical louvers
CD5	Downturn nozzle, 50- to 90-degree variable air deflection range with vertical louvers
CL5	Single-stage thermostat
CM1	Locking cover for CL1 thermostat
CM3	Bracket assembly for mounting thermostat on unit
CN3F	Remote ON/OFF switch in 2 × 4 box

Technical Data

Parameter	Unit of Measure	Unit Size (MBTUh)								
		10/15	15/21	22/31	32/45	44/62	62/77	83/104	110/137	159/191
Heating capacity (low speed)	BTUh	10,000	15,000	22,000	32,000	44,000	62,000	83,000	110,000	159,000
	kW	2.9	4.4	6.4	9.4	12.9	18.2	24.3	32.2	46.6
Heating capacity (high speed)	BTUh	15,000	21,000	31,000	45,000	62,000	77,000	104,000	137,000	191,000
	kW	4.4	6.2	9.1	13.2	18.2	22.6	30.5	40.2	56.0
Nominal water flow rate (low speed)	GPM	1.2	1.5	2.5	3.2	4.8	6.4	8.4	11.3	17.8
Nominal water flow rate (high speed)		1.5	2.1	2.9	4.5	6.0	7.9	10.4	14.0	22.0
Minimum water flow rate		0.9	1.2	1.6	2.6	3.4	4.5	5.9	8.0	12.5
Maximum operating pressure	psi	150								
	bar	10								
	kPa	1034								
Maximum operating temperature	°F	250								
	°C	121								
Minimum water temperature	°F	40								
	°C	4.4								
Entering water temperature	°F	140								
	°C	60								
Exiting water temperature	°F	120								
	°C	49								

Parameter	Unit of Measure	Unit Size (MBTUh)								
		10/15	15/21	22/31	32/45	44/62	62/77	83/104	110/137	159/191
Discharge air temperature rise (low speed)	°F	33		44	49	35	40	49	46	44
Discharge air temperature rise (high speed)		39	34	47	51	38	42	55		
Air volume (low speed)	CFM	248	524	417	620	1094	1404	1371	2200	3800
	meter ³ /hour	421.4	890.3	708.5	1053.4	1858.7	2385.4	2329.3	3737.8	6456.2
Air volume (high speed)	CFM	410	569	636	793	1659	1820	2054	2805	4147
	meter ³ /hour	696.6	966.7	1080.6	1347.3	2818.6	3092.2	3489.7	4765.7	7045.8
Air velocity (low speed)	FPM	331	359	334	372	394	383	343	435	534
	meter/min	101	110	102	113	120	117	104	133	163
Air velocity (high speed)	FPM	547	390	509	476	597	496	514	555	583
	meter/min	167	119	155	145	182	151	157	169	178
Discharge air opening area	feet ²	0.75	1.46	1.25	1.67	2.78	3.67	4.00	5.06	7.11
	meter ²	0.07	0.14	0.12	0.15	0.26	0.34	0.37	0.47	0.66
Sound level @ 10 feet (low speed)	dBa	63	57	60	58	58	61	63	71	73
Sound level @ 10 feet (high speed)		59	55	57	52	51	57	58	62	64
Water connection size, male NPT	inch	3/4		1-1/4					1-1/2	
Full load amps, 115V	amp	0.96		1.67			3.4		7.3	
Maximum overcurrent protection		15								
Minimum current ampacity		1.2		2.09			4.25		9.1	
Fan motor size (TEFC)	HP	0.08			0.05		0.25		0.50	
Fan motor speed	RPM	1550			1050					
Fan diameter	inch	10		12	16	18	20		24	

Certification

These unit heaters are listed by Intertek for use in the US and Canada at elevations up to 10,000 feet (3,000 meters).

Installation Codes

- These units must be installed in accordance with local building codes. Local authorities having jurisdiction should be consulted before installation is made to verify local codes and installation procedure requirements.
- All electrical wiring and connections, including electrical grounding MUST be made in accordance with the *National Electric Code* (ANSI/NFPA No. 70, latest edition) or, in Canada, the *Canadian Electric Code* (Part 1, CSA C.22.1). In addition, the installer should be aware of any local ordinances that might apply.

TECHNICAL SPECIFICATIONS—CONTINUED

Unit Location

⚠ CAUTION ⚠

Do not locate the heater where it may be exposed to water spray, rain, or dripping water.

For best results, the heater should be located with certain rules in mind:

- Heaters should always be arranged to blow toward or along exposed wall surfaces, if possible. Where two or more heaters are installed in the same room, a general scheme of air circulation should be maintained for best results.
- Suspended heaters are most effective when located as close to the working zone as possible, and this fact should be kept in mind when determining the mounting heights to be used. However, care should be exercised to avoid directing the discharged air directly on the room occupants.
- Partitions, columns, counters, or other obstructions should be taken into consideration when locating the heater so that a minimum quantity of airflow will be deflected by such obstacles.
- When heaters are located in the center of the space to be heated, the air should be discharged toward the exposed walls. In large areas, heaters should be located to discharge air along exposed walls with extra units provided to discharge air in toward the center of the area.

Mounting Height

⚠ WARNING ⚠

If touched, the internal heater surfaces that are accessible from outside the heater will cause burns. Suspend the heater a minimum of 5 feet (1.6 meters)—for unit sizes 10/15–44/62—or 8 feet (2.5 meters)—for unit sizes 62/77–159/191—above the floor.

In general, the heater should be located 6–14 feet (1.8–4.3 meters) above the floor. At those points where infiltration of cold air is excessive, such as at entrance doors and shipping doors, it is desirable to locate the heater so that it will discharge directly toward the source of cold air from a distance of 15–20 feet (4.6–6.1 meters).

Unit Size (MBTUh)	
10/15, 15/21, 22/31, 32/45, 44/62	62/77, 83/104, 110/137, 159/191
Accessibility to General Public	
Accessible	Non-Accessible
Minimum Mounting Height (Feet (Meters))	
5 (1.6)	8 (2.5)

Dimensions

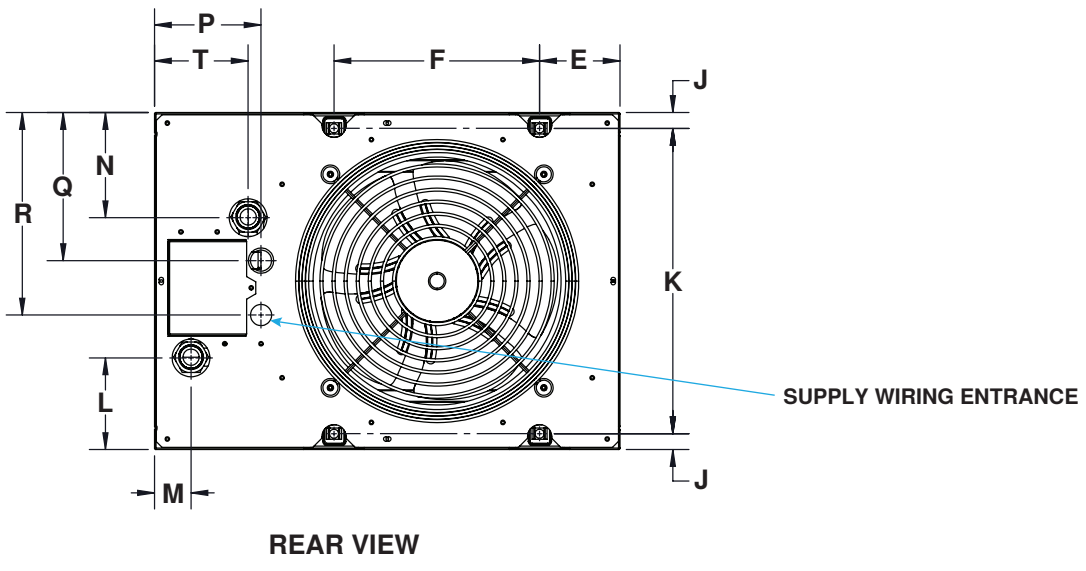
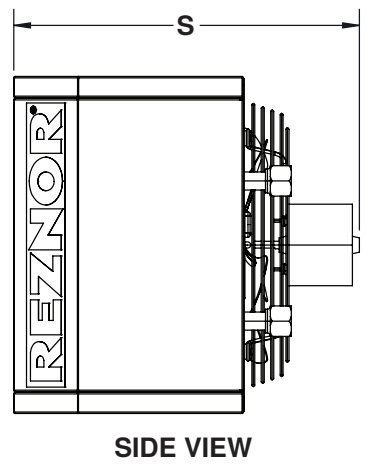
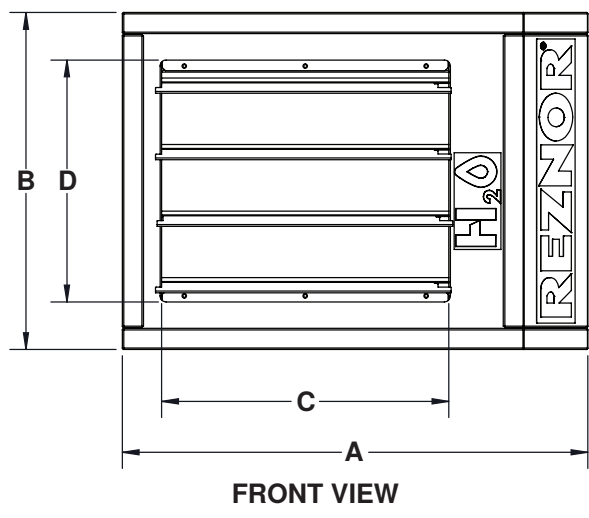
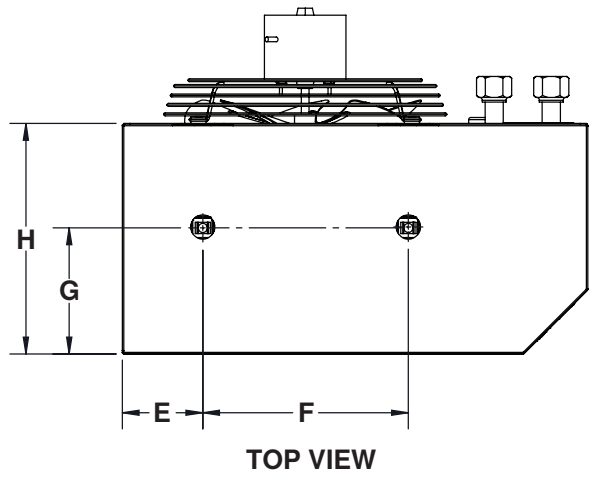

TECHNICAL SPECIFICATIONS—CONTINUED

Dimensions—Continued

Dimension*	Unit Size (MBTUh)								
	10/15	15/21	22/31	32/45	44/62	62/77	83/104	110/137	159/191
	Inches (mm)								
A	19-1/4 (489)	23-3/4 (603)	24-3/4 (629)	28-3/4 (730)	32-3/4 (832)	38 (965)	41-1/2 (1054)		
B	19-15/16 (506)	17-1/16 (433)	20 15/16 (532)	23-7/16 (595)	27-7/16 (697)	29-7/16 (748)	35-7/16 (900)		
C	12 (305)	15 (381)		20 (508)	22 (559)	24-1/8 (613)	28 (711)	32 (813)	
D	10 (254)	12-7/8 (327)			17 (432)	23-7/8 (606)	24 (610)	26 (660)	31-13/16 (808)
E**	3-5/16 (84)	4-1/16 (103)	4-9/16 (116)	3-9/16 (90)	4-9/16 (116)			7-9/16 (192)	
F**	8-1/2 (216)	10 (254)	11 (279)	16 (406)		18 (457)	22 (559)	20 (508)	
G	5-1/4 (133)	5-15/16 (151)		6-1/8 (156)	8 (203)				
H	9-1/2 (241)			11-5/8 (295)					
J	1/2 (13)	3/4 (19)	11/16 (17)	13/16 (21)	11/16 (17)				
K**	12-1/4 (311)	15-5/8 (397)		9-5/16 (237)	22 (559)	26 (660)	28 (711)	34 (864)	
L***	3-1/2 (89)	2-5/8 (67)	5-5/8 (143)	3-7/8 (98)	3-15/16 (100)	3-15/16 (100)	3-15/16 (100)	4-15/16 (125)	
M***	1-5/32 (29)	3 (76)	1-7/8 (48)				1-7/8 (48)	3-1/16 (78)	2-15/16 (75)
N***	4-5/16 (110)	8-3/4 (222)	7-1/16 (179)	6-7/8 (175)	3-7/16 (87)	4-15/16 (125)	3-15/16 (100)	5-15/16 (151)	
P	4 (102)	5 (127)	4-5/8 (117)		5-1/2 (140)	5-3/4 (146)	6-1/2 (165)	5-3/4 (146)	
Q	6-1/8 (156)	3-1/2 (89)	2-1/4 (57)	11-1/16 (281)	9-1/4 (235)	11-1/4 (286)	12-1/4 (311)	15-1/4 (387)	
R	7-15/16 (202)	5-3/4 (146)	4-1/2 (114)	13-5/16 (338)	14-1/4 (362)	16-1/4 (413)	17-1/4 (438)	20-1/4 (514)	
S	14 (356)	16-11/16 (424)	16-9/16 (421)	18-5/8 (473)	17-5/8 (448)	19-13/16 (503)	20-5/8 (524)	20-13/16 (529)	
T**	3-1/2 (89)	5-3/8 (137)	5 (127)	1-13/16 (46)	5-1/16 (129)	7-1/16 (179)	5 (127)	6-1/4 (159)	2-3/4 (70)

*See graphic above.
 **Heater suspension points (3/8-16 FEM).
 ***Piping entrance points.

Weights

Unit Size (MBTUh)								
10/15	15/21	22/31	32/45	44/62	62/77	83/104	110/137	159/191
Pounds (kg)								
30 (14)	39 (18)	43 (20)	52 (24)	66 (30)	88 (40)	91 (42)	117 (54)	142 (65)

Clearances

Units must be installed so that the clearances are provided for with regards to inspection and service and for proper spacing from combustible construction. Clearance to combustibles is defined as the minimum distance from the heater to a surface or object for which it is necessary to ensure that a surface temperature of 90°F (50°C) above the surrounding ambient temperature is not exceeded.

Heater Surface	Minimum Clearance (Inches (mm))
Top, bottom, sides	0 (0)
Rear (from fan motor)	18 (457)

Piping Connections

⚠ WARNING ⚠

- Maximum operating pressure is 150 psi (10 bar, 1,034 kPa). Maximum water temperature is 250°F (121°C). Minimum water temperature is 40°F (4.4°C).
- Flange seals must not be made with rubber or other material that melts easily. In the event of overheated water, rubber seals may melt.
- Mount a thermostatic air vent if the distribution ring of the water or steam is in a lower position than the heater.

Connect inlet and outlet piping using approved pipe sealant as shown below.

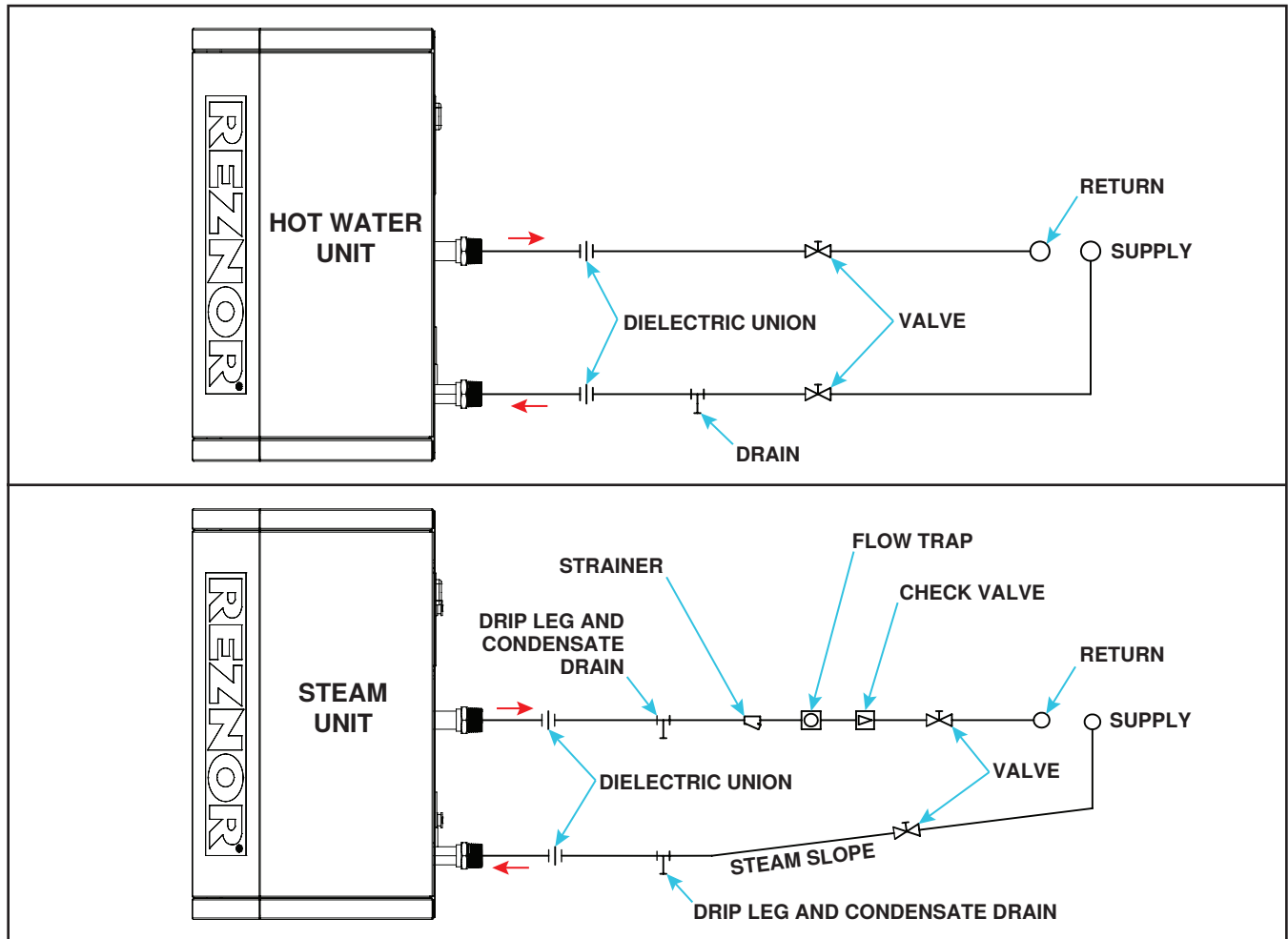

Electrical Connections

⚠ CAUTION ⚠

- Ensure that all wiring is in accordance with the wiring diagram provided with the unit.
- All electrical wiring and connections, including electrical grounding **MUST BE** made in accordance with the *National Electric Code* (ANSI/NFPA No. 70, latest edition) or, in Canada, the *Canadian Electric Code* (Part 1, CSA C.22.1). In addition, the installer should be aware of any local ordinances that might apply.
- All external wiring must be within approved conduit and have a minimum temperature rise rating of 140°F (60°C). Conduit must be run so as not to interfere with the heater access panel.

⚠ WARNING ⚠

- This appliance is not intended for use by persons with reduced physical, sensory, or mental capabilities or lack of experience and knowledge, unless they have been given supervision or instruction concerning use of the appliance by a person responsible for their safety.
- Children should be supervised to ensure that they do not play with the appliance.
- Do not store or use gasoline or other flammable vapors and liquids in the vicinity of this or any other appliance.
- Do not remove safety labels. If they are unreadable, contact an authorized distributor for replacement labels.
- The heat exchanger coils must be protected against freezing.

For more information on Reznor HVAC products:

- Contact your local Reznor representative at 1-800-695-1901
- Refer to the manuals and additional consumer materials found at www.reznorhvac.com

