

# RESCUE® EZ13 ECM Blower Motor

## Installation and Troubleshooting Manual

For technical assistance or questions  
related to your RESCUE® EZ13 Motor  
call the hotline at  
1-888-540-5540

Read the entire manual prior to installation of the  
RESCUE® EZ13 Motor.  
Follow all instructions contained herein.

***Nidec***  
All for dreams

M018206190000



# Table of Contents

<b>Important Safety Information</b> .....	<b>1</b>
<b>RESCUE EZ13 Motor</b> .....	<b>3</b>
Key Features and Benefits .....	3
Specifications .....	3
Dimensions .....	3
General Information.....	4
Materials Enclosed .....	4
Initial Inspection.....	4
Handling and Care.....	4
Motor Installation.....	5
Step 1: Turn OFF Electrical Power .....	5
Step 2: Remove the Blower Housing from the HVAC Equipment.....	5
Step 3: Locate and Verify the Connector .....	6
Step 4: Remove the Original ECM Motor .....	6
Step 5: Install the Replacement Motor in the Belly-Band.....	7
Step 6: Install the Replacement Motor in the Air Handling Unit .....	8
Step 7: Reinstall the Blower Assembly in the HVAC System .....	8
Motor Start-Up and Operation .....	8
Operating Mode Checklist .....	9
Final Checks .....	9
<b>Maintenance</b> .....	<b>10</b>
<b>Troubleshooting</b> .....	<b>11</b>
<b>Warranty Information</b> .....	<b>12</b>

# Important Safety Information



## WARNING

- Read all instructions thoroughly and be familiar with the equipment before installing or working on it.
- Only trained and qualified professionals familiar with RESCUE® EZ13 motors should service the motor and control unit.
- Before connecting or disconnecting cables or other electrical connections, verify that the electrical power to the system is removed. Failure to comply may cause serious damage to the motor or HVAC system or injury.
- Because of the risk of electric shock, only individuals thoroughly trained in the use of multimeters should conduct voltage tests.
- Never touch the metal contacts on the multimeter during a test.
- Always check testing equipment for proper operation before use.

## WARNING

Installation, operation, and maintenance must be performed by qualified personnel. Familiarization with and adherence to the National Electrical Code (NEC) and National Fire Protection Association (NFPA) standards and to local codes are required. It is important to observe safety precautions to protect personnel from possible injury. Personnel should be instructed for handling each of the following:

- Insulate all connections carefully to prevent grounding or short circuits. Reinstall all conduit and terminal box covers. To avoid overheating or loss of performance, voltage to the motor control unit must be within plus or minus 10% of the nameplate voltage.
- Make sure the unit is electrically grounded and that proper electrical installation, wiring, and controls are used consistent with local and national electric codes. Refer to **NEC Handbook** and **NFPA No. 70**. Employ qualified electricians for the installation and maintenance of the unit.
- Code requirements differ from state to state. Install equipment using qualified electricians in accordance with the applicable codes and ordinances in your area and in accordance with NEC. All electrical connections should be made and maintained by a qualified or licensed electrician.
- Make sure there are no unusual noises or vibrations when the motor is running.
- Avoid contact with energized circuits or rotating parts.
- Provide proper safeguards for personnel against rotating parts.
- All aspects of the installation must conform to the applicable requirements of the NEC, including **Article 430 (Motor Circuits and Controllers)**, as well as all local codes.

 **WARNING**

- Always disconnect electrical power at the fuse box or circuit breaker panel before handling electrical connections or performing maintenance on this unit. Allow the motor to come to a complete stop and wait four (4) minutes. This allows the capacitors to discharge any residual voltage for safety.
- Double-check to make sure that electrical power is removed and that it cannot be turned on while you are working on the equipment.
- A poor electrical connection can overheat and cause terminal and/or terminal board failures. Examine the wiring harness quick-connect terminals carefully for any signs of physical deterioration or loose fit to the terminals on the motor terminal board.
- If there is evidence of deterioration or loose fit, remove the quick-connect terminals from the wiring harness and then connect the harness wires directly to the motor terminal board wiring terminals.
- Care must be taken to assure connections are made to the proper terminals and adequate electrical clearances are maintained.
- The control unit on the motor contains hazardous voltage.

 **CAUTION**

- Wear safety glasses to inspect the equipment while it is running or while working on equipment.

**NOTICE**

The motor and control unit are assembled and calibrated as a set. Replacing either the motor or control unit with other unsuitable parts could drastically affect performance tolerance.

- To prevent permanent damage to the unit, only apply nameplate voltage.
- **Do not** apply 230 Vac to the motor when the motor is configured for 115 Vac operation. Refer to **page 7**.
- **Do not** strike the motor shaft with a hammer or other tool as this may damage the bearings.
- **Do not** operate the motor without the blower wheel attached. Without the blower wheel attached, the motor will run continuously to a maximum speed and then stop.
- Voltage symbols vary among different multimeters and may be displayed as Vac, AC, V, or a V beneath a wavy line. Select the correct symbol and set the multimeter to the voltage closest to but higher than the voltage you are measuring.
- The RESCUE® EZ13 motor is properly packaged for shipment and storage and should be kept in a clean and dry indoor area.

# RESCUE® EZ13 Motor

The RESCUE® EZ13 EMC Blower Motor is a high efficiency variable speed replacement motor for Electronic Commutated Motor (ECM) applications. This motor enables the homeowner to enjoy many of the benefits of variable speed motors.

## Key Features and Benefits

- Dual voltage
- Multi-speed operations with five 24 volt taps
- Auto rotation sensing technology
- No programming required
- Ready to install

## Specifications

- **Horsepower:** 1, 3/4, 1/2-1/3 HP
- **Voltage:** 1Ø, 115/208-230 Vac
- **Speed:** 1050 RPM
- **Hertz:** 60 or 50
- **Frame:** NEMA® 48
- **Mounting:** Belly-band

## Dimensions

All dimensions are for reference only.

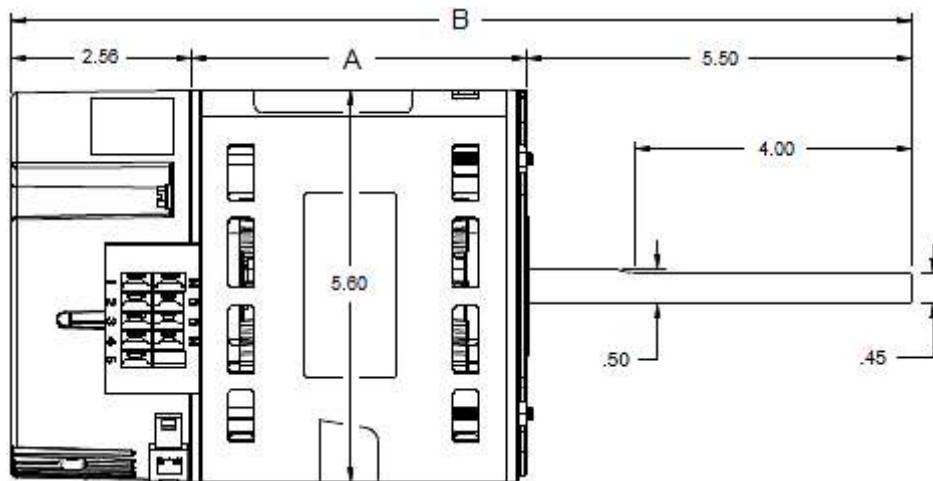

HP	Dim. A	Dim. B
1	4.79	12.85
3/4	4.41	12.47
1/2-1/3	4.16	12.22

## General Information

### Materials Enclosed

- RESCUE® EZ13 Motor
- RESCUE® EZ13 Motor Installation and Troubleshooting Manual
- RESCUE® EZ13 Accessory Components (Wiring Harness and 115V Plug)

### Initial Inspection

Check the RESCUE® EZ13 motor to verify the following:

- The shaft spins freely by hand.
- The nameplate information conforms to the specifications of the motor ordered.

#### NOTICE

The RESCUE® EZ13 motor may look visually different than the motor it is replacing. The external appearance is not an exact replica of the motor it is replacing. However, when properly installed, the motor will fit in the blower housing and function according to specifications.

### Handling and Care

The motor should be stored indoors in a clean, dry location. Proper selection, installation, and maintenance will assure longer life and more dependable service.

#### WARNING

Use only specially designed motors where explosive atmospheric hazards exist. See the ***National Electrical Code (NEC) Article 500*** or check with local codes for explanation of hazardous or classified atmospheres and locations. Unless the motor is specifically marked “ELECTRIC MOTOR FOR HAZARDOUS LOCATIONS,” it is not suitable for use in Class I or II hazardous locations as defined by the NEC.

#### NOTICE

Use motors only in the applications for which they are designed.

- The RESCUE® EZ13 motor is designed for direct-drive centrifugal blower applications only.
- The RESCUE® EZ13 motor is designated for continuous, air-over duty, and must be mounted in the air stream of an air moving device, such as a fan. **Do not** operate the RESCUE® EZ13 motor outside of the air stream as that may overheat and damage the motor.
- Temperature around the motor should not exceed 104°F (40°C) or be less than -20°F (-29°C).

# Motor Installation



- Always disconnect electrical power at the fuse box or circuit breaker panel before handling electrical connections or performing maintenance on this unit. Allow the motor to come to a complete stop and wait four (4) minutes. This allows the capacitors to discharge any residual voltage for safety.
- Double-check to make sure that electrical power is removed and that it cannot be turned on while you are working on the equipment.
- A poor electrical connection can overheat and cause terminal and/or terminal board failures. Examine the wiring harness quick-connect terminals carefully for any signs of physical deterioration or loose fit to the terminals on the motor terminal board.

## Step 1: Turn OFF Electrical Power

These instructions provide field technicians a guide for installing a RESCUE® EZ13 motor and are intended for a typical air handler/furnace equipment system. These instructions **do not** override or replace instructions by the HVAC system manufacturer.

1. Turn **OFF** electric power to the HVAC unit at the disconnect or the main service panel before making any electrical connections.

## Step 2: Remove the Blower Housing from the HVAC Equipment

1. Disconnect the furnace wiring harness from the motor.
2. Remove the blower housing from the air handling unit. Refer to the manufacturer's installation manual for blower removal instructions.

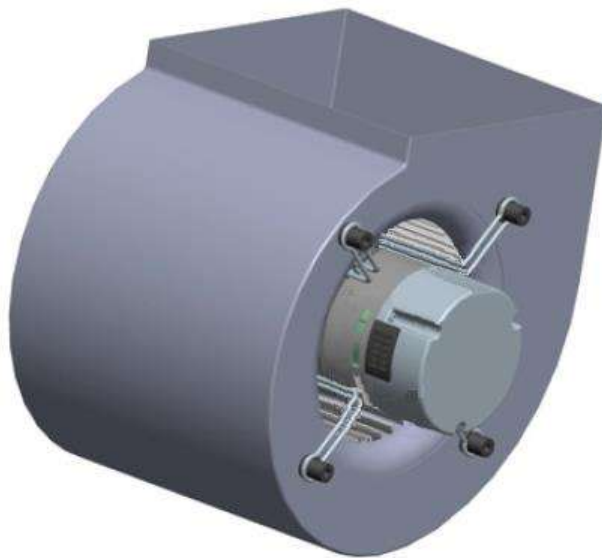

### Step 3: Locate and Verify the Connector

1. Connect the furnace wiring harness to the RESCUE® EZ13 replacement motor to ensure proper fit.
2. Disconnect the furnace wiring harness from the new motor and set it aside.

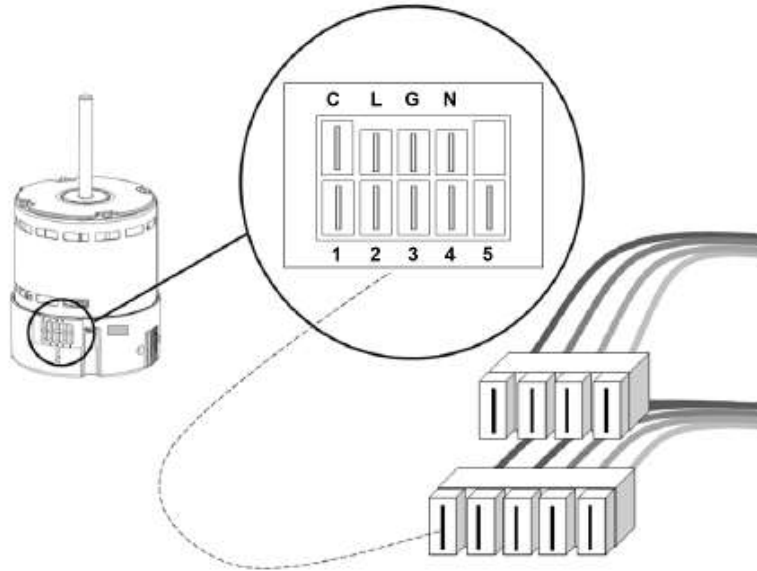

### Step 4: Remove the Original ECM Motor

1. Loosen the set screw on the motor shaft.
2. Remove the screw that secures the belly-band mounting bracket to the original motor and set aside.
3. Remove the original motor from the mounting bracket.
4. Verify that the RESCUE® EZ13 motor has the same horsepower and voltage rating as the original ECM motor.

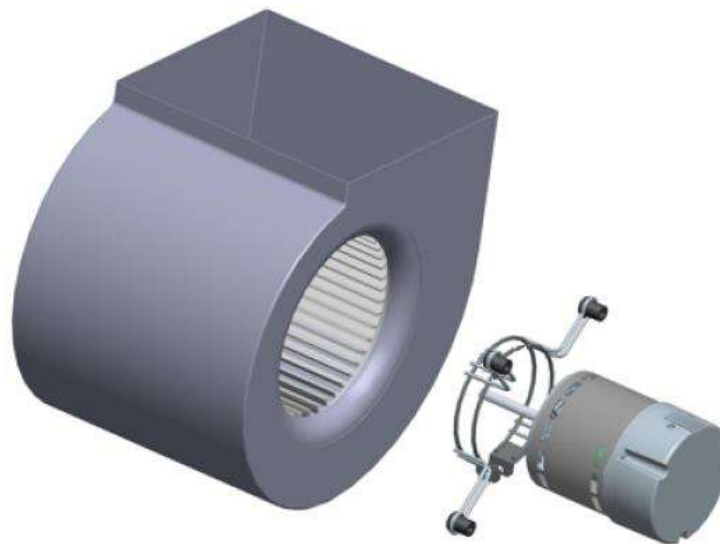

## Step 5: Install the Replacement Motor in the Belly-Band

1. Ensure that the voltage on the motor matches that of the replaced ECM motor. The RESCUE® EZ13 motor ships connected for **208-230 Vac** systems. No action is needed in the case of a 208-230 Vac requirement.

### NOTICE

- If **115 Vac** is required, change the voltage on the RESCUE® EZ13 motor using the mating connector located to the right of the control connector.
- Flip open the plastic door marked **230V** and remove the plastic door.
- Locate the **115V plug** in the bag of accessory components and insert the 115V plug into the mating connector. Make sure the 115V plug is pressed firmly into the mating connector. Without the 115V plug, the motor will not start.
- Operating the motor at 230 Vac with the 115V plug installed into the connector will cause significant damage to the motor.



115 Vac System



230 Vac System

2. Insert the RESCUE® EZ13 motor into the mounting bracket. The belly-band can be positioned anywhere on the motor shell except on the end bell (control). The preferred position is at the midpoint between the vents.

### NOTICE

- The RESCUE® EZ13 motor can be installed with the mounting bracket from the original ECM motor. If a replacement bracket is needed, contact your authorized U.S. Motors® distributor.
- Placing the belly-band on the control housing can damage the motor.

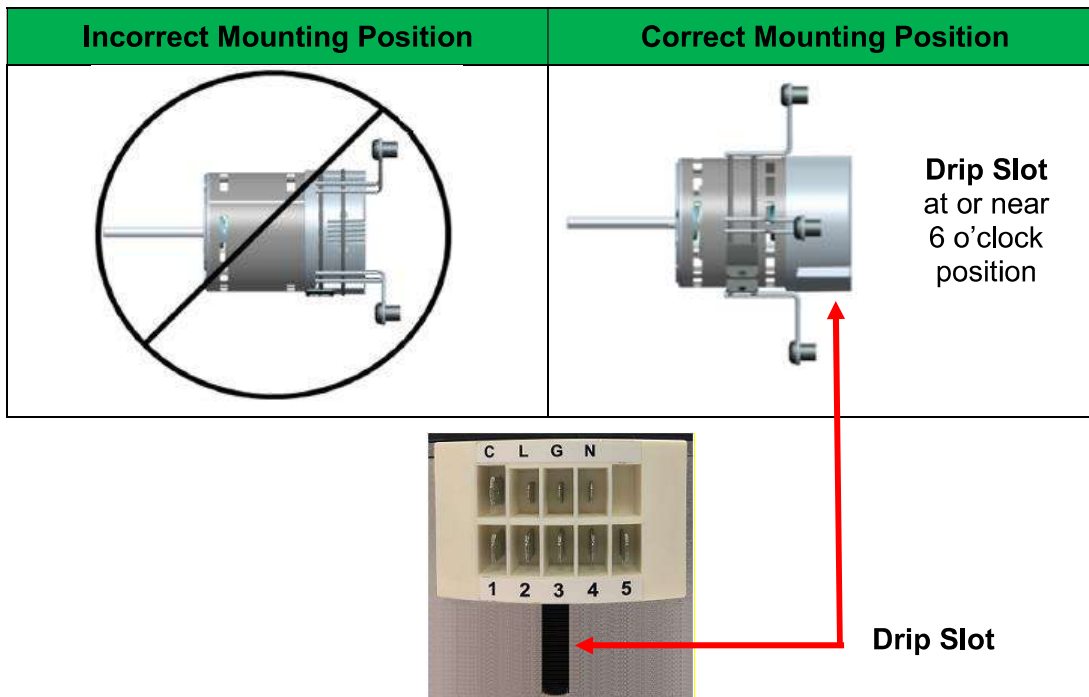

3. When mounting the motor and control into the belly-band ensure that the **Drip Slot** is positioned at or near a 6 o'clock position to allow any condensation build-up to drain from the motor.

4. Secure the bracket to the motor by tightening the bracket mounting screw.

## NOTICE

- The motor must be securely fastened to minimize noise and prevent vibration. Ensure the bell-band legs cannot be moved. For secure mounting, use high-quality bolts of the largest possible diameter.

### Step 6: Install the Replacement Motor in the Air Handling Unit

1. Insert the motor shaft into the blower wheel, securing the motor to the blower housing.



2. Align the blower wheel so it is properly centered in the blower housing, aligning the wheel's set screw to the flat of the motor shaft.
3. Secure the blower wheel to the motor shaft by tightening the set screw to a torque setting of **157 in-lbs.**

### Step 7: Reinstall the Blower Assembly in the HVAC System

1. Follow the manufacturer's installation manual for blower installation instructions.
2. Connect the furnace wiring harness to the replacement motor.

## Motor Start-Up and Operation

The first time the RESCUE® EZ13 motor is powered on and receives a run signal from the system control board, it performs a rotation sensing process. The motor runs for approximately 20 seconds in each direction to determine the proper direction for the application. Once the motor determines the proper operating direction, the information is stored and the motor does not require the process for subsequent run signals. In the event of system power loss exceeding 60 seconds, the rotation sensing process is re-initiated at the next run signal after power is restored. If the motor is unable to sense the proper rotation, the motor uses default rotation, which is counter-clockwise.

**⚠ WARNING**

- Electric Shock Hazard! The motor must be properly grounded through the furnace wiring harness.
- Be careful when touching the exterior of an operating motor. It may be hot enough to cause serious injury. This condition is normal for most motors when operated at rated load and voltage.

A motor should not be operated under conditions that cause the motor protection mode to run continually. A motor that operates continually in motor protection mode may be overloaded, or the supply voltage or frequency may be incorrect.

Actual operating speed is determined by the load applied. In general, if a motor is properly sized and connected to its load, a detectable speed difference will be noted when different speed taps are energized. When operating without a load, however, a motor may run continuously to a maximum speed. Then stop and restart operation.

## Operating Mode Checklist

**⚠ WARNING**

- For air moving applications, all enclosure covers and panels must be in place before measuring the amperage.
- Voltage and moving parts around motors and motor driven equipment can cause serious or fatal injuries. Turn **OFF** electrical power before connecting or servicing the motor.

After installation, motor operation should be tested in all system modes for the following:

Check #	System Test	Description
1	Start-Up and Shut-Off Delays	Once the motor is powered <b>ON</b> , it is normal for a RESCUE® EZ13 motor to experience a 10-12 second delay before beginning operation and may take 30-255 seconds before reaching full speed. When the motor is turned <b>OFF</b> , it is normal for the motor to experience a 30-255 second delay before turning <b>OFF</b> .
2	Unusual Noise or Vibration	If unusual noise or vibration is detected, refer to the <b>Troubleshooting</b> section on <b>page 11</b> .
3	Motor Amperage	Amperage reading at the highest speed setting should be within 10% of the specification shown on the nameplate.
4	Air Flow	Verify that the correct airflow is present in all operating modes.

## Final Checks

- Check the mounting and fastening of both the motor and the control. Make sure the motor and control are securely attached together and mounted tightly in HVAC system.
- Check the wiring harness. Inspecting for shorts and detached wiring. Ensure that the wiring harness is securely connected to the control connector.
- Check the wiring harness and signal connections. Make sure both are securely connected to the control connectors.
- Check the blower motor and verify wheel rotation. Make sure it spins freely manually without effort or assisted means in both directions.
- Verify that the set screw on the blower wheel is securely tightened.
- Check that the circuit breaker is **ON**.

# Maintenance



Before performing any maintenance on the RESCUE® EZ13 motor, disconnect electrical power and allow the motor to come to a complete stop. For safety, wait four (4) minutes. This allows sufficient time for the capacitors to discharge any residual voltage.

- Periodically inspect the installation. Check for dirt accumulation, unusual noises or vibration, overheating, worn or loose couplings, high motor amps, poor wiring or overheated connections, loose mounting bolts or guards, and worn motor starter contacts. Check the wiring harnesses and control connectors. Inspect for shorts, detached wiring, or loose connections.
- Remove dirt accumulation, particularly in and around vent openings by vacuuming. Dirt accumulation can cause motor overheating and is a fire hazard.
- **Do not** use solvents! Some solvents may attack motor insulation, finish, or bearing lubricants. Solvents are highly flammable.
- Ball bearing motors are permanently lubricated. No maintenance is required.

# Troubleshooting

Symptom	Corrective Action
Motor is not spinning or runs abnormally	<ul style="list-style-type: none"><li>• Verify that the thermostat is issuing a call for activity.</li><li>• Check the circuit breaker for trips or accidental shutoff.</li><li>• Verify that the wiring harnesses are securely connected to the control connectors.</li><li>• Inspect for shorts or detached wiring.</li><li>• Inspect the control for broken or loose connectors, moisture, excessive dirt, or other damage.</li></ul>
Motor rattles or makes excessive noise	<ul style="list-style-type: none"><li>• Inspect the motor and blower for accumulated dirt, internal debris, or other signs of damage.</li><li>• Inspect the blower fan for bent or missing blades, misaligned shaft, or unsecured mounting to the shaft.</li><li>• Inspect the blower housing for cracks, dents, or corrosion.</li><li>• Inspect the blower housing for secure mounting to the system chassis.</li><li>• Inspect the shaft and verify that the motor shaft spins freely without effort or assisted means in both directions.</li></ul>

For Technical Assistance call the  
RESCUE® EZ13 Hotline:  
1-888-540-5540

# Warranty Information

## LIMITED WARRANTY

Nidec Motor Corporation (NMC) extends the following LIMITED WARRANTY to the purchaser and to its customers (collectively referred to as the "Purchaser") of the enclosed motor and components: the motor and components are free from defects in materials and workmanship under normal use, service and maintenance FOR A PERIOD OF 24 MONTHS FROM THE DATE OF ORIGINAL PURCHASE FROM NMC OR THE NMC DEALER/RETAILER, NOT TO EXCEED 30 MONTHS FROM THE DATE OF MANUFACTURE BY NMC. THE FOREGOING WARRANTY IS THE ONLY WARRANTY GIVEN AND NO OTHER WARRANTY IS PROVIDED, EXPRESS OR IMPLIED, INCLUDING WITHOUT LIMITATION, MERCHANTABILITY OR FITNESS FOR A PARTICULAR PURPOSE. Certain aspects of disclaimers are not applicable to consumer products, i.e., motors and components acquired by individuals and used for personal, family or household purposes (as distinguished from industrial or other purposes). Some states do not allow limitations on how long an implied warranty lasts, so the above limitation may not apply to you. This warranty gives you specific legal rights, and you may have other rights which vary from state to state.

Certain repairs or services are the responsibility of the Purchaser and the Purchaser is expected to pay for them. This warranty does not extend to any losses or damages due to misuse, accident, abuse, neglect, negligence, unauthorized modification or alteration, use beyond rated capacity, or improper installation, maintenance, application or use, including, without limitation, use in a manner contrary to the accompanying instructions or applicable codes.

If within thirty (30) days after Purchaser's discovery of any warranty defects within the above stated warranty period, Purchaser notifies NMC or the dealer from whom the motor was purchased in writing, NMC shall, at its option and as Purchaser's exclusive remedy, repair or replace or refund the purchase price for that portion of the motor and components found by NMC to be defective. Failure by Purchaser to give such written notice within the applicable time period shall be deemed an absolute and unconditional waiver of Purchaser's claim for such defects. Purchaser must write or call the dealer from whom the motor was purchased for directions regarding the shipment of the motor, with freight prepaid by the Purchaser, to an authorized service location for warranty service. If Purchaser is unable to contact the dealer to obtain sufficient instructions regarding the handling of the motor, Purchaser should write NMC at the address below, giving the motor model number, the dealer's name, address and number of dealer's invoice; and describing the nature of the alleged defect. Arrangements for warranty service will then be made by NMC.

If the motor is damaged in transit, Purchaser should file a claim directly with the carrier.

IN NO EVENT, REGARDLESS OF THE FORM OF THE CLAIM OR CAUSE OF ACTION (WHETHER BASED IN CONTRACT, INFRINGEMENT, NEGLIGENCE, STRICT LIABILITY, OTHER TORT OR OTHERWISE), SHALL NIDEC'S LIABILITY TO PURCHASER OR ITS CUSTOMER EXCEED THE PRICE PAID BY PURCHASER FOR THE SPECIFIC MOTOR OR OTHER GOODS PROVIDED BY GIVING RISE TO THE CAUSE OF ACTION. IN NO EVENT SHALL NIDEC'S LIABILITY TO PURCHASER OR ITS CUSTOMER EXTEND TO INCLUDE INCIDENTAL CONSEQUENTIAL OR PUNITIVE DAMAGES. WITH RESPECT TO CONSUMER PRODUCTS, SOME STATES DO NOT ALLOW THE EXCLUSION OR LIMITATION OF INCIDENTAL OR CONSEQUENTIAL DAMAGES, SO THE ABOVE LIMITATION OR EXCLUSION MAY NOT APPLY TO YOU.

## Notes

© 2019 Nidec Motor Corporation. All rights reserved. U.S.  
Motors® and RESCUE® EZ13 are registered trademarks of Nidec  
Motor Corporation.

**For more information**  
Visit us at [www.nidec-motor.com](http://www.nidec-motor.com)

Nidec Motor Corporation  
8050 W. Florissant Avenue  
PO Box 36912  
St. Louis, MO 63136

***Nidec***  
**All for dreams**

