

Long Life EOS Analyzer

INSTRUCTION MANUAL

ENGLISH

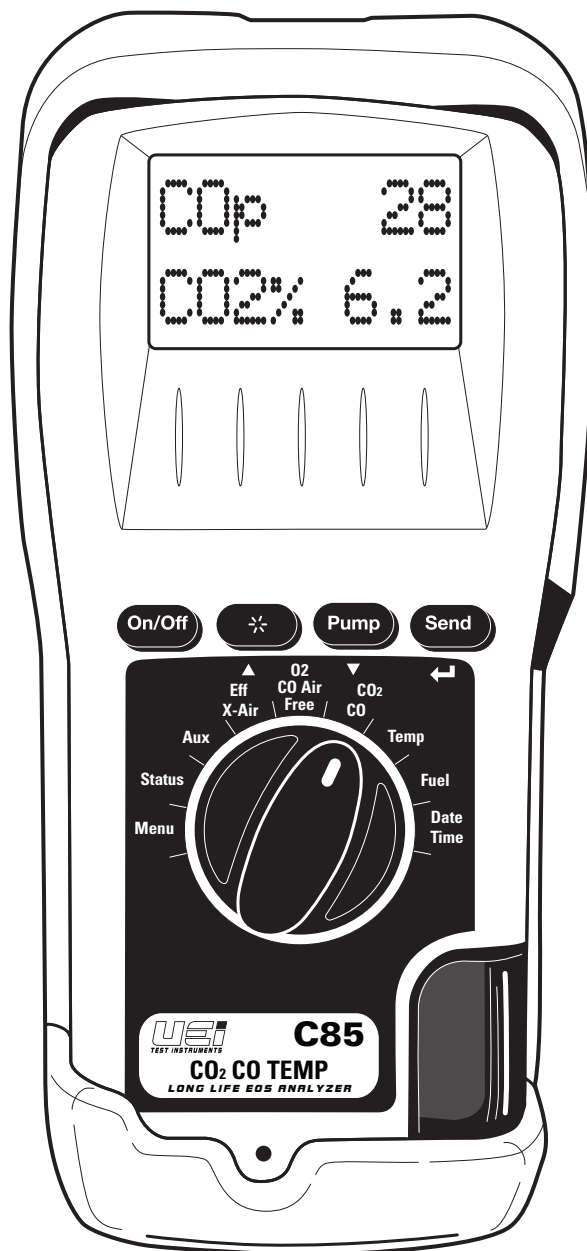

TABLE OF CONTENTS

Display Symbols	2	Where To Test	10-11
Analyzer Overview	3	What Results Are Generally Acceptable	11
Getting Started	4	General Maintenance	12
Safety Notes	4	Pre Test Checklist	12
Warnings	4	Setting Inlet Temperature	12
Menu / Setup	4	Analyzer Connections	12
Set Time	4	Emptying, Cleaning Water Trap	12
Set Date	4	Changing Particle Filter	12
Set Auxiliary Screen	5	Replacing Batteries	13
Adjust Screen Contrast	5	Post Test	13
Customizeable Header (on print-outs)	6	Periodic Service	13
Set Language	6	Analyzer Re-Certification	13
Viewing and Printing Reports	7	Cleaning	13
Print Setup	7	Other Important Factors Related To Combustion	14
Basic Fast Start (Operation)	8	Combustion Measurement Terms	14
Power On	8	Specifications	15
Select Fuel	8	Electromagnetic Compatibility	15
Connect Probe	8	Limited Warranty	16
Select Parameter to View / Log / Print	8		
Status	8		
Aux	8		
Eff- X Air	9		
O2 CO Air Free	9		
CO2 CO	9		
Temp	9		
Fuel	9		
Date Time	9		

DISPLAY SYMBOLS

λ	Excess Air	Theoretical amount of air in excess of level needed to completely burn fuel
ΔT	Delta T	Differential temperature
Δ	Losses	Losses calculated from oxygen and type of fuel
T_i	Inlet Temperature	Temperature measured and stored to calculate efficiency
T_f	Flue Temperature	Temperature measured by the flue probe or accessory k-type thermocouple
R	Ratio	CO to CO2 Ratio. Used to indicate the general condition of the combustion process
CO_F	Carbon Monoxide	Carbon Monoxide measure in parts per million ppm
$CO_2\%$	Carbon Dioxide	Carbon Dioxide measured in percentage%
$O_2\%$	Oxygen	Oxygen calculated
Eff_G	Efficiency	Calculated combustion efficiency based on net temperature, oxygen and fuel selected

ANALYZER OVERVIEW

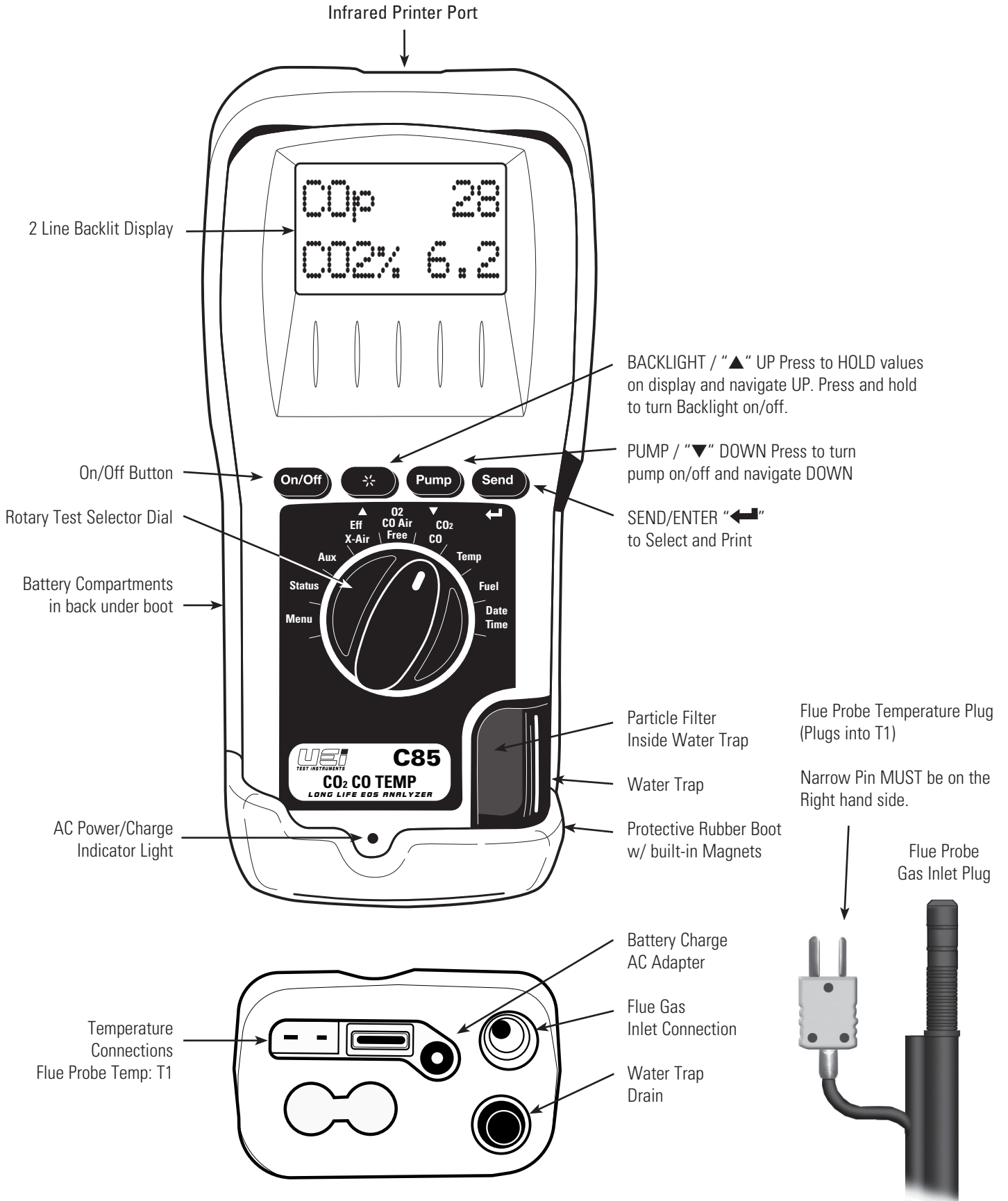

GETTING STARTED



SAFETY NOTES

Before using this meter, read all safety information carefully.

“WARNING” is used to indicate conditions or actions that may pose physical hazards to the user.

“CAUTION” is used to indicate conditions or actions that may damage this instrument.



WARNING!

This analyzer extracts combustion gases that may be toxic in relatively low concentrations. These gases are exhausted from the back of the instrument. This instrument must only be used in well-ventilated locations. It must only be used by trained and competent persons after due consideration of all the potential hazards.

MENU / SETUP

SET TIME

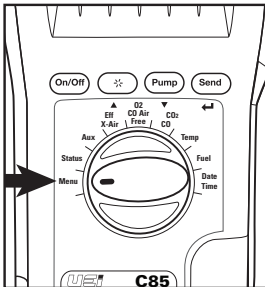

Rotate dial to **Menu**

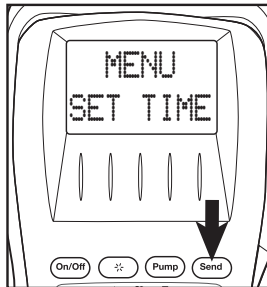

SET TIME shows press “Send”

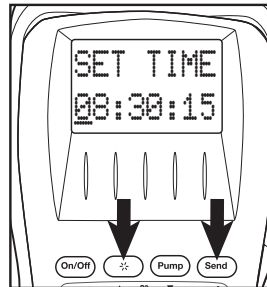

Clock displays with the cursor underneath the first digit. Press “▲” UP or “▼” DOWN to increase or decrease and press ENTER “←” to set and proceed to the next digit.

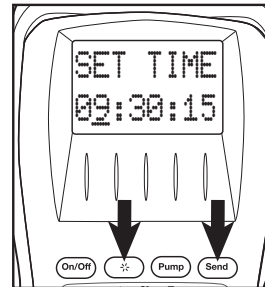

Press “▲” UP or “▼” DOWN to increase or decrease and press ENTER “←” to set and proceed to the next digit.

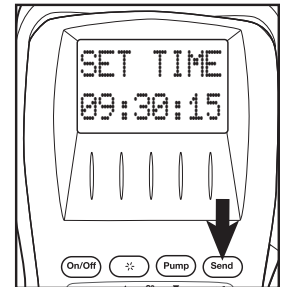

Press “Send” to complete setting the time once all digits are set.

SET DATE

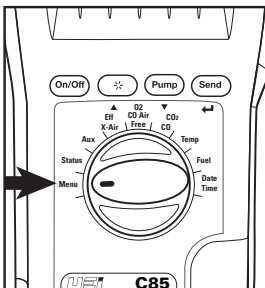

Rotate dial to **Menu**

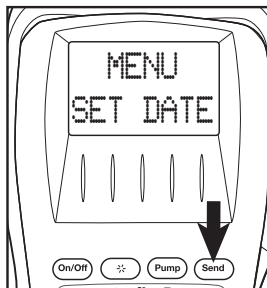

Press “▲” UP or “▼” DOWN to “SET DATE”
Press ENTER “←”

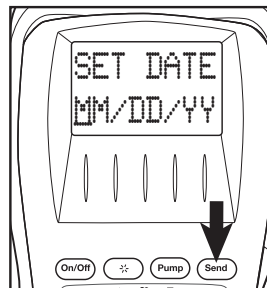

Set date displays with MM/DD/YY Press “▲” UP or “▼” DOWN to select a different format press ENTER “←” to proceed. Use MM/DD/YY for North American.

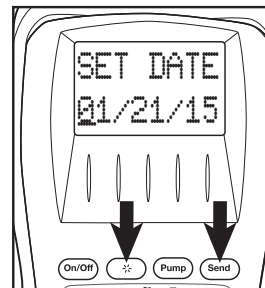

Date displays with the cursor underneath the first digit. Press “▲” UP or “▼” DOWN to increase or decrease and press ENTER “←” to set and proceed to next digit.

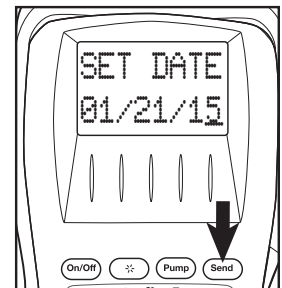

Press ENTER “←” to complete setting the date once all digits are set.

SET AUXILIARY SCREEN (Aux)

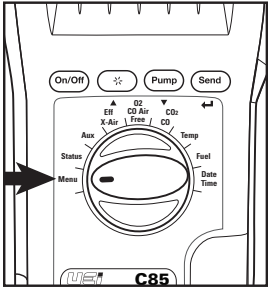

Rotate dial to **Menu**

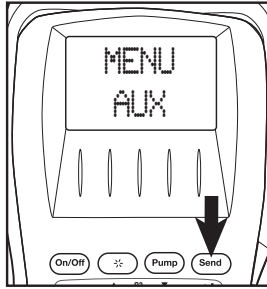

Press "▲" UP or "▼" DOWN to "AUX"
Press ENTER "↵" to set.

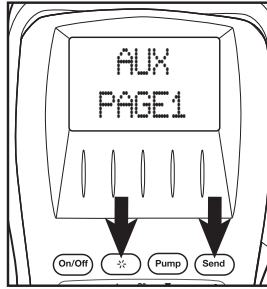

AUX PAGE 1 shows press ENTER "↵" to set.

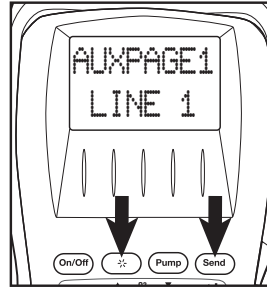

AUXPAGE1 LINE 1 shows press ENTER "↵" to continue to set line 1.

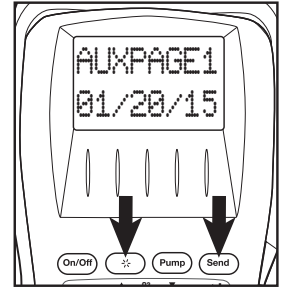

Press "▲" UP or "▼" DOWN select between available parameters and press ENTER "↵" to set.

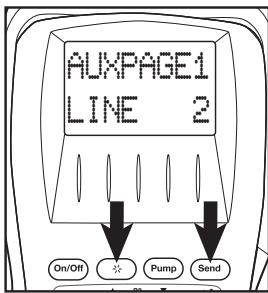

AUXPAGE1 LINE 2 shows press "Send" to continue to set line 2. Press "▲" UP or "▼" DOWN select between available parameters and press ENTER "↵" to set.

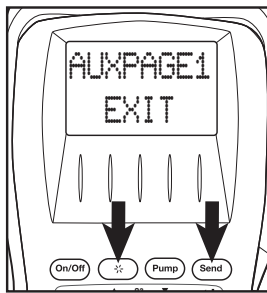

AUXPAGE1 EXIT shows press ENTER "↵" to proceed.

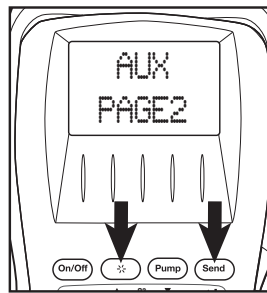

AUX PAGE2 shows press ENTER "↵" to proceed to set page 2. Repeat the same process as page 1 to set page 2.

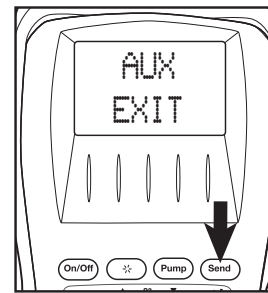

Press ENTER "↵" to exit.

ADJUST CONTRAST

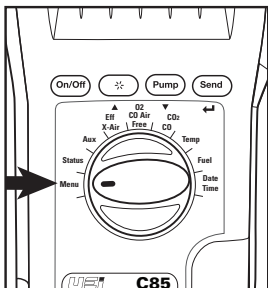

Rotate dial to **Menu**

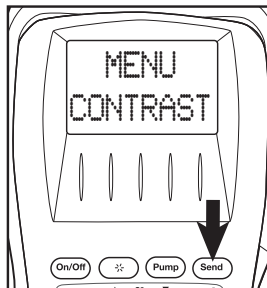

Press "▲" UP or "▼" DOWN to "CONTRAST"
Press ENTER "↵" to set.

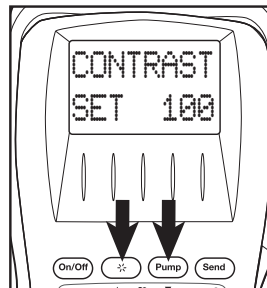

Press "▲" UP or "▼" DOWN to adjust screen contrast. NOTE: The higher the value the lighter the digits appear

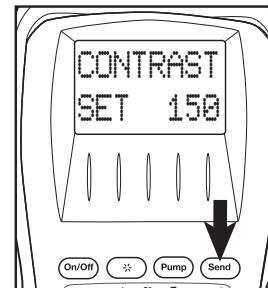

Press ENTER "↵" to exit.

CUSTOMIZABLE HEADER (ON PRINTOUTS)

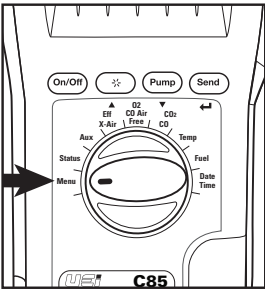

Rotate dial to **Menu**

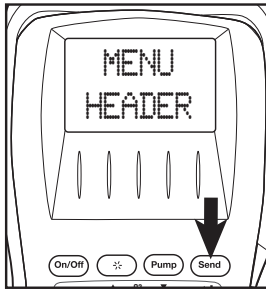

Press "▲" UP or "▼"
DOWN to "HEADER"
Press ENTER "↵" to proceed.

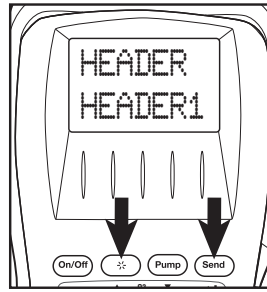

Press "▲" UP or "▼"
DOWN to select HEADER 1
Press ENTER "↵" to proceed.

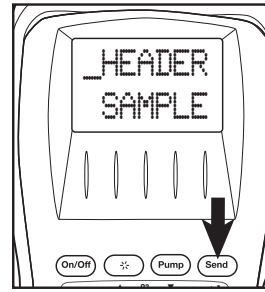

The existing HEADER 1 will display with the cursor underneath the first digit. Press "▲" UP or "▼" DOWN to change and press ENTER "↵" to set and continue to the next digit. Press ENTER "↵" to proceed.

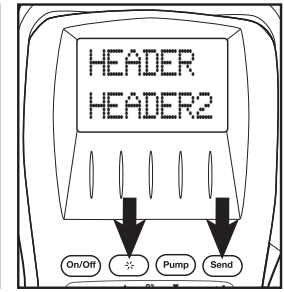

Repeat the process for HEADER 2 and press ENTER "↵" to proceed.

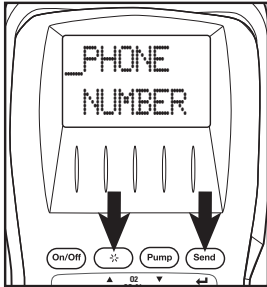

The existing HEADER 2 will display with the cursor underneath the first digit. Press "▲" UP or "▼" DOWN to change and press ENTER "↵" to set and continue to the next digit. Press ENTER "↵" to proceed.

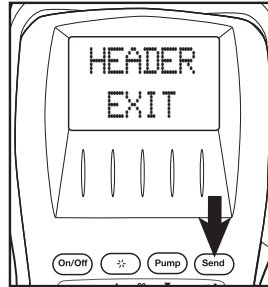

Press ENTER "↵" to exit.

SET LANGUAGE

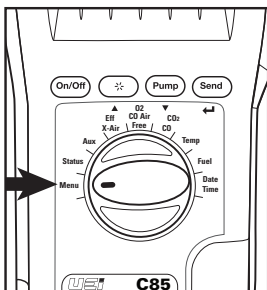

Rotate dial to **Menu**

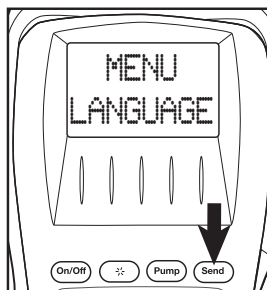

Press "▲" UP or "▼"
DOWN to "LANGUAGE"
Press ENTER "↵"

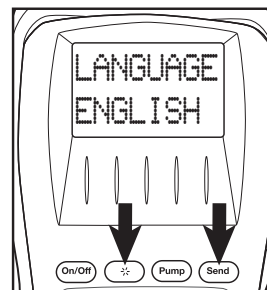

Press "▲" UP or "▼"
DOWN to change language and press ENTER "↵" to set and exit

VIEWING AND PRINTING REPORTS

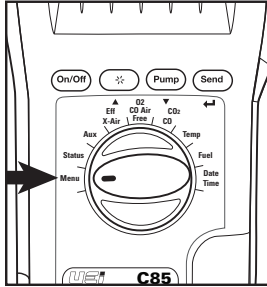

Rotate dial to **Menu**

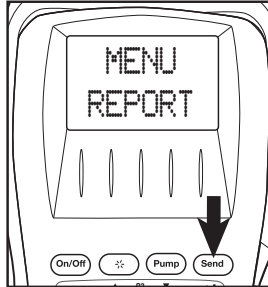

Press "▲" UP or "▼" DOWN to "REPORT"
Press ENTER "◀" "

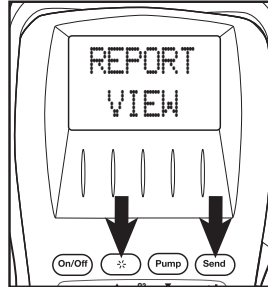

Press "▲" UP or "▼" DOWN to "VIEW" press ENTER "◀" to proceed.

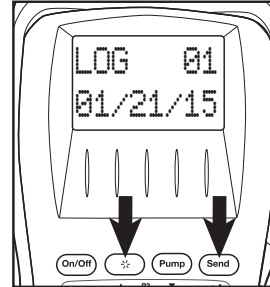

Press and hold "▲" UP or "▼" DOWN to select log to view (LOG 01, LOG 02). Press "▲" UP or "▼" DOWN to scroll and view parameters on second line.

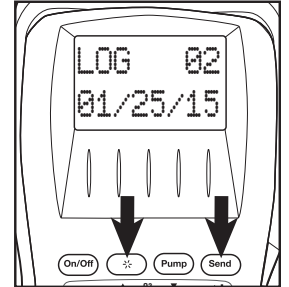

Press "Send" to print LOGGED results. press ENTER "◀" again to abort.

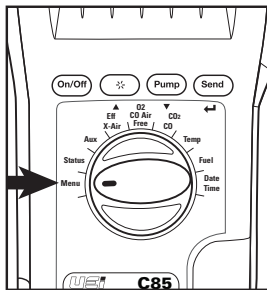

Rotate dial to **Menu**

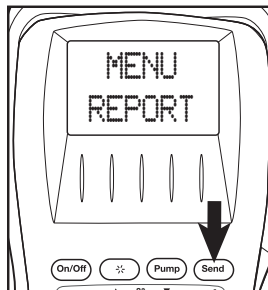

Press "▲" UP or "▼" DOWN to "REPORT"
Press ENTER "◀" "



Press "▲" UP or "▼" DOWN to "DEL ALL"
Press ENTER "◀" to proceed.



Press "▲" UP or "▼" DOWN to select Yes or No
Press ENTER "◀" to proceed. Analyzer will automatically return to the menu.

PRINT SETUP

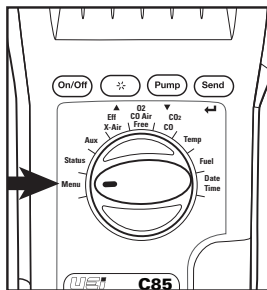

Rotate dial to **Menu**

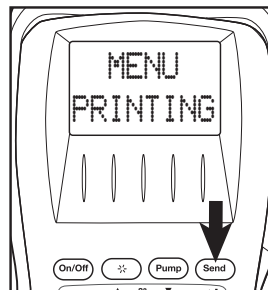

Press "▲" UP or "▼" DOWN to "PRINTING"
Press ENTER "◀" "

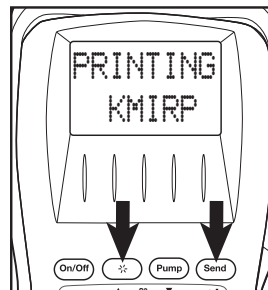

Press "▲" UP or "▼" DOWN to select printer.
Press ENTER "◀" to select. Analyzer will automatically return to the menu.

Printer Options

- **KMIRP2** for legacy infrared thermal printer
- **IRP-3** for easy-load fast printer

NOTE: If using the KMIRP2 printer and incomplete reports are printing check the print setup

BASIC FAST START (OPERATION)

1. POWER ON

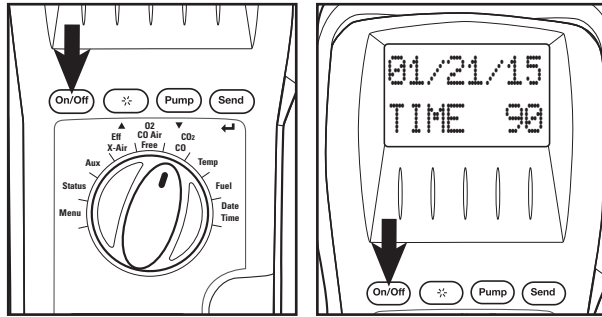

Power on in area of fresh air and allow to countdown. On sealed combustion appliances (ducted inlet) connect flue probe and power on outside and allow to countdown to set inlet temperature. (see page 12)

2. SELECT FUEL

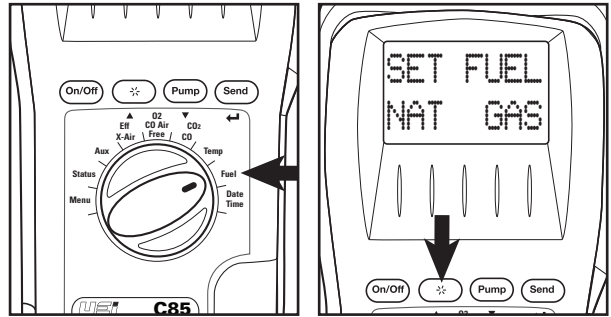

Rotate test selector to **Fuel**.

Press “▲” UP or “▼” DOWN to scroll and press “Send” to select desired fuel. Bottom line displays selected fuel.

3. CONNECT PROBE

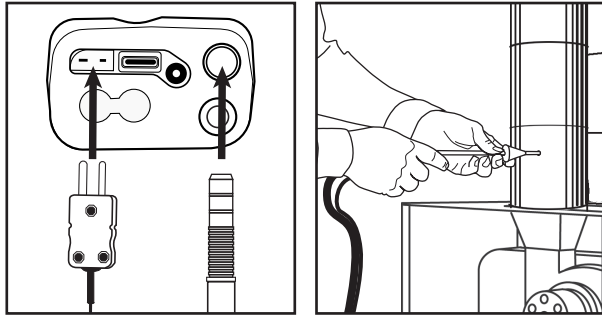

Connect flue probe thermocouple connector to T1, and connect flue probe to water trap as shown above.

Insert Flue Probe in stack. Adjust the cone so the end of the probe is approximately at the center of the stack (4" stack adjust cone to approx. 2" from end of probe.)

4. SELECT PARAMETER TO VIEW / LOG / PRINT

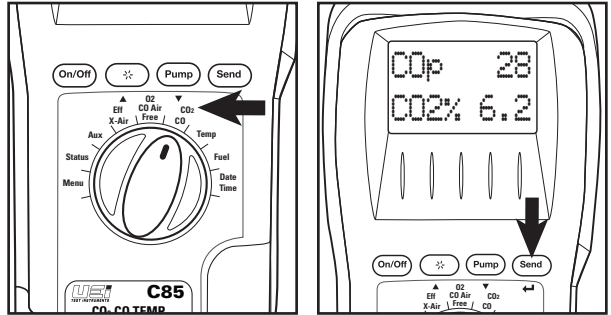

Rotate selector to desired test.

Press “Send” to print results or press and hold “Send” to log results from any screen.

Status

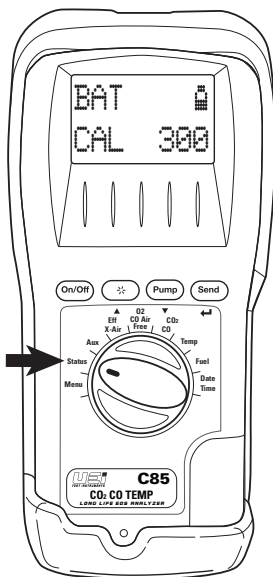

Rotate selector to **Status**.

The status menu shows battery life and the number of days until suggested re-certification. (CAL)

Aux

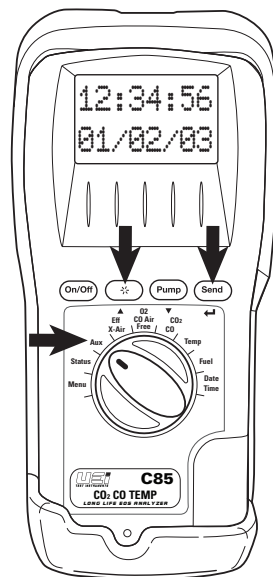

Rotate selector to **Aux**.

The auxiliary menu shows user defined parameters. The display alternates between page 1 and page 2.

To set up the auxiliary menu see instructions on page 5.

Eff / X-Air

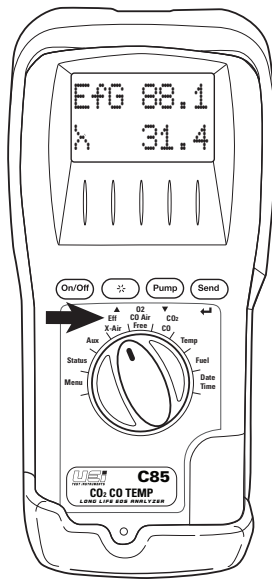

Rotate selector to **Eff X-Air**.
The Eff/X-Air screen shows calculated combustion efficiency using a Gross Condensing calculation and excess air. When below condensing temperature the efficiency calculation includes and estimated energy recovered during condensation that increases combustion efficiency. **This calculated value is not the same as AFUE.**

Excess air is a calculated value representing the amount of air above the level needed to completely burn all of the fuel.

NOTE: Negative net temperature will result in efficiency greater than 100%

O2 CO Air Free

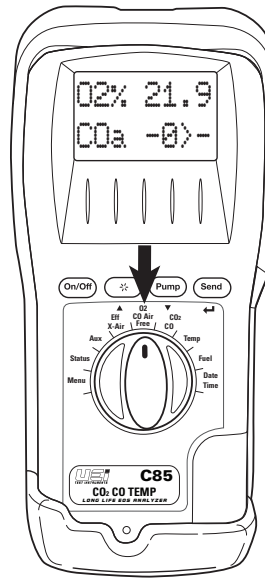

Rotate selector to **O2 CO Air Free**.

The O2/CO Air free screen shows the calculated amount of O2 (from CO2 measured and fuel selected), and CO Air Free.

CO Air free is a calculated value for carbon monoxide as if there were no dilution from air.

COppm = $[20.9 / (20.9 - O2 \text{ measured})]$

CO2 CO

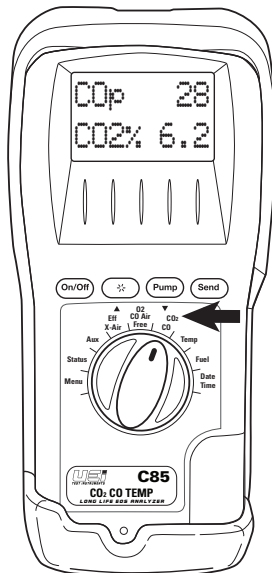

Rotate selector to **CO2 CO**.

The CO2 / CO screen is a direct display of measured gases. Carbon dioxide (CO2) is displayed in percentage (%), carbon monoxide (CO) is displayed in parts per million (ppm).

These two measurements are commonly referenced target values for appliance set up.

Temp

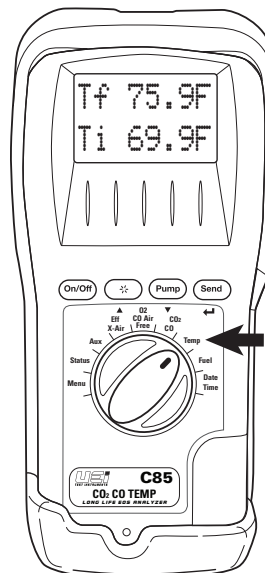

Rotate selector to **Temp**.

The temperature screen will display values for flue temperature (Tf) and inlet temperature (Ti). If inlet temperature was set during initial power on, it will display that temperature. If using ambient temperature you will observe the internal handset temperature.

Note: The sample pump will stop when CO is less than 40ppm.

Fuel

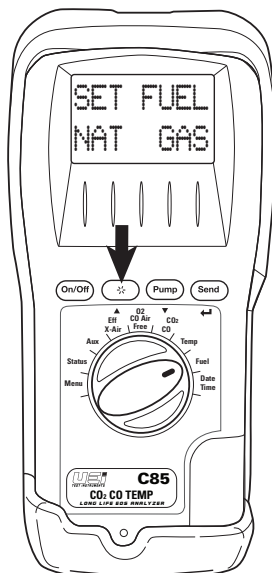

Rotate test selector to **Fuel**.
The fuel selector position will display the current fuel being used for calculations.

Press "▲" UP or "▼" DOWN to scroll and press ENTER "←" to select desired fuel. Bottom line displays selected fuel selected for calculations

Date Time

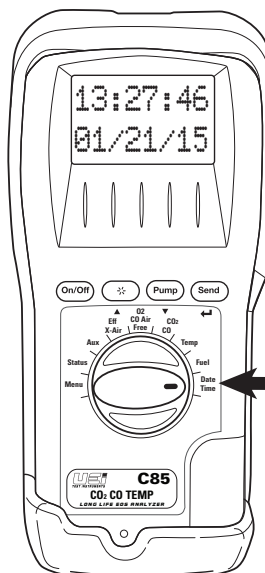

Rotate test selector to **Date Time**.

Display shows internal clock and the date.

WHERE TO TEST

Air Conditioning / Heat Pump

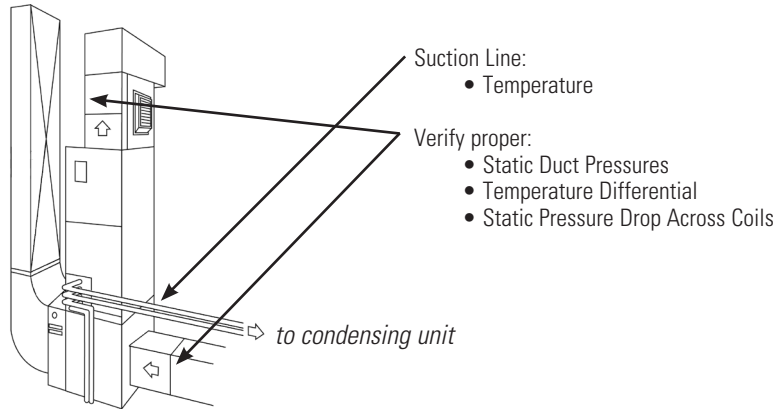

Boiler & Water Heaters & High Efficiency Modulating Hot Water Systems

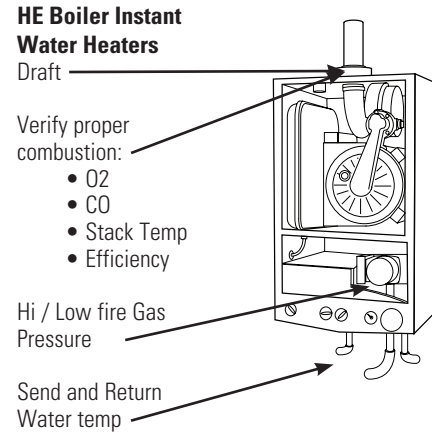
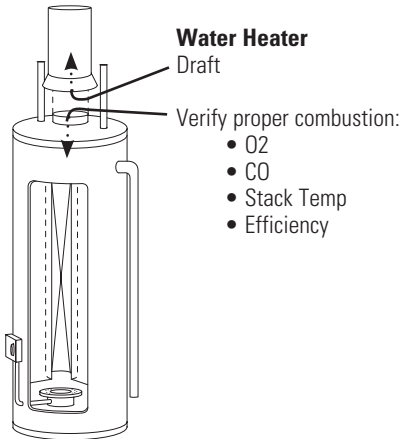
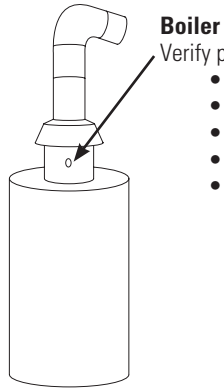

Furnaces: 80%

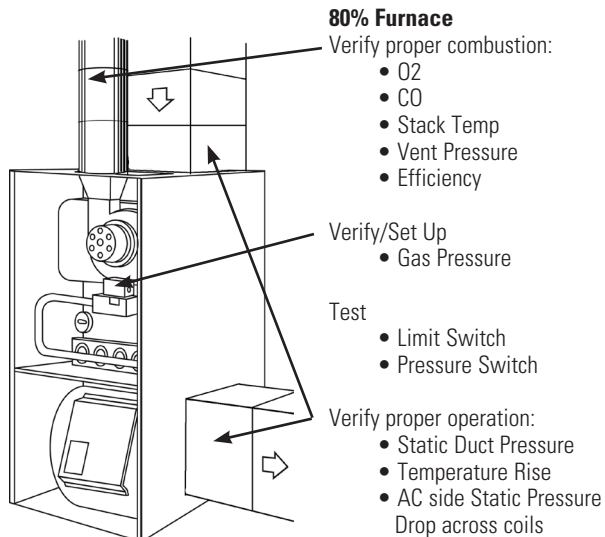

Furnaces: 90%

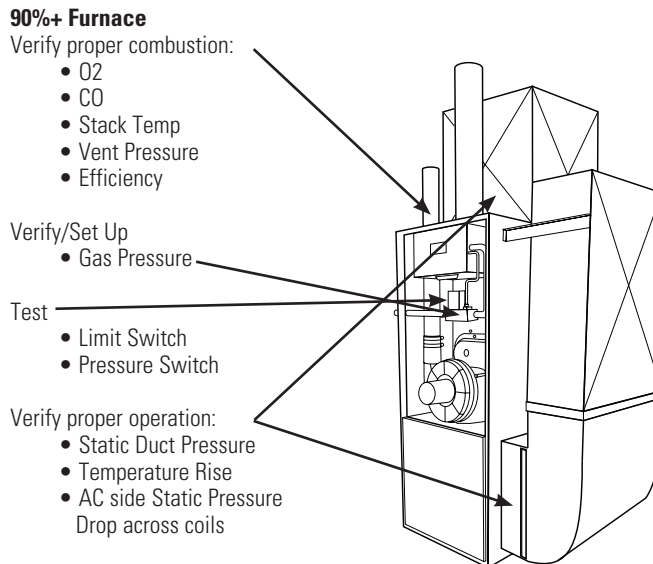

WHERE TO TEST (CONT.)

Furnaces (continued): Atmospheric, Gas & Oil

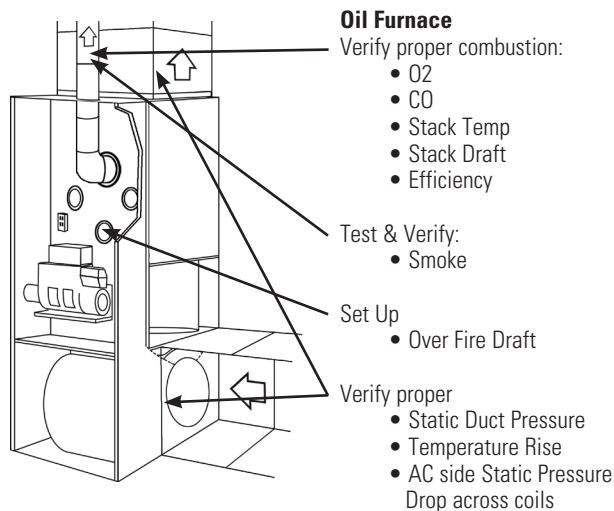
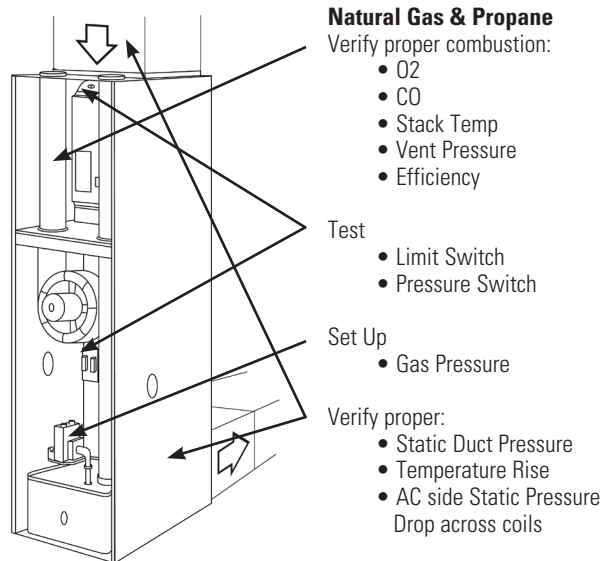
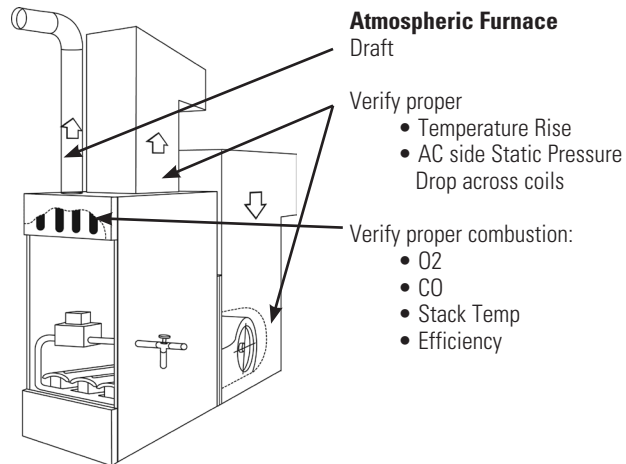

WHAT RESULTS ARE GENERALLY ACCEPTABLE

Atmospheric Gas Fired Burners

- Oxygen 7 to 9% O₂
- Stack Temperature 325 to 500°F
- Draft (Water Column Inches) -.02 to -.04wc"
- Carbon Monoxide (parts per million) <100ppm

Gas Fired Power Burners

- Oxygen 3 to 6% O₂
- Stack Temperature 275 to 500°F
- Stack Draft (Water Column Inches) -.02 to -.04wc"
- Overfire Draft (Water Column Inches) -.02wc"
- Carbon Monoxide (parts per million) <100ppm

Oil Fired Burners (#2 Oil Fuel)

- Oxygen 4 to 7% O₂
- Stack Temperature 325 to 600°F
- Stack Draft (Water Column Inches) -.04 to -.06wc"
- Overfire Draft (Water Column Inches) -.02wc"
- Carbon Monoxide (parts per million) <100ppm
- Smoke 0 (or manufacturer's recommendation)

Positive Overfire Gas & Oil

- Oxygen 3 to 9% O₂
- Stack Draft (Water Column Inches) -.02 to -.04wc"
- Overfire Draft (Water Column Inches) +0.4 to +0.6wc"
- Carbon Monoxide (parts per million) <100ppm

NOTE: Follow manufacture guidelines for the specific equipment being serviced.

Typical Excess Air Level

	O ₂ % (measured)	Excess Air %
Natural gas	3%	16.7%
Light Oil	5%	31%
Coal	8%	62%

GENERAL MAINTENANCE

- Re-certify your instrument annually to ensure it meets original performance specifications
- Keep your instrument dry. If it gets wet, wipe dry immediately. Liquids can degrade electronic circuits
- Whenever practical, keep the instrument away from dust and dirt that can cause premature wear
- Although your instrument is built to withstand the rigors of daily use, it can be damaged by severe impacts. Use reasonable caution when using and storing the meter

PRE TEST CHECKLIST

- Clean particle filter
- Water trap and probe line are empty of water
- Power on and zero
- All hose and thermocouple connections are properly secured
- Flue gas probe is sampling ambient FRESH air
- Water trap is fitted correctly to the instrument
- Flue temperature plug is connected

SETTING INLET TEMPERATURE

- Turn on and zero the analyzer with out the flue probe connected to use ambient temperature
- Connect flue probe thermocouple to T1 during zero countdown to store probe tip temperature as inlet (ducted system)

ANALYZER CONNECTIONS



WARNING!

Turning the pump off while the probe is in the flue will leave toxic gases inside the analyzer. Once data has been printed or copied it is advisable to purge the unit with fresh air as soon as possible. To do this remove the probe from the flue and turn ON the pump. Always allow the readings to return to zero (20.9 for O₂) prior to shutting the unit off. The meter will not switch off until the CO reading is below 20 ppm.



WARNING!

The probe will be hot from flue gases. Remove the probe from the flue and allow it to cool naturally. Do not immerse the probe in water, as this will be drawn into the analyzer and damage the pump and sensors. Once the probe is removed from the flue and the readings have returned to ambient levels hold down "On/Off" and switch off the analyzer. The instrument will count down from 30 to switch off. If you pressed "On/Off" by mistake, pressing "Send" will return you to normal operation.

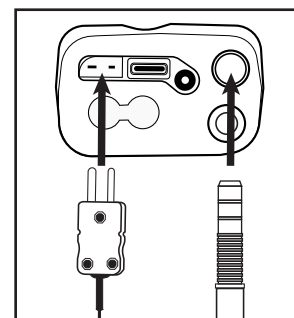

NOTE: Take care when inserting the temperature probes as the pins are polarized. Insert with the smaller pin (+) to the right.

NOTE: Do not insert anything into programming port.

EMPTYING & CLEANING THE IN-LINE WATER TRAP

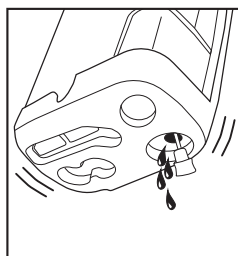

The in-line water trap should be checked and emptied on a regular basis. Water vapor will condense in the probe line, which may cause the water trap to fill suddenly if the probe is moved. Care should be taken at all times.

Carefully remove the rubber plug from the bottom of the water-trap housing. Dispose of the condensate in a suitable drain, care must be taken as it could be acidic. If condensate spills onto the skin or clothing, clean off immediately using fresh water, seek medical advice if problems occur. Ensure plug is replaced before performing combustion tests. Note: O₂ reading will be high if the Water Trap Plug is not in place.

CHANGING THE PARTICLE FILTER

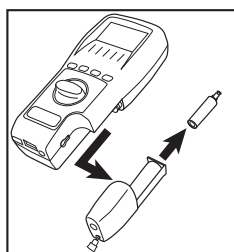

This is a very important part of the analyzer and should be changed regularly. It prevents dust and dirt particles from entering the pump and sensors that will cause damage. The filter **MUST** be changed when it appears discolored on the inner surface.

Remove water-trap assembly from the analyzer as shown above. Remove the filter and plastic holder from the housing. Discard the filter element but keep the holder to fit to the new filter. Clean the inside of the filter housing with a suitable soft cloth. Fit the holder onto the new filter element and then insert into the housing. Refit the housing onto the analyzer.

REPLACING THE BATTERIES

This meter has been designed for use with both alkaline and rechargeable Nickel Metal Hydride (NiMH) batteries. No other types are recommended. The analyzer is supplied with 4 "AA" size alkaline batteries. These should be installed into the instrument as shown in the diagram indicated on the back of the unit.



CAUTION!

Take great care when installing the batteries to observe correct polarity. Always check the meter for operation immediately after installing new batteries.

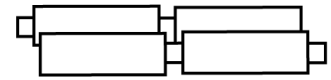

Using Re-Chargeable Batteries

The battery charger must only be used when NiMH batteries are fitted. Alkaline batteries are not re-chargeable. Attempting to recharge alkaline batteries may result in damage to the product and may create a fire risk.

Battery Charging

Ensure that you use the correct charger. This unit uses a 9V DC regulated charger. Ensure that the batteries are fitted in the correct manner, and then charge for at least 16 hours. Subsequent charges should be overnight. NiMH batteries may be charged at any time, even for short periods to conduct testing.



WARNING!

Under NO circumstance should you expose batteries to extreme heat or fire as they may explode and cause injury. Always dispose of old batteries promptly in a manner consistent with local disposal regulations.

POST TEST

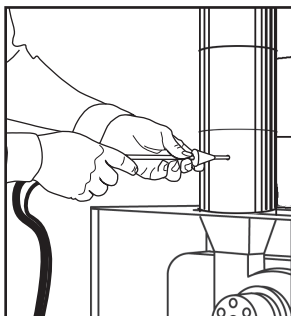

Remove the probe from the flue and allow the analyzer to purge with fresh air until readings return to zero. - O₂ to 20.9%, CO to Zero (Be careful as the probe tip will be HOT)

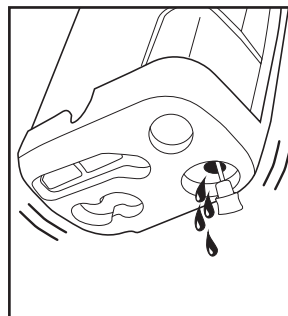
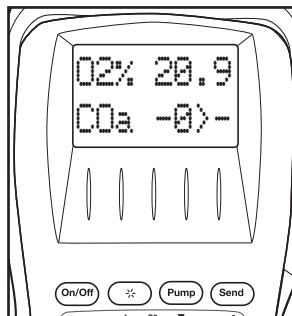

Drain water trap by unplugging the drain plug and shake to get excess water out.

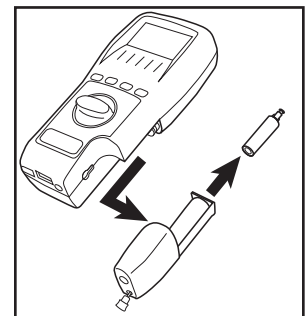

Check particle filter for dirt and any other sediment and replace if necessary.

PERIODIC SERVICE



WARNING!

Repair and service of this instrument is to be performed by qualified personnel only. Improper repair or service could result in physical degradation of the instrument. This could alter the protection from personal injury this meter provides to the operator. Perform only those maintenance tasks that you are qualified to do.

ANNUAL RE-CERTIFICATION

While the CO sensor has an expected life of more than five years in normal use it is recommended that the analyzer is re-certified at least annually. This is so that long-term drift on the sensor and electronics can be eliminated. Local regulations may require more frequent re-calibration and users should check with appropriate authorities to ensure they comply with relevant guidelines.

CLEANING

Periodically clean your instruments case using a damp cloth. DO NOT use abrasive, flammable liquids, cleaning solvents, or strong detergents as they may damage the finish, impair safety, or effect the reliability of the structural components.

OTHER IMPORTANT FACTORS RELATING TO COMBUSTION

The three T's of combustion

Time: Amount of time that the fuel and oxygen are together in the combustion chamber

Temperature: How high the temperature is determines the rate of oxidation, or speed of the combustion

Turbulence: How well the fuel and air are mixed

These three factors are all interrelated, and will move your results along the combustion curves.

COMBUSTION MEASUREMENT TERMS

Other parameters measured include net temperature, draft and efficiency.

Net Temperature

Net temperature is the difference between the combustion air entering the combustion chamber and the flue gas temperature past the heat exchange. This is used to determine how efficient the system is extracting heat from the combustion process in addition to the performance of the combustion process. On sealed systems that have ducted inlet air for combustion air, the net temperature must compare this air stream temperature with the flue gases. If the appliance simply uses room air for the combustion air, our analyzers have an internal temperature sensor in the handset, so it will use this temperature when calculating net temperature. The most accurate results for efficiency are obtained when measuring flue gases at the point where flue temperature (not flame temperature) is the highest.

Draft

Draft is the difference between the ambient pressure level and the pressure level in the flue.

This is created either by the natural buoyancy of the hot gases created in combustion lifting, or by an inducer fan that assists the flow of flue gases up the stack. Most combustion equipment will specify the amount of draft that is required for proper operation. Draft helps draw combustion air into the combustion chamber, and also helps in mixing the fuel and oxygen. Without proper draft, the combustion process can spill poisonous by-products into the space where the appliance is located. This can be a risk to those in the area, or create a danger to residents or employees working near the combustion equipment.

Efficiency

Efficiency is a measure of how well the fuel is burned to create heat, and how well the generated heat is captured for the intended use.

The information used to create this value are based on the fuels heating value, the heat lost up the flue and the gas components in the flue gas. The original method to determine efficiency included many manual methods and lookup charts. As an example you would measure the CO₂ level and the stack temperature and then reference a slide scale that would give you the relative efficiency number. UEI's electronic combustion analyzers perform the measurements on a continuous basis, and can calculate the efficiency as adjustments are being made. Combine this with a printout and you are able to provide a before and after comparison of the combustion equipment in relatively little time as part of normal servicing. **Combustion efficiency is not the same as AFUE (annual fuel usage efficiency). AFUE is not measurable with any portable flue gas analyzer.**

Combustion Efficiency Calculations

This identifies three sources of loss associated with fuel burning:

- Losses due to flue gases:
Dry Flue gas loss, Moisture and hydrogen,
Sensible heat of water vapor, Unburned gas
- Losses due to refuse:
Combustible in ash, riddling and dust
- Other losses:
Radiation, convection, conduction other unmeasured losses

Net efficiency calculations assume that the energy contained in the water vapor (formed as a product of combustion and from wet fuel) is recovered and the wet loss term is zero. Gross efficiency calculations assume that the energy contained in the water vapor is not recovered. Since the fuel air mixture is never consistent there is the possibility of unburned/partially unburned fuel passing through the flue. This is represented by the unburned carbon loss. Losses due to combustible matter in ashes, riddling, dust and grit, radiation, convection and conduction are not included.

CO Air Free

Certain standards (ANSI Z21.1) for Carbon Monoxide are stated in terms of air-free. Air-free refers to the concentration of CO in combustion gases undiluted with flue, or other gases containing little CO. This value is computed using an equation that takes into account the O₂ concentration of the flue gas.

- If 5% O₂ is measured (O_{2m}) in the flue then the CO gas value will be recalculated as if 0% were measured. The equation for air-free is as follows: $CO_{af} = CO \text{ PPM} \times [(20.9) / (20.9 - O_{2m})]$
- In our example if a reading of 325 PPM were measured then the air-free value would be calculated as follows:
 $CO_{af} = 325 \text{ PPM} \times [(20.9) / (20.9 - 5)]$ $CO_{af} = 325 \text{ PPM} \times [(20.9) / (15.9)]$ $CO_{af} = 427$

We may be given a limit on our gas range by the local authority, which stated that we must not emit more than 400-PPM Carbon Monoxide air-free. In the example we would be breaking the limit and corrective action should be taken to reduce the level of CO. Air-free values prevent false readings being submitted, e.g. allowing more air into the boiler will increase the oxygen level in the flue and dilute any toxic gas reading. Air-free referencing gives readings as if they were undiluted.

SPECIFICATIONS

Parameter	Range	Resolution	Accuracy
Temperature Measurements			
Flue Temperature	32 - 1112°F (0 - 600°C)	1.0° F/C	±5°F (2.0°C) ±0.3% reading
Inlet temperature	32 - 212°F (0 - 100°C)	1.0° F/C	±1° F/C ±0.3% reading
Temp (Nett) ²	32 - 1112°F (0 - 600°C)	1.0° F/C	±5°F (2°C) ±0.3% reading
Gas Measurements			
Carbon Monoxide (CO)	0 - 1999 ppm	1 ppm	±5ppm <100ppm ±5% rdg >100ppm
Carbon Dioxide (CO2)	0 - 30%	0.1%	±0.3%
Calculations			
Oxygen (O2)	0 - 21%	0.1%	±0.2%
Efficiency	0 - 99.9%	0.1%	±1.0%
Excess Air	0 - 250%	0.1%	±0.2%

GENERAL SPECIFICATIONS

- **Operating Altitude:** 2000m (6,561 ft.)
- **Storage Altitude:** 10,000m (32,808 ft.)
- **Operating Temperature:** 32°F to 104°F (0°C to 40°C) at 10 - 90% R.H
- **Pollution Degree:** 2
- **Dimensions:** Handset: 7.9" (200mm) x 3.5" (90mm) x 1.8" (45mm)
Probe: (L) 7.9" (300mm) x (D) 0.25" (6mm) with 7.8" (200mm)
6ft (3m) neoprene hose
- **Weight:** 2.2lbs (1kg)
- **Certifications:** EMC EN 50081-1, EN 50082-1, CE
- **Battery Type:** 4 x 1.5V AAA
- **Power Supply Input:** 110V AC Output: 9V DC Regulated

ELECTROMAGNETIC COMPATIBILITY (EMC)

This product has been tested for compliance with the following generic standards: EN 50081-1, EN 50082-1 and is certified to be compliant.

The European Council Directive 89/336/EEC requires that electronic equipment does not generate electromagnetic disturbances that exceed defined levels and has an adequate level of immunity to enable it to be operated as intended.

Since there are many electrical products in use that pre-date this Directive and may emit electromagnetic radiation in excess of the standards defined in the Directive there may be occasions where it would be appropriate to check the analyzer prior to use. The following procedure should be adopted.

- Go through the normal start up sequence in the location where the equipment is to be used
- Switch on all localized electrical equipment that might be capable of causing interference
- Check that all readings are as expected (a level of disturbance in the readings is acceptable)
- If not, adjust the position of the instrument to minimize interference or switch off, if possible, the offending equipment for the duration of the test

At the time of writing this manual (January 2015) UEI is not aware of any field based situation where such interference has ever occurred and this advice is only given to satisfy the requirements of the Directive.

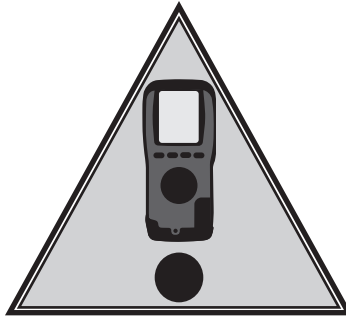

SERVICE

IMPORTANT: PRODUCT REGISTRATION

Register your product online at www.ueitest.com and click the PRODUCT REGISTRATION banner. This allows us to notify you when your analyzer has upgrades available or when recertification is due. We manufacture industry-leading products for professionals like you; please help us to ensure your product is always fit for purpose by registering your new purchase online - it only takes a few minutes.

IMPORTANT: RE-CERTIFICATION

While the CO sensor has an expected life of more than 5 years in normal use, it is recommended that the analyzer is recertified annually. The C85 analyzer typically requires an annual recertification each of the first four years and full recertification on the 5th year pending use. This eliminates long term drifting of the sensor and electronics. Local regulations may require more frequent calibration and users should check with appropriate authorities to ensure compliance.

UEi Test Instruments offers 2 kinds of recertification services.

Annual: Calibration of all installed sensors

Full: Replacement of all applicable sensors

Both services offer:

Full system, 30-point inspection with replacement of any failed parts.

Firmware and/or software upgrades as needed.

Certificate of calibration provided for record keeping.

Recertification work report to document work completed.

Units returned cleaned with paid return freight.

All units are recertified by trained professionals, which eliminate the legal liability of self-installed sensors. In the USA we have two recertification locations, one in Indianapolis, IN the second in Portland, OR. For Canadian customers we have a recertification service center in Vancouver, BC, which is ISO/IEC 17025:2005 accredited and offers NIST certification services for select products. All recertification services are warranted for one year.

Save time with online recertification check-in by visiting www.ueitest.com and click the SERVICE REQUEST banner and filling out the form. Our current recertification prices can be found on the SERVICE section of our web site. Up front pricing means NO surprises.

LIMITED WARRANTY

The C85 combustion analyzer is warranted for five years including sensors.

If within the warranty period your instrument should become inoperative from such defects, the unit will be repaired or replaced at UEi's option. This warranty covers normal use and does not cover damage which occurs in shipment or failure which results from alteration, tampering, accident, misuse, abuse, neglect or improper maintenance (calibration). Batteries and consequential damage resulting from failed batteries are not covered by warranty. Any implied warranties, including but not limited to implied warranties of merchantability and fitness for a particular purpose, are limited to the express warranty. UEi shall not be liable for loss of use of the instrument or other incidental or consequential damages, expenses, or economic loss, or for any claim or claims for such damage, expenses or economic loss. A purchase receipt or other proof of original purchase date will be required before warranty repairs will be rendered. Instruments out of warranty will be repaired (when repairable) for a service charge. Contact UEi for specific warranty and service information. This warranty gives you specific legal rights. You may also have other rights which vary from state to state.

USA

1-800-547-5740 • Fax: (503) 643-6322
www.ueitest.com • Email: info@ueitest.com

8030 SW Nimbus Ave.
Beaverton, OR 97008

CANADA

1-877-475-0648 • Fax: (604) 278-8299
www.ueitest.com • Email: infocanada@ueitest.com

150-13571 Verdun Place
Richmond, B.C.
V6V 1W5

EUROPE

+44 1707 375550 • Fax: +44 1707 393277
www.ueitest.com • Email: info@ueitest.com