



Instruction Sheet

302-364

Viridian™ 15-30 (-1 and -2 Models)

SUPERSEDES: March 1, 2013

EFFECTIVE: October 24, 2013

1. GENERAL INFORMATION, USES:

The circulating pumps are used for the transfer of liquid media within a closed-looped hot-water heating or air-conditioning hydronic system. They are designed as single or parallel main/standby operation variable-speed pumps, where the speed is regulated by an on-board electronic device. They are to be used with a water or glycol/water mixture.

2. SAFETY:

These instructions should be studied carefully before installing or operating the pump. They are meant to help you with installation, use and maintenance and to increase your safety. Installation should be performed with regards to local or national standards. Only qualified personnel should maintain and service these products. Failure to comply with safety precautions could cause personal injury or machinery damage.



WARNING: Do not use in swimming pool or spa areas. Pump has not been investigated for these applications.
AVERTISSEMENT: Ne pas utiliser dans une piscine ou un spa. La pompe n'a pas été étudiée pour ces applications.



WARNING: To avoid electrical shock, disconnect the power supply to the circulator and the main electrical unit. Follow all local electrical and plumbing codes.
AVERTISSEMENT: Pour éviter tout choc électrique, débranchez l'alimentation électrique vers le circulateur et l'unité électrique principale. Respectez tous les codes de plomberie et électriques locaux.



WARNING: Hot surfaces can cause burns. The motor can also reach temperatures that could cause injury.
AVERTISSEMENT: Les surfaces chaudes peuvent provoquer des brûlures. Le moteur peut également atteindre des températures qui peuvent entraîner des blessures.



CAUTION: The addition of petroleum based fluids or certain chemical additives to systems using TACO equipment voids the warranty.
ATTENTION: L'ajout de liquides à base de pétrole ou de certains additifs chimiques à des systèmes utilisant un équipement TACO annule la garantie.



CAUTION: Use supply wires suitable for 90°C.
ATTENTION: Employer des fils d'alimentation adéquats pour 90°C.



CAUTION: Misconnection or overload of electrical or signal connections could cause pump to shut-down or cause permanent damage.
ATTENTION: Toute erreur de raccordement ou surcharge des connexions électriques ou de signalisation peut entraîner un arrêt de la pompe ou des dommages permanents.



CAUTION: Do not operate pump without the electrical cover securely attached.
ATTENTION: Ne pas actionner la pompe si le couvercle électrique n'est pas correctement fixé.



CAUTION: Pump motor, electronics enclosure and condensate drain openings should not be thermally insulated as it could interfere with cooling and condensate drainage.
ATTENTION: Le moteur de pompe, l'enceinte électronique et les ouvertures de drainage de condensat doivent être thermiquement isolés car il peut y avoir interférence avec l'évacuation de condensat et de liquide de refroidissement.

3. PUMP DESCRIPTION:

The high efficiency, electronically commutated Viridian pumps consist of two main parts, the centrifugal pump and the electronic regulator. The hydraulic part is hermetically sealed from the motor assembly and has no mechanical seals. Viridian pumps are powered by an ECM permanent magnet motor which does not consume energy to magnetize the rotor, providing superior energy efficiency. The ECM motor is run by an on-board frequency converter with an integrated PFC (Power Factor Correction) filter. The converter estimates current flow and head from the motor load, information essential for differential pressure control.

4. PUMP INSTALLATION:

The Viridian pump is protected with a double box during shipping. It can be lifted from the box with internal handles or by lifting it by the heat sink.



CAUTION: Pump may be heavy. Provide yourself help if needed.
ATTENTION: La pompe est lourde. Veillez à demander de l'aide si nécessaire.

Pumps are designed to be installed using standard ANSI class 125 flanges. It is recommended that the Viridian pumps be installed with at least 5 to 10 pipe diameters of straight pipe on the inlet and outlet of the pump. Use all nuts and bolts to attach companion flanges to the pump flanges. For pumps to operate with minimal vibration and noise, it should be installed with the axis in a horizontal position (see Figure 1).

Desired head orientation can be achieved by rotating the pump head. The pump is mounted to the volute with four screws. By unscrewing those the head can be turned. **Caution: When reassembling, care should be taken to avoid damaging the O-ring and insuring a tight seal.** For replacement O-rings, use part number 975-001RP. See detailed Motor Rotation Procedure 4.1 below.

Watch the Viridian Training Video at:

<http://www.taco-hvac.com/training/viridian/learn.html>



A Taco resource – saving product

Figure 1:

RECOMMENDED INSTALLATION POSITIONS

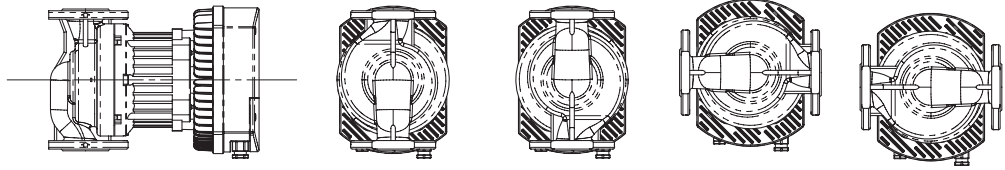

UNAUTHORIZED INSTALLATION POSITIONS

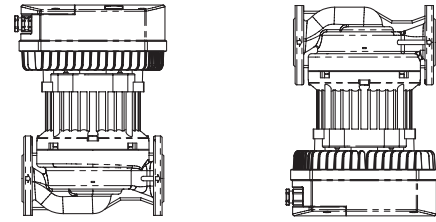

FLANGE BOLT SIZES	PUMP		CLASS 150 ANSI FLANGE			
Model/Flange Size	Bolt Hole Diameter	Flange Thickness	Bolt Hole Diameter	Flange Thickness	Minimum Bolt Size	Quantity
VR15 (1½")	0.63	0.715	0.62	0.688	½" x 2⅛"	4
VR 20 (2")	0.75	0.76	0.75	0.75	⅝" x 2⅜"	4
VR25 (2½")	0.75	0.76	0.75	0.875	⅝" x 2⅝"	4
VR30 (3")	0.75	0.84	0.75	0.938	⅝" x 2½"	4

4.1 Motor Rotation Procedure

Caution: Motor is heavy!

1. If possible, change the orientation of the motor before installing pump in piping. With motor in a vertical position, remove the 4 bolts (⅝" or 8mm hex wrench required) and turn the motor to agree with desired orientation of pump (see Figure 1). If motor won't turn, insert a screwdriver between pump casing and motor flange and raise slightly. Try turning motor. Insert screwdriver on opposite side, raise slightly, and try turning the motor. Motor should now turn - now line up bolt holes when desired orientation is achieved.
2. **Caution:** If system is filled and pressurized, shut off valve before and after the Viridian. Allow to cool if system fluid is hot.
3. If the pump is already installed in the piping, remove the 4 bolts (⅝" or 8mm hex wrench required) and try rotating the motor without backing it out from the pump casing. Try cracking the motor approximately .020" using a screwdriver between the motor and pump housing and try turning the motor.
4. If motor will not move, remove motor completely.
5. Remove impeller, rotor, and rotor can from the motor. Note: Rotor and impeller assembly will come out first. Remove rotor can from motor and put aside.
6. Install impeller and rotor assembly into pump.
7. While holding rotor, install O-ring in casing, and then slide rotor can over rotor and slide all the way in.
8. Rotor and rotor can should stay in place while you pick up the motor. If they do not, start over to assure O-ring is properly located and have someone hold the assembly in place with a screwdriver on top of the plate.
9. Pick up the motor with the terminals properly orientated and carefully start to slide the motor over the rotor can. The resistance of the sliding will keep the rotor and rotor can assembly in place and the screwdriver can be moved. **Note: Do not allow the motor to droop or the O-ring might get out of position.**
10. Line up the bolt holes, reinstall the bolts, and tighten in a cross-pattern.
11. Carefully open shut off valves and check for leaks.

Make sure that the electrical box cover is mounted and that all cable glands are installed to prevent dust and particles from contaminating the electrical box.

4.2 Electrical Connections:

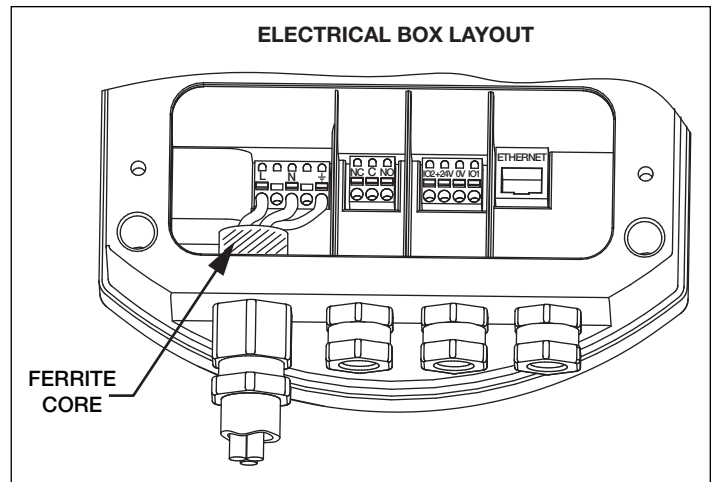

NOTE: For 200 to 240/1/60 volt, L1 and L2 are connected to L and N in the electrical box.

CONNECTION FUNCTIONS	
TERMINAL MARKINGS	DESCRIPTION
L	Electrical power supply. See pump ratings for applicable supply ranges.
N	
⊥	Ground connection
FERRITE CORE	Ferrite core for HF interference compliance. Ground, L and N wires should pass through it. (Part packaged separately.)
NC	Normally closed relay connection
C	Common relay connection
NO	Normally open relay connection
IO2	Digital input 2
24V	+24 Vdc @ 100mA max output
GND (0V)	24 Vdc ground
IO1	Digital input 1
ETHERNET	Ethernet connection

The pump has built-in over current fuse protection, temperature protection and basic overvoltage protection. It does not require additional overload protection devices unless required by local electrical codes. Power supply cabling should be capable of carrying rated power and be properly fused. Ground lead connection is essential for safety and should be connected first. Grounding is only meant for pump safety. System piping should be grounded separately. A ferrite core is supplied in a separate bag. Electronic cabling and wires, by virtue of their length-to-width ratios, are perfect natural antennas. The ground, line and neutral power supply wires should go through the ferrite core to help reduce unwanted high-frequency interfering signals. The pump should not be operated without the electrical cover securely attached.

4.3 Relay Connections:

The pump is supplied with normally open, normally closed and common relay connections. See Section 9.2 **Electrical Data** for specifications. These can be used to activate or deactivate a primary or secondary pump or alarm contact, actuate a damper for combustion air or switch another piece of equipment. Factory default is activation of relay on fault. Additional relay “triggers” are standby, I2 activation and run digital input commands.

4.4 Digital Inputs:

The pump can be switched between standby mode or maximum power via the digital inputs.

FACTORY DEFAULT FUNCTION	
I1 (IO1/0V)	Normally open or 2Vdc and less, pump runs normally. Closing contact (or applying 8Vdc or above) sets the pump to standby mode by disabling power to the motor (eg: for Warm Weather Shut Down). Additional I1 input signals are maximum power (speed) and no effect.
I2 (IO2/24V)	Closing I2 or 8Vdc and above (only when I1 is closed) forces the pump to run at Max (eg: purge system of air on start-up). Has no effect if I1 is open. Additional I2 input signals are run and no function.

4.4.1 Pump External Control Wiring Diagrams:

The following diagrams are examples of external control wiring to digital inputs I1 and I2.

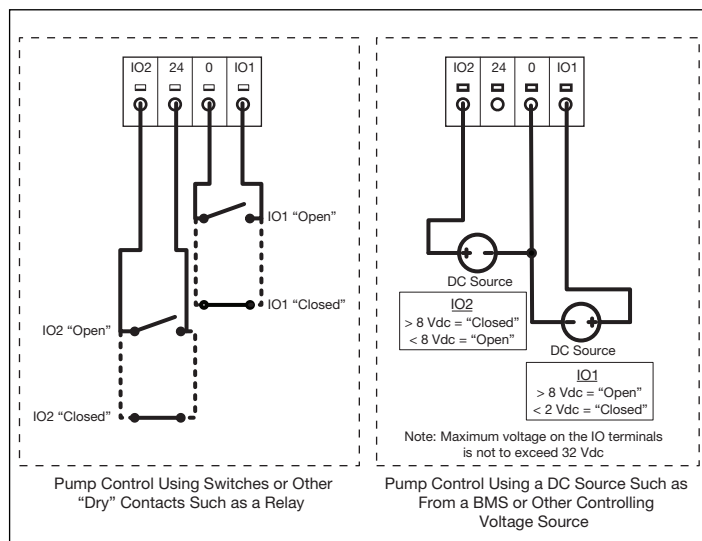

4.4.2 External Control Settings:

On/Off/Standby/Max speed external control variances and subsequent effects are listed in the chart below. Refer to Section 6.5 **Pump Settings** to modify digital input and relay settings from factory defaults.

4.5 Constant 24 Volt DC Power Supply:

There is a constant, unswitched 24Vdc/100mA output power supply across terminals 24V/0V. This power is interrupted only if the main power supply to the Viridian is turned off.

5. REGULATION MODES:

Pump defaults to provide 23 feet (7m) of head with variable differential pressure ($\Delta p-v$) regulation. If the factory settings are not suitable they can be modified over an Ethernet connector or a web interface. Various regulation parameters (constant head, supply power, rpm limit) can adjust the head and flow characteristics until the pump achieves desired response to suit the application.

5.1 Constant Pressure Control ($\Delta p-c$):

Electronic regulation can provide constant head by modifying power input and is set with the **Limit head (H_{max})** setting. The duty point of the pump will move left and right along a constant-pressure curve based upon the water demand in the system. The pump head (pressure) is kept constant, irrespective of the water demand. **H_{max} proportional to Q** needs to be set to 0% (see Section 6 **Connection to a Network - Pump Setup**).

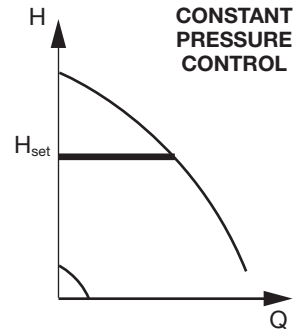

Selecting the constant pressure regulation is beneficial when the Viridian is installed in a system where there is a much lower resistance (friction loss) in the main distribution loop compared to the resistance in the transfer part of the system (i.e. baseboard radiation, radiant floors, terminal units). For example, this characteristic of generally lower head loss can be found in converted gravity systems, systems operating with large temperature spreads or where the pump is moving the total volume of flow through the boiler and distribution lines.

5.2 Variable Differential Pressure Control ($\Delta p-v$) - Factory Default Setting:

Additional energy savings and noise reduction is achieved with proportional head regulation that also compensates for changes in system friction losses during periods of changing flow rates. In this mode the pump head changes continuously as the demand for water changes, reducing as the water demand declines and increasing as the water demand rises.

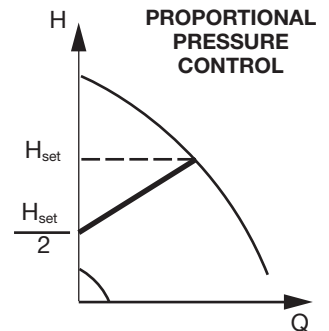

The **H_{max} proportional to Q** setting provides a user adjustable curve slope. An **H_{max} proportional to Q** of 0% means that the head does not exhibit any dependence to flow and should not exhibit noticeable change until maximum power is reached. An **H_{max} proportional to Q** set to 60% means that the pressure will drop for 60% from set value when there is no flow. For example if the head is set to 20', the pump will only provide 12' when the valves are closed and the pump is dead headed (operating at zero flow). The factory default is 23' at 50%. Note, a substantial percentage of glycol in the mixture can influence regulation.

Select the variable differential pressure control when the Viridian is installed in a system where there is a much higher resistance (friction loss) in the main distribution loop compared to the resistance in the transfer part of the system (i.e. baseboard radiation, radiant floors, terminal units). For example, this characteristic of the primary circuit having a high pressure drop can be seen in systems using modulating condensing boilers or heat exchanges, heavily throttled branch shut-off valves, where the distribution lines are long or in two pipe systems with thermostatic or zone valves.

VIRIDIAN STATES

INPUT SETTING		INPUT CONNECTIONS		PUMP STATE	RELAY SETTING (Default = Error)	RELAY STATUS (Normally Open)
IO1	IO2	IO1 Closed: <2 Vdc	IO2 Closed: >8 Vdc			
NF (0)	NF (0)	OPEN	OPEN	RUN	RUN	CLOSED
		OPEN	CLOSED	RUN	RUN	CLOSED
		CLOSED	OPEN	RUN	RUN	CLOSED
		CLOSED	CLOSED	RUN	RUN	CLOSED
RUN	NF (0)	OPEN	OPEN	RUN	RUN	CLOSED
		OPEN	CLOSED	RUN	RUN	CLOSED
		CLOSED	OPEN	OFF	RUN	OPEN
		CLOSED	CLOSED	OFF	RUN	OPEN
NF (0)	RUN	OPEN	OPEN	OFF	RUN	OPEN
		OPEN	CLOSED	RUN	RUN	CLOSED
		CLOSED	OPEN	OFF	RUN	OPEN
		CLOSED	CLOSED	RUN	RUN	CLOSED
RUN	RUN	OPEN	OPEN	OFF	RUN	OPEN
		OPEN	CLOSED	RUN	RUN	CLOSED
		CLOSED	OPEN	OFF	RUN	CLOSED
		CLOSED	CLOSED	OFF	RUN	OPEN
MAX	NF (0)	OPEN	OPEN	MAX	RUN	CLOSED
		OPEN	CLOSED	MAX	RUN	CLOSED
		CLOSED	OPEN	RUN	RUN	CLOSED
		CLOSED	CLOSED	RUN	RUN	CLOSED
NF (0)	MAX	OPEN	OPEN	RUN	RUN	CLOSED
		OPEN	CLOSED	MAX	RUN	CLOSED
		CLOSED	OPEN	RUN	RUN	CLOSED
		CLOSED	CLOSED	MAX	RUN	CLOSED
RUN (Default)	MAX (Default)	OPEN	OPEN	RUN	RUN	CLOSED
		OPEN	CLOSED	MAX	RUN	CLOSED
		CLOSED	OPEN	OFF	RUN	OPEN
		CLOSED	CLOSED	OFF	RUN	OPEN
MAX	RUN	OPEN	OPEN	OFF	RUN	OPEN
		OPEN	CLOSED	MAX	RUN	CLOSED
		CLOSED	CLOSED	RUN	RUN	CLOSED
		CLOSED	OPEN	OFF	RUN	OPEN
MAX	MAX	OPEN	OPEN	MAX	RUN	CLOSED
		OPEN	CLOSED	MAX	RUN	CLOSED
		CLOSED	OPEN	RUN	RUN	CLOSED
		CLOSED	CLOSED	MAX	RUN	CLOSED

LEGEND: **NF** = "No Function" Setting **BOLD** = Pump Running **BOLD ITALIC** = Maximum Speed

NOTE : **IO1** – "CLOSED" means connected to 0 - 2 Vdc
IO2 – "CLOSED" means connected to 8 - 24 Vdc

5.3 Constant Duty Curve (Unregulated Pump) Control:

An unregulated pump decreases its head with increasing flow. This unregulated setting can be achieved by setting the *limit head (Hmax)* to "no limit (99)" in the *pump* tab (see below) with a jumper across IO2/24V (or 8Vdc and above). Note: I1 must be closed and set to "no function". *Limit rpm* to should be set to the maximum value to achieve full pump curve. This allows the pump to run just like a conventional non-variable speed pump.

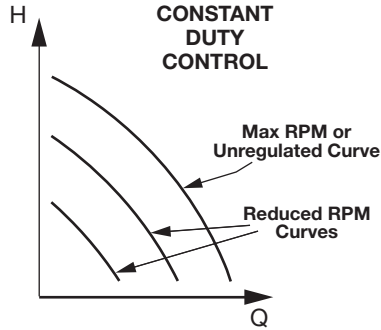

5.4 RPM Regulation:

Provides regulation similar to a manually adjustable pump.

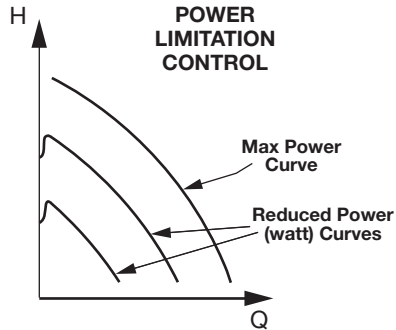

5.5 Power Limitation:

Artificially limits power consumption and output by selecting a maximum amp draw.

6. CONNECTION TO A NETWORK - PUMP SETUP:

In order to change the factory default operating parameters of the pump or to use various web tools the pump needs to be connected to a network or a personal computer over the Ethernet plug. Use CAT-4 or better network cable connected to "PATCH" configuration if plugged into a network or connect an Ethernet cable directly between a PC and the Viridian.

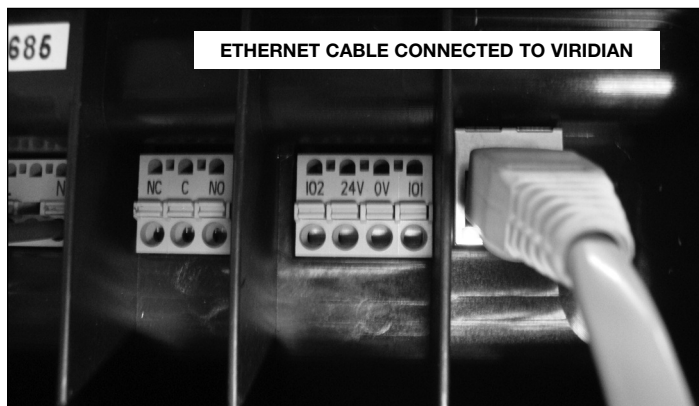
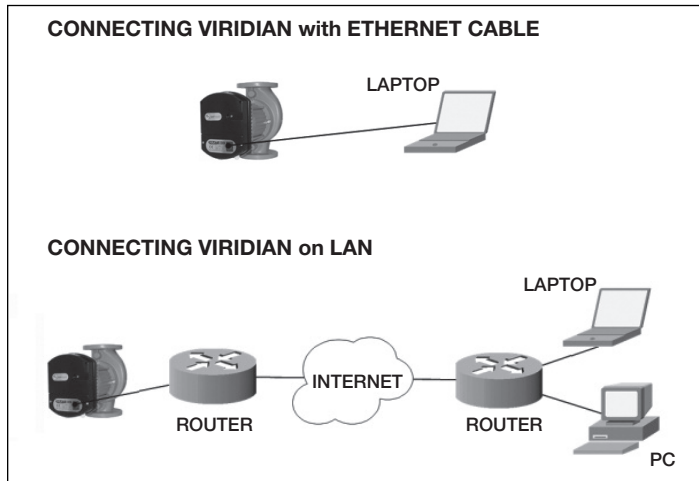

To achieve pump IP protection, network cable should be fed through the glanded inlet and then crimped to a connector. Ethernet plug is galvanically insulated, but the rest of the cabling could still present shock hazard.



CAUTION: All connections should be made with the power to the pump turned off.
ATTENTION: Tous les raccordements doivent être effectués avec l'alimentation électrique vers la pompe coupée.

If more than one pump will be connected into network, each individual pump should have its IP address and NetBIOS name changed and noted. That will prevent network confusion and provide naming service in relation to pump function.

6.1 Web Interface Settings:

When the Viridian is connected to a network or another computer, it can be reached by typing its IP address or NetBIOS name into the internet explorer's address line. The default IP address is 192.168.0.245 and default NetBIOS name is "viridian". The pump can be switched between standby mode or maximum power via the digital inputs.

6.2 Setting Up the Default IP Address:

Once the Ethernet cable is connected between the Viridian pump and either the laptop or network, go to your Control Panel and select Network Connections. Right click on Local Area Connection and choose properties. Highlight Internet Protocol Version 4 (TCP/IPv4) then click on properties. In the TCP/IP address use the following IP address "192.168.0.XXX" (example 192.168.0.123). Click OK to finish.

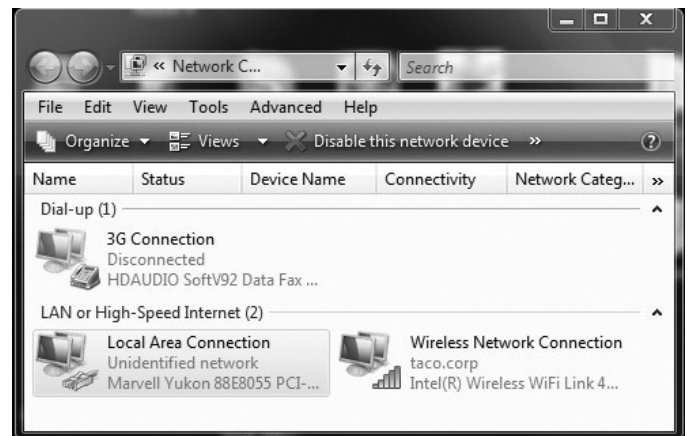

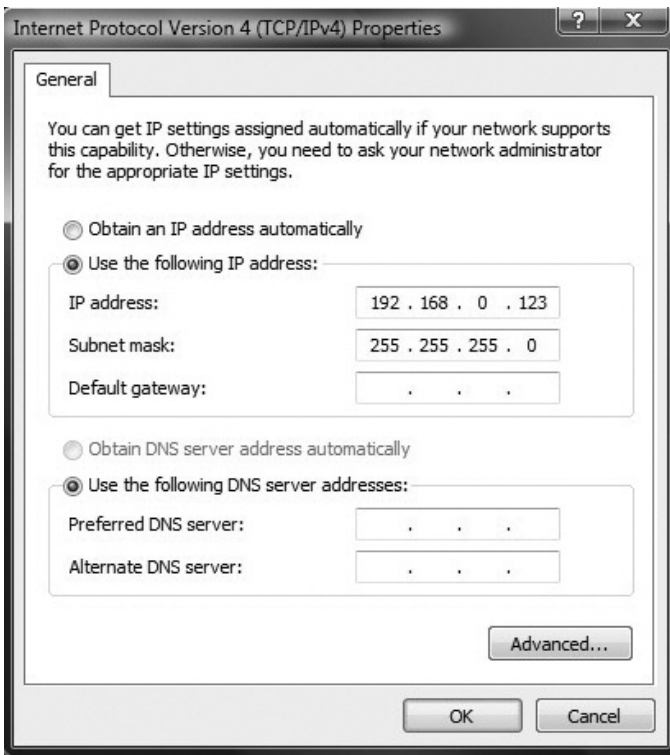
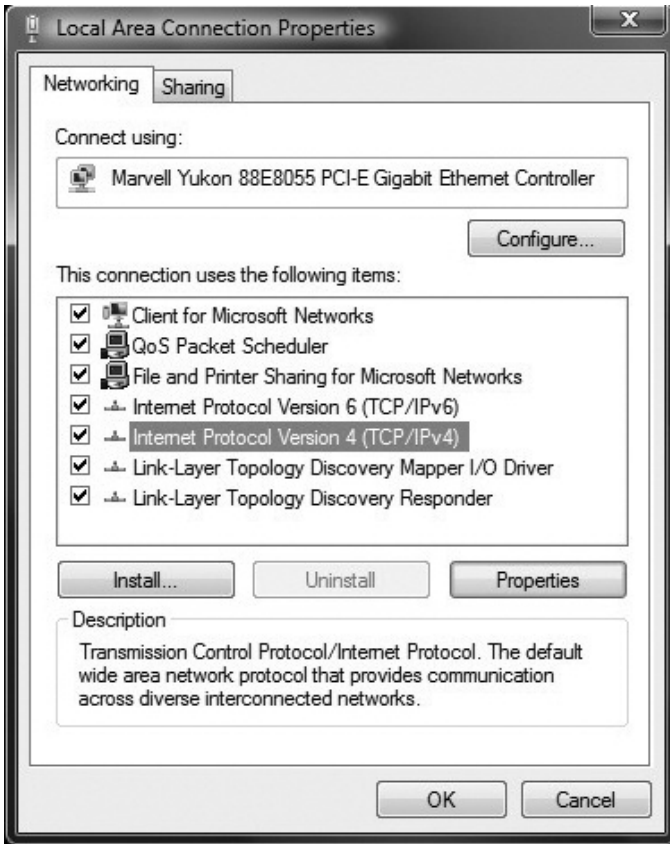

6.3 Connecting to the Pump:

Go to Internet Explorer, in the address line type <http://viridian> or the IP address of the pump.



6.4 Overview Page:

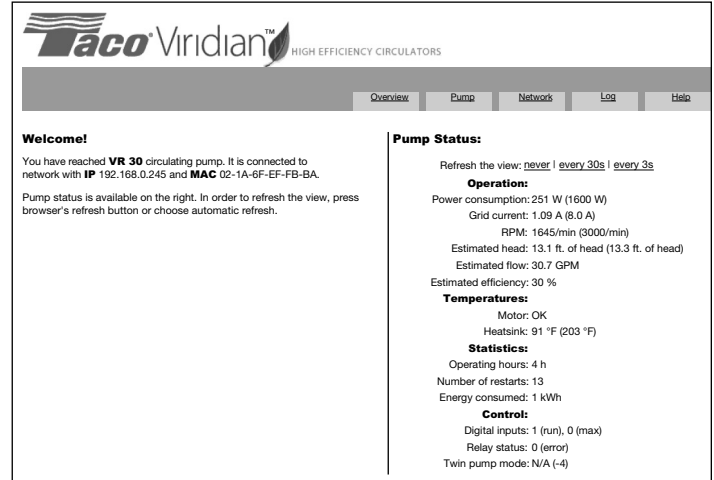

The overview page allows you to view the current status of the pump. You may select the intervals (never, every 30 seconds, every 3 seconds) of which you would like the data refreshed. It displays pump operation summary information, including:

- Power Consumption
- Amperage
- RPM
- Estimated Head
- Estimated Flow
- Estimated Efficiency
- Motor Status
- Heatsink Temperature
- Operating Hours
- Number of Restarts
- Accumulated Power Consumption
- Digital Inputs
- Relay Status

6.5 Pump Settings:

For more detail or to change any of the pump settings click on the Pump tab.

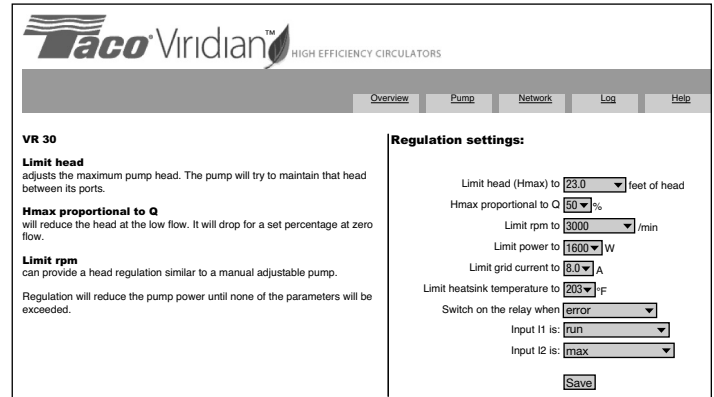

Limit head (Hmax) will set the maximum allowable head.

Hmax proportional to Q will set the ratio between head and flow:

Hmax = 0%: Constant pressure is set and should not exhibit noticeable change until maximum power is reached.

Hmax = X%: Parameter will set the percentage of drop in head from maximum to closed valve.

Limit rpm will limit motor speed.

Limit power to will set maximum wattage (max power consumption of the pump).

Limit grid current to will assign a maximum amp draw.

Limit heatsink temperature to will set a maximum temperature at the heatsink (electronics area).

Switch on the relay when can be set up as:

- Standby (operation)
- Active (run)
- Error detected (error)
- Active I2 (i2)

Input I1 is either:

- Run
- Run the pump (run)
- Full power (max)
- No function (0)

Input I2 has the functions the same as **I1**.

SAVE will write settings in permanent non-volatile memory.

6.6 Network Settings:

This page provides a way to change network configurations. Buttons operate in a similar manner as on previous pages.

6.7 Log:

This page will display possible errors.

6.7.1 Errors:

By clicking on either *current error* or *last error* you are brought to a page detailing the errors, the probable cause and possible solution. Also, errors can be viewed without having to connect to the pump through an Ethernet cable or the internet. A control light on the front panel provides fast overview of pump operation. The blue color signifies correct operation while the sequence of a blinking red indicates an error.

ERROR CODE	DESCRIPTION	PROBABLE CAUSE AND SOLUTION
(*)1	Low load detected	The pump might be running dry. Make sure the system is filled with fluid to prevent bearing damage.
(**)2	Overload trip, protective shutdown	Overcurrent, line surge or locked rotor caused the pump to restart. If the issue persists, check if the rotor is spinning freely
(***)3	Motor too hot	Motor has exceeded allowed temperature and is now stopped to cool down. Extremely hot medium or hardware failure might have caused that.
(****)4	Frequency converter error	Converter has detected an internal fault. The pump might still be operating, but needs repair.
(****)5	5 Motor/stator faulty	Motor does not behave as expected. Internal winding or wiring error might have caused that.

6.8 Help:

This page will redirect you to www.taco-hvac.com. Possible software upgrades and manuals will be available.

7. DIAGNOSTIC AND OPERATING LIGHTS:

A control light on the front panel provides fast overview of pump operation. The blue color signifies correct operation while red indicates an error.

BLUE LIGHT	
Blinking	Pump is in standby mode and not pumping water.
Solid On	Pump is operating as set

7.1 Red Light:

A red light blinks to indicate an error code. The sequence of the blinks is interrupted by a pause. The number of blinks between pauses is the error code.

RED LIGHT	
ERROR CODE	DESCRIPTION
1	Motor is operating under very low load conditions. This indicates that the pump is probably running dry. System may need filling or air purged.
2	Pump cannot start. Rotor might be blocked. Remove head of pump and check if the impeller turns freely.
3	Motor has overheated. Too hot of a medium, over estimated head of pump requirements or nonfunctioning motor.
4	Frequency converter error.
5	Stator or rotor faulty.

7.2 Overload Effects and Reset:

Overload is indicated by the blue power light changing to red. The red overload light flashes in accordance to the failure. The last overload is saved in memory.

OVERLOAD EFFECTS AND RESET		
DESCRIPTION	OVERLOAD EFFECT	RESET REQUIREMENT
Low Load (dry run)	Pump runs at reduced speed after approx 60 seconds.	Runs at normal speed once motor load is increased (water in volute).
Overload (locked rotor)	Pump shuts off.	Manual (turn main power supply off/on). Clear obstructions if necessary.
Motor Overheat	Pump runs at reduced power until motor cools down.	Cool motor.
VFD Failure	Pump shuts off.	Manual (turn main power off/on). If unable to reset, replace pump (powerhead).
Motor/Stator Failure	Pump shuts off.	Manual (turn main power off/on). If unable to reset, replace pump (powerhead).

8. SEARCH FOR A "LOST PUMP":

If you have forgotten the IP address or NetBIOS name or if you accidentally set it to an incorrect value, a pump can still be found with network analyzers. Freeware tools like "WireShark" or "EtherDetect" can help you to trace the pump as it periodically tries to contact its twin. This is true even in the case of a single pump. You can trace out the device that sends out requests and contact it directly.

9. PARALLEL (MAIN/STANDBY) INSTALLATION:

Prior to connecting the pumps via the Ethernet **Crossover** cable, program each pump's "Pump IP address" and "Twin mode with IP" addresses. See 9.1 and 9.2 below.

NOTE: It is highly recommended that if the pump IP address (and/or the Net BIOS name) is modified from factory default settings then these changes are recorded and the change is posted on the pump itself.

Reprogramming the pumps needs to be completed to each pump individually prior to connecting the pumps together. See Section 6, Subsection 6.6 **Network Settings**. A standard Ethernet or Ethernet Crossover cable can be used to reprogram each pump.

Once completed:

- One pump will run and show a blue light.
- The second pump will be on standby mode indicated by a flashing blue light (drive is enabled and the motor is disabled).
- An automatic alternation between the two pumps will occur every 24 run-hours. This is not adjustable and is a factory default.

To confirm communication between the pumps once reprogramming is complete and the Ethernet Crossover is connected:

- Observe the blue power lights on the face of the drives. One is on constantly and the other pulses.
- Observe the two communication lights at the RJ-45 Ethernet connection in each pump's terminal box. Both pumps should have one LED on continually with the second LED pulsing (indicating intercommunication).
- To confirm communication, turn off the main power supply to the running pump. After 10 to 15 seconds, the second pump will switch from standby to on (flashing blue light changes to solid blue and the motor starts).
- Once communication is confirmed, turn on the power prior to leaving the job site. This pump will now be in standby mode (flashing blue light).

Notes:

Both pumps should be the same size and "Head Max" and "Proportional %" set to the same value. See Section 6, Subsection 6.5 **Pump Settings**.

This is main/standby operation only. Both pumps will not run at the same time as long as the Ethernet Crossover cable is connected.

9.1 IP Settings for Main/Standby Operation – P1:

The screenshot shows the 'Network connection settings' page for a VR 15 pump. The interface includes a navigation menu with 'Overview', 'Pump', 'Network', 'Log', and 'Help'. The main content area is divided into two columns. The left column contains descriptive text for various settings: 'IP address' (192.168.0.246), 'Subnet mask' (255.255.0.0), 'Default gateway' (192.168.0.1), 'NetBIOS name' (VIRIDIAN), and 'Twin mode IP' (192.168.0.246). The right column contains the same settings as input fields with a 'Save' button at the bottom. A 'Save' button is also present at the bottom of the right column.

9.2 IP Settings for Main/Standby Operation – P2:

This screenshot is identical to the one in 9.1, showing the 'Network connection settings' page for a VR 15 pump. It displays the same configuration fields: Pump IP address (192.168.0.246), Subnet mask (255.255.0.0), Default gateway (192.168.0.1), NetBIOS name (VIRIDIAN), and Twin mode with IP (192.168.0.246). The interface includes a 'Save' button and a warning note at the bottom: '(!)Use 'Save' carefully. Incorrect settings might render pump unreachable. If you change the IP address, you will need to manually enter it into browser window.'

10. VIRIDIAN WIRELESS ROUTER SETTINGS:

The following are instructions to set up an external wireless router to communicate with a Viridian Pump.

Follow the instructions that came with the router to perform modifications required in LAN settings and wireless settings.

Shown here is the Netgear WNDR3700, but many routers have similar interfaces. **Note that this will NOT provide internet service to your laptop or mobile device NOR will it make the Viridian accessible over the internet.**

10.1 Wireless Setting:

This is where it is possible to personalize the name of the wireless network. The example below illustrates a network called "Viridian Wireless". Regardless of the wireless network name, once set-up, the wireless device (iPhone, iPad, PC, Mac or Android device) is directed to connect to that network ("Viridian Wireless" as an example).

The screenshot shows the 'Wireless Setup' page in the Netgear genie interface for a WNDR3700v3 router. The 'Region Selection' is set to 'North America'. Under 'Wireless Network (2.4GHz b/g/n)', 'Enable Wireless Isolation' is unchecked, and 'Enable SSID Broadcast' is checked. The 'Name (SSID)' is set to 'Viridian Wireless' and the 'Mode' is 'Up to 145 Mbps'. Under 'Security Options', 'None' is selected. There are also options for 'Wireless Network (5GHz a/n)' which are currently disabled. The interface includes a 'Help Center' link and a 'SEARCH HELP' field at the bottom.

10.2 LAN (Local Area Network) Setting:

The factory default IP Address of the Viridian is 192.168.0.245. It is not necessary to change this unless multiple Viridians are connected to the same router. See Notes below.

Set Router LAN TCP/IP as follows:

- IP Address 192.168.0.1
- IP Subnet mask 255.255.255.0

Set Router DHCP as follows:

- Check “Use Router as DHCP Server” box
- Starting IP Address 192.168.0.2
- Ending IP Address 192.168.0.100



10.3 Steps to Communicate with the Viridian After Changes are Complete:

Plug in an Ethernet cable to the device input at the back of the router (not the Internet or “WAN” input) and to the Ethernet connection at the Viridian.

Power up all devices (the Viridian can be forced into standby by placing a jumper across I01 and 0V digital input to eliminate dry operation of the rotating assembly).

Connect to the wireless network with the iPhone (or other wireless device), using the network name set in the “Wireless Setting” section. Open up the device web software (Safari, Windows Explorer, Firefox etc.).

Open the website “Viridian” or enter the pump’s IP Address 192.168.0.245 in the address window, click enter.

Connection is complete and status or adjustments to the Viridian can be made.

Notes:

Multiple Viridians can be plugged into the router, although each pump would require a different IP address and name.

No other changes to the router are required from factory settings.

11. SPECIFICATIONS AND PUMP CHARACTERISTICS:

11.1 Application:

- Maximum Operating Pressure: 175 PSI (12 bar)
- Water Temperature Range: 14° – 230°F (-10° – 110°C)
- Ambient Operation Temperature Range: 32° – 104°F (0° – 40°C). Ambient temperature should be 104°F (40°C) or lower when fluid temperature exceeds 194°F (90°C).
- Minimum static inlet pressure at pump suction port (PSI / bar) to avoid cavitation at fluid temperatures:

FLUID TEMPERATURES	VR15 & VR20 (PSI / bar)	VR25 & VR30 (PSI / bar)
112°F (50°C)	7.3 / 0.5	4.35 / 0.3
176°F (80°C)	11.6 / 0.8	14.5 / 1.0
230°F (110°C)	20.3 / 1.4	23.2 / 1.6

- Designed for closed loop heating and cooling systems pumping water or a water/glycol mixture.
- For indoor use only - employer uniquement a l'interieur.

11.2 Electrical Data:

- Pump Ratings: 1 phase, 110 - 240V, 47 - 63Hz (VR15 & VR20)
1 phase, 200 - 240V, 47 - 63Hz (VR25 & VR30)
- Power Consumption (HP): VR15 = 0.027 - 0.680 HP
VR20 = 0.035 - 1.088 HP
VR25 = 0.054 - 1.496 HP
VR30 = 0.054 - 2.175 HP
- Power Consumption (W): VR15 = 20 - 500 W
VR20 = 26 - 800 W
VR25 = 46 - 1100 W
VR30 = 40 - 1600 W
- Rated Current (1 phase, 115/230V): VR15 = 2.2 A - 6.0 A
VR20 = 3.5 A - 6.0 A
- Rated Current (1 phase, 230V): VR25 = 8.0 A
VR30 = 8.0 A
- 24V Supply Output: Max. Current up to 100 mA,
Output Voltage of 24V ± 20%,
Output Ripple under 1V
- Relay Output: 8A, Max. Voltage 250 VAC, 48 VDC
Max. Load up to 500 VA
- Digital Inputs: Max. Input Voltage = 32VDC
Input Impedance ~5kΩ
Logical »1« Voltage > 8V
Logical »0« Voltage < 2V
Insulation to Supply Voltage = 4kV @ 1s,
275V permanent

- Continuous Duty
- Built-in Startup Circuit

11.3 Standards, Protection and Connection:

- Insulation: Class H
- Enclosure: Class 2, IP44
- Integrated Motor Protection (electronically protected)
- UL 778, 1004-1, 508C
- CAN/CSA C22.2 #108, #100, #107.1
- EMC (89/366 EEC): EN 61000
- LVD (73/23/EC): EN 60335-1, EN 60335-2-51
- Machine Safety (98/37/EC): EN ISO 12100
- Flange Connections: ANSI 4-bolt

11.4 Ethernet Specifications:

- Connector: RJ-45 Ethernet Cable
- Speed: BASE-10, 10 Mbit/s
- Galvanic Insulation to Digital Inputs: 1.5kV @ 1s, 48V permanent
- Galvanic Insulation to Line Voltage: 4kV @ 1s, 275V permanent
- Connections: TCP/IP
- Services: http server and client, FTP server
- Web Language: HTML 1.1

11.5 Materials of Construction:

- Casing: Cast Iron
- Impeller: Stainless Steel
- Shaft: Stainless Steel
- Bearing: Metal Impregnated Carbon

11.6 Operating Modes:

- Constant Pressure Control (Δp-c)
- Variable Differential Pressure Control (Δp-v) - factory default
- Proportional Pressure Control
- Constant Curve Duty (uncontrolled pump)
- RPM Regulation
- Power Limitation

11.7 Additional Operating Modes for Two Pumps in Parallel:

- Alternating Operation (every 24 hours)
- Standby Operation

11.8 Communication:

- Web Interface (data exchange)
- XML Control Transfer Protocol
- External Digital Input/Output: 2 Inputs & 1 Output

VIRIDIAN 15-30 PERFORMANCE CURVES

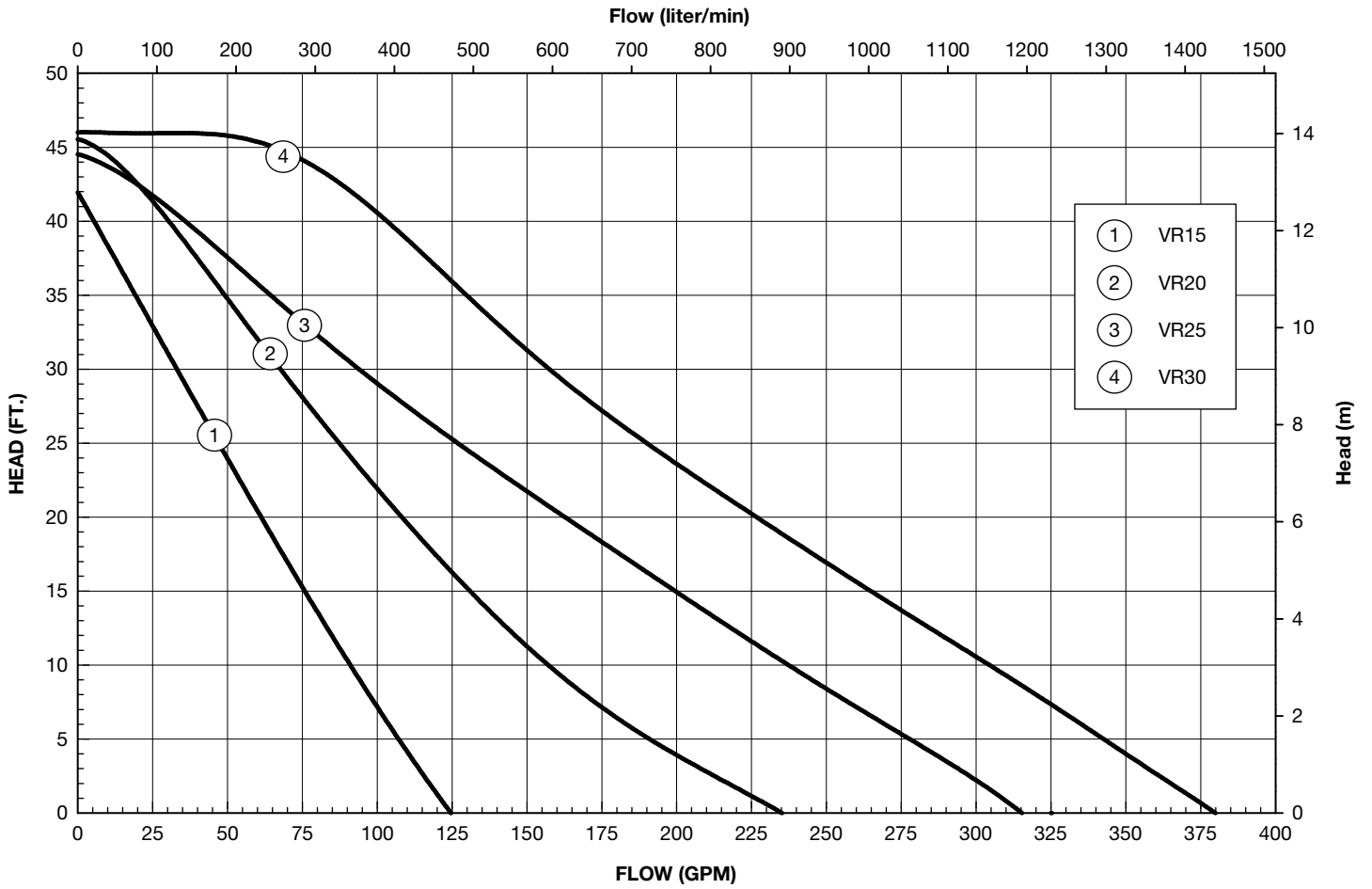

NOTES:

NOTES:

LIMITED WARRANTY STATEMENT

Taco, Inc. will repair or replace without charge (at the company's option) any product or part which is proven defective under normal use within one (1) year from the date of start-up or one (1) year and six (6) months from date of shipment (whichever occurs first).

In order to obtain service under this warranty, it is the responsibility of the purchaser to promptly notify the local Taco stocking distributor or Taco in writing and promptly deliver the subject product or part, delivery prepaid, to the stocking distributor. For assistance on warranty returns, the purchaser may either contact the local Taco stocking distributor or Taco. If the subject product or part contains no defect as covered in this warranty, the purchaser will be billed for parts and labor charges in effect at time of factory examination and repair.

Any Taco product or part not installed or operated in conformity with Taco instructions or which

has been subject to misuse, misapplication, the addition of petroleum-based fluids or certain chemical additives to the systems, or other abuse, will not be covered by this warranty.

If in doubt as to whether a particular substance is suitable for use with a Taco product or part, or for any application restrictions, consult the applicable Taco instruction sheets or contact Taco at [401-942-8000].

Taco reserves the right to provide replacement products and parts which are substantially similar in design and functionally equivalent to the defective product or part. Taco reserves the right to make changes in details of design, construction, or arrangement of materials of its products without notification.

TACO OFFERS THIS WARRANTY IN LIEU OF ALL OTHER EXPRESS WARRANTIES. ANY WARRANTY IMPLIED BY LAW INCLUDING WARRANTIES OF MERCHANTABILITY OR

FITNESS IS IN EFFECT ONLY FOR THE DURATION OF THE EXPRESS WARRANTY SET FORTH IN THE FIRST PARAGRAPH ABOVE.

THE ABOVE WARRANTIES ARE IN LIEU OF ALL OTHER WARRANTIES, EXPRESS OR STATUTORY, OR ANY OTHER WARRANTY OBLIGATION ON THE PART OF TACO.

TACO WILL NOT BE LIABLE FOR ANY SPECIAL, INCIDENTAL, INDIRECT OR CONSEQUENTIAL DAMAGES RESULTING FROM THE USE OF ITS PRODUCTS OR ANY INCIDENTAL COSTS OF REMOVING OR REPLACING DEFECTIVE PRODUCTS.

This warranty gives the purchaser specific rights, and the purchaser may have other rights which vary from state to state. Some states do not allow limitations on how long an implied warranty lasts or on the exclusion of incidental or consequential damages, so these limitations or exclusions may not apply to you.

COMFORT MADE EASY[®]

TACO, INC., 1160 Cranston Street, Cranston, RI 02920 Telephone: (401) 942-8000 FAX: (401) 942-2360.

TACO (Canada), Ltd., 8450 Lawson Road, Unit #3, Milton, Ontario L9T 0J8. Telephone: 905/564-9422. FAX: 905/564-9436.

Visit our web site at: <http://www.taco-hvac.com>

Printed in USA

Copyright 2013

TACO, Inc.