



Instruction Sheet

Plus Two Multi-Purpose Valve (MPV)

302-040

SUPERSEDES: New

EFFECTIVE: June 1, 2005

Plant ID No. 001-3881



CAUTION: THIS VALVE IS A CHECK VALVE. DEPRESSURIZE BOTH SIDES OF VALVE BEFORE SERVICING THIS PRODUCT OR ATTACHED PIPING.



WARNING: FAILURE TO COMPLY WITH THESE INSTRUCTIONS REGARDING THIS VALVE CAN RESULT IN SERIOUS PERSONAL INJURY OR DEATH AND/OR SEVERE PROPERTY DAMAGE.

INTRODUCTION/APPLICATION

The Taco Plus Two Multi-Purpose Valve incorporates all of the functions required on the discharge side of a pump in a Hydronic System into one valve. It is a spring loaded non slam check valve, a shut off valve, a flow control valve and a flow metering valve.

Each valve has a calibrated nameplate for system balancing (approximate). All valves are equipped with metering ports for taking differential pressure readings that can be used with corresponding flow charts for more accurate system balance.

OPERATING LIMITATIONS

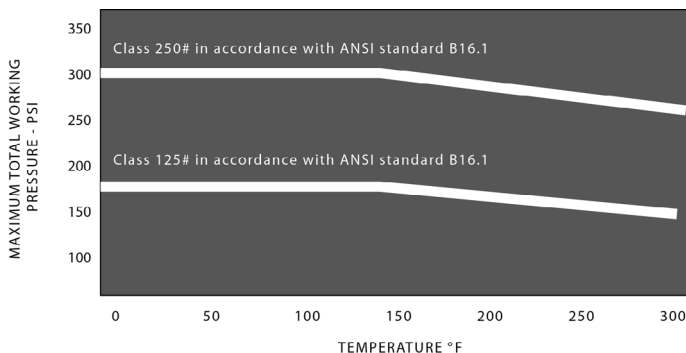

INSTALLATION

1. The Taco Plus Two Multi-Purpose Valve should be mounted to a spool piece on the discharge side of the pump. It is recommended that a spool piece of 12" be used on pumps with a discharge size of 1.5" through 6" and a 24" spool piece be used for discharge sizes 8" through 12".
2. In order to prevent any objectionable system noise, mounting of the valve directly to the pump *is not* recommended.
3. Provide sufficient clearance around the valve to facilitate removal or repair.
4. Valve should be installed in the direction of the flow arrows on the valve body.
5. The valve body is not designed to support the weight of the system piping. Pipe hangers must be used and properly installed in accordance with accepted industry standards/practice. Pipe supports should be provided under the valve bodies.

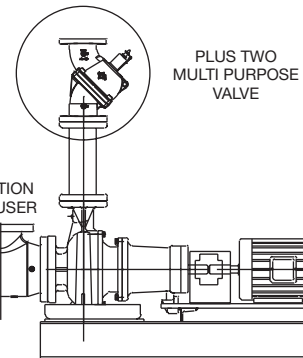

BASE MOUNTED SINGLE SUCTION PUMP

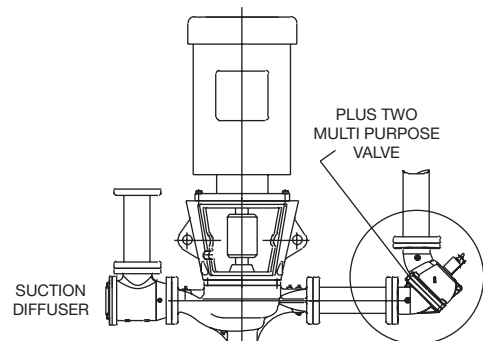

VERTICAL IN - LINE PUMP

FIELD CONVERSION (straight to angle pattern)



WARNING: Valve components can be very heavy, employ proper lifting equipment when working on valves. Failure to follow these instructions can result in serious personal injury or death and property damage.

1. Open valve a minimum of one complete turn.
2. Remove the body bolts.
1.5" through 2.5" size valves require a 3/8" allen key.
3" valve requires a 1/2" allen key.
4" valve requires a 5/8" allen key.
5" and 6" valves require 3/4" allen key.
8" through 12" valves are 3/4" **hex cap bolts**.
3. Rotate one half of valve body 180° while ensuring that

the body “O” ring and the “soft seat” remain in position (inspect the body “O” ring and the “soft seat” for any nicks or cuts and replace as necessary).

4. Reinstall the body bolts and torque to 50 ft lbs.

REPLACING STEM PACKING



WARNING: Hot system fluid leaking from valves can cause burns. Avoid contact with leaking system fluid when servicing any valve. Failure to follow this instruction can result in serious personal injury or death and property damage.



CAUTION: Safety glasses should be worn.

If a leak develops at the stem packing nut, turn nut clockwise until the leak stops.

If the leak persists you will need to replace the stem packing, this may be accomplished while valve is under full system pressure.

1. Record valve setting utilizing memory clip.
2. Remove retaining rings and calibration name plate.
3. Turn valve stem counter-clockwise until the valve is fully open and will not turn any further.
4. Remove packing nut, located at base of stem by turning counter clockwise.
5. Remove old packing and replace it with two new packing rings with the ring joints positioned 180 degrees apart.
6. Replace packing nut and tighten as required.
7. Reinstall calibration name plate and retaining rings.
8. Reposition valve stem per recorded setting in step one.



WARNING: Hot water leakage can occur from readout valves during hookup of readout kit. Follow the instructions in instruction manuals supplied with readout kits for safe use. Keep eyes protected with safety glasses. Make sure that readout valves are not leaking before removing safety cap. Failure to follow this instruction can result in serious personal injury or death and property damage.

FLOW METER OPERATION

1. Remove caps from the valves at the HI and LO pressure taps.
2. Connect the high pressure hose (red) of the differential pressure gauge to the upstream of HI pressure connection on the MPV and the low pressure hose (green) to the downstream of LO pressure connection.
Note: Hose ends to be connected require valve depressors. Check opposite end of hose if not visible inside hose end. Valves are opened automatically as the hose end is screwed on.
3. Prepare the differential pressure gauge as per instructions in the Gauge Kit.
4. The flow can be determined by reading the differential pressure indicated at the gauge, noting the valve opening from the scale and pointer and transferring this data to the Flow Chart (published separately).
5. When flow readings are complete, follow directions supplied with differential pressure gauge.
6. Replace metal caps on valves at the HI and LO pressure taps.

NOTE: In order to achieve optimal accuracy when using any differential pressure flow measuring device, it is recommended that a minimum of 10 diameters of straight pipe (sized to the device) be installed upstream of the device and a minimum of 5 diameters of straight pipe be installed downstream of the device.

LIMITED WARRANTY STATEMENT

Taco, Inc. will repair or replace without charge (at the company's option) any product or part which is proven defective under normal use within one (1) year from the date of start-up or one (1) year and six (6) months from date of shipment (whichever occurs first).

In order to obtain service under this warranty, it is the responsibility of the purchaser to promptly notify the local Taco stocking distributor or Taco in writing and promptly deliver the subject product or part, delivery prepaid, to the stocking distributor. For assistance on warranty returns, the purchaser may either contact the local Taco stocking distributor or Taco. If the subject product or part contains no defect as covered in this warranty, the purchaser will be billed for parts and labor charges in effect at time of factory examination and repair.

Any Taco product or part not installed or operated in conformity with Taco instructions or which

has been subject to misuse, misapplication, the addition of petroleum-based fluids or certain chemical additives to the systems, or other abuse, will not be covered by this warranty.

If in doubt as to whether a particular substance is suitable for use with a Taco product or part, or for any application restrictions, consult the applicable Taco instruction sheets or contact Taco at [401-942-8000].

Taco reserves the right to provide replacement products and parts which are substantially similar in design and functionally equivalent to the defective product or part. Taco reserves the right to make changes in details of design, construction, or arrangement of materials of its products without notification.

TACO OFFERS THIS WARRANTY IN LIEU OF ALL OTHER EXPRESS WARRANTIES. ANY WARRANTY IMPLIED BY LAW INCLUDING WARRANTIES OF MERCHANTABILITY OR

FITNESS IS IN EFFECT ONLY FOR THE DURATION OF THE EXPRESS WARRANTY SET FORTH IN THE FIRST PARAGRAPH ABOVE.

THE ABOVE WARRANTIES ARE IN LIEU OF ALL OTHER WARRANTIES, EXPRESS OR STATUTORY, OR ANY OTHER WARRANTY OBLIGATION ON THE PART OF TACO.

TACO WILL NOT BE LIABLE FOR ANY SPECIAL, INCIDENTAL, INDIRECT OR CONSEQUENTIAL DAMAGES RESULTING FROM THE USE OF ITS PRODUCTS OR ANY INCIDENTAL COSTS OF REMOVING OR REPLACING DEFECTIVE PRODUCTS.

This warranty gives the purchaser specific rights, and the purchaser may have other rights which vary from state to state. Some states do not allow limitations on how long an implied warranty lasts or on the exclusion of incidental or consequential damages, so these limitations or exclusions may not apply to you.

Do it Once. Do it Right.™

TACO, INC., 1160 Cranston Street, Cranston, RI 02920 Telephone: (401) 942-8000 FAX: (401) 942-2360.
TACO (Canada), Ltd., 6180 Ordan Drive, Mississauga, Ontario L5T 2B3. Telephone: 905/564-9422. FAX: 905/564-9436.

Visit our web site at: <http://www.taco-hvac.com>

Printed in USA
Copyright 2005
TACO, Inc.