



# Instruction Sheet

## TacoGenie® Under Sink Installation

102-577











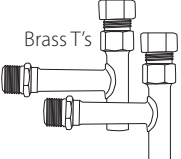



SUPERSEDES: December 1, 2015

EFFECTIVE: September 9, 2022

Plant ID# 001-5045

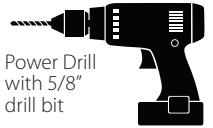
### Installation for the TacoGenie in an Under Sink Installation

Installation shall be in accordance with the manufacturer's instructions or warranty may be voided

Taco Genie Includes:	Tools Required for installation:
 Round Starter Button  Brass T's  TacoGenie® IFC® Circulator (Options) • 006/008us • 0011usk  Flex Line Hose Kit  TITLE 24 CALIFORNIA  NSF Certified to NSF/ANSI/CAN 61 & 372  UL LISTED	 Wrench  Pliers  Wire Stripper  Screwdrivers  Power Drill with 5/8" drill bit  Teflon Tape  Electrical Tape or Wire Nuts 

### IMPORTANT

Operation of the TacoGenie without being plumbed into water lines may damage the pump and void the warranty.

**WARNING:** In the event the retaining screws have been pulled out of the housing, DO NOT replace them. Use of any other screw may short out the stator windings, creating a risk of electrical shock.

**WARNING:** To avoid electrical shock, disconnect the power supply to the circulator and the main electrical unit

**CAUTION:** When installing electrical connections, do not apply mechanical loads to the electrical box; otherwise, retaining screws may be pulled out of the housing, making circulator unusable.

### NOTE:

T's and flex lines supplied by Taco provide maximum flow and performance. Alternative plumbing parts may restrict flow and delay hot water to fixtures.

### Pump Position:

Pump should always be installed in a horizontal position with TacoGenie capacitor box facing up toward the sink. Be sure arrow on pump casing is pointing from left to right (hot water to cold water side) prior to connecting the flex lines.

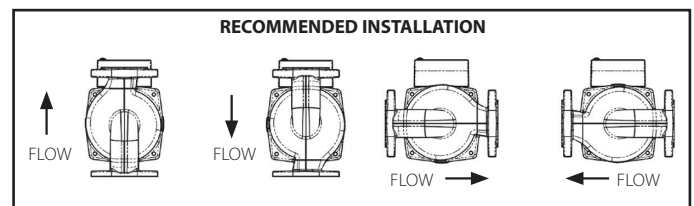

### Optional Accessories

Round Starter Button (554-3)	Wireless Remote Receiver Kit (554-7)	Wireless Remote Transmitter Button (554-8)	Motion Sensor (554-4)

### For Undersink Installation:

Typically, this would be at the fixture farthest away from the water heater, generally the kitchen or master bath room. If your hot water supply runs in two different directions from the water heater, you may need more than one TacoGenie.

## Installation for CT-Series TacoGenie Models 006-CT-USK, 008-CT-USK and 0011-CF-USK

The two custom adapter "T"s are designed to simplify your installation to 1/2 inch copper hot and cold supply lines. If you have plumbing other than as shown in these instructions, additional fittings may be required. Consult a plumbing professional.

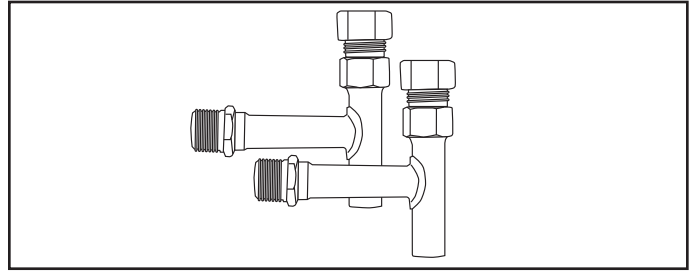

### ELECTRICAL SUPPLY:

A 110V electrical supply outlet is required to power the TacoGenie unit. If an outlet is not available, install a 110V outlet in accordance with all local electrical codes. Caution: Do not plug in the TacoGenie until all plumbing and wiring connections are completed and water supply is turned on. Running the circulating pump without water may damage internal components and void warranty.



**CAUTION: Do not plug in the TacoGenie until all plumbing and wiring connections are completed and water supply is turned on. Running the circulating pump without water may damage internal components and void warranty.**



**WARNING: To prevent scalding, use caution when removing valve on hot water line**

### Plumbing instructions using USK- Plumbing adapter Kit

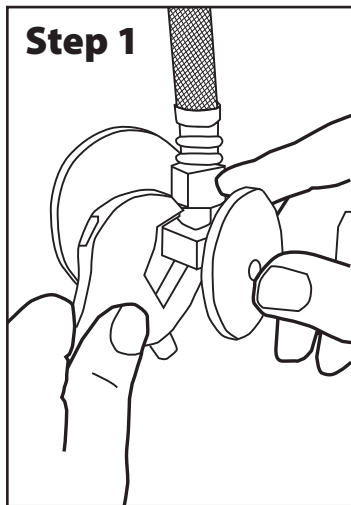

Turn off water supply and remove angle stops.

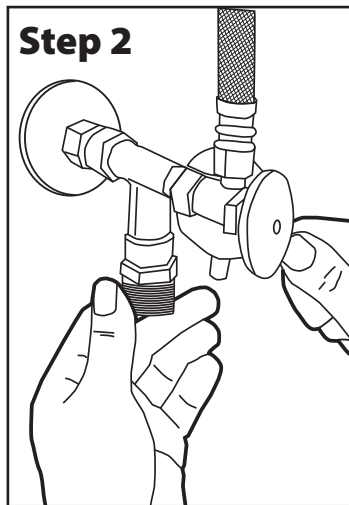

Install tees and attach angle stops.

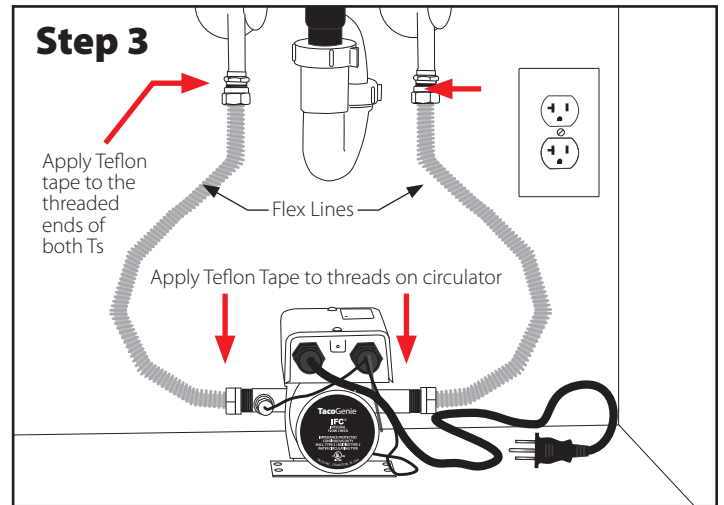

Apply teflon tape to threaded ends. Connect the flex lines to the tees, and to the TacoGenie Circulator.

**NOTE: If starter button will not be used, be sure to use electrical tape or wire nuts to isolate the leads on the gray wire.**

### Step 4

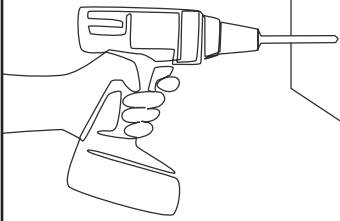

Drill a 5/8" hole into side or front of a vanity cabinet.

### Step 5

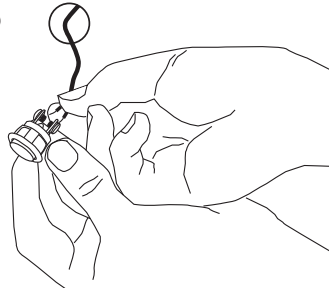

Connect gray wire to the starter button.

### Step 6

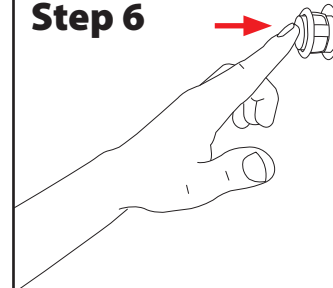

Firmly insert the button into the drilled hole.

### Step 7

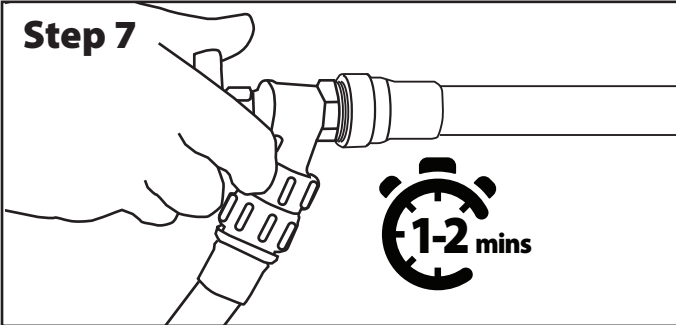

Check for leaks, flush system for 1-2 minutes.

### Step 8

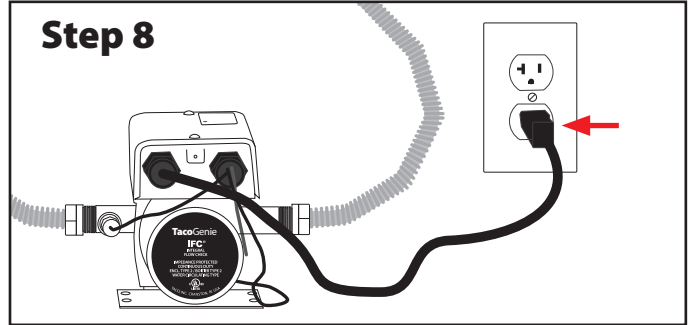

Plug in the TacoGenie. The pump will start automatically the first time only and run until a rise in temperature is detected by the thermal sensor. Pump will automatically shut off. Pump will be disabled when senses water temperature above 100°F.

### Step 9

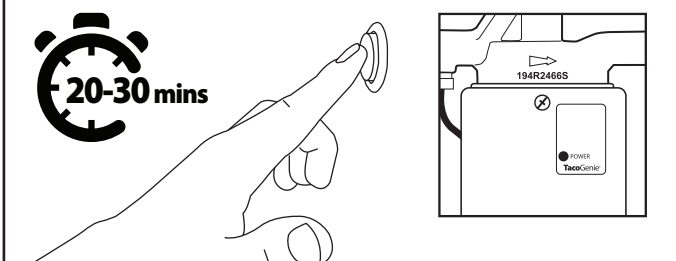

To test manual starter button, wait for hot water temperature to cool below 100°F (approx. 20-30 minutes). Push start button. The TacoGenie should run for a short time and shut off automatically.

### Step 10



Check hot water at the fixture for desired temperature. If hot water temperature is not satisfactory, refer to the Troubleshooting checklist section.

# Installation Diagram

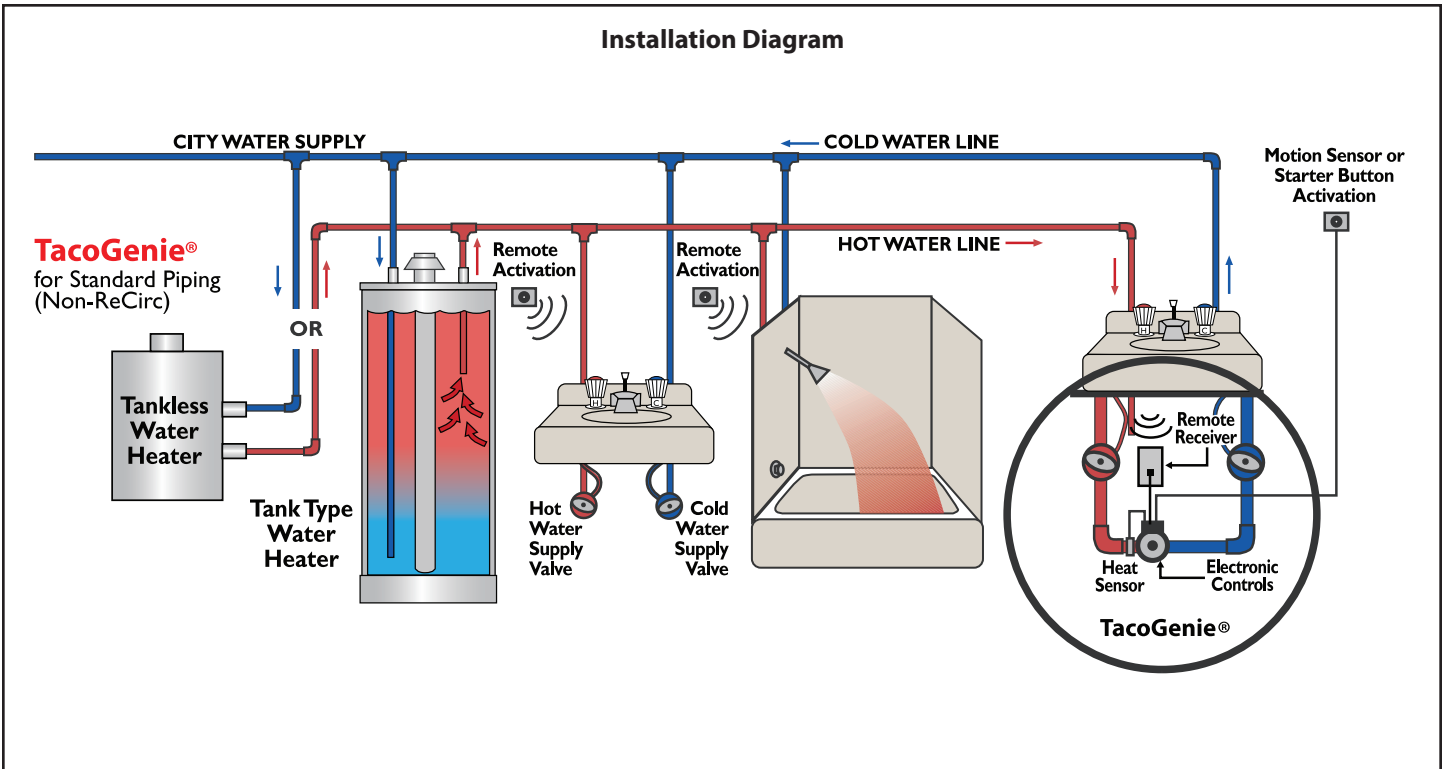

## TROUBLESHOOTING – DIAGNOSING SPECIFIC PROBLEMS

PROBLEM	POSSIBLE CAUSE	REMEDY
The pump does not run when push button is pressed. Green LED does not illuminate.	No power at electrical outlet  You've plugged the controller into an electrical outlet controlled by a wall switch, (such as the outlet under many kitchen sinks that controls	Plug the controller into a working outlet
	Power cord is not secured to pump  Wire to push button is not connected well	Shut off power, then make sure wires have good contact
	The temperature setting is already sensing "hot" water so the pump is not being activated	Call Taco Technical Service 1-401-942-8000
The water is not hot enough.	Pump was installed with water flow going in the wrong direction  There is something in the piping that has blocked the flow of water	Check the arrows on the pump casing to make sure they point in the correct direction (see page 2)  Check the piping for obstruction
There is hot water at the cold water tap.	The water temperature sensor is loose or dislodged  The temperature sensitivity setting now in place is too low, so the pump is not shutting down soon enough	Check the connection of the water temperature sensor to make sure it is firmly attached to the plug and casing  Call Taco Technical Service 1-401-942-8000
Water is not hot enough when pump shuts down.	The temperature sensitivity setting now in place is too high, and the pump is turning itself off too soon	Call Taco Technical Service 1-401-942-8000
There is hot water in the cold water lines only	The pump is installed backwards	Reinstall the pump correctly

## REPLACEMENT PARTS

Pump Model #	Casing O-Ring	Flange Gasket Set	Capacitor or PC Board	Cartridge Assy. Complete	Valve Assy. Trans/Relay
006-CT	007-003RP	---	006-055RP	005-020RP	006-051RP
008-CT	008-005RP	---	006-055RP	008-045RP	006-051RP
0011-CF	009-028RP	007-007RP	006-055RP	0011-010RP	0011-021RP

## TacoGenie Button & Wireless Receiver Wiring Application

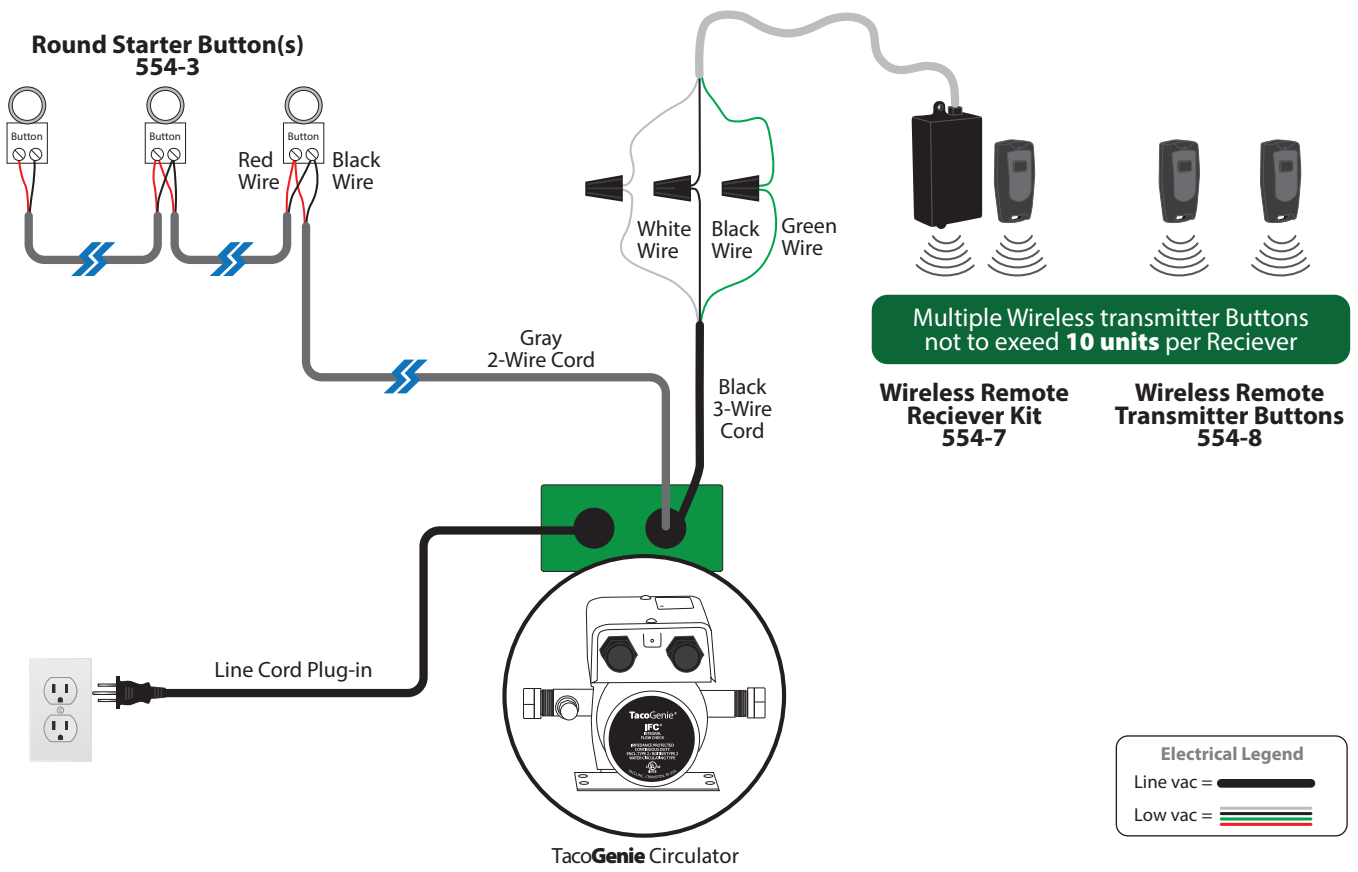

### TacoGenie Button & Motion Sensor Wiring Application

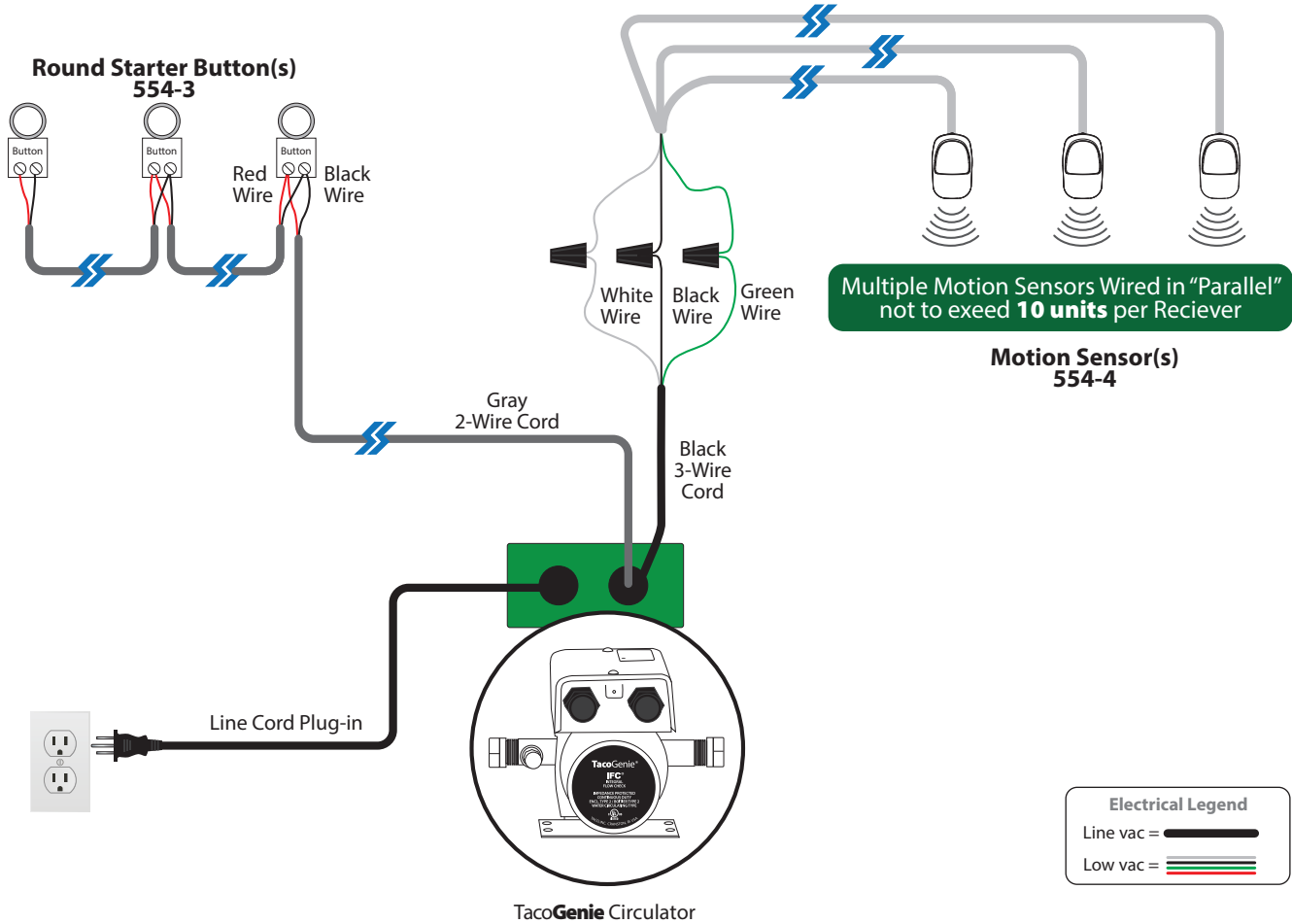

## TacoGenie Button & Motion Sensor & Wireless Receiver Wiring Application

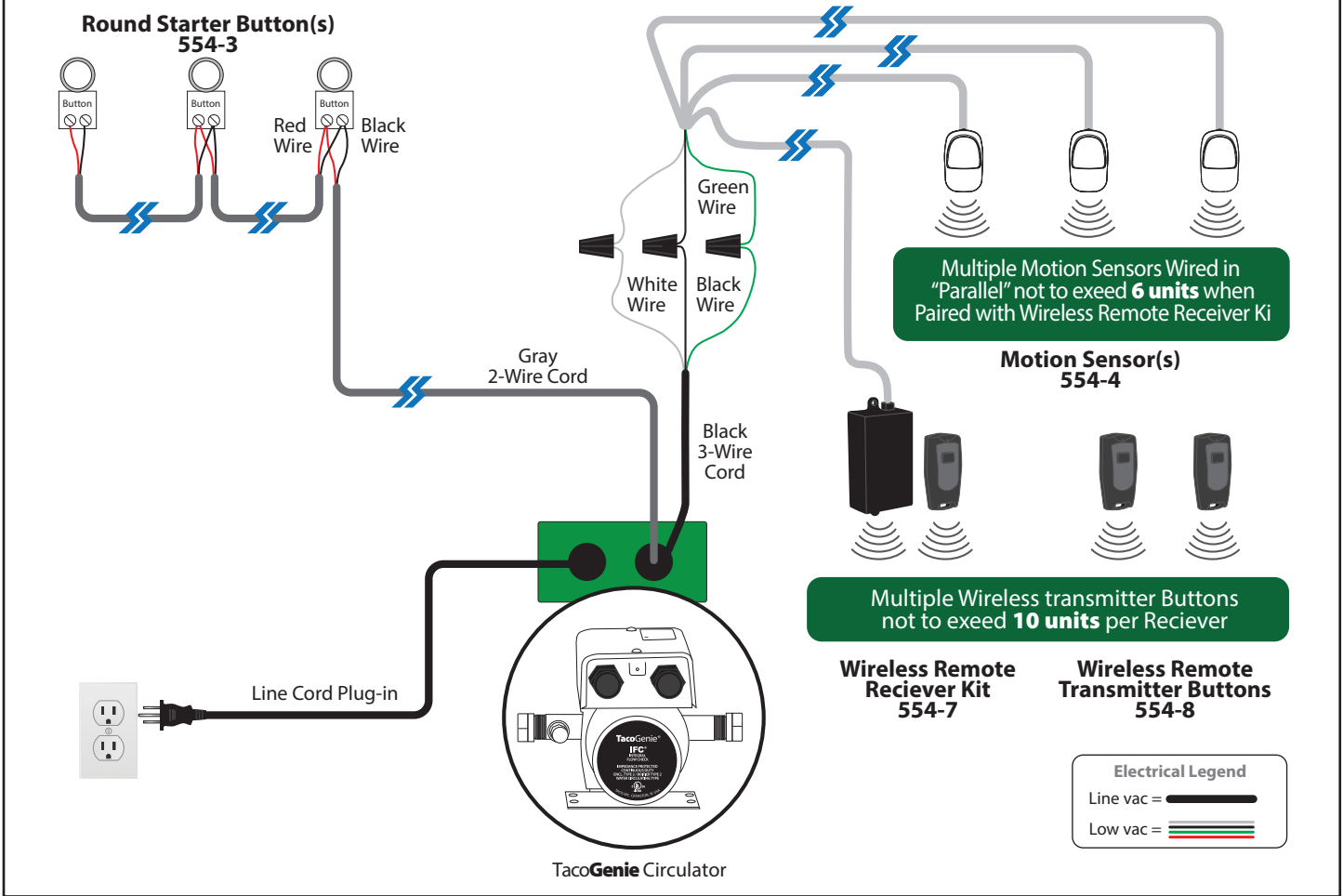

## LIMITED WARRANTY STATEMENT

Taco, Inc. will repair or replace without charge (at the company's option) any Taco product which is proven defective under normal use within three (3) years from the date code.

In order to obtain service under this warranty, it is the responsibility of the purchaser to promptly notify the local Taco stocking distributor or Taco in writing and promptly deliver the subject product or part, delivery prepaid, to the stocking distributor. For assistance on warranty returns, the purchaser may either contact the local Taco stocking distributor or Taco. If the subject product or part contains no defect as covered in this warranty, the purchaser will be billed for parts and labor charges in effect at time of factory examination and repair.

Any Taco product or part not installed or operated in conformity with Taco instructions or which has been subject to misuse, misapplication, the addition of petroleum-based fluids or certain chemical

additives to the systems, or other abuse, will not be covered by this warranty.

If in doubt as to whether a particular substance is suitable for use with a Taco product or part, or for any application restrictions, consult the applicable Taco instruction sheets or contact Taco at (401-942-8000).

Taco reserves the right to provide replacement products and parts which are substantially similar in design and functionally equivalent to the defective product or part. Taco reserves the right to make changes in details of design, construction, or arrangement of materials of its products without notification.

**TACO OFFERS THIS WARRANTY IN LIEU OF ALL OTHER EXPRESS WARRANTIES. ANY WARRANTY IMPLIED BY LAW INCLUDING WARRANTIES OF MERCHANTABILITY OR FITNESS IS IN EFFECT ONLY FOR THE DURATION OF THE EXPRESS WARRANTY SET FORTH IN THE FIRST PARAGRAPH ABOVE.**

**THE ABOVE WARRANTIES ARE IN LIEU OF ALL OTHER WARRANTIES, EXPRESS OR STATUTORY, OR ANY OTHER WARRANTY OBLIGATION ON THE PART OF TACO.**

**TACO WILL NOT BE LIABLE FOR ANY SPECIAL INCIDENTAL, INDIRECT OR CONSEQUENTIAL DAMAGES RESULTING FROM THE USE OF ITS PRODUCTS OR ANY INCIDENTAL COSTS OF REMOVING OR REPLACING DEFECTIVE PRODUCTS.**

This warranty gives the purchaser specific rights, and the purchaser may have other rights which vary from state to state. Some states do not allow limitations on how long an implied warranty lasts or on the exclusion of incidental or consequential damages, so these limitations or exclusions may not apply to you.

**Taco Comfort Solutions**® A Taco Family Company

**Taco, Inc.**, 1160 Cranston Street, Cranston, RI 02920 | Tel: (401) 942-8000

**Taco (Canada), Ltd.**, 8450 Lawson Road, Suite #3, Milton, Ontario L9T 0J8 | Tel: (905) 564-9422

Visit our web site: [www.TacoComfort.com](http://www.TacoComfort.com) | ©2022 Taco, Inc.

