



Application

This valve is typically used in air handling units on heating or cooling coils, and fan coil unit heating or cooling coils. Some other common applications include Unit Ventilators, VAV box re-heat coils and bypass loops. This valve is suitable for use in a hydronic system with variable or constant flow.

Technical Data	
Service	chilled or hot water, 60% glycol
Flow characteristic	A-port equal percentage B-port modified for constant common port flow
Action	90° rotation
Sizes	½", ¾", 1", 1¼", 1½", 2"
Type of end fitting	NPT female ends
Materials:	
Body	forged brass, nickel plated
Ball	stainless steel
Stem	stainless steel
Seats	PTFE
Characterizing disc	Tefzel®
Packing	2 EPDM O-rings, lubricated
Body Pressure rating	
600 psi	½" - 1"
400 psi	1¼" - 2"
Media temp. range	0°F to 212°F [-18°C to 100°C]
Close off pressure	
200 psi	½" - 2"
Maximum differential pressure (ΔP)	30 psi for typical applications
Leakage	0% for A to AB <2.0% for B to AB
C _v rating	A-port: see product chart for values B-port: 70% of A to AB C _v

Tefzel® is a registered trademark of DuPont

Dimensions

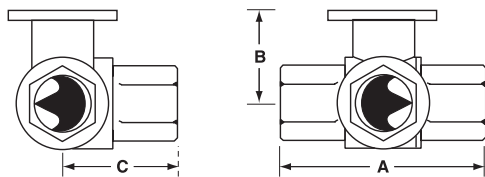

Valve Body	Valve Nominal Size		Dimensions (Inches [mm])		
	Inches	DN [mm]	A	B	C
B307-B311	½"	15	2.41" [61.1]	1.39" [35.2]	1.20" [30.6]
B312-B315	½"	15	2.38" [60.4]	1.72" [43.7]	1.26" [32.1]
B317-B320	¾"	20	2.73" [69.3]	1.81" [45.9]	1.45" [36.8]
B322-B325	1"	25	3.09" [78.4]	1.81" [45.9]	1.56" [39.8]
B329-B331	1¼"	32	3.96" [100.6]	2.21" [56.2]	2.14" [54.3]
B338-B341	1½"	40	4.39" [111.6]	2.45" [62.2]	2.33" [59.1]
B347-B352	2"	50	4.90" [124.5]	2.68" [68.0]	2.60" [66.0]

C _v	Valve Nominal Size		Type	Suitable Return Actuators		
	Inches	DN [mm]		Non-Spring	Spring	
0.3	½"	15	B307	TR Series	LR Series	
0.46	½"	15	B308			
0.8	½"	15	B309			
1.2	½"	15	B310			
1.9	½"	15	B311			
3	½"	15	B312			
4.7	½"	15	B313			
10	½"	15	B315*			
4.7	¾"	20	B317			
24	¾"	20	B320*			
7.4	1"	25	B322	NR...N4 Series	TF Series	
10	1"	25	B323			
30	1"	25	B325*			
10	1¼"	32	B329			
19	1¼"	32	B330			
25	1¼"	32	B331			
19	1½"	40	B338			
29	1½"	40	B339			
37	1½"	40	B340			
46	1½"	40	B341			
29	2"	50	B347	AR Series	AR...N4 Series	
37	2"	50	B348			
46	2"	50	B349			
57	2"	50	B350			
68	2"	50	B351			
83	2"	50	B352			
						AF Series

*Models without characterizing disc

Flow Patterns

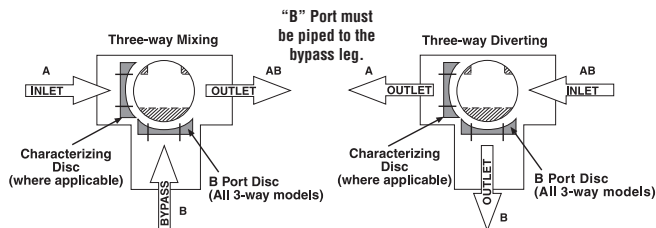



Models

TR24-SR-T US

TR24-SR US	TR24-SR-T US with 3 ft plenum rated cable
TR24-SR/300 US	TR24-SR-T US with 10 ft plenum rated cable
TR24-SR/500 US	TR24-SR-T US with 16 ft plenum rated cable

Technical Data

Control	Proportional
Nominal voltage	24 VAC 50/60 Hz, 24 VDC
Nominal voltage range	19.2...28.8 VAC, 21.6...28.8 VDC
Power consumption	0.5 W
Transformer sizing	1VA (class 2 power source)
Electrical connection	screw terminals accessible after removal of small cover (3 ft, 10 ft, 16 ft cables optional)
Input impedance	100 kΩ
Angle of rotation	90°
Direction of rotation	reversible with switch under cover
Position indication	integrated into handle
Manual override	push down handle
Running time	90 seconds
Humidity	5 to 95% non-condensing
Ambient temperature	-22°F to 122°F (-30°C to 50°C)
Storage temperature	-40°F to 176°F (-40°C to 80°C)
Housing	NEMA 1/IP40
Housing rating	UL94-5V(B)
Agency listing†	cULus acc. to UL60730-1A/-2-14, CAN/CSA E60730-1, CSA C22.2 No. 24-93, CE acc. to 89/336/EEC
Noise level	max. 35 db (A)
Quality standard	ISO 9001

† Rated impulse voltage 500V, Control pollution degree 2, Type of action 1

Dimensions with 2-Way Valve

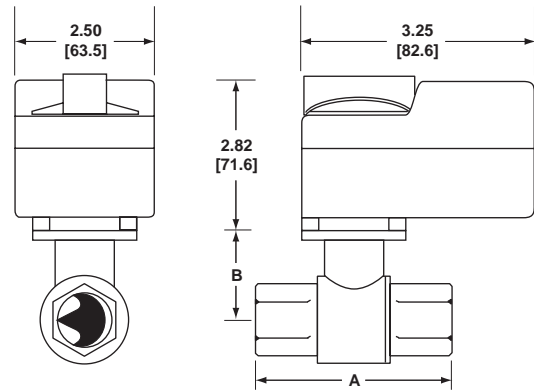

D069

Valve Body	Valve Nominal Size		Dimensions (Inches [mm])	
	Inches	DN [mm]	A	B
B207(B)-B211(B)	½"	15	2.41" [61.1]	1.39" [35.2]
B212(B)-B215(B)	½"	15	2.38" [60.4]	1.72" [43.7]
B217(B)-B220(B)	¾"	20	2.73" [69.3]	1.81" [45.9]

Dimensions with 3-Way Valve

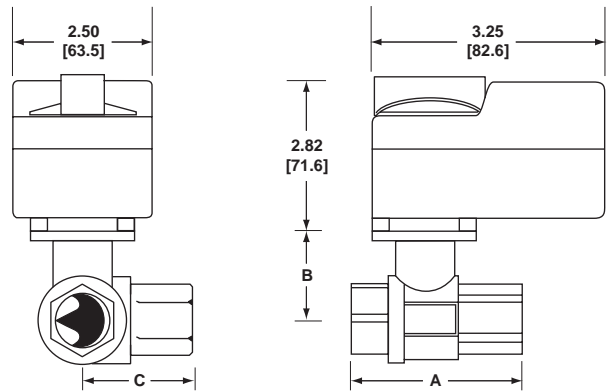

D072

Valve Body	Valve Nominal Size		Dimensions (Inches [mm])		
	Inches	DN [mm]	A	B	C
B307(B)-B311(B)	½"	15	2.41" [61.1]	1.39" [35.2]	1.20" [30.6]
B312(B)-B315(B)	½"	15	2.38" [60.4]	1.72" [43.7]	1.26" [32.1]
B317(B)-B320(B)	¾"	20	2.73" [69.3]	1.81" [45.9]	1.45" [36.8]

Wiring Diagrams

✂️ INSTALLATION NOTES

⚠️ 2 Actuators with color coded wires are optional. Wire numbers are provided for reference.

CAUTION Equipment damage!

Actuators may be connected in parallel. Power consumption and input impedance must be observed.

⚠️ 3 Actuators may also be powered by 24 VDC.

⚠️ WARNING Live Electrical Components!

During installation, testing, servicing and troubleshooting of this product, it may be necessary to work with live electrical components. Have a qualified licensed electrician or other individual who has been properly trained in handling live electrical components perform these tasks. Failure to follow all electrical safety precautions when exposed to live electrical components could result in death or serious injury.

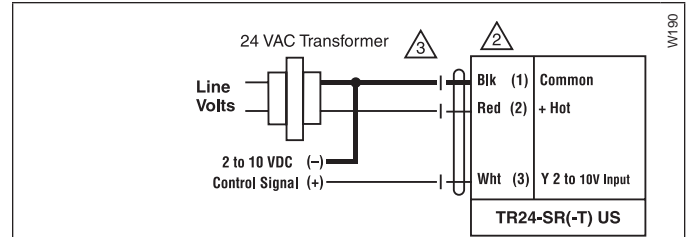

2 to 10 VDC Control of TR24-SR(-T) US

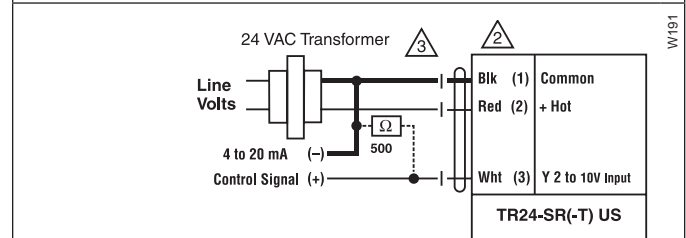

4 to 20 mA Control of TR24-SR(-T) US

Direct/Reverse acting switch is under wiring cover.
 R = CW with decrease in signal
 L = CCW with decrease in signal
 No feedback