

## T25 Two-Stage Room Thermostat

### Application Requirements

T25 thermostats are for line- or low-voltage service requiring accurate control of two operating functions. There are two stages of control for heating and cooling with automatic changeover on three- and four-pipe fan coil installations and similar applications. Typical uses are for compressor controls, relays, valves, fan coils, and other applications where low differentials and accurate sensing are required.

### Installation

**IMPORTANT:** The T25 Series Thermostats are intended to control equipment under normal operating conditions. Where failure or malfunction of the T25 Thermostats could lead to an abnormal operating condition that could cause personal injury or damage to the equipment or other property, other devices (limit or safety controls) or systems (alarm or supervisory systems) intended to warn of, or protect against, failure or malfunction of the T25 Thermostats must be incorporated into and maintained as part of the control system.

### Parts Included

- 1 thermostat
- 1 Allen wrench
- 2 machine screws

### Dimensions

Refer to Figure 1 for detailed dimensions of the T25 Two-Stage room Thermostat.

### Mounting

#### Location Considerations

Mount the thermostat about 4 to 5 ft. (1.2 to 1.5 m) above the floor on an interior wall, where it can sense the average room temperature. It is designed for vertical mounting and will produce the lowest operating differentials when installed in this position.

Do not mount the thermostat where it may react to heat or cold from water pipes, windows, doors, lamps, sunlight, or other heat or cold sources.

On unit heater applications, place the thermostat below and behind the heater in the path of air entering the unit, not in the path of discharge air.

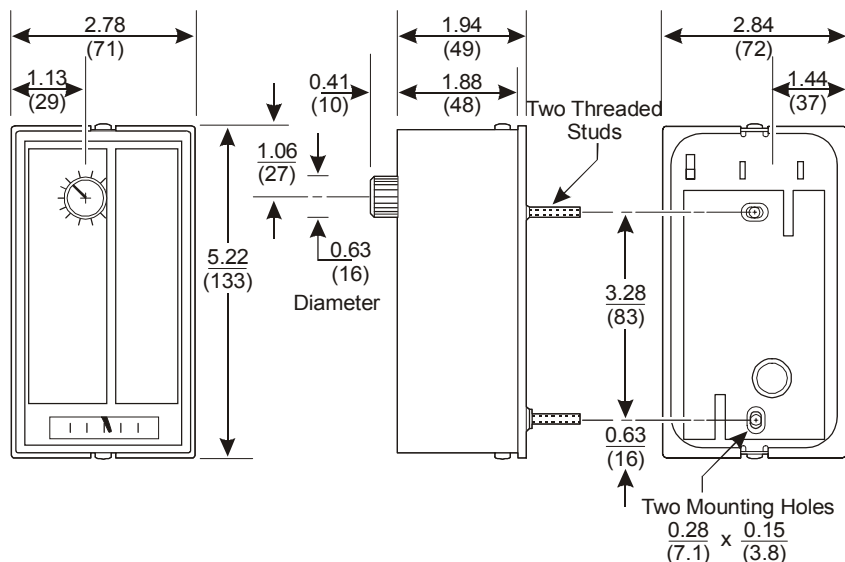
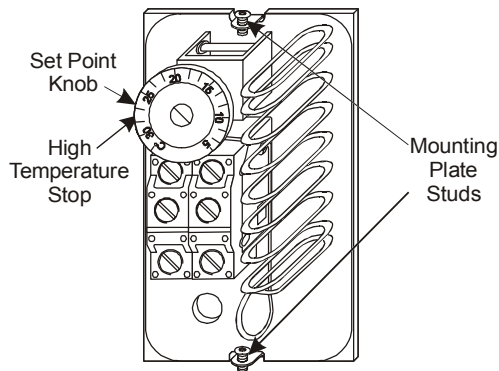


Figure 1: T25A Dimensions, in. (mm)



**Figure 2: Inside View of T25**

### Wall Box Mounting

To mount the thermostat to an electrical conduit box, proceed as follows:

1. Remove the external adjustment knob, when furnished, by loosening the knob set screw using the provided Allen wrench. Slide the knob from the adjustment shaft.
2. Remove the cover by loosening the Allen-head screws at the top and bottom of the thermostat.
3. Remove the adaptor plate from the back of the thermostat by loosening the machine nuts (inside the thermostat) from the two threaded studs on the plate.



**WARNING: Risk of Electrical Shock.**

Electrical thermostat wires may be energized at line-voltage potential. Disconnect the electrical power supply before pulling wires to avoid possible electrical shock or equipment damage. More than one disconnect may be required to de-energize control.

4. Pull the electrical thermostat wires through the opening in the thermostat adaptor plate.
5. Secure the adaptor plate to the conduit box with the two machine screws provided.
6. Insert the wires through the opening in the thermostat base.
7. Place the thermostat on the adaptor plate, so that the two threaded studs on the adaptor plate pass through the corresponding holes in the thermostat base (upper left and lower right corners).
8. Secure the thermostat to the adaptor plate with the two machine nuts referred to in Step 3.
9. Refer to the *Wiring* section to connect the terminals on the Pennswitches.

10. If a high temperature stop is desired, proceed to the *Setup and Adjustments* section.

### Wall Surface Mounting

To mount the thermostat directly to an interior wall surface (no electrical box) proceed as follows:

1. At the desired thermostat location, make an opening in the wall approximately 1/2 in. in diameter, and pull the wires through it.
2. Plug the rest of the wall opening to prevent drafts from affecting the operation of the thermostat (when applicable).
3. Remove the adjusting knob, thermostat cover, and adaptor plate. See Steps 1, 2, and 3 under *Wall Box Mounting*.
4. Pull the electrical thermostat wires through the opening in the thermostat adaptor plate.
5. Secure the adaptor plate to the mounting surface.

**Note:** When mounting on uneven surfaces, always use the adaptor plate in order to prevent twisting the unit and consequently affecting thermostat calibration and operation.

6. Proceed as outlined in Step 6 through Step 10 in the *Wall Box Mounting* section.

### Wiring

Make all wiring connections using copper conductors only in accordance with the National Electrical Code and local regulations. Use a relay or motor starter to handle loads that exceed the rating of the thermostat.



**WARNING: Risk of Electrical Shock.**

Disconnect the electrical power supply before making the wiring connections to avoid possible electrical shock or equipment damage. On multiple circuit units, more than one circuit may have to be disconnected.

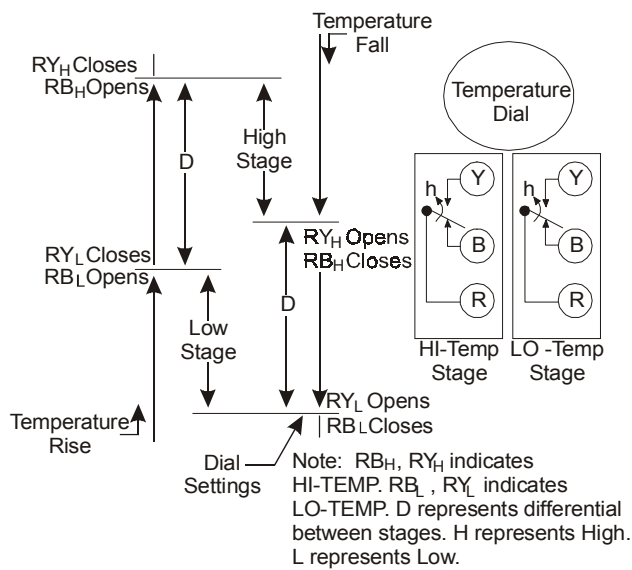
For low-voltage applications, use 18 AWG wire or larger for all connections to the thermostat. Use 14 AWG wire on runs over 500 ft. Make all splices in junction boxes using approved solderless connectors, or by soldering and then taping the connection.

Make all wiring connections to the screw terminals on the Pennswitches.

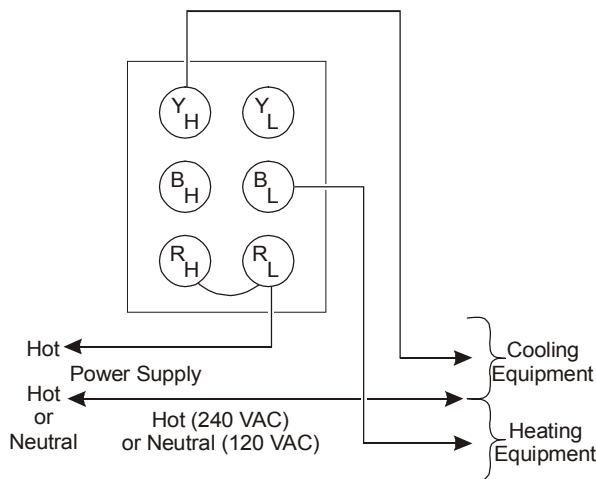
- Use the terminal screws supplied with the Pennswitches. Screws longer than 1/4 in. can cause problems in making proper connections.
- Connect the thermostat grounding provision to the grounding conductor of the branch circuit.

Refer to Figure 4, Figure 5, Figure 6, Figure 7, and Figure 8 for typical wiring diagrams.

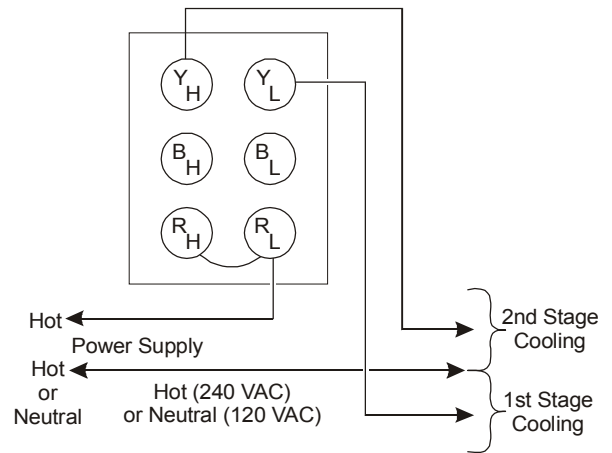
Note: Use the furnished terminal screws (8-32 by 1/4 in. binder head). Substitution of other screws may cause problems in making proper connections.



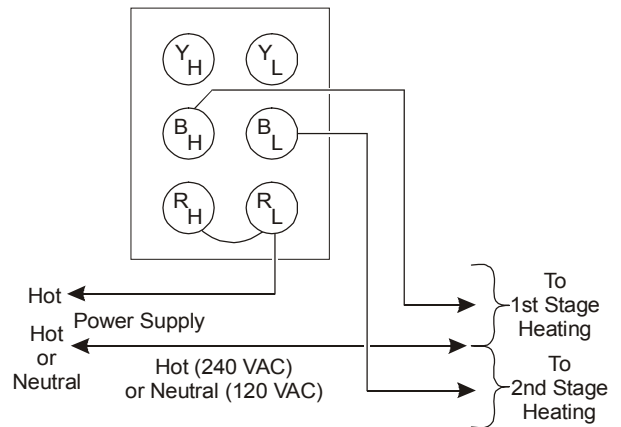
**Figure 3: Two-stage Control Switching Action**



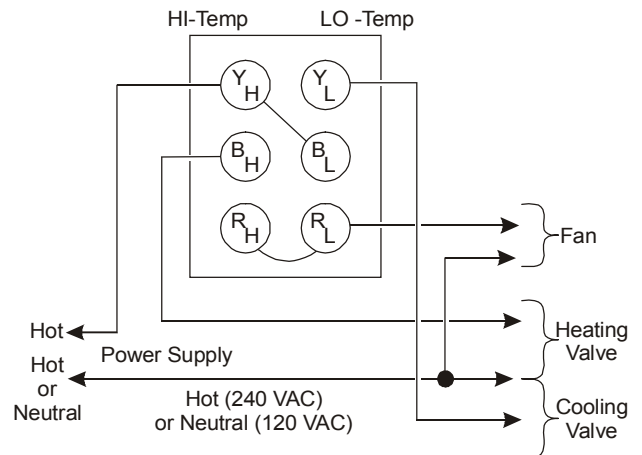
**Figure 4: Typical Wiring for One-stage Heating and One-stage Cooling**



**Figure 5: Typical Wiring for Two-stage Cooling**

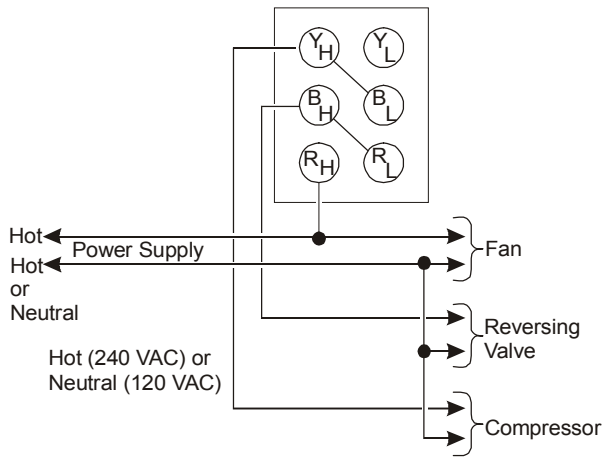


**Figure 6: Typical Wiring for Two-stage Heating**



Note: The application is wired for simultaneous cycling of valve and fan. Cooling will operate at a higher temperature than heating even though connections are to opposite stages.

**Figure 7: Typical Wiring for Fully Automatic Heating and Cooling Service**



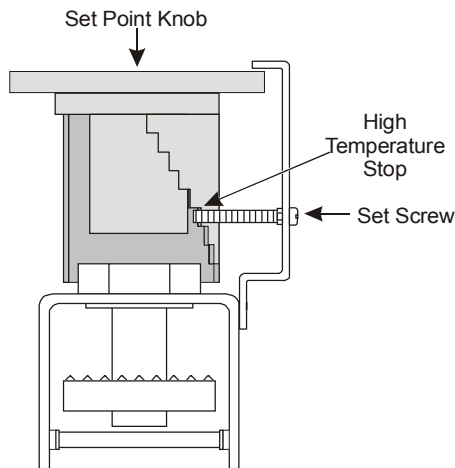
**Figure 8: Typical Heat Pump Wiring for Combination Heating and Cooling, Continuous Fan**

## Setup and Adjustments

The indicator line on models with knobs denotes the thermostat dial setting. Concealed adjustment models have internal adjustment dials. Adjust concealed dial models (with the cover removed) by turning the dial and lining up the desired dial setting at a 9 o'clock position when the thermostat is vertical.

## Calibration

The T25 thermostats are factory calibrated. Do not attempt field calibration.



**Figure 9: Setting the High Temperature Stop**

## Commissioning the High Temperature Stop

If a high temperature stop is desired, refer to Figure 9 and follow the procedure described below.

1. Turn the thermostat dial so that the desired setting, minus one degree, is in line with the slot in the high temperature slot bracket, as shown in Figure 9. For example, to set the stop at 76°F (24°C), line up the 75°F (23°C) mark on the temperature dial with the slot.
2. Loosen the stop screw and slide the screw toward the back of the dial (the front of the unit) against the step behind the dial.
3. Tighten the stop screw.

Note: For concealed adjustment models, set the desired temperature and switch functions before replacing the cover.

## Checkout

Before completing the installation, observe at least three complete operating cycles to ensure that all components are functioning correctly.

## Heating

If the unit has a system selector, select the Heating or Auto position. Turn the set point knob to a temperature well above room temperature. This simulates a temperature fall and should cycle on the heating system. Turn the set point knob about 10°F (5.6°C) below the room temperature. The heating system should stop. Turn the knob to the desired setting.

## Cooling

If the unit has a system selector, select the Cooling or Auto position. Turn the set point knob to a temperature well below the room temperature. This simulates a temperature rise and should cycle on the cooling system. Turn the set point knob about 10°F (5.6°C) above the room temperature. The cooling system should stop. Turn the knob to the desired setting.

## Repairs and Replacement

Do not make field repairs. To replace the thermostat, cover, knobs, or faceplate contact the nearest Johnson Controls representative.

**Table 1: Electrical Ratings**

Motor Ratings	120 V	208 V	240 V	277 V
AC Full Load Amperes	6.0	3.5	3.0	-
AC Locked Rotor Amperes	36.0	21.0	18.0	-
Non-inductive Amperes	10.0	9.2	8.0	7.2
Pilot Duty—125 VA 24 to 277 VAC				

Note: When used as a two-circuit switch, the total connected load must not exceed 2,000 VA.

**Technical Data**

<b>Product</b>	T25 Two-Stage Room Thermostat	
<b>Output</b>	Single Pole, Double Throw (SPDT)	
<b>Switches</b>	Two Enclosed Pennswitches	
<b>Cover</b>	Cold Rolled Steel with “Tawny Silver” Finish	
<b>Differential (Mechanical)</b>	<b>Each Stage</b>	0.7F° (0.4C°) Approximately
	<b>Between Stages</b>	3F° (1.7C°) Non-Adjustable
<b>Supply Voltage</b>	24 V, 120 V, 208 V, 240 V, 277 V	
<b>Mounting</b>	With Adaptor Plate for Wall or Electrical Box Mounting; Vertical Mounting Only	
<b>Range</b>	<b>Thermostat</b>	40 to 90°F (5 to 32°C)
	<b>Thermometer</b>	50 to 90°F (10 to 32°C)
<b>Sensing Element</b>	Liquid Charged, No Leveling Required	
<b>Shipping Weight</b>	<b>Individual Pack</b>	1.5 lbs (0.7 kg)
	<b>Overpack of 20 Units</b>	32 lbs (14.5 kg)
<b>Terminals</b>	Screw Type. Color Coded: Red is Common. Red Closes to Yellow on Temperature Rise. Red Closes to Blue on Temperature Drop.	
<b>Thermometer</b>	Bimetal	
<b>Agency Listings</b>	UL Listed; File E6688, CCN XAPX (U.S.), CCN XAPX7 (Canada) CSA Certified; File LR948, Class 4813 02	

*The performance specifications are nominal and conform to acceptable industry standards. For application at conditions beyond these specifications, consult the local Johnson Controls office. Johnson Controls, Inc. shall not be liable for damages resulting from misapplication or misuse of its products.*



**Controls Group**  
507 E. Michigan Street  
P.O. Box 423  
Milwaukee, WI 53201

Printed in U.S.A.  
www.johnsoncontrols.com