



# Thermoplastic Valves & Accessories



## PRODUCT GUIDE & ENGINEERING SPECIFICATIONS



**Contact Spears® for any information not found.**



The information contained in this publication is based on current information and Product design at the time of publication and is subject to change without notification. Our ongoing commitment to product improvement may result in some variation. No representations, guarantees or warranties of any kind are made as to its accuracy, suitability for particular applications or results to be obtained therefrom. For verification of technical data or additional information not contained herein, please contact Spears® Technical Services Department [West Coast: (818) 364-1611 — East Coast: (678) 985-1263].

Since 1969, Spears® Manufacturing Company has developed high quality thermoplastic piping system components to better meet industry needs. Spears® thermoplastic valves have been developed through years of product improvement testing, combined with the latest in computer aided engineering and manufacturing technology. Today, Spears® valves are recognized for their quality, reliability and long service life. Backed by the best in customer service and product availability, Spears® valves are the first choice for use in a wide variety of applications, including Industrial & Chemical Processing, Turf & Irrigation, Pool & Spa, and numerous Original Equipment Manufacture products.

## Valve Function Basics

### Ball Valves

Ball valves derive their name from the on/off function accomplished by means of a flow-controlling ball located in the center of the valve body. A hole through the center of the ball (valve bore) connects the inlet and outlet sides of the valve for fluid stream transfer. The ball rotates 90° on an axis perpendicular to the fluid stream in order to block flow in the “off” position. The ball is held in place between two valve seats, which serve as a “bubble tight” seal off, while providing lubrication during valve operation. Elastomer O-rings are used in the stem and seal carrier to prevent fluid leakage. Pressure drop is virtually eliminated in the full-open position, since the valve bore is the same size as Schedule 80 system piping. The T-Style ball valve is a special configuration incorporating a Tee fitting at one end of the valve. This design maintains close proximity of the valve to the fluid mainline to minimize “dead leg” of potential fluid accumulation, where required by specific application.

### 3-Way Ball Valves

3-Way ball valves are “diverter” style ball valves that provide an additional port to redirect the fluid stream. Valve configurations are either vertical (bottom branch port) or horizontal (side branch port). Multiple ball-port options are available in which different hole patterns in the valve ball provide alternative paths to divert flow. These diverter style 3-Way ball valves have no shutoff on the branch ports.



### Check Valves

Check valves are automatic valves that open with forward flow and close with reverse flow. Exact operation will vary depending on the type of check valve mechanism. These include a ball (Ball Check), a swinging disc (Swing Check), a “double disc” (Butterfly Check), a weighted plug (Y-Check), and spring assisted types of check devices. These include a spring assisted swinging disc (Spring Check) and a spring mounted linear disc (In-Line Spring Check). Regardless of type, a check valve has a closure device positioned in the valve body between inlet and outlet so that the fluid stream is easily transmitted in the direction of flow, but is allowed to move against the check device in the event of flow in the reverse direction. Reversed flow is stopped or held in “check” by fluid backflow pressure which seats the closure device against the valve body. Standard elastomer O-ring seals are used in all Spears® Ball Check Valves and Industrial Swing Check Valves. Utility Swing and Spring Check Valves, and Butterfly Check Valves use an elastomer membrane seal; In-Line Spring Check Valves and Y-Check valves use an elastomer seat. Spears® Check Valves have been carefully engineered to minimize pressure drop and can be installed in either horizontal or vertical positions, within the limitations of the specific type of closure device. Ball Check Valves are well suited for general applications of fluids free from debris and entrained solids. Butterfly Check Valves have minimum space requirements and, along with Swing Check Valves, are better for use with fluids containing solids or debris. Swing Check Valves additionally allow higher volume of fluid transmission. Industrial Swing Check models can be fitted with an optional counter balance device to further control closing speed. The Utility Spring Check Valve (spring assisted Swing Check) aids in valve closing, while the In-Line Spring Check can be adjusted for resistance to opening pressure.



### Swing Check Ball Valves

Swing check ball valves are a special design that combines the basic function of a ball valve and a swing check valve for use in general purpose applications where an in-line ball and check valve configuration is required.

### Gate Valves

Gate valves perform an on/off function accomplished by means of a flow-controlling gate centered in the valve body between the inlet and outlet sides of the valve. The gate moves along a vertical stem axis, perpendicular to the fluid stream, thereby blocking the flow in the closed position and variably increasing the flow as the gate is moved to the full open position. Spears® gate valves use either a cylindrical plug (Plug Gate Valves) or a wedge-shaped gate and sealing surface design (regular Gate Valves). Both provide positive shut off when engaged with the valve body in the closed position and feature non-rising type stem. This provides vertical movement of the gate without extension of the stem above the valve body.

### Butterfly Valves

Butterfly valves are rotary valves in which a disc is rotated 90° to open or close the flow passage. In the full closed position, the disc seals against an elastomer seat. Flow control can be accomplished by varying the degree to which the disc is opened. Spears® Standard and True Lug type Butterfly Valves utilize a special offset disc and low contact seat designed. Spears® Wafer style Butterfly Valve incorporates a special low contact, disc-mounted seat and centered disc. These designs minimize operation torque and improve sealing capabilities over conventional rubber seated valves.

### Diaphragm Valves

Diaphragm valves utilize a moveable elastomeric membrane, or “diaphragm”, to constrict the flow passage through the valve, thereby controlling or throttling fluid flow. The diaphragm additionally isolates system fluids from internal moving parts of the valve. In the Weir-Type design, a raised area in the center of the waterway serves as a seal-off point for the elastomeric diaphragm. When installed in a horizontal position, this additionally facilitates drainage of fluid from the valve. From the full-open position, operation of the valve is accomplished by rotating the handle to vertically move a compressor unit on a threaded shaft. This compresses the attached elastomeric diaphragm to constrict the waterway and finally seal-off flow. Spears® diaphragm valves provide an indicator in the center of the handle for 360° visibility of valve position, and a special stop on the compressor to prevent damage from over-tightening. The T-Style “Zero Dead-Leg” Diaphragm Valve is a special configuration incorporating a Tee fitting at one end of the valve. This design maintains close proximity of the valve to the fluid mainline to minimize “dead leg” of potential fluid accumulation, where required by specific application.

### Globe Valves & Y-Pattern Valves

Globe valves are characterized by a partition separating the two halves of the body with a center passage that is opened and closed by a screw-down/screw-up seat mounted at right angle to the body. The “Globe” name was derived from the original spherical body design for these valves. Globe valves offer excellent flow regulating characteristics, but have a high resistance due to the turning flow path. The Y-Pattern Valve (aka, “oblique valves”) is a hybrid globe valve incorporating an angled stem. This less restrictive flow path design improves flow while maintaining the same excellent throttling characteristics as a globe valve.

### Needle Valves

Needle valves are small sizes of globe valves fitted with a tapered plug. The tapered plug or “needle” is screwed in or out of a mating orifice in the body and thus controls the effective orifice size. Needle valves are excellent for metering and other fine adjustment flow control applications. Spears® Needle Valves use PTFE stem seals and no elastomers for optimum chemical resistance. These are produced in both a conventional “globe” pattern and convenient right-angle pattern design for application versatility.





## ISO 9001 Certified Design & Manufacturing Quality Program

Spears® Quality Management System is certified to the strict requirements of ISO 9001 for optimum control of product design, development, and production. Quality improvement and customer satisfaction are central to each stage of producing Spears® valves from conception through final delivery.

## Development & Testing

The foundation of Spears® products is development, testing, and more testing. Spears® valve development combines proven experience with structural testing at the design level. Materials and design are correlated in computer engineering stress analysis to yield the optimum structure and function of each valve component. Resulting products are then subjected to numerous tests for performance validation of dimensional stability, sealing capability, hydrostatic burst pressure, operational torque, flow capacity, vacuum application suitability and cyclic pressure analysis. Once approved, production valves and components are routinely subjected to dimensional, functional and burst pressure verification tests.

### 100% Sealing Capability Verification

All Spears® ball valves are air-tested for 100% verification of positive sealing during the manufacturing process.

### Hydrostatic Burst Pressure Verification

Representative valve samples are routinely subjected to an internal hydrostatic pressure of 3.2 times their designated pressure rating in a 60-70 second test per ASTM D 1599 during each production run.

### Vacuum Service

Validation of Spears® valves rated for vacuum service is determined from 1-hour tests at 26 in. Hg vacuum with less than 1 in. Hg loss. A vacuum lubricant should be applied to elastomer-seated valve seats, such as Spears® Butterfly Valve or True Union Ball Check Valve, to prevent the seat from drying out in vacuum service applications.

## Spears® Valve Innovations

Not all plastic valves are the same. Spears® valves incorporate several unique features not found in competitive products. The following are a few examples of Spears® innovative improvements to conventional valve designs.

### Spears® Safe-T-Shear® Stem

This important SAFETY FEATURE was developed to help prevent line fluids from leaking out in the event of ball valve stem damage. Engineered for high strength, the stem incorporates a special shear point to control accidental breakage. Over-torquing breaks occur above the stem O-ring leaving the seal intact until repair or replacement can be made.

### Spears® Heavy Buttress Thread Components

When it comes to handling the hydraulic force of high internal pressures, the brute strength of the buttress thread is clearly the best. Its broad bearing surface with an angular backing provides greater thrust support than conventional square-cut, ACME-type threads commonly used in similar ball valve components. All Spears® Ball Valve union nuts and seal carriers are designed with buttress threads for greater strength and pressure handling capabilities — one of the strongest in the plastic valve industry!

### Low Torque, Low Wear Butterfly Valve Seats

Spears® Butterfly Valves provide the lowest operating torque available. Sealing contact between disc and seat takes place only at the close of the valve, allowing free travel through the full range of opening. This unique design eliminates seat creep, extrusion and wear typical with conventional liner-type seats. Exclusive design interlocks seat and body to prevent washout or blowout.

### Flow Balanced Ball Check Valves

Improper ball check valve design can significantly restrict flow, create ball-chatter and even result in reverse ball travel and open flow shutoff! As a result of extensive design testing, Spears® has engineered the internal flow characteristics of the True Union Ball Check Valve to optimize fluid transmission and virtually eliminate ball-chatter.

### Special Reinforced (SR) Female Plastic Threads

This patented Special Reinforced (SR) design is one of the most significant improvements in female plastic thread reliability. Not just an added reinforcing ring, this unique pre-compression design compensates for expansion forces generated from normal tapered pipe thread joint make-up. Radial stress is neutralized in normal installations and contained in severe over tightening situations. Spears® SR Threads are available on a variety of Spears® industrial valves using SS316 reinforcement for optimum chemical and corrosion resistance. Spears® SR Female Spigot Adapters are also available for quick conversion of any slip-socket style valve end connector.





## Spears® Thermoplastic Piping System Materials

### Benefits of Spears® Thermoplastic System Materials

Unlike metal, plastics never rust, scale, or pit — they virtually last forever. Thermoplastics are abrasion resistant, chemical and corrosion resistant, nonconductive, lightweight, and operate at lower friction-loss levels than metals. Moreover, plastics are nontoxic and environmentally safe. Adding these benefits with ease of installation at substantially lower costs, thermoplastic piping system components are the proven choice for years of maintenance free system operations.

### Joining Methods for Spears® Thermoplastic Systems

Spears® thermoplastic piping system products are designed around primary components manufactured from PVC, CPVC or PP materials and their glass filled varieties. PVC and CPVC materials can be easily joined by solvent cement welding plus threaded, flanged or mechanical coupled connections. Spears® PP products are joined by using flanged or threaded connections featuring Spears® patented Special Reinforced (SR) female plastic threads.

### Material Considerations in Application and System Design

PVC, CPVC and PP thermoplastic piping system components will give years of trouble free service with proper attention to application and system design. To avoid problems, the following key points must be considered when selecting materials for an application and in designing a system for their use.

- 1. Fluid incompatibility** of certain chemicals, especially petroleum distillates and derivatives, can cause environmental stress cracking in different thermoplastic compounds. Chemical compatibility of all valve or system components, including solvent cements, must be verified before installation. Verification of fluid compatibility is at the discretion of the user.
- 2. Temperature-pressure relationships** must be considered. Product pressure ratings are based on use of water mediums at 73°F. In general, product pressure ratings must be de-rated as temperature increases (see Temperature Pressure Table for individual valves).
- 3. Expansion and contraction** is greater in thermoplastic systems than in metal systems. As a result, system design must be flexible to allow for movement. Use of Spears® Thermoplastic Expansion Joints is recommended.
- 4. Extreme heat or cold** where internal fluids may freeze or where temperatures may exceed thermoplastic design limits must be avoided, including consideration of storage locations.

- 5. Direct sun exposure** results in high thermal heat absorption, especially in darker color thermoplastic materials. A white water-based exterior latex paint can be applied to reduce heat buildup.
- 6. Lower impact resistance** of thermoplastic system components than that of metal systems requires avoidance of sharp, pointed objects in both above and below ground installations, including mounting devices and backfilling operations.
- 7. Proper installation** is essential. Special attention must be given to technique and instructions for making solvent cemented connections, threaded connections, flanged connections, and for installation of valves and other individual system components. System design must also take into account support, thrust blocking, transition to different materials and other installation related factors.
- 8. Threaded joints** require several considerations. First, pressure capacities of threaded system components should be de-rated to 50% of the rating for corresponding type and size of thermoplastic pipe. **NOTE:** Valves have individual pressure ratings and do not require de-rating for threaded connections. Second, as with internal fluids, certain paste sealants may cause environmental stress cracking in thermoplastic materials, and compatibility should be verified before use. Finally, the leading cause of thread joint failures is from over tightening female thermoplastic threads. Use of Spears® Special Reinforced (SR) Threads is recommended.
- 9. Hydraulic Shock** (water hammer; surge pressure) in thermoplastic piping systems can burst pipe, fittings, and valves. Anticipated surge pressures should be calculated and included in maximum internal pressure ratings of system components (specified “Non-Shock” pressure rating for valves). Safeguards should be incorporated in system design to vent pressures and eliminate entrapped air. Fluid velocities should not exceed a maximum of 5 feet per second in thermoplastic systems.
- 10. Non-liquid transport** — **WARNING:** Spears® Manufacturing Company **DOES NOT RECOMMEND** the use of thermoplastic piping products for systems to distribute or store compressed air or gases. The use of Spears® products in compressed air or gas systems automatically voids Spears® warranty for such products, and their use against our recommendation is entirely the responsibility and liability of the installer. Spears® Manufacturing Company will not accept responsibility for damage or impairment from its products, or other consequential or incidental damages caused by misapplication, incorrect assembly, and/or exposure to harmful substances or conditions.





## Individual Materials Overview Thermoplastics

### PVC — Poly Vinyl Chloride

PVC is one of the most specified thermoplastics for piping system components, including, valves, fittings, flanges, and many specialty products. PVC has excellent chemical and corrosion resistance to a broad range of fluids including water, deionized water, most mineral acids, bases, salts and paraffinic hydrocarbon solutions. PVC is not recommended for use with chlorinated or aromatic hydrocarbons, esters, or polar solvents such as ketones. Spears® PVC materials conform to ASTM Cell Classification 12454 (formerly designated as Type I, Grade 1). The maximum recommended service temperature of PVC products is 140°F (60°C).

### Glass Reinforced PVC — Fiberloc®

Fiberloc® is a registered trademark of PolyOne Corporation. Fiberloc® is a glass fiber reinforced PVC composite material. While maintaining the traditional properties of PVC, Fiberloc® increases its strength, stiffness, and dimensional stability from glass fiber reinforcement. The maximum recommended service temperature of Fiberloc® products is 140°F (60°C).

### CPVC — Chlorinated Poly Vinyl Chloride

Chlorinated PVC is used for higher temperature applications than PVC, especially for handling hot corrosive liquids. With similar chemical and corrosion resistance to PVC, increased chlorine content gives CPVC superior thermal resistance. CPVC is not recommended for use with chlorinated or aromatic hydrocarbons, esters, or polar solvents such as ketones. Spears® CPVC materials conform to ASTM Cell Classification 23447 (formerly designated as Type IV, Grade 1). The maximum recommended service temperature of CPVC products is 200°F (93°C).

### Glass Reinforced CPVC

This special composite compound has the basic properties of CPVC with additional strength, stiffness, and dimensional stability from glass fiber reinforcement. The maximum recommended service temperature of glass reinforced CPVC products is 200°F (93°C).

### PP — Polypropylene

Polypropylene is used in a variety of Spears® valves where different chemical resistance and lower temperature impact resistance is required as compared to PVC or CPVC. The excellent impact resistance characteristics of polypropylene make this polymer the choice for Spears® valve handles. Spears® PP products carry a maximum recommended service temperature of 180°F (82°C).

### Glass Reinforced PP

Glass reinforced polypropylene is used in numerous valves and valve accessories where additional strength or stiffness is required over standard PP materials while maintaining basically the same range of chemical resistance.

### PTFE/PFA — Polytetrafluoroethylene/ Perfluoroalkoxy Resin

PTFE is a ram extrusion process while PFA is a melt processed fluoroplastic. These fluoroplastics are virtually inert to most chemicals, acids bases and solvents. Due to their low coefficient of friction, these materials are considered “self-lubricating” making them an excellent choice for valve seats, bearings and thrust washers. Spears® proprietary processing of PTFE with other materials allows low friction characteristics to be built into a variety of thermoplastic components used in Spears® valves. Fluoroplastics are serviceable to 500°F (260°C).

### PTFE/HDPE

Spears® proprietary composition of PTFE and High Density Polyethylene is used in a variety of valve seats, bearing washers, and other valve components requiring durability and improved lubricity. The chemical resistance of HDPE is somewhat higher than that of LDPE and generally exceeds that of PVC and CPVC. HDPE has excellent resistance to acids, alcohols and bases. In comparison to PVC and CPVC, HDPE is somewhat less resistant to aliphatic hydrocarbons and has more limited resistance to oxidizing agents. HDPE is serviceable to 230°F (110°C).

### Low Extractable PVC

Low Extractable PVC material developed for use in UPW (Ultra Pure Water) and other high purity applications. Independently tested, Low Extractable PVC provides superior resistance to regular PVC for leaching of anion, cation, and numerous trace metals when subjected to 18.2 megohm deionized water while maintaining ease of installation. Low Extractable PVC has the same basic chemical resistance as regular PVC.

### Elastomers

#### EPR (EPDM) — Ethylene propylene rubber

Used in O-ring seals, EPR is recommended for water, chlorinated water, dilute acids and alkalines, alcohols, and has excellent resistance to ozone. EPR is not recommended for petroleum oils, di-ester lubricants, strong acids, or strong alkalines. The maximum recommended service temperature of EPR is 300°F (149°C).





### FKM — Fluoroelastomer

Fluoroelastomers are a special purpose fluorocarbon-based synthetic rubber categorized under the ASTM designation of “FKM”. The FKM O-ring is commonly referred to as a “Viton® O-ring”. However, “Viton®” is only one of many FKM brand names and is a registered trademark of DuPont. Performance Elastomers L.L.C. Spears® uses general purpose Type 1 FKM O-rings with a minimum of 66% fluorine content for the best balance of overall properties. FKM exhibits a very broad range of chemical resistance, including petroleum oils, di-ester based lubricants, silicate fluids and greases, halogenated hydrocarbons, and mineral acids. FKM is not recommended for ketones, amines, anhydrous ammonia, hot hydrofluoric or chlorosulfonic acids, or automotive brake fluids. The maximum recommended service temperature of FKM is 400°F (204°C).

### Nitrile (Buna-N) — Nitrile elastomer

Used in O-ring seals, nitrile elastomers are recommended for petroleum oils and fluids, silicone oils and greases, di-ester based lubricants, ethylene glycol based fluids, and cold water. Nitrile is not recommended for phosphate ester hydraulic fluids, halogenated hydrocarbons, strong acids, ketones, ozone or automotive brake fluids. The maximum recommended service temperature of nitrile is 275°F (135°C).

### FFKM (Aegis™, Kalrez®) — Perfluoroelastomer

Aegis™ is a trademark of ISC Freudenberg-NOK, Kalrez® is a registered trademark of DuPont-Dow Elastomers. These specialty materials are virtually inert and provide the greatest range of chemical resistance found in an elastomer. However, be aware that perfluoroelastomers are substantially more expensive than other elastomer compounds. Perfluoroelastomers are serviceable to 600°F (360°C) and performance is limited at very low temperatures.

### CSM (Hypalon®) — Chlorosulfonated Polyethylene

Hypalon® is a registered trademark of DuPont-Dow Elastomers. CSM is a close match to neoprene, but it has improved chemical resistance. This specialty compound offers good abrasion resistance with superior resistance to weather, ozone, sunlight and oxidation. CSM has excellent resistance to alcohols, alkalis and acids, very good color stability with moderate resistance to oils and gasoline. CSM is not recommended for use with aromatic solvents. CSM has limited flexibility at low temperatures and relatively poor compression set. As a result, CSM is not generally manufactured as O-rings. CSM is serviceable to 300°F (149°C). Hypalon® is offered as an alternative diaphragm elastomer in Spears® Diaphragm Valves.

### PFA/FEP Encapsulated O-rings

O-ring encapsulation places a PFA or FEP material around a FKM elastomer core to provide very high chemical resistance. However, this is not without a trade-off. The PFA/FEP encapsulation is far less resilient than an elastomer and may not perform as well in certain O-ring applications. PFA/FEP encapsulated O-rings should be used only where an elastomer O-ring cannot meet requirements.

### Elastomer Backed PTFE

Used in Spears® PTFE Diaphragm Valves, this chemically bonded laminate provides the chemical resistance of PTFE with improved resilience from a thick elastomer backing for greater sealing capability than solid PTFE Diaphragms. Use of heavier, high grade EPDM or FKM backing materials eliminates the need for “gas barrier” PTFE Diaphragm designs.

### Metals

#### Zinc Plated Steel

Zinc plated carbon steel is the standard for general purpose bolts, nuts and fasteners. Zinc plated steel provides good corrosion resistance for most dry environment applications and normal operating conditions.

#### Stainless Steel

Stainless Steel provides superior corrosion resistance than natural or plated carbon steels. Common grade is 18-8, which is excellent for general purpose use in nuts, bolts and fasteners. SS302 and SS304 are commonly used in a variety of sheet stock or deep drawn metal components. SS316 is the preferred choice for harsh chemical and corrosion environments and is used in the majority of Spears® industrial valves and accessories where stainless steel is required.

#### PTFE Coated Stainless Steel

Where very high chemical resistance is needed, Spears® offers a special PTFE coated, stainless steel Butterfly Valve stem. This tough, chemically bonded coating makes the stem virtually inert to most chemicals without loss of function or reliability.

#### Special Alloys (Titanium, Hastelloy®, Alloy 20, etc.)

A variety of specialty metals can be obtained on a custom order basis for use in Spears® products where specific chemical or corrosion resistance is required and specified by user. Please note that custom components generally require extended lead-time and may have significant costs.





## Thermoplastic Valves Product Guide & Engineering Specifications

### Materials

### Temperature Pressure De-rating for PVC, CPVC & PP Thermoplastic Materials

Elevated temperature fluid mediums require a de-rating of thermoplastic pipe maximum internal pressure ratings at 73°F. To determine the maximum internal pressure rating at an elevated temperature, simply multiply the pipe pressure rating at 73°F by the percentage specified for the desired temperature.

**PLEASE NOTE** — Valves have different elevated temperature ratings than pipe & fittings. See individual valve recommendations.

System Operating Temperature °F (°C)	73 (23)	80 (27)	90 (32)	100 (38)	110 (43)	120 (49)	130 (54)	140 (60)	150 (66)	160 (71)	170 (77)	180 (82)	190 (88)	200 (93)	210 (99)
<b>PVC</b>	100%	90%	75%	62%	50%	40%	30%	22%	-0-	-0-	-0-	-0-	-0-	-0-	-0-
<b>CPVC</b>	100%	100%	91%	82%	73%	65%	57%	50%	45%	40%	32%	25%	22%	20%	-0-
<b>PP</b>	100%	90%	75%	70%	65%	50%	42%	36%	30%	25%	20%	15%	-0-	-0-	-0-

### Typical Physical Properties of PVC, CPVC & PP Thermoplastic Materials

The following table lists typical physical properties of PVC, CPVC and PP thermoplastic materials. Variations may exist depending on specific compound and product.

Properties	ASTM Test Method	PVC	CPVC	PP Natural*
<b>Mechanical Properties, 73°F</b>				
Specific Gravity	D 792	1.41	1.55	.907
Tensile Strength, psi	D 638	7,200	8,000	5,240
Modulus of Elasticity, psi	D 638	440,000	360,000	231,000
Compressive Strength, psi	D 695	9,000	10,100	---
Flexural Strength, psi	D 790	13,200	15,100	---
Izod Impact, notched, ft-lb/in	D 256	.65	1.50	3.02
<b>Thermal Properties</b>				
Heat Deflection Temperature, °F				
at 66 psi	D 648	165	217	201
Thermal Conductivity, BTU/hr/sq ft/°F/in	C 177	1.02	.95	
Coefficient of Linear Expansion, in/in/°F	D 696	3.1 x 10 <sup>-5</sup>	3.4 x 10 <sup>-5</sup>	5.42 x 10 <sup>-5</sup>
<b>Flammability</b>				
Limiting Oxygen Index, %	D 2863	43	60	
UL 94 Rating		94V-0	V-0, 5VB, 5VA	HB
<b>Other Properties</b>				
Water Absorption, % 24 hr.	D 570	.05	.03	.02
Industry Standard Color		Dark Gray / White	Medium Gray	Natural/Beige
Minimum ASTM Cell Classification	D 1784/D 4101	12454	23447	PP0112 B65242
NSF® Potable Water Approved		Yes	Yes	Yes

\* Glass filled PP will have slightly different values with higher tensile strength.



## Spears® Valve Standards

Standards provide greater assurance of product performance and consistency, and are available to assist design engineers in system specification. The most frequently referenced industry standards for plastic piping systems are ASTM Standard Specifications and Practices. Along with ASTM Standards, additional product specifications and certifications form the basis of product conformance to which Spears® valves are manufactured.

## Individual Standards Overview

### ASTM — American Society for Testing and Materials

#### ASTM D 1784

Specifies compound physical requirements for PVC and CPVC materials used in the manufacture of thermoplastic valves, pipe, and fittings. The standard classifies compounds on the basis of several physical and chemical properties. Conformance to a particular material classification requires meeting the minimum requirements specified.

#### ASTM D 1785 and F 441

Specifies physical dimensions, test requirements, and maximum operating pressures, for Schedule 40, 80 and 120 PVC (D 1785) and CPVC (F 441) pressure pipe.

#### ASTM D 2466 and F 438

Specifies physical dimensions, test requirements, and workmanship for Schedule 40 PVC (D 2466) and CPVC (F 438) pressure fittings.

#### ASTM D 2464 and F 437

These standards have been incorporated into ASTM D 2467 and F 439, respectively.

#### ASTM D 2467 and F 439

Specifies physical dimensions, test requirements, and workmanship for Schedule 80 PVC (D 2467) and CPVC (F 439) pressure fittings.

#### ASTM D 2564, F 493, and F 656

Specifies requirements for PVC (D 2564) and CPVC (F 493) solvent cement, including component compounds, minimum resin content, viscosity, and physical performance. Standard F 656 specifies requirements for primers to be used with PVC solvent cements.

#### ASTM D 2846

Specifies physical dimensions, test requirements, and workmanship for CPVC Hot-and-Cold Water Distribution Systems, commonly referred to as CTS (Copper Tube Size).

#### ASTM D 2855

Specifies standard practice and procedures for making PVC pipe and fitting joints with solvent cement.

#### ASTM D 4101

Specifies classification of injection molding and extrusion grades of Polypropylene (PP) materials according to physical characteristics. Conformance to a particular material classification requires meeting the minimum requirements specified.

#### ASTM F 1498

Specifies dimensions and gauging of tapered pipe threads on plastic pipe and fittings.

#### ASTM F 1970

Specifies performance criteria testing, and end connection dimensions for products such as ball valves and check valves.

### ANSI — American National Standards Institute

#### ANSI B1.20.1

Specifies basic thread form, taper, and tolerances of general purpose tapered pipe threads (metal).

#### ANSI B16.5

Specifies standard bolt hole patterns and basic dimensions for Class 150 steel pipe flanges.

### NSF® International

NSF® is a third party product approval agency which tests manufacturer's product against a variety of health and product performance standards. They are one of the most recognized agencies for issuing approval of plastic piping system products for potable water use.

#### NSF® Standard 14

Certifies product suitability for potable water use, product conformance to applicable ASTM standards, and establishes minimum requirements for manufacturer's quality control programs through routine testing and facilities inspections.

#### NSF® Standard 14 Special Engineering Appurtenance Program (S.E.)

In addition to Standard 14 general requirements, the S.E. program establishes product performance requirements where no directly applicable ASTM specifications exist. NSF® S.E. specifications are developed from a combination of applicable portions of ASTM specifications and manufacturer's design specifications as a standard for conformance verification.

#### NSF® Standard 61

Developed to establish minimum requirements for the control of potential adverse health effects from products in contact with drinking water. Certifies product suitability for use in potable water systems through toxicological testing for contaminants or impurities. NSF® Standard 61 compliance is a prerequisite to NSF® Standard 14 certification.





## Thermoplastic Valves Product Guide & Engineering Specifications

### True Union 2000 Valve Overview

#### One of the Most Versatile, Compact Valve Designs Available

Spears® True Union 2000 Ball Valves, 3-Way Ball Valves and Ball Check Valves provide maximum versatility with fully interchangeable valve cartridges. Provides for easier system design modifications and upgrades in multiphase projects, or anywhere changes in valve types are desired. Simply exchange any True Union 2000 valve in-line using existing union nuts. Also mates with Spears® new 2000 Pipe Unions. All True Union 2000 valves feature a low profile, compact design for minimal space requirements. Additionally, Spears® offers valve Retrofit Kits for easy in-line replacement of other valves and factory installed Actuation Packages.



**True Union 2000  
Industrial Ball Valve**



**True Union 2000  
Industrial Ball Check Valve**



**True Union 2000  
Standard Ball Valve**



**True Union 2000  
Industrial 3-Way Horizontal  
Diverter Ball Valve**



**True Union 2000  
Industrial 3-Way Vertical  
Ball Valve**



**True Union 2000  
Industrial Tee-Style  
Ball Valve**



### Features – PVC, CPVC

This multi-featured, space saving quarter-turn shutoff valve is designed to meet the demands of today's industrial and chemical processing applications. PVC and CPVC valves are available in IPS sizes 1/2" through 6" with socket/regular thread, SR (Special Reinforced) thread, flanged or spigot end connectors and 8" Venturied valve with socket or flanged ends. Also available in metric socket and BSP thread sizes 1/2" through 2".

### Sample Engineering Specification

All thermoplastic ball valves shall be True Union 2000 Industrial type manufactured to ASTM F 1970 and constructed from PVC Type I, ASTM D 1784 Cell Classification 12454 or CPVC Type IV, ASTM D 1784 Cell Classification 23447. All O-rings shall be EPDM or FKM. All valves shall have Safe-T-Shear® stem with double O-ring stem seals. All valve handles shall be polypropylene with built-in lockout mechanism. All valve union nuts shall have Buttress threads. All seal carriers shall be Safe-T-Blocked®. All valve components shall be replaceable. All EPDM valves shall be certified by NSF International for use in potable water service. All 1/2" through 4" valves shall be pressure rated to 235 psi, all 6" and 8" Venturied and all flanged valves shall be pressure rated to 150 psi for water at 73°F.

### Quick-View Valve Selection Chart

Valve Size	O-ring Material	PVC Part Number <sup>1,2</sup>					Pressure Rating	
		Socket	Threaded	SR Threaded	Flanged	Spigot		
1/2	EPDM	1829-005	included	1821-005SR	1823-005	1827-005	235 psi Non-Shock Water @ 73°F	
	FKM	1839-005	included	1831-005SR	1833-005	1837-005		
3/4	EPDM	1829-007	included	1821-007SR	1823-007	1827-007		
	FKM	1839-007	included	1831-007SR	1833-007	1837-007		
1	EPDM	1829-010	included	1821-010SR	1823-010	1827-010		
	FKM	1839-010	included	1831-010SR	1833-010	1837-010		
1-1/4	EPDM	1829-012	included	1821-012SR	1823-012	1827-012		
	FKM	1839-012	included	1831-012SR	1833-012	1837-012		
1-1/2	EPDM	1829-015	included	1821-015SR	1823-015	1827-015		
	FKM	1839-015	included	1831-015SR	1833-015	1837-015		
2	EPDM	1829-020	included	1821-020SR	1823-020	1827-020		(Flanged 150 psi Non-Shock) Water @ 73°F
	FKM	1839-020	included	1831-020SR	1833-020	1837-020		
2-1/2	EPDM	1822-025	1821-025	1821-025SR	1823-025	1827-025		
	FKM	1832-025	1831-025	1831-025SR	1833-025	1837-025		
3	EPDM	1822-030	1821-030	1821-030SR	1823-030	1827-030		
	FKM	1832-030	1831-030	1831-030SR	1833-030	1837-030		
4	EPDM	1822-040	1821-040	1821-040SR	1823-040	1827-040		
	FKM	1832-040	1831-040	1831-040SR	1833-040	1837-040		
6	EPDM	1822-060	1821-060	1821-060SR	1823-060	1827-060		
	FKM	1832-060	1831-060	1831-060SR	1833-060	1837-060		
8 <sup>3</sup>	EPDM	1822-080	—	—	1823-080	—	150 psi Non-Shock Water @ 73°F	
	FKM	1832-080	—	—	1833-080	—		

1) For CPVC, add the letter "C" following the size code of part number listed (e.g., 1829-005C, 1821-005CSR)  
 2) For Special Ball Vent Design, add the letter "V" before the dash separator (e.g., 1829V-005, 1821V-005CSR)  
 3) 8" Venturied Valves are 6" ball valves fitted with 6x8 end connector adapters.

- Chemical & Corrosion Resistant PVC or CPVC Construction
- Also Available in Spears® High Purity, Low Extractable PVC Material
- Interchangeable with all True Union 2000 Valves Mates with Union 2000 Pipe Unions
- High Impact Polypropylene Handle
- Built-in Handle Lockout
- Schedule 80 Full-Bore Design
- Strong, Buttress Thread Union Nuts
- Spears® Double O-ring Safe-T-Shear® Stem Design
- EPDM or FKM O-rings
- Spears® Safe-T-Blocked® Seal Carrier
- Self Adjusting PTFE Floating Seat Design
- Fully Serviceable, Replaceable Components
- Sizes 1/2" - 4" pressure rated to 235 psi @ 73°F. Sizes 6" and 8" Venturied and all Flanged to 150 psi @ 73°F.
- EPDM Valves NSF® Certified for Potable Water use
- Suitable for Vacuum Service
- Assembled with Silicone-Free, Water Soluble Lubricants
- Manufactured to ASTM F 1970

### Optional Vented Ball Valves

Same valve with special ball vent design for sodium hypochlorite (bleach) and other chemical applications where entrapped fluids may form caustic crystalline residues and pressure build up from gases developed. Valve has a 1/8" vent hole in ball to equalize internal fluid pressures. Install valve with ball vent on the pressure (upstream) side when in closed position.



### Optional Accessories\*

- Retro-Fit End Connector Sets for Valve Replacement
- Split-Nut Repair Kits for Union Nut Replacement
- Supplemental End Connectors
- Round Safety Handles
- Handle Lockout Ring
- Stem Extension Kits
- Square Operator Nuts
- Multi Mount Valve/Actuation Mounting Kits
- Mini-Mount Actuation Mounting Kits

\* See "BALL VALVE ACCESSORIES" section for details of individual products.



## Thermoplastic Valves Product Guide & Engineering Specifications

### True Union 2000 Industrial Ball Valves

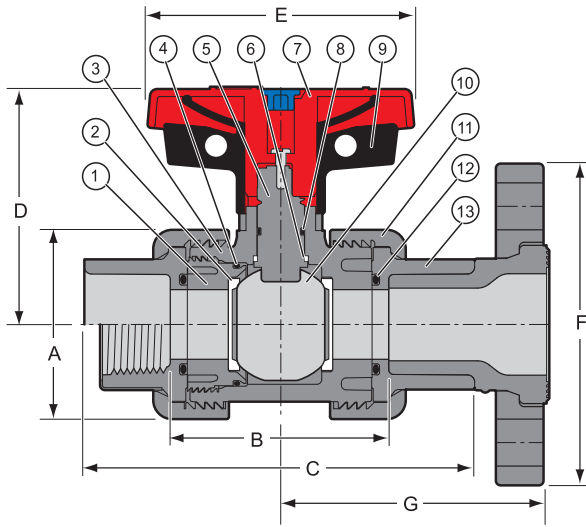

### Replacement Parts

No.	Component	Qty.	Material
1	Seal Carrier	1	PVC/CPVC
2	Seat	2	PTFE
3	Body	1	PVC/CPVC
4	Carrier O-ring	1	EPDM/FKM
5	Stem	1	PVC/CPVC
6	Stem Bearing	1	PP
7	Handle	1	PP
8	Stem O-ring	2	EPDM/FKM
9	Handle Lock	1	PP
10	Ball	1	PVC/CPVC
11	Union Nut	2	PVC/CPVC
12	End Connector O-ring	2	EPDM/FKM
13	End Connector	2	PVC/CPVC

### Dimensions, Weights, Operating Torque & Cv Values

Nominal Size	Dimensions Reference (inches, ± 1/16)										Approx. Wt. (Lbs.)		Oper. <sup>2</sup> Torque (in. lbs.)	Cv <sup>3</sup> Values		
	A	B <sup>1</sup>		C			D	E	F	G	PVC	CPVC		Soc/Thd	Flanged	Spigot
		Soc/Thd	Spigot	Socket	Thread	Spigot										
1/2	1-7/8	2-3/8	2-7/8	4-3/16	3-3/16	4-5/8	2-9/16	2-13/16	3-1/2	2-31/32	.36	.38	16	29	18	27
3/4	2-1/4	2-3/4	3-1/4	4-3/4	4-1/4	5-1/4	2-7/8	3-3/8	3-7/8	3-5/16	.56	.58	17	63	39	57
1	2-1/2	2-7/8	3-1/2	5-1/8	4-11/16	5-3/4	3-1/8	3-7/16	4-1/2	3-5/8	.74	.77	22	120	73	108
1-1/4	3-1/16	3-1/4	3-13/16	5-3/4	5-3/16	6-5/16	3-5/8	3-7/8	4-5/8	3-31/32	1.13	1.19	28	243	151	223
1-1/2	3-1/2	3-1/2	4	6-1/4	5-7/16	6-3/4	4	4-3/16	5	4-3/8	1.54	1.60	61	357	223	333
2	4-5/16	4-25/32	5-3/16	7-3/4	7-13/16	8-1/4	4-1/2	5-3/32	6	5-1/4	2.72	2.85	77	599	395	571
2-1/2	5-3/8	6-7/8	7-13/16	10-7/16	9-11/16	11-3/8	5-1/8	6-1/4	7-1/2	6	7.42	7.70	132	856	579	734
3	6-3/16	7	7-13/16	10-11/16	9-7/8	11-9/16	5-7/8	7-5/8	7-1/2	6-13/16	7.46	7.81	132	1416	974	1322
4	7-3/4	7-5/16	8-1/4	11-7/8	10-1/4	12-3/4	6-3/4	9	9	7-1/2	12.35	12.48	396	2865	1952	2672
6	11-5/8	11-1/16	13	17-1/16	15-3/4	18-1/2	8-1/8	14-5/16	11-1/4	10-3/16	37.53	40.55	732	6638	4824	6149
8 <sup>4</sup>	11-5/8	23-3/16	---	31-7/8	---	---	8-1/8	14-5/16	13-1/2	17-13/16	50.84	55.92	732	N/A	N/A	N/A

1: Valve Lay Length

2: Torque required at valve maximum internal pressure rating, 5ft/sec. Flow velocity; due to adjustment differences during installation, actual values may vary.

3: Gallons per minute at 1 psi pressure drop. Valves calculated from laying length, based on derivative of Hazen-Williams equation with surface roughness factor of C=150.

4: 8" Venturied Valves are 6" ball valves fitted with 6x8 end connector adapters.

### Temperature Pressure Rating

System Operating Temperature °F (°C)		100 (38)	110 (43)	120 (49)	130 (54)	140 (60)	150 (66)	160 (71)	170 (77)	180 (82)	190 (88)	200 (93)	210 (99)	
Valve Pressure Rating (psi) (MPa)	1/2" - 4"	PVC	235 (1.62)	211 (1.45)	150 (1.03)	75 (.52)	50 (.34)	-0- (-0-)	-0- (-0-)	-0- (-0-)	-0- (-0-)	-0- (-0-)	-0- (-0-)	
		CPVC	235 (1.62)	219 (1.51)	170 (1.17)	145 (1.00)	130 (.90)	110 (.76)	90 (.62)	80 (.55)	70 (.48)	60 (.41)	50 (.34)	-0- (-0-)
	6" and 8"	PVC	150 (1.03)	135 (.93)	110 (.76)	75 (.52)	50 (.34)	-0- (-0-)	-0- (-0-)	-0- (-0-)	-0- (-0-)	-0- (-0-)	-0- (-0-)	-0- (-0-)
		CPVC	150 (1.03)	140 (.97)	130 (.90)	120 (.83)	110 (.76)	100 (.70)	90 (.62)	80 (.55)	70 (.48)	60 (.41)	50 (.34)	-0- (-0-)

**NOTE:** Flanged Valves have a base pressure rating of 150 psi.

Thermoplastic Valves Product Guide & Engineering Specifications  
**True Union 2000 Industrial 3-Way Ball Valves**



**Quick-View Valve Selection Chart**  
**3-Way Vertical Ball Valve**

Valve Size	O-ring Material	PVC Part Number <sup>1, 2, 3, 4</sup>				Pressure Rating	
		Socket	SR Threaded	Flanged	Spigot		
1/2	EPDM	4722L1-005	4721L1-005SR	4723L1-005	4727L1-005	235 psi Non-Shock Water @ 73°F	
	FKM	4732L1-005	4731L1-005SR	4733L1-005	4737L1-005		
3/4	EPDM	4722L1-007	4721L1-007SR	4723L1-007	4727L1-007		
	FKM	4732L1-007	4731L1-007SR	4733L1-007	4737L1-007		
1	EPDM	4722L1-010	4721L1-010SR	4723L1-010	4727L1-010		
	FKM	4732L1-010	4731L1-010SR	4733L1-010	4737L1-010		
1-1/4	EPDM	4722L1-012	4721L1-012SR	4723L1-012	4727L1-012		(Flanged 150 psi Non-Shock) Water @ 73°F
	FKM	4732L1-012	4731L1-012SR	4733L1-012	4737L1-012		
1-1/2	EPDM	4722L1-015	4721L1-015SR	4723L1-015	4727L1-015		(Flanged 150 psi Non-Shock) Water @ 73°F
	FKM	4732L1-015	4731L1-015SR	4733L1-015	4737L1-015		
2	EPDM	4722L1-020	4721L1-020SR	4723L1-020	4727L1-020		(Flanged 150 psi Non-Shock) Water @ 73°F
	FKM	4732L1-020	4731L1-020SR	4733L1-020	4737L1-020		
2-1/2	EPDM	4722L1-025	4721L1-025SR	4723L1-025	4727L1-025	(Flanged 150 psi Non-Shock) Water @ 73°F	
	FKM	4732L1-025	4731L1-025SR	4733L1-025	4737L1-025		
3	EPDM	4722L1-030	4721L1-030SR	4723L1-030	4727L1-030	150 psi Non-Shock Water @ 73°F	
	FKM	4732L1-030	4731L1-030SR	4733L1-030	4737L1-030		
4	EPDM	4722L1-040	4721L1-040SR	4723L1-040	4727L1-040	150 psi Non-Shock Water @ 73°F	
	FKM	4732L1-040	4731L1-040SR	4733L1-040	4737L1-040		

- 1: For CPVC valve, add the letter "C" to the part number (e.g. 4722L1-005C)
- 2: For Double L-Port, add the number "2" to the part number (e.g. 4722L2-005)
- 3: For Triple L-Port, add the number "3" to the part number (e.g. 4722L3-005)
- 4: For T-Port, add the letter "T1" to the part number (e.g. 4722T1-005)

**Quick-View Valve Selection Chart**  
**3-Way Horizontal Diverter Valve (no branch shutoff)**

Valve Size	O-ring Material	PVC Part Number <sup>1, 2</sup>				Pressure Rating	
		Socket	SR Threaded	Flanged	Spigot		
1/2	EPDM	5022L1-005	5021L1-005SR	5023L1-005	5027L1-005	235 psi Non-Shock Water @ 73°F	
	FKM	5032L1-005	5031L1-005SR	5033L1-005	5037L1-005		
3/4	EPDM	5022L1-007	5021L1-007SR	5023L1-007	5027L1-007		
	FKM	5032L1-007	5031L1-007SR	5033L1-007	5037L1-007		
1	EPDM	5022L1-010	5021L1-010SR	5023L1-010	5027L1-010		235 psi Non-Shock Water @ 73°F
	FKM	5032L1-010	5031L1-010SR	5033L1-010	5037L1-010		
1-1/4	EPDM	5022L1-012	5021L1-012SR	5023L1-012	5027L1-012		(Flanged 150 psi Non-Shock) Water @ 73°F
	FKM	5032L1-012	5031L1-012SR	5033L1-012	5037L1-012		
1-1/2	EPDM	5022L1-015	5021L1-015SR	5023L1-015	5027L1-015		(Flanged 150 psi Non-Shock) Water @ 73°F
	FKM	5032L1-015	5031L1-015SR	5033L1-015	5037L1-015		
2	EPDM	5022L1-020	5021L1-020SR	5023L1-020	5027L1-020		(Flanged 150 psi Non-Shock) Water @ 73°F
	FKM	5032L1-020	5031L1-020SR	5033L1-020	5037L1-020		
2-1/2	EPDM	5022L1-025	5021L1-025SR	5023L1-025	5027L1-025	150 psi Non-Shock Water @ 73°F	
	FKM	5032L1-025	5031L1-025SR	5033L1-025	5037L1-025		
3	EPDM	5022L1-030	5021L1-030SR	5023L1-030	5027L1-030	150 psi Non-Shock Water @ 73°F	
	FKM	5032L1-030	5031L1-030SR	5033L1-030	5037L1-030		
4	EPDM	5022L1-040	5021L1-040SR	5023L1-040	5027L1-040	150 psi Non-Shock Water @ 73°F	
	FKM	5032L1-040	5031L1-040SR	5033L1-040	5037L1-040		

- 1: For CPVC valve, add the letter "C" to the part number (e.g. 5022L1-005C)
- 2: For T-Port, add the letter "T1" to the part number (e.g. 5022T1-005)





## Thermoplastic Valves Product Guide & Engineering Specifications

### True Union 2000 Industrial 3-Way Ball Valves

### Features – PVC, CPVC

Versatile design provides multiple port and configuration options for controlling flow distribution in industrial and chemical processing applications. Choose Vertical 3-Way (L-Port Diverter, T-Port Off) or Horizontal Diverter configurations with open branch (no shutoff) design. Valves are available in IPS sizes 1/2" through 4" with socket, SR threaded (Special Reinforced), flanged or spigot end connectors. Venturied 6" (4" valves with 4 x 6 reducers) are also available with socket or flanged valve end connections.

- Chemical & Corrosion Resistant PVC or CPVC Construction
- Vertical 3-Way or Horizontal Diverter Design (no branch shutoff)
- L-Port, Multi L-Port & T-Port Ball Configuration Options
- Interchangeable with all True Union 2000 Valves, Mates with Union 2000 Pipe Unions
- High Impact Polypropylene Handle
- Built-in Handle Lockout
- Strong, Buttress Thread Union Nuts
- Spears® Double O-ring Safe-T-Shear® Stem Design
- EPDM or FKM O-rings
- Spears® Safe-T-Blocked® Seal Carrier
- Self Adjusting PTFE Floating Seat Design
- Fully Serviceable, Replaceable Components
- Sizes 1/2" - 2" pressure rated to 235 psi @ 73°F  
Sizes 2-1/2" - 4" and all Flanged to 150 psi @ 73°F
- EPDM Valves NSF® Certified for Potable Water use
- Suitable for Vacuum Service
- Assembled with Silicone-Free, Water Soluble Lubricants
- Manufactured to ASTM F 1970
- Metric Socket and BSP Thread Available

### 3-Way Port Options

Diverter Valves have no shut-off on branch.

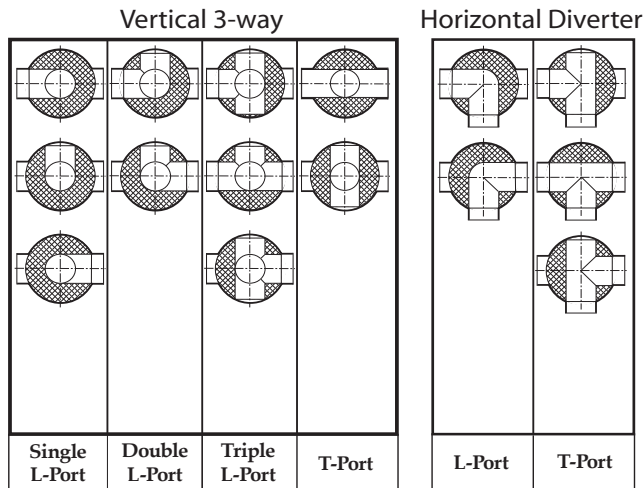

Ball Port Options viewed from top of valve.

### Optional Accessories\*

- Retro-Fit End Connector Sets for Valve Replacement
- Split-Nut Repair Kits for Union Nut Replacement
- Supplemental End Connectors
- Stem Extension Kits
- Square Operator Nuts
- Multi Mount Valve/Actuation Mounting Kits

\* See "BALL VALVE ACCESSORIES" section for details of individual products.

### Sample Engineering Specification

All thermoplastic ball valves shall be True Union 2000 3-Way [specify horizontal or vertical] type with [specify port option] manufactured to ASTM F 1970 and constructed from PVC Type I, ASTM D 1784 Cell Classification 12454, or CPVC Type IV, ASTM D 1784 Cell Classification 23447. All O-rings shall be EPDM or FKM. All valves shall have Safe-T-Shear® stem with double O-ring stem seals. All valve handles shall be polypropylene with built-in lockout mechanism. All valve union nuts shall have Buttress threads. All seal carriers shall be Safe-T-Blocked®. All valve components shall be replaceable. All EPDM valves shall be certified by NSF International for use in potable water service. All PVC and CPVC 1/2" through 2" valves shall be pressure rated to 235 psi, all 2-1/2" through 4" and all flanged valves shall be pressure rated to 150 psi for water at 73°F as manufactured by Spears® Manufacturing Company.



### Replacement Parts

No.	Component	Qty.	Material
1	End Connector	3	PVC/CPVC
2	End Connector O-ring	3	EPDM/FKM
3	Union Nut	3	PVC/CPVC
4	Handle Lock	1	PP
5	Handle	1	PP
6	Stem	1	PVC/CPVC
7	Screw	1	Stainless Steel
8	Handle Cover	1	PP
9	Stem O-ring	2	EPDM/FKM
10	Stem Bearing*	1	PTFE
11	Body	1	PVC/CPVC
12	Ball	1	PVC/CPVC
13	End Connector Collar	3	Stainless Steel
14	Seat	2	PTFE
15	Carrier O-ring	1	EPDM/FKM
16	Seal Carrier	1	PVC/CPVC

**Note:** Applies to both Vertical and Horizontal configurations.  
 \* For sizes 2-1/2, 3 & 4 only.

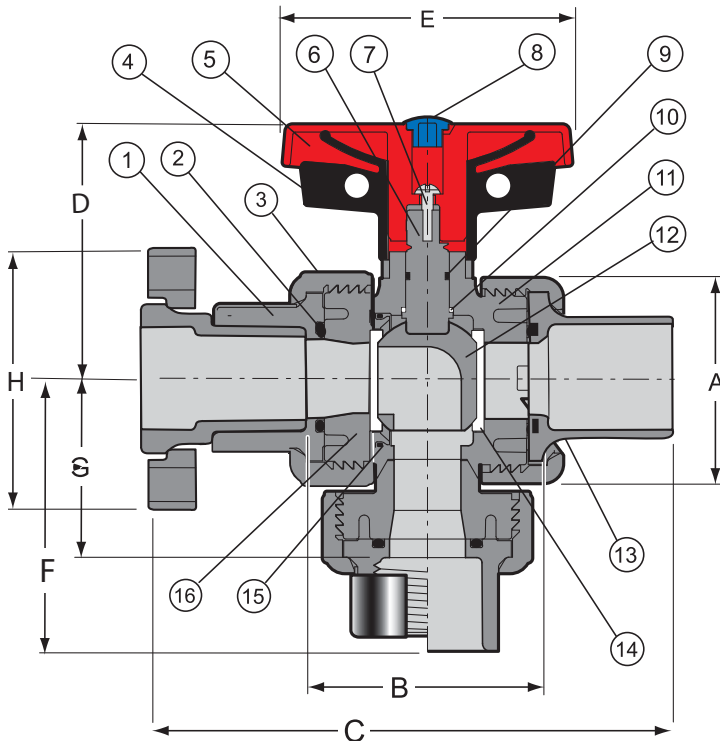

**NOTE:** Diverter style valve has no shutoff on branch.

### Vertical 3-Way Ball Valves — Dimensions & Operating Torque

Vertical 3 Way Ball Valve															Oper. <sup>2</sup> Torque (in. lbs.)
Nominal Size	A	B <sup>1</sup>		C			D	E	F			G		H	
		Soc/SR Thd	Spigot	Socket	SR Thd	Spigot			Socket	SR Thread	Spigot	Soc/SR Thd	Spigot		
1/2	1-7/8	2-7/16	2-15/16	4-1/4	3-27/32	4-3/4	2-9/16	2-13/16	2-3/4	2-9/16	2-13/16	1-11/16	2	3-1/2	12
3/4	2-1/4	2-3/4	3-5/16	4-3/4	4-1/4	5-3/8	2-7/8	3-5/16	3	2-3/4	3-5/16	2	2-5/16	3-7/8	12
1	2-1/2	2-7/8	3-1/2	5-1/8	4-11/16	5-3/4	3-1/8	3-7/16	3-1/4	3	3-9/16	2-1/8	2-7/16	4-1/4	20
1-1/4	3-1/16	3-1/4	3-13/16	5-3/4	5-3/16	6-5/16	3-5/8	3-13/16	3-3/4	3-3/8	4-1/16	2-3/8	2-13/16	4-5/8	25
1-1/2	3-1/2	3-1/2	4	6-1/4	5-7/16	6-3/4	4	4-3/16	4-3/16	3-13/16	4-1/2	2-3/16	3-1/8	5	40
2	4-1/4	4-3/4	5-3/16	7-3/4	6-3/4	8-1/4	4-1/2	5-1/8	5	4-1/2	5-5/16	3-1/2	3-3/4	6	67
2-1/2	5-3/8	5-7/8	7-13/16	9-5/16	8-1/2	11-3/8	5-1/8	6-1/4	5-7/8	5-1/2	6-7/16	4-1/8	5-5/16	7-1/2	120
3	6-3/16	6-7/8	7-13/16	10-11/16	9-3/4	11-9/16	5-7/8	7-5/8	6-11/16	6-3/16	7-3/16	4-3/4	5-5/16	7-1/2	120
4	7-1/2	7-1/4	8-1/4	11-13/16	10-1/4	12-13/16	6-3/4	9-3/16	7-1/8	6-3/4	8-3/4	5-7/8	6-1/2	9	336

1: Valve Lay Length

2: Torque required at valve maximum internal pressure rating, 5ft/sec. Flow velocity; due to adjustment differences during installation, actual values may vary.





## Thermoplastic Valves Product Guide & Engineering Specifications True Union 2000 Industrial 3-Way Ball Valves

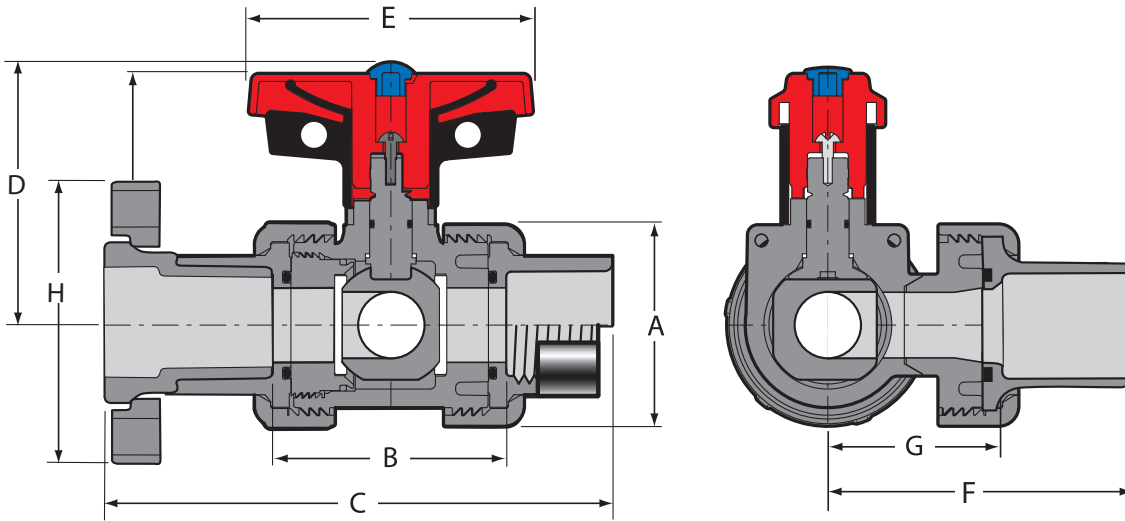

**NOTE:** Diverter style valve has no shutoff on branch

### Horizontal Diverter 3-Way Ball Valves Dimensions & Operating Torque

Nominal Size	A	B <sup>1</sup>		C			D	E	F			G		H	Oper. <sup>2</sup> Torque (in. lbs.)
		Soc/SR Thread	Spigot	Socket	SR Thread	Spigot			Socket	SR Thread	Spigot	Soc/SR Thread	Spigot		
1/2	1-3/16	2-7/16	2-15/16	4-3/16	3-13/16	4-3/4	2-9/16	2-13/16	2-9/16	2-3/8	2-13/16	1-11/16	2	3-1/2	12
3/4	2-1/4	2-3/4	3-15/16	4-3/4	4-1/4	5-3/8	2-7/8	3-5/16	3	2-3/4	3-5/16	2	2-5/16	3-7/8	12
1	2-1/2	2-7/8	3-1/2	5-1/8	4-11/16	5-3/4	3-1/8	3-7/16	3-1/4	3	3-9/16	2-1/8	2-7/16	4-1/4	20
1-1/4	3-1/16	3-1/4	3-13/16	5-3/4	5-3/16	6-5/16	3-5/8	3-13/16	3-3/4	3-3/8	4-1/16	2-3/8	2-13/16	4-5/8	25
1-1/2	3-1/2	3-1/2	4	6-1/4	5-7/16	6-3/4	4	4-3/16	4-3/16	3-13/16	4-1/2	2-3/16	3-1/8	5	40
2	4-1/4	4-3/4	5-3/16	7-3/4	6-3/4	8-1/4	4-1/2	5-1/8	5	4-1/2	5-5/16	3-1/2	3-3/4	6	67
2-1/2	5-3/8	5-7/8	7-13/16	9-5/16	8-1/2	11-3/8	5-1/8	6-1/4	5-7/8	5-1/2	6-7/16	4-1/8	5-5/16	7-1/2	120
3	6-3/16	6-7/8	7-13/16	10-11/16	9-3/4	11-9/16	5-7/8	7-5/8	6-11/16	6-3/16	7-3/16	4-3/4	5-5/16	7-1/2	120
4	7-1/2	7-1/4	8-1/4	11-13/16	10-1/4	12-13/16	6-3/4	9-3/16	7-1/8	6-3/4	8-3/4	5-7/8	6-1/2	9	336

1: Valve Lay Length

2: Torque required at valve maximum internal pressure rating, 5ft/sec. Flow velocity; due to adjustment differences during installation, actual values may vary.

### Temperature Pressure Rating

System Operating Temperature °F (°C)		100 (38)	110 (43)	120 (49)	130 (54)	140 (60)	150 (66)	160 (71)	170 (77)	180 (82)	190 (88)	200 (93)	210 (99)	
Valve Pressure Rating psi (MPa)	1/2" - 2"	PVC	235 (1.62)	211 (1.45)	150 (1.03)	75 (.52)	50 (.34)	-0- (-0-)	-0- (-0-)	-0- (-0-)	-0- (-0-)	-0- (-0-)	-0- (-0-)	
		CPVC	235 (1.62)	219 (1.51)	170 (1.17)	145 (1.00)	130 (.90)	110 (.76)	90 (.62)	80 (.55)	70 (.48)	60 (.41)	50 (.34)	-0- (-0-)
	2-1/2" - 4"	PVC	150 (1.03)	135 (.93)	110 (.76)	75 (.52)	50 (.34)	-0- (-0-)	-0- (-0-)	-0- (-0-)	-0- (-0-)	-0- (-0-)	-0- (-0-)	-0- (-0-)
		CPVC	150 (1.03)	140 (.97)	130 (.90)	120 (.83)	110 (.76)	100 (.70)	90 (.62)	80 (.55)	70 (.48)	60 (.41)	50 (.34)	-0- (-0-)

**NOTE:** Flanged Valves have a base pressure rating of 150 psi.



Tee x Socket

## Features – PVC, CPVC

Spears® True Union 2000 Industrial Tee-Style Ball Valve design integrates valve and Tee-fitting for direct branch take-off laterals. The “Tee-Valve” provides a stronger, more compact connection by eliminating the need for a reducer, additional length of pipe, and one of the end connections on the ball valve. Close proximity of valve to mainline emulates a “zero dead-leg” design to minimize any areas of fluid stagnation. Custom produced to specified Tee and Valve connection sizes. Also available in metric sizes.

- Chemical & Corrosion Resistant PVC, CPVC or Low Extractable PVC materials
- Multi-featured Industrial Grade
- Built-in Handle Lockout
- Fully Serviceable, Replaceable Components
- Seal Carrier Adjustment Tool included
- ISO Pattern Actuation Mounting Option
- Spears® Dual O-ring Safe-T-Shear® Stem
- Self Adjusting PTFE Floating Seat
- Sizes 1/2" - 2" Pressure Rated to 235 psi @ 73°F
- EPDM Valves NSF® Certified for Potable Water Use



## Sample Engineering Specification

All lateral branch valve connections shall be made using integrated Tee-style ball valve and Tee fitting. Tee-style ball valves shall be True Union 2000 Industrial type manufactured to ASTM F 1970 and constructed from PVC Type I, ASTM D 1784 Cell Classification 12454 or CPVC Type IV, ASTM D 1784 Cell Classification 23447; or Low Extractable PVC, ASTM D 1784 Cell Classification 12343. All O-rings shall be EPDM or FKM. All valves shall have Safe-T-Shear® stem with double O-ring stem seals. All valve handles shall be polypropylene with built-in lockout. All valve union nuts shall have Buttress threads. All seal carriers shall be Safe-T-Blocked®. All valve components shall be replaceable. Mainline Tee fittings shall be Schedule 80 manufactured in accordance with ASTM D 2467 for PVC or F 439 for CPVC. All EPDM valves shall be certified by NSF International for use in potable water service. All 1/2" through 2" valves shall be pressure rated to 235 psi for water at 73°F, as manufactured by Spears® Manufacturing Company.



Thermoplastic Valves Product Guide & Engineering Specifications  
**True Union 2000 Industrial Tee Style Ball Valves**

**Quick-View Valve Selection Chart**

**T-Valves can be custom produced in any standard Tee and Valve size combination**

Size (Tee x Valve Outlet)	PVC		CPVC	
	EPDM	FKM	EPDM	FKM
1/2	182901-005	183901-005	182901-005C	183901-005C
3/4	182901-007	183901-007	182901-007C	183901-007C
1	182901-010	183901-010	182901-010C	183901-010C
1-1/4	182901-012	183901-012	182901-012C	182901-012C
1-1/2	182901-015	183901-015	182901-015C	183901-015C
2	182901-020	183901-020	182901-020C	183901-020C
3/4x1/2	182901-101	183901-101	182901-101C	183901-101C
1x1/2	182901-130	183901-130	182901-130C	183901-130C
1x3/4	182901-131	183901-131	182901-131C	183901-131C
1-1/4x1/2	182901-166	183901-166	182901-166C	182901-166C
1-1/4x3/4	182901-167	183901-167	182901-167C	183901-167C
1-1/4x1	182901-168	183901-168	182901-168C	183901-168C
1-1/2x1/2	182901-209	183901-209	182901-209C	183901-209C
1-1/2x3/4	182901-210	183901-210	182901-210C	183901-210C
1-1/2x1	182901-211	183901-211	182901-211C	183901-211C
2x1/2	182901-247	183901-247	182901-247C	183901-247C
2x3/4	182901-248	183901-248	182901-248C	183901-248C
2x1	182901-249	183901-249	182901-249C	183901-249C
2x1-1/2	182901-251	183901-251	182901-251C	183901-251C
3x1/2	182901-333	183901-333	182901-333C	183901-333C
3x1	182901-335	183901-335	182901-335C	183901-335C
3x1-1/2	182901-337	183901-337	182901-337C	183901-337C
3x2	182901-338	183901-338	182901-338C	183901-338C
4x1	182901-417	183901-417	182901-417C	183901-417C
4x1-1/2	182901-419	183901-419	182901-419C	183901-419C
4x2	182901-420	183901-420	182901-420C	183901-420C
6x2	182901-528	183901-528	182901-528C	183901-528C
8x2	182901-578	183901-578	182901-578C	183901-578C

**Additional Notes:** For Low Extractable PVC valves, add the letters BL to the part number (e.g. 182901-005BL)  
 Valve assembly includes debris plug in valve socket end (to be removed on installation) and cable-tie affixed spare end connector.

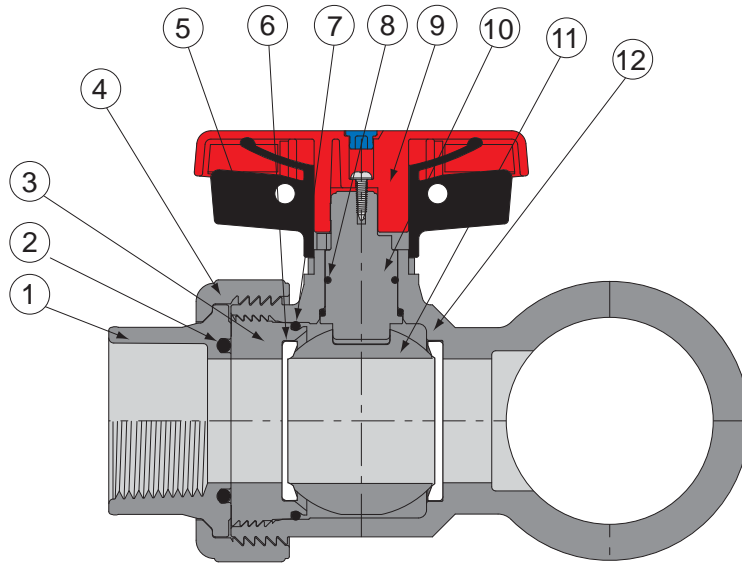

### Replacement Parts

No.	Component	Qty.	Material
1	End Connector	1	PVC/CPVC
2	End Connector O-ring	1	EPDM/FKM
3	Seal Carrier	1	PVC/CPVC
4	Union Nut	3	PVC/CPVC
5	Handle Lock	1	PP
6	Seat	2	PTFE
7	Carrier O-ring	1	EPDM/FKM
8	Stem O-ring	2	EPDM/FKM
9	Handle	1	PP
10	Stem	1	PVC/CPVC
11	Ball	1	PVC/CPVC
12	Body	1	PVC/CPVC



### Temperature Pressure Rating

System Operating Temperature °F (°C)		100 (38)	110 (43)	120 (49)	130 (54)	140 (60)	150 (66)	160 (71)	170 (77)	180 (82)	190 (88)	200 (93)	210 (99)
Valve Pressure Rating psi (MPa)	1/2" - 2"	PVC	235 (1.62)	211 (1.45)	150 (1.03)	75 (.52)	50 (.34)	-0- (-0-)	-0- (-0-)	-0- (-0-)	-0- (-0-)	-0- (-0-)	-0- (-0-)
	CPVC	235 (1.62)	219 (1.51)	170 (1.17)	145 (1.00)	130 (.90)	110 (.76)	90 (.62)	80 (.55)	70 (.48)	60 (.41)	50 (.34)	-0- (-0-)



## Thermoplastic Valves Product Guide & Engineering Specifications True Union 2000 Industrial Tee Style Ball Valves

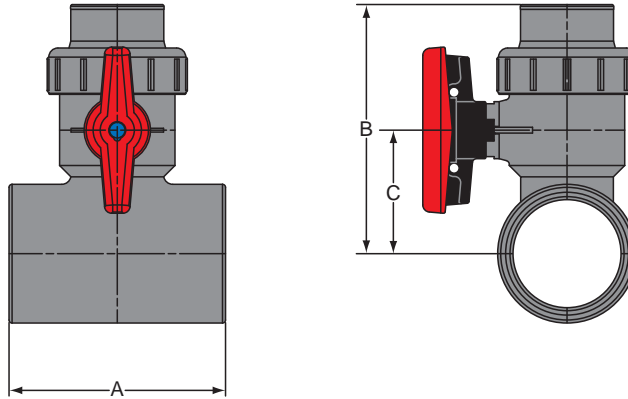

### Dimensions, Operating Torque & Cv Values

Nominal Size	Dimensions Reference (inches, ± 1/16)				Approx. Wt. (Lbs.)		Oper. <sup>1</sup> Torque (in. lbs.)	Cv <sup>2</sup> (Value only)
	A	B		C	PVC	CPVC		
		Socket	Threaded					
1/2	2-5/16	3-3/4	3-9/16	1-5/8	.48	.52	16	29
3/4	3-7/16	4-1/4	4	1-7/8	.70	.77	17	63
1	4	4-11/16	4-7/16	2-1/16	1.10	1.15	22	120
1-1/4	4-1/4	5-5/16	5	2-7/16	1.64	1.73	28	243
1-1/2	5-1/8	6-1/8	5-11/16	3	2.26	2.37	61	357
2	5-7/8	7-5/16	6-13/16	3-7/16	3.72	3.82	77	599
3/4x1/2	4	3-7/8	3-11/16	1-3/4	.51	.54	16	29
1x1/2	3-7/16	4	3-13/16	1-7/8	.58	.61	16	29
1x3/4	3-11/16	4-3/8	4-1/2	2	.78	.80	17	63
1-1/4x1/2	4-1/4	4	3-13/16	1-7/8	.77	.80	16	29
1-1/4x3/4	4-1/4	4-1/4	4	1-7/8	.90	.94	17	63
1-1/4x1	4-1/4	4-13/16	4-5/8	2-3/16	1.78	1.96	22	120
1-1/2x1/2	4-3/8	4-1/4	4-1/16	2-1/8	.86	.89	16	29
1-1/2x3/4	4-1/8	4-5/8	4-3/8	2-3/16	.91	.94	16	63
1-1/2x1	4-1/2	5	4-13/16	2-3/8	1.37	1.51	16	120
2x1/2	4-3/16	4-9/16	4-3/8	2-7/16	1.06	1.17	16	29
2x3/4	4-3/8	4-15/16	4-11/16	2-9/16	1.23	1.28	17	63
2x1	4-3/4	5-1/4	5-1/16	2-5/8	1.38	1.45	22	120
2x1-1/2	5-7/8	6-1/16	5-7/8	2-15/16	2.33	2.63	61	29
3x1/2	5-1/2	5-1/8	4-15/16	3	1.60	1.66	16	29
3x1	5-1/2	5-7/8	5-11/16	3-1/4	2.19	2.25	22	120
3x1-1/2	7-1/4	6-9/16	6-3/8	3-7/16	3.66	3.87	61	357
3x2	6-11/16	7-11/16	7-3/16	3-13/16	4.61	4.86	77	599
4x1	7-7/16	6-5/16	6-1/8	3-11/16	3.25	3.52	22	120
4x1-1/2	7-3/8	7-5/16	7-1/8	4-3/16	4.01	4.37	61	357
4x2	7-3/4	8-5/16	7-3/4	4-7/16	5.20	5.68	77	599
6x2	10-3/16	9-5/8	9-1/8	5-3/4	9.26	11.68	77	599
8x2	15-5/8	12-5/8	12-1/8	8-3/4	17.42	18.70	77	599

1: Torque required at valve maximum internal pressure rating, 5ft/sec. Flow velocity; due to adjustment differences during installation, actual valves may vary.  
 2: Gallons per minute at 1 psi pressure drop. Valves calculated from laying length, based on derivative of Hazen-Williams equation with surface roughness factor of C=150.  
 Cv values are for basic Ball Valve only, excluding Tee end connection.



### Features – PVC, CPVC

Flow tested design provides quick response with positive seal for prevention of system back flow in industrial and chemical processing applications. Valves are available in IPS sizes 1/2" through 6" with socket/regular thread, SR threaded (Special Reinforced), flanged or spigot end connectors and 8" venturied valve with socket or flanged ends. Also available in metric socket and BSP thread sizes 1/2" through 2".

### Sample Engineering Specification

All thermoplastic check valves shall be True Union 2000 Industrial Ball Check type manufactured to ASTM F 1970 and constructed from PVC Type I, ASTM D 1784, Cell Classification 12454 or CPVC Type IV, ASTM D 1784 Cell Classification 23447. All O-rings shall be EPDM or FKM. All valve union nuts shall have Buttress threads. All valve seats shall be a standard O-ring type. All seal carriers shall be Safe-T-Blocked®. All valve components shall be replaceable. All EPDM valves shall be listed by NSF® for use in potable water service. All PVC and CPVC 1/2" through 4" valves shall be pressure rated to 235 psi, all 6" and 8" Venturied and all flanged valves shall be pressure rated to 150 psi for water at 73°F as manufactured by Spears® Manufacturing Company.

- Chemical & Corrosion Resistant PVC or CPVC Construction
- Also Available in Spears® High Purity, Low Extractable PVC Material
- Strong, Buttress Thread Union Nuts
- Spears® Safe-T-Blocked® Seal Carrier
- Uses Standard O-ring Seat
- EPDM or FKM O-rings
- Fully Serviceable, Replaceable Components
- Sizes 1/2" - 4" Pressure Rated to 235 psi @ 73°F, Sizes 6" and 8" Venturied and all Flanged Pressure Rated to 150 psi @ 73°F
- Suitable for Either Horizontal or Vertical Installations
- EPDM valves NSF® Certified for Potable Water use
- Suitable for Vacuum Service
- Assembled with Silicone-Free, Water Soluble Lubricants
- Manufactured to ASTM F 1970

### Quick-View Valve Selection Chart

Valve Size	O-ring Material	PVC Part Number <sup>1</sup>					Pressure Rating	
		Socket	Threaded	SR Threaded	Flanged	Spigot		
1/2	EPDM	4529-005	included	4521-005SR	4523-005	4527-005	235 psi Non-Shock Water @ 73°F	
	FKM	4539-005	included	4531-005SR	4533-005	4537-005		
3/4	EPDM	4529-007	included	4521-007SR	4523-007	4527-007		
	FKM	4539-007	included	4531-007SR	4533-007	4537-007		
1	EPDM	4529-010	included	4521-010SR	4523-010	4527-010		
	FKM	4539-010	included	4531-010SR	4533-010	4537-010		
1-1/4	EPDM	4529-012	included	4521-012SR	4523-012	4527-012		
	FKM	4539-012	included	4531-012SR	4533-012	4537-012		
1-1/2	EPDM	4529-015	included	4521-015SR	4523-015	4527-015		(Flanged 150 psi Non-Shock) Water @ 73°F
	FKM	4539-015	included	4531-015SR	4533-015	4537-015		
2	EPDM	4529-020	included	4521-020SR	4523-020	4527-020		
	FKM	4539-020	included	4531-020SR	4533-020	4537-020		
2-1/2	EPDM	4522-025	4521-025	4521-025SR	4523-025	4527-025		
	FKM	4532-025	4531-025	4531-025SR	4533-025	4537-025		
3	EPDM	4522-030	4521-030	4521-030SR	4523-030	4527-030		
	FKM	4532-030	4531-030	4531-030SR	4533-030	4537-030		
4	EPDM	4522-040	4521-040	4521-040SR	4523-040	4527-040		
	FKM	4532-040	4531-040	4531-040SR	4533-040	4537-040		
6	EPDM	4522-060	4521-060	4521-060SR	4523-060	4527-060	150 psi Non-Shock Water @ 73°F	
	FKM	4532-060	4531-060	4531-060SR	4533-060	4537-060		
8 <sup>2</sup>	EPDM	4522-080	—	—	4523-080	—		
	FKM	4532-080	—	—	4533-080	—		

1: For CPVC valve, add the letter "C" to the part number (e.g., 4529-005C, 4521-005CSR)  
 2: 8" Venturied Valves are 6" ball valves fitted with 6x8 end connector adapters

### Optional Accessories\*

- Retro-Fit End Connector Sets for Valve Replacement
- Split-Nut Repair Kits for Union Nut Replacement
- Supplemental End Connectors

\* See "BALL VALVE ACCESSORIES" section for details of individual products.



### Ball Check Foot Valves



Spears® Ball Check Valves easily convert to foot valves utilizing optional Foot Valve Screen adapters found in Ball Valve Accessories section.



## Thermoplastic Valves Product Guide & Engineering Specifications True Union 2000 Industrial Ball Check Valves

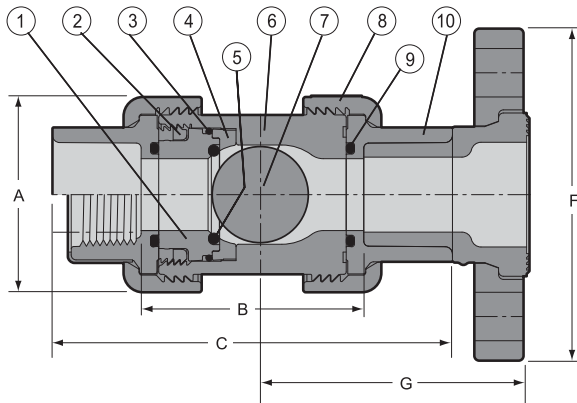

### Replacement Parts

No.	Component	Qty.	Material
1	Seal Carrier	1	PVC/CPVC
2	Seal Carrier Nut	1	PVC/CPVC
3	Carrier O-ring	1	EPDM/FKM
4	Seat Plate	1	PVC/CPVC
5	Seat O-ring	1	EPDM/FKM
6	Body	1	PVC/CPVC
7	Ball	1	PVC/CPVC
8	Union Nut	2	PVC/CPVC
9	End Connector O-ring	2	EPDM/FKM
10	End Connector	2	PVC/CPVC

### Dimensions, Weights, & Cv Values

Nominal Size	Dimensions Reference (inches, ± 1/16)								Approx. Wt. (Lbs.)		Cv Values			Horizontal Closing	
	A	B <sup>1</sup>		C			F	G	PVC	CPVC	Soc/Thd	Flange	Spigot	Feet of Head (water)	GPM (minimum)
		Soc/Thd	Spigot	Socket	Thread	Spigot									
1/2	1-7/8	2-7/16	2-7/8	4-3/16	3-13/16	4-5/8	3-1/2	2-31/32	.30	.33	6.3	6	6.3	1.6	.10
3/4	2-1/4	2-3/4	3-1/4	4-3/4	4-1/4	5-1/4	3-7/8	3-5/16	.46	.50	17	16	17	1.6	.10
1	2-1/2	2-7/8	3-1/2	5-1/8	4-11/16	5-3/4	4-1/4	3-5/8	.70	.74	25	24	25	1.6	.25
1-1/4	3-1/16	3-1/4	3-3/16	5-3/4	5-3/16	6-5/16	4-5/8	3-31/32	1.04	1.09	65	61	65	1.6	.40
1-1/2	3-1/2	3-1/2	4	6-1/4	5-7/16	6-3/4	5	4-3/8	1.37	1.45	86	82	86	1.6	.75
2	4-5/16	4-25/32	5-3/16	7-3/4	7-27/32	8-1/4	6	5-1/4	2.47	2.62	130	125	130	1.6	.75
2-1/2	6-3/16	5-7/8	7-13/16	9-5/16	8-1/2	11-3/8	7-1/2	6	6.80	7.25	200	193	200	1.0	1.50
3	6-3/16	6-7/8	7-13/16	10-11/16	9-3/4	11-9/16	7-1/2	6-13/16	6.98	7.35	275	268	275	1.0	4.00
4	7-3/4	7-5/16	8-1/4	11-13/16	10-1/4	12-3/4	9	7-1/2	12.13	12.96	500	489	500	1.0	5.50
6	11-5/8	11-1/6	13	17-1/16	15-3/4	18-1/2	11-1/4	10-3/16	37.07	39.98	800	794	800	N/A	N/A
8 <sup>3</sup>	11-5/8	23-3/16	---	31-7/8	---	---	13-1/2	17-13/16	50.84	55.92	N/A	N/A	N/A	N/A	N/A

1: Valve Lay Length

2: Gallons per minute at 1 psi pressure drop. Valves calculated from laying length, based on derivative of Hazen-Williams equation with surface roughness factor of C=150.

3: 8" Venturied Valves are 6" ball valves fitted with 6x8 end connector adapters



### Temperature Pressure Rating

System Operating Temperature °F (°C)		100 (38)	110 (43)	120 (49)	130 (54)	140 (60)	150 (66)	160 (71)	170 (77)	180 (82)	190 (88)	200 (93)	210 (99)	
Valve Pressure Rating psi (MPa)	1/2" - 4"	PVC	235 (1.62)	211 (1.45)	150 (1.03)	75 (.52)	50 (.34)	-0- (-0-)	-0- (-0-)	-0- (-0-)	-0- (-0-)	-0- (-0-)	-0- (-0-)	
		CPVC	235 (1.62)	219 (1.51)	170 (1.17)	145 (1.00)	130 (.90)	110 (.76)	90 (.62)	80 (.55)	70 (.48)	60 (.41)	50 (.34)	-0- (-0-)
	6" and 8"	PVC	150 (1.03)	135 (.93)	110 (.76)	75 (.52)	50 (.34)	-0- (-0-)	-0- (-0-)	-0- (-0-)	-0- (-0-)	-0- (-0-)	-0- (-0-)	-0- (-0-)
		CPVC	150 (1.03)	140 (.97)	130 (.90)	120 (.83)	110 (.76)	100 (.70)	90 (.62)	80 (.55)	70 (.48)	60 (.41)	50 (.34)	-0- (-0-)

**NOTE:** Flanged valves have a base pressure rating of 150 psi

**General Installation Information:** Ball check valves may be installed in either horizontal or vertical position. A minimum of ten (10) pipe diameters distance maintained from any pump or other source of turbulence. Check valves **MUST** be installed with the valves **FLOW** arrow pointing in the direction of flow.



### Sample Engineering Specification

All thermoplastic ball valves shall be True Union 2000 Standard type manufactured to ASTM F 1970 and constructed from PVC Type I, ASTM D 1784 Cell Classification 12454 or CPVC Type IV, ASTM D 1784 Cell Classification 23447. All O-rings shall be EPDM or FKM. All valves shall have Safe-T-Shear® stem with O-ring stem seal. All handles shall be polypropylene. All union nuts shall have Buttress threads. All seal carriers shall be Safe-T-Blocked®. All EPDM valves shall be certified by NSF International for use with potable water. All 1/2" - 2" valves shall be pressure rated to 235 psi, all 2-1/2" - 4" and all flanged valves to 150 psi for water @ 73°F, as manufactured by Spears® Manufacturing Company.

### Features – PVC, CPVC

Economical, low profile quarter-turn shutoff valve is excellent for general purpose and many O.E.M applications. PVC and CPVC valves are available in IPS sizes 1/2" through 4" with socket, regular thread, SR threaded (Special Reinforced), flanged or spigot end connectors.

- Chemical & Corrosion Resistant PVC or CPVC Construction
- Interchangeable with all True Union 2000 Valves, Mates with Union 2000 Pipe Unions
- High Impact Polypropylene Handle
- Schedule 80 Full-Bore Design
- Strong, Buttress Thread Union Nuts
- Spears® Single O-ring Safe-T-Shear® Stem Design
- Spears® Safe-T-Blocked® Seal Carrier
- Replaceable PTFE/HDPE Floating Seat Design
- EPDM or FKM O-rings
- Sizes 1/2" - 2" pressure rated to 235 psi @ 73°F
- Sizes 2-1/2" - 4" and all flanged pressure rated to 150 psi @ 73°F
- EPDM valves NSF® Certified for Potable Water use
- Suitable for Vacuum Service
- Assembled with Silicone-Free, Water Soluble Lubricants
- Manufactured to ASTM F 1970

### Quick-View Valve Selection Chart

Valve Size	O-ring Material	PVC Part Number <sup>1</sup>					Pressure Rating
		Socket	Threaded	SR Threaded	Flanged	Spigot	
1/2	EPDM	3629-005	included	3621-005SR	3623-005	3627-005	235 psi Non-Shock Water @ 73°F
	FKM	3639-005	included	3631-005SR	3633-005	3637-005	
3/4	EPDM	3629-007	included	3621-007SR	3623-007	3627-007	
	FKM	3639-007	included	3631-007SR	3633-007	3637-007	
1	EPDM	3629-010	included	3621-010SR	3623-010	3627-010	
	FKM	3639-010	included	3631-010SR	3633-010	3637-010	
1-1/4	EPDM	3629-012	included	3621-012SR	3623-012	3627-012	(Flanged 150 psi Non-Shock) Water @ 73°F
	FKM	3639-012	included	3631-012SR	3633-012	3637-012	
1-1/2	EPDM	3629-015	included	3621-015SR	3623-015	3627-015	
	FKM	3639-015	included	3631-015SR	3633-015	3637-015	
2	EPDM	3629-020	included	3621-020SR	3623-020	3627-020	
	FKM	3639-020	included	3631-020SR	3633-020	3637-020	
2-1/2	EPDM	3622-025	3621-025	3621-025SR	3623-025	3627-025	150 psi Non-Shock Water @ 73°F
	FKM	3632-025	3631-025	3631-025SR	3633-025	3637-025	
3	EPDM	3622-030	3621-030	3621-030SR	3623-030	3627-030	
	FKM	3632-030	3631-030	3631-030SR	3633-030	3637-030	
4	EPDM	3622-040	3621-040	3621-040SR	3623-040	3627-040	
	FKM	3632-040	3631-040	3631-040SR	3633-040	3637-040	

1: For CPVC valve, add the letter "C" to the part number (e.g., 3629-005C, 3621-005CSR)

### Optional Accessories\*

- Retro-Fit End Connector Sets for Valve Replacement
- Split-Nut Repair Kits for Union Nut Replacement
- Supplemental End Connectors
- Round Safety Handles
- Stem Extension Kits
- Square Operator Nuts
- Multi Mount Valve/ Actuation Mounting Kits
- Mini-Mount Actuation Mounting Kits

\* See "BALL VALVE ACCESSORIES" section for details of individual products.





## Thermoplastic Valves Product Guide & Engineering Specifications

### True Union 2000 Standard Ball Valves

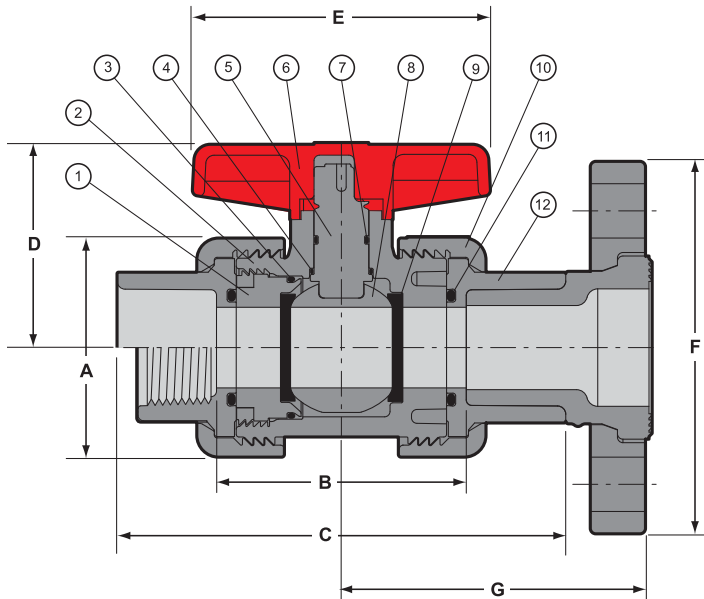

### Replacement Parts

No.	Component	Qty.	Material
1	Seal Carrier	1	PVC/CPVC
2	Body	1	PVC/CPVC
3	Carrier O-ring	1	EPDM/FKM
4	Stem Bearing 1,2	1	PP
5	Stem	1	PVC/CPVC
6	Handle	1	PP
7	Stem O-ring	1	EPDM/FKM
8	Ball	1	PVC/CPVC
9	Seat	2	PTFE/HDPE
10	Union Nut	2	PVC/CPVC
11	End Connector O-ring	2	EPDM/FKM
12	End Connector	2	PVC/CPVC

1: O-Ring up to 2"  
 2: PTFE Thrust Bearing: 2-1/2", 3" & 4"

### Dimensions, Weights, Operating Torque & Cv Values

Nominal Size	A	B <sup>1</sup>		C			D	E	F	G	Approx. Wt. (Lbs.)		Oper. <sup>2</sup> Torque (in. lbs.)	Cv Values <sup>3</sup>	
		Soc/Thd	Spigot	Socket	Thread	Spigot					PVC	CPVC		Soc/Thd/Spig	Flanged
		1/2	1-7/8	2-7/16	2-7/8	4-3/16					3-13/16	4-5/8		1-5/8	2-1/2
3/4	2-1/4	2-3/4	3-1/4	4-3/4	4-1/4	5-1/4	2	3	3-7/8	3-5/16	.51	.54	20	63	39
1	2-1/2	2-7/8	3-1/2	5-1/8	4-11/16	5-3/4	2-5/16	3-7/16	4-1/4	3-5/8	.71	.75	25	120	73
1-1/4	3-1/16	3-1/4	3-13/16	5-3/4	5-3/16	6-5/16	2-13/16	3-9/16	4-5/8	3-31/32	1.12	1.17	35	243	151
1-1/2	3-1/2	3-1/2	4	6-1/4	5-7/16	6-3/4	3-1/16	3-7/8	5	4-3/8	1.47	1.53	45	357	223
2	4-1/4	4-3/4	5-13/16	7-3/4	6-3/4	8-1/4	3-3/4	5	6	5-1/4	2.62	2.75	94	599	395
2-1/2	6-3/16	7	7-13/16	10-1/2	8-1/2	11-3/8	5-7/8	7-5/8	7	6	7.42	7.70	120	856	579
3	6-3/16	7	7-13/16	10-11/16	9-3/4	11-9/16	5-7/8	7-5/8	7-1/2	6-13/16	7.46	7.81	120	1416	974
4	7-5/8	7-1/2	8-1/4	12-1/16	10-1/4	12-3/4	6-3/4	6-3/4	9-1/16	7-1/2	12.35	12.48	336	2865	1952

1: Valve Lay Length  
 2: Torque required at valve maximum internal pressure rating, 5ft/sec. Flow velocity; due to adjustment differences during installation, actual valves may vary.  
 3: Gallons per minute at 1 psi pressure drop. Valves calculated from laying length, based on derivative of Hazen-Williams equation with surface roughness factor of C=150.

### Temperature Pressure Rating

System Operating Temperature °F (°C)			100 (38)	110 (43)	120 (49)	130 (54)	140 (60)	150 (66)	160 (71)	170 (77)	180 (82)	190 (88)	200 (93)	210 (99)
Valve Pressure Rating psi (MPa)	1/2" - 2"	PVC	235 (1.62)	211 (1.45)	150 (1.03)	75 (.52)	50 (.34)	-0- (-0-)	-0- (-0-)	-0- (-0-)	-0- (-0-)	-0- (-0-)	-0- (-0-)	-0- (-0-)
		CPVC	235 (1.62)	219 (1.51)	170 (1.17)	145 (1.00)	130 (.90)	110 (.76)	90 (.62)	80 (.55)	70 (.48)	60 (.41)	50 (.34)	-0- (-0-)
	2-1/2" - 4"	PVC	150 (1.03)	135 (.93)	110 (.76)	75 (.52)	50 (.34)	-0- (-0-)	-0- (-0-)	-0- (-0-)	-0- (-0-)	-0- (-0-)	-0- (-0-)	-0- (-0-)
		CPVC	150 (1.03)	140 (.97)	130 (.90)	120 (.83)	110 (.76)	100 (.70)	90 (.62)	80 (.55)	70 (.48)	60 (.41)	50 (.34)	-0- (-0-)

## Thermoplastic Valves Product Guide & Engineering Specifications

### True Union Ball Valve (Regular Style)



### Features – PVC, CPVC

This versatile, quarter-turn shutoff valve is well suited for industrial and chemical processing applications. Available in IPS Sizes 1/2" - 4" with socket, threaded or flanged end connectors. 6" Venturied valve (4" valve with 4 x 6 adapter) available with either socket or flanged end connection. Also available with metric 20mm - 110mm or 1/2" - 4" BSP threaded end connectors.

- Chemical & Corrosion Resistant PVC or CPVC Construction
- Schedule 80 Full-Bore Design
- Strong, Buttress Thread Union Nuts
- Fully Serviceable, Replaceable Components
- Spears® Safe-T-Blocked® Seal Carrier
- Self Adjusting PTFE Floating Seat Design
- EPDM or FKM O-rings
- High Impact Polypropylene Handle
- Spears® Safe-T-Shear® Stem Design
- Sizes 1/2" - 2" Pressure Rated to 235 psi @ 73°F, Sizes 2-1/2" - 6" and all flanged Pressure Rated to 150 psi @ 73°F
- EPDM valves NSF® Certified for Potable Water use
- Suitable for Vacuum Service
- Assembled with Silicone-Free, Water Soluble Lubricants
- Manufactured to ASTM F 1970

### Sample Engineering Specification

All thermoplastic ball valves shall be True Union type constructed from PVC Type I, ASTM D 1784 Cell Classification 12454 or CPVC Type IV, ASTM D 1784 Cell Classification 23447. All O-rings shall be EPDM or FKM. All valves shall have Safe-T-Shear® stem and double stop Polypropylene handle. All valve union nuts shall have Buttress threads. All seal carriers shall be Safe-T-Blocked®. All valve components shall be replaceable. All EPDM valves shall be certified by NSF International for use in potable water service. All 1/2" - 2" valves shall be pressure rated at 235 psi and all 2-1/2" - 6" and all flanged valves shall be pressure rated at 150 psi for water at 73°F, as manufactured by Spears® Manufacturing Company.

### Quick-View Valve Selection Chart

Valve Size	O-ring Material	PVC Part Number <sup>1</sup>			Pressure Rating
		Threaded	Socket	Flanged	
1/2	EPDM	2329-005	included	2323-005	235 psi Non-Shock Water @ 73°F  (Flanged 150 psi Non-Shock) Water @ 73°F
	FKM	2339-005	included	2333-005	
3/4	EPDM	2329-007	included	2323-007	
	FKM	2339-007	included	2333-007	
1	EPDM	2329-010	included	2323-010	
	FKM	2339-010	included	2333-010	
1-1/4	EPDM	2329-012	included	2323-012	
	FKM	2339-012	included	2333-012	
1-1/2	EPDM	2329-015	included	2323-015	
	FKM	2339-015	included	2333-015	
2	EPDM	2329-020	included	2323-020	
	FKM	2339-020	included	2333-020	
2-1/2	EPDM	2321-025	2322-025	2323-025	
	FKM	2331-025	2332-025	2333-025	
3	EPDM	2321-030	2322-030	2323-030	150 psi Non-Shock Water @ 73°F
	FKM	2331-030	2332-030	2333-030	
4	EPDM	2321-040	2322-040	2323-040	
	FKM	2331-040	2332-040	2333-040	
6 <sup>2</sup> venturied	EPDM	---	2322-060	2323-060	
	FKM	---	2332-060	2333-060	

1: For CPVC valves, add the letter "C" to part numbers listed (e.g., 2339-005C).

2: Consists of 4" True Union Ball Valve with two 4" x 6" Adapters.

### Optional Accessories\*

- Round Safety Handle
- Stem Extension Kit
- 2" Square / T-Style Operator Nut

\* See "BALL VALVE ACCESSORIES" section for details of individual products.





## Thermoplastic Valves Product Guide & Engineering Specifications

### True Union Ball Valve (Regular Style)

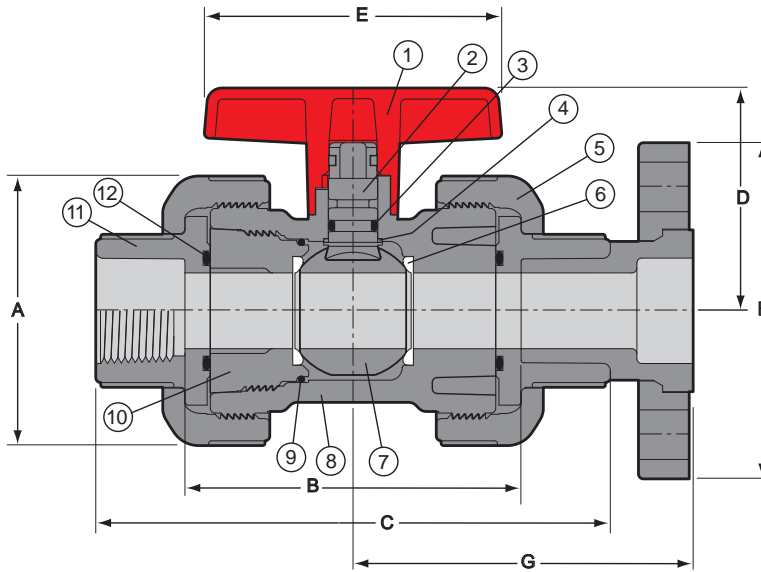

### Replacement Parts

No.	Component	Qty.	Material
1	Handle	1	PP
2	Stem	1	PVC/CPVC
3	Stem O-ring	1	EPDM/FKM
4	Stem Bearing*	1	PP
5	Union Nut	2	PVC/CPVC
6	Seat**	2	PTFE
7	Ball	1	PVC/CPVC
8	Body	1	PVC/CPVC
9	Carrier O-ring	1	EPDM/FKM
10	Seal Carrier	1	PVC/CPVC
11	End Connector	2	PVC/CPVC
12	End Connector O-ring	2	EPDM/FKM

\* Sizes 1-1/4" and larger.

\*\* Seat O-ring (not shown) on sizes 2-1/2" and larger.

### Dimensions, Weights, Operating Torque & Cv Values

Nominal Size	Dimension Reference (inches, ± 1/16)							Approx. Wt. (Lbs.)				Oper. <sup>2</sup> Torque (in.-lb.)	Cv <sup>4</sup> Values	
	A	B <sup>1</sup>	C	D	E	F	G	PVC		CPVC			Soc/Thd	Flanged
								Soc/Thd	Flanged	Soc/Thd	Flanged			
1/2	2-9/16	3-7/16	5-3/16	2-13/32	2-23/32	3-1/2	3-15/32	1.05	1.23	.95	1.14	20	25	18
3/4	3-1/32	4-1/16	6-3/16	2-5/8	3-3/16	3-7/8	4	1.44	1.64	1.50	1.73	30	51	36
1	3-13/32	4-5/16	6-9/16	2-13/16	3-23/32	4-1/4	4-5/16	1.91	2.22	2.08	2.43	40	97	67
1-1/4	3-11/16	4-1/2	7-1/16	2-31/32	4-1/8	4-5/8	4-19/32	2.38	2.78	2.52	2.91	60	204	142
1-1/2	4-3/8	5-5/16	8-1/32	3-9/32	4-15/32	5	5-9/32	3.63	4.00	3.82	4.26	80	285	201
2	5-3/16	5-13/16	8-13/16	4-13/32	5-1/4	6	5-23/32	5.40	6.14	5.70	6.54	90	540	381
2-1/2	7-7/16	8-3/8	11-7/8	4-29/32	9-7/8	7	7-3/16	12.87	14.26	13.44	15.85	300	712	512
3	7-7/16	8-3/16	11-15/16	4-29/32	9-7/8	7-1/2	7-11/32	13.24	15.67	13.85	16.96	300	1294	925
4	8-15/16	8-11/16	13-3/16	5-19/32	10-13/16	9-1/16	8-5/32	19.58	24.32	20.49	25.83	400	2629	1868
6 Socket <sup>3</sup>	8-15/16	19-5/8	26-1/16	6-3/4	10-13/16	11-1/4	14-11/16	22.66	30.98	26.11	34.78	400	N/A	N/A
6 Flanged <sup>3</sup>	11-3/16	29-3/8	N/A	6-3/4	10-13/16	11-1/4	14-11/16	N/A	N/A	N/A	N/A	400	N/A	N/A

1: Valve Lay Lengths.

2: Torque required at valve maximum internal pressure rating, 5 ft./sec. flow velocity.

3: Consists of 4" True Union Ball Valve with two 4" x 6" Adapters.

4: Gallons per minute at 1 psi pressure drop. Values calculated from valve laying length, based on derivative of Hazen-Williams equation with surface roughness factor of C=150.  
Cv Values for 6" venturied flange and socket valves are not available.

### Temperature Pressure Rating

System Operating Temperature °F (°C)		100 (38)	110 (43)	120 (49)	130 (54)	140 (60)	150 (66)	160 (71)	170 (77)	180 (82)	190 (88)	200 (93)	210 (99)	
Valve Pressure Rating psi (MPa)	1/2" - 2"	PVC	235 (1.62)	211 (1.45)	150 (1.03)	75 (.52)	50 (.34)	-0- (-0-)	-0- (-0-)	-0- (-0-)	-0- (-0-)	-0- (-0-)	-0- (-0-)	
		CPVC	235 (1.62)	219 (1.51)	170 (1.17)	145 (1.00)	130 (.90)	110 (.76)	90 (.62)	80 (.55)	70 (.48)	60 (.41)	50 (.34)	-0- (-0-)
	2-1/2" - 6"	PVC	150 (1.03)	135 (.93)	110 (.76)	75 (.52)	50 (.34)	-0- (-0-)	-0- (-0-)	-0- (-0-)	-0- (-0-)	-0- (-0-)	-0- (-0-)	-0- (-0-)
		CPVC	150 (1.03)	140 (.97)	130 (.90)	120 (.83)	110 (.76)	100 (.70)	90 (.62)	80 (.55)	70 (.48)	60 (.41)	50 (.34)	-0- (-0-)

**NOTE:** Flanged Valves have a base pressure rating of 150 psi.



### Features – PVC, CPVC

Flow tested design provides quick response with positive seal for prevention of system back flow in industrial and chemical processing applications. Available in IPS Sizes 1/2"- 4" with socket, threaded or flanged end connectors. 6" Venturied valve (4" valve with 4 x 6 adapters) available with either socket or flanged end connection. Also available with metric 20mm - 110mm or 1/2" - 4" BSP thread end connectors. **Note:** Seal carrier is **NOT** blocked (for Safe-T-Blocked® seal carrier design, see True Union 2000 Industrial Ball Check Valve).

### Sample Engineering Specification

All thermoplastic check valves shall be True Union Ball type constructed from PVC Type I, ASTM D 1784 Cell Classification 12454 or CPVC Type IV, ASTM D 1784 Cell Classification 23447. All O-rings shall be EPDM or FKM. All valve union nuts shall have Buttress threads. All valve components shall be replaceable. All EPDM valves shall be certified by NSF International for use in potable water service. All 1/2" - 2" valves shall be pressure rated at 235 psi and all 2-1/2" - 6" and all flanged valves shall be pressure rated at 150 psi for water at 73°F, as manufactured by Spears® Manufacturing Company.

- Chemical & Corrosion Resistant PVC or CPVC Construction
- Strong, Buttress Thread Union Nuts
- Fully Serviceable, Replaceable Components
- Uses Standard O-ring Seat
- EPDM or FKM O-rings
- Sizes 1/2" - 2" Pressure Rated to 235 psi @ 73°F, Sizes 2-1/2" - 6" and all Flanged Pressure Rated to 150 psi @ 73°F
- Suitable for Either Horizontal or Vertical Installations
- EPDM valves NSF® Certified for Potable Water use
- Suitable for Vacuum Service
- Assembled with Silicone-Free, Water Soluble Lubricants
- Manufactured to ASTM F 1970

### Quick-View Valve Selection Chart

Valve Size	O-ring Material	PVC Part Number <sup>1</sup>			Pressure Rating
		Threaded	Socket	Flanged	
1/2	EPDM	2229-005	included	2223-005	235 psi Non-Shock Water @ 73°F  (Flanged 150 psi Non-Shock) Water @ 73°F
	FKM	2239-005	included	2233-005	
3/4	EPDM	2229-007	included	2223-007	
	FKM	2239-007	included	2233-007	
1	EPDM	2229-010	included	2223-010	
	FKM	2239-010	included	2233-010	
1-1/4	EPDM	2229-012	included	2223-012	
	FKM	2239-012	included	2233-012	
1-1/2	EPDM	2229-015	included	2223-015	
	FKM	2239-015	included	2233-015	
2	EPDM	2229-020	included	2223-020	
	FKM	2239-020	included	2233-020	
2-1/2	EPDM	2221-025	2222-025	2223-025	150 psi Non-Shock Water @ 73°F
	FKM	2231-025	2232-025	2233-025	
3	EPDM	2221-030	2222-030	2223-030	
	FKM	2231-030	2232-030	2233-030	
4	EPDM	2221-040	2222-040	2223-040	
	FKM	2231-040	2232-040	2233-040	
6 <sup>2</sup> venturied	EPDM	---	2222-060	2223-060	
	FKM	---	2232-060	2233-060	

1: For CPVC valves, add the letter "C" to part numbers listed (e.g., 2239-005C).  
 2: Consists of 4" True Union Ball Valve with two 4" x 6" Adapters.

### Ball Check Foot Valves

Spears® Ball Check Valves easily convert to foot valves utilizing optional Foot Valve Screen adapters found in Ball Valve Accessories section.





## Thermoplastic Valves Product Guide & Engineering Specifications

### True Union Ball Check Valve (Regular Style)

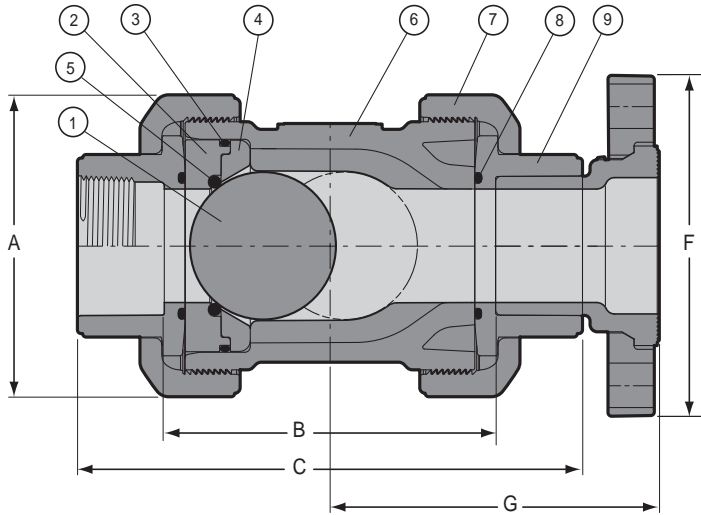

### Replacement Parts

No.	Component	Qty.	Material
1	Ball	1	PVC/CPVC
2	Seal Carrier	1	PVC/CPVC
3	Carrier O-ring	1	EPDM/FKM
4	Seat Plate	1	PVC/CPVC
5	Seat O-ring	1	EPDM/FKM
6	Body	1	PVC/CPVC
7	Union Nut	2	PVC/CPVC
8	End Connector O-ring	2	EPDM/FKM
9	End Connector	2	PVC/CPVC

### Dimensions, Weights, Cv Values & Horizontal Closing Requirements

Nominal Size	Dimension Reference (inches, ± 1/16)					Approx. Wt. (Lbs.)		Cv <sup>3</sup> Values		Horizontal Closing	
	A	B <sup>1</sup>	C	F	G	PVC	CPVC	Threaded/Socket	Flanged	Feet of Head (water)	GPM (minimum)
1/2	2-9/16	3-5/16	5-1/8	3-1/2	3-7/16	.56	.61	11	10	1.6	.10
3/4	3	4	6-1/8	3-7/8	3-15/16	.91	.99	18	17	1.6	.10
1	3-7/16	4-1/4	6-1/2	4-1/4	4-3/8	1.20	1.30	32	30	1.6	.25
1-1/4	3-11/16	4-1/2	7	4-5/8	4-9/16	1.50	1.60	58	55	1.6	.40
1-1/2	4-3/8	5-5/16	8-1/16	5	5-1/4	2.50	2.70	94	89	1.6	.75
2	5-1/8	5-3/4	8-3/4	6	5-5/8	3.70	4.00	153	146	1.6	.75
2-1/2	7-3/8	8-5/16	11-7/8	7	7-1/4	11.10	12.21	159	155	1.0	1.50
3	7-3/8	8-1/8	11-7/8	7-1/2	7-1/2	10.84	11.91	378	361	1.0	4.00
4	8-15/16	8-1/4	12-15/16	9-1/16	8-1/8	17.60	19.36	551	537	1.0	5.50
6 Socket <sup>2</sup>	8-15/16	19-5/8	26-1/16	N/A	N/A	22.45	27.61	N/A	N/A	N/A	N/A
6 Flanged <sup>2</sup>	11-3/16	29-3/8	N/A	11-1/4	14-3/4	31.21	37.07	N/A	N/A	N/A	N/A

- 1: Valve Lay Length
- 2: Consists of 4" True Union Ball Check Valve with two 4" x 6" Adapters.
- 3: Gallons per minute at 1 psi pressure drop.
- Cv Values for 6" venturied flange and socket valves are not available.

### Temperature Pressure Rating

System Operating Temperature °F (°C)		100 (38)	110 (43)	120 (49)	130 (54)	140 (60)	150 (66)	160 (71)	170 (77)	180 (82)	190 (88)	200 (93)	210 (99)
Valve Pressure Rating (MPa)	1/2" - 2"	PVC	235 (1.62)	211 (1.45)	150 (1.03)	75 (.52)	50 (.34)	-0- (-0-)	-0- (-0-)	-0- (-0-)	-0- (-0-)	-0- (-0-)	-0- (-0-)
		CPVC	235 (1.62)	219 (1.51)	170 (1.17)	145 (1.00)	130 (.90)	110 (.76)	90 (.62)	80 (.55)	70 (.48)	60 (.41)	50 (.34)
Valve Pressure Rating (MPa)	2-1/2" - 6"	PVC	150 (1.03)	135 (.93)	110 (.76)	75 (.52)	50 (.34)	-0- (-0-)	-0- (-0-)	-0- (-0-)	-0- (-0-)	-0- (-0-)	-0- (-0-)
		CPVC	150 (1.03)	140 (.97)	130 (.90)	120 (.83)	110 (.76)	100 (.70)	90 (.62)	80 (.55)	70 (.48)	60 (.41)	50 (.34)

**NOTE:** Flanged Valves have a base pressure rating of 150 psi.

**General Installation Information:** Ball check valves may be installed in either horizontal or vertical position. A minimum of ten (10) pipe diameters distance maintained from any pump or other source of turbulence. Ball Check valves **MUST** be installed with the valves **FLOW** arrow pointing in the direction of flow.



### Features – PVC, CPVC

Economical, low profile quarter-turn shutoff valve is excellent for general purpose and many O.E.M applications. PVC and CPVC valves are available in IPS sizes 1/2" through 2" with socket and regular thread.

- Industrial Grade, Maintenance-Free Sealed Unit
- New Actuator-Ready Body – Accepts Spears® Improved Mini-Mount Actuator Mounting Kits
- New Double O-ring Stem Seal
- Spears® Safe-T-Shear Stem
- PTFE Self Adjusting Floating Seats
- EPDM or FKM O-ring Seals
- Full 235 psi Pressure Rating @ 73°F
- EPDM valves NSF® Certified for Use with Potable Water
- Suitable for Vacuum Service
- Produced in ASTM IPS sizes 1/2" - 2" with Socket or Threaded End Connectors.

### Sample Engineering Specification

All thermoplastic ball valves shall be 2000 Compact sealed unit type manufactured to ASTM F 1970 and constructed from PVC Type I, ASTM D 1784 Cell Classification 12454 or CPVC Type IV, ASTM D 1784 Cell Classification 23447. All O-rings shall be EPDM or FKM. All valves shall have Safe-T-Shear® stem with O-ring stem seal. All handles shall be polypropylene. All EPDM valves shall be certified by NSF International for use with potable water. All 1/2" - 2" valves shall be pressure rated to 235 psi, for water @ 73°F, as manufactured by Spears® Manufacturing Company.

### Optional Accessories\*

- Round Safety Handles
- Stem Extension Kits
- Square Operator Nuts
- Multi Mount Valve/Actuation Mounting Kits
- Mini-Mount Actuation Mounting Kits

\* See "BALL VALVE ACCESSORIES" section for details of individual products.



### Quick-View Valve Selection Chart

Valve Size	O-ring Material	PVC Part Number <sup>1</sup>			Pressure Rating
		Socket	Threaded	Flanged	
1/2	EPDM	6622-005	6621-005	6623-005	235 psi Non-Shock Water @73°F
	FKM	6632-005	6631-005	6633-005	
3/4	EPDM	6622-007	6621-007	6623-007	
	FKM	6632-007	6631-007	6633-007	
1	EPDM	6622-010	6621-010	6623-010	
	FKM	6632-010	6631-010	6633-010	
1-1/4	EPDM	6622-012	6621-012	6623-012	
	FKM	6632-012	6631-012	6633-012	
1-1/2	EPDM	6622-015	6621-015	6623-015	
	FKM	6632-015	6631-015	6633-015	
2	EPDM	6622-020	6621-020	6623-020	
	FKM	6632-020	6631-020	6633-020	

1: For CPVC Valves, add the letter "C" to part numbers listed. (e.g., 6622-005C)



## Thermoplastic Valves Product Guide & Engineering Specifications

### Compact 2000 Ball Valves

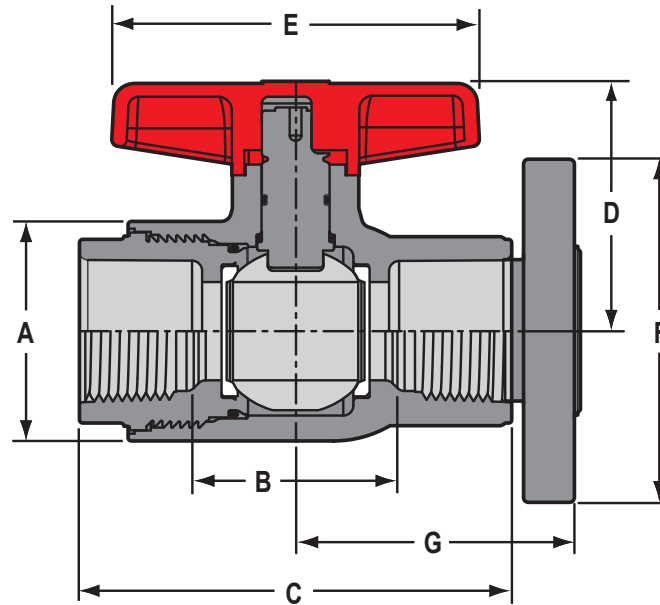

### Dimensions, Weights, Operating Torque & Cv Values

Nominal Size	Dimension Reference (inches, ± 1/16)								Approx. Wt. (Lbs.)		Oper. <sup>2</sup> Torque (in.-lb.)	Cv <sup>3</sup> Values
	A	B <sup>1</sup>		C	D	E	F	G	PVC	CPVC		
		Socket	Threaded									
1/2	1-7/16	1-1/4	1-5/8	3-1/16	1-5/8	1-5/8	3-1/2	2-11/32	.18	.20	10	42
3/4	1-13/16	1-1/2	2-1/16	3-9/16	2	2	3-7/8	2-5/8	.29	.31	20	87
1	2-1/16	1-3/4	2-3/16	4	2-5/16	2-5/16	4-1/4	2-29/32	.44	.46	25	157
1-1/4	2-5/8	2-1/6	2-3/4	4-5/8	2-13/16	2-13/16	4-5/8	3-9/32	.68	.70	30	311
1-1/2	3	2-1/2	3-3/8	5-5/16	3-1/16	3-1/16	5	3-27/32	.99	1.03	50	429
2	3-5/8	3	4	6	3-3/4	3-3/4	5-7/8	4-1/4	1.64	1.70	90	768

1: Valve Lay Length

2: Torque required at valve maximum internal pressure rating, 5ft/sec. Flow velocity.

3: Gallons per minute at 1 psi pressure drop. Valves calculated from laying length, based on derivative of Hazen-Williams equation with surface roughness factor of C=150.

### Temperature Pressure Rating

System Operating Temperature °F (°C)		100 (38)	110 (43)	120 (49)	130 (54)	140 (60)	150 (66)	160 (71)	170 (77)	180 (82)	190 (88)	200 (93)	210 (99)	
Valve Pressure Rating psi (MPa)	1/2" - 2"	PVC	235 (1.62)	211 (1.45)	150 (1.03)	75 (.52)	50 (.34)	-0- (-0-)	-0- (-0-)	-0- (-0-)	-0- (-0-)	-0- (-0-)	-0- (-0-)	
		CPVC	235 (1.62)	219 (1.51)	170 (1.17)	145 (1.00)	130 (.90)	110 (.76)	90 (.62)	80 (.55)	70 (.48)	60 (.41)	50 (.34)	-0- (-0-)
	Flanged	PVC	150 (1.03)	135 (.93)	110 (.76)	75 (.52)	50 (.34)	-0- (-0-)	-0- (-0-)	-0- (-0-)	-0- (-0-)	-0- (-0-)	-0- (-0-)	-0- (-0-)
		CPVC	150 (1.03)	140 (.97)	130 (.90)	120 (.83)	110 (.76)	100 (.70)	90 (.62)	80 (.55)	70 (.48)	60 (.41)	50 (.34)	-0- (-0-)

## Compact Ball Valves



### Features – PVC, CPVC

This industrial grade, quarter turn shutoff valve is popular where maintenance-free installations are desired for a variety of chemical processing, industrial and OEM applications. IPS Sizes 1/2" - 4" available with socket, threaded or flanged end connectors, 6" size available with socket or flanged end connectors. 6" valve uses high-efficiency lever style handle for easier operation.

- Chemical & Corrosion Resistant PVC or CPVC Construction
- Maintenance-Free Sealed Unit
- Schedule 80 Full-Bore Design
- High Impact Polypropylene Handle
- Spears® Single O-ring Safe-T-Shear® Stem Design
- EPDM or FKM O-rings
- Self Adjusting PTFE Floating Seat Design
- Sizes 1/2" - 2" Pressure Rated to 235 psi @ 73°F, Sizes 3" - 6" and all Flanged Pressure Rated to 150 psi @ 73°F
- EPDM valves NSF® Certified for Potable Water use
- Suitable for Vacuum Service
- Assembled with Silicone-Free, Water Soluble Lubricant
- Manufactured to ASTM F 1970

**Note:** Valve size 6" uses Lever Handle (not shown)

### Sample Engineering Specification

All thermoplastic ball valves shall be Compact sealed unit type constructed from PVC Type I, ASTM D 1784 Cell Classification 12454 or CPVC Type IV, Cell Classification 23447. All O-rings shall be EPDM or FKM. All valves shall have Safe-T-Shear® stem and Polypropylene handle. All EPDM valves shall be certified by NSF International for use in potable water service. All 1/2" - 2" valves shall be pressure rated at 235 psi, all 3" - 6" and all flanged valves shall be pressure rated at 150 psi for water at 73°F, as manufactured by Spears® Manufacturing Company.

### Quick-View Valve Selection Chart

Valve Size	O-ring Material	PVC Part Numbers <sup>1</sup>			Pressure Rating	
		Socket	Threaded	Flanged		
1/2	EPDM	2122-005	2121-005	2123-005	235 psi Non-Shock Water @ 73°F	
	FKM	2132-005	2131-005	2133-005		
3/4	EPDM	2122-007	2121-007	2123-007		
	FKM	2132-007	2131-007	2133-007		
1	EPDM	2122-010	2121-010	2123-010		
	FKM	2132-010	2131-010	2133-010		
1-1/4	EPDM	2122-012	2121-012	2123-012		(Flanged 150 psi Non-Shock) Water @ 73°F
	FKM	2132-012	2131-012	2133-012		
1-1/2	EPDM	2122-015	2121-015	2123-015		
	FKM	2132-015	2131-015	2133-015		
2	EPDM	2122-020	2121-020	2123-020		
	FKM	2132-020	2131-020	2133-020		
3	EPDM	2122-030	2121-030	2123-030	150 psi Non-Shock Water @ 73°F	
	FKM	2132-030	2131-030	2133-030		
4	EPDM	2122-040	2121-040	2123-040		
	FKM	2132-040	2131-040	2133-040		
6	EPDM	2122-060	---	2123-060		
	FKM	2132-060	---	2133-060		

1: For CPVC valves, add the letter "C" to the part numbers listed (e.g., 2131-005C).

### Optional Accessories\*

- Round Safety Handle
- Stem Extension Kit
- Mini-Mount Actuation Mounting Kit
- 2" Square/T-Style Operator Nut

\*See "BALL VALVE ACCESSORIES" section for details of individual products.





## Compact Ball Valves

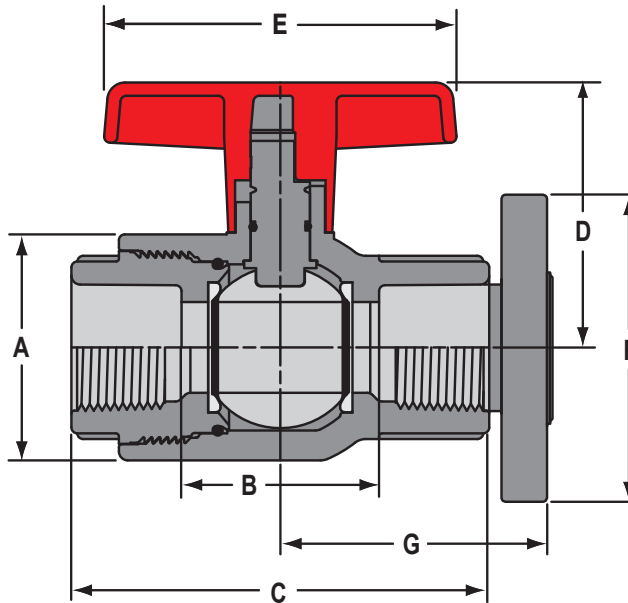

### Dimensions, Weights, Operating Torque & Cv Values

Nominal Size	Dimension Reference (inches, ± 1/16)								Approx. Wt. (Lbs.)		Oper. <sup>2</sup> Torque (in.-lb.)	Cv <sup>3</sup> Values	
	A	B <sup>1</sup>		C	D	E <sup>4</sup>	F	G	PVC	CPVC		Soc/Thd	Flanged
		Socket	Threaded										
1/2	1-11/16	1-5/8	1-7/8	3-3/8	2-5/16	2-3/4	3-1/2	2-17/32	.31	.32	20	36	20
3/4	2-1/8	1-15/16	2-7/16	4-1/16	2-11/16	3-1/4	3-7/8	2-27/32	.49	.52	30	74	42
1	2-7/16	2-1/16	2-3/8	4-7/16	2-7/8	3-3/4	4-1/4	3-1/16	.64	.69	40	141	80
1-1/4	2-13/16	2-3/8	3	4-15/16	3-5/16	4-1/8	4-5/8	3-13/32	.93	.98	60	284	163
1-1/2	3-1/4	2-13/16	3-1/2	5-5/8	3-11/16	4-1/2	5	4	1.39	1.45	80	402	229
2	4-1/16	3-3/8	4-7/16	6-1/2	4-3/8	5-1/4	5-7/8	4-13/32	2.33	2.45	90	706	429
3	5-5/16	4-9/16	5-1/2	8-5/16	5-1/2	7-21/32	7-1/2	5-7/16	4.49	5.02	300	1660	1079
4	7-3/8	6-3/16	7-3/16	10-5/32	6-5/8	10-27/32	9-1/16	6-7/8	9.50	10.24	400	3104	2028
6 <sup>4</sup>	10-3/16	8	10-3/4	14-1/8	8-1/16	14-5/16	11-1/4	8-21/32	21.48	23.41	900	7942	5268

1: Valve Lay Length

2: Torque required at valve maximum internal pressure rating, 5 ft./sec. flow velocity.

3: Gallons per minutes at 1 psi pressure loss. Values calculated from valve laying length, based on derivative of Hazen-Williams equation with surface roughness factor of C=150.

4: 6" valve has lever handle, dimension is from valve centerline (not illustrated)

### Temperature Pressure Rating

System Operating Temperature °F (°C)		100 (38)	110 (43)	120 (49)	130 (54)	140 (60)	150 (66)	160 (71)	170 (77)	180 (82)	190 (88)	200 (93)	210 (99)	
Valve Pressure Rating psi (MPa)	1/2" - 2"	PVC	235 (1.62)	211 (1.45)	150 (1.03)	75 (.52)	50 (.34)	-0- (-0-)	-0- (-0-)	-0- (-0-)	-0- (-0-)	-0- (-0-)	-0- (-0-)	
		CPVC	235 (1.62)	219 (1.51)	170 (1.17)	145 (1.00)	130 (.90)	110 (.76)	90 (.62)	80 (.55)	70 (.48)	60 (.41)	50 (.34)	-0- (-0-)
	3" - 6" and Flanged	PVC	150 (1.03)	135 (.93)	110 (.76)	75 (.52)	50 (.34)	-0- (-0-)	-0- (-0-)	-0- (-0-)	-0- (-0-)	-0- (-0-)	-0- (-0-)	-0- (-0-)
		CPVC	150 (1.03)	140 (.97)	130 (.90)	120 (.83)	110 (.76)	100 (.70)	90 (.62)	80 (.55)	70 (.48)	60 (.41)	50 (.34)	-0- (-0-)



### Features - PVC White, PVC Gray & CPVC

A high quality, economical quarter-turn shutoff valve designed for irrigation, pool and spa, and general purpose applications. IPS sizes 1/2" - 2" available in PVC White, PVC Gray or CPVC with socket or threaded end connectors. Sizes 3" - 4" available in PVC White with socket or threaded end connectors. 6" size available in PVC White with socket end connectors and high-efficiency lever style handle for easier operation.

- Chemical & Corrosion Resistant PVC or CPVC Construction
- Economical Sealed Unit
- Schedule 80 Full-Bore Design
- High Impact Polypropylene Handle
- Spears® Single O-ring Safe-T-Shear® Stem Design
- EPDM O-rings
- PTFE/HDPE Floating Seat Design
- Sizes 1/2" - 6" Pressure Rated to 150 psi @ 73°F
- NSF® Certified for Potable Water use
- Assembled with Silicone-Free, Water Soluble lubricant

**Note:** Valve sizes 2-1/2", 3", 4" and 6" are not available in CPVC. Refer to Compact Ball Valve  
Valve size 6" uses Lever Handle (not shown)

### Sample Engineering Specification

All thermoplastic ball valves shall be Utility sealed unit type constructed from PVC Type I, ASTM D 1784 Cell Classification 12454 or CPVC Type IV, ASTM D 1784 Cell Classification 23447. All O-rings shall be EPDM. All valves shall have Safe-T-Shear® stem and Polypropylene handle. All valves shall be certified by NSF International for use in potable water service. All valves shall be pressure rated at 150 psi for water at 73°F, as manufactured by Spears® Manufacturing Company.

### Quick-View Valve Selection Chart

Valve Size	O-ring Material	PVC Part Number <sup>1, 2</sup>		Pressure Rating
		Socket	Threaded	
1/2	EPDM	2622-005	2621-005	150 psi Non-Shock Water @ 73°F
3/4	EPDM	2622-007	2621-007	
1	EPDM	2622-010	2621-010	
1-1/4	EPDM	2622-012	2621-012	
1-1/2	EPDM	2622-015	2621-015	
2	EPDM	2622-020	2621-020	
2-1/2	EPDM	2622-025	2621-025	
3	EPDM	2622-030	2621-030	
4	EPDM	2622-040	2621-040	
6	EPDM	2622-060	---	

1: For CPVC valves, add the letter "C" to part numbers listed (e.g., 2621-005C).  
2: For PVC Gray, add the letter "G" to part numbers listed (e.g. 2621-005G).





## Thermoplastic Valves Product Guide & Engineering Specifications

### Utility Ball Valves

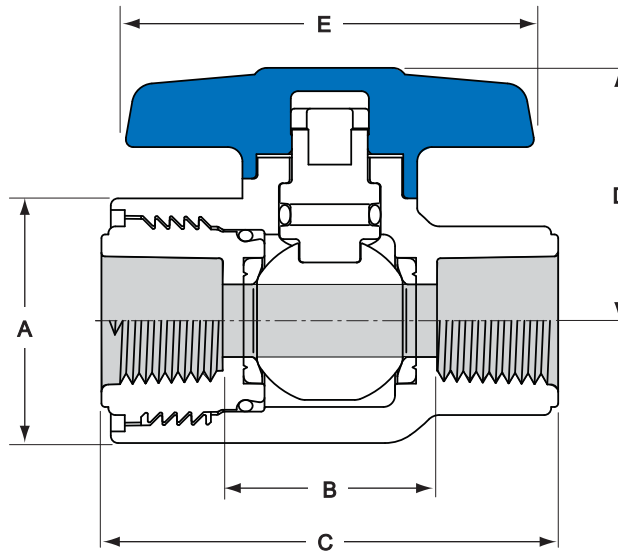

### Dimensions, Weights & C<sub>v</sub> Values

Nominal Size	Dimension Reference (inches, ± 1/16)						Approx. Wt. (Lbs.)		C <sub>v</sub> <sup>2</sup> Values
	A	B <sup>1</sup>		C	D	E <sup>3</sup>	PVC	CPVC	
		Socket	Threaded						
1/2	1-7/16	1-7/32	1-7/32	2-21/32	1-11/16	2-3/4	.16	.17	46
3/4	1-25/32	1-7/16	1-7/16	2-29/32	2-1/32	3-1/4	.25	.27	91
1	2-1/16	1-19/32	1-19/32	3-3/8	2-13/32	3-17/32	.34	.36	160
1-1/4	2-9/16	1-31/32	1-31/32	3-7/8	2-27/32	3-25/32	.57	.60	306
1-1/2	2-31/32	2-15/32	2-25/32	4-11/16	3-5/32	3-5/32	.88	.90	429
2	3-9/16	2-13/16	3-3/16	5-5/32	3-7/8	4-9/32	1.34	1.34	755
2-1/2	4-5/16	3-17/32	4-7/16	7-1/16	4-3/16	5-1/32	2.31	N/A	1126
3	5-11/32	4-5/32	5-1/8	7-15/16	5-9/16	7-3/4	4.78	N/A	1660
4	6-11/16	5-1/8	6-7/32	9-3/16	6-5/32	9-5/32	8.00	N/A	3129
6 <sup>3</sup>	10-3/16	8-3/32	---	14-3/16	8-5/32	14-3/32	23.24	N/A	7942

1: Valve Lay Length

2: Gallons per minute at 1 psi pressure drop. Values calculated from valve laying length, based on derivative of Hazen-Williams equation with surface roughness factor of C=150.

3: 6" valve has lever handle, dimension is from valve stem centerline (not illustrated)

### Temperature Pressure Rating

System Operating Temperature °F (°C)		73 (23)	100 (38)	110 (43)	120 (49)	130 (54)	140 (60)	150 (66)	160 (71)	170 (77)	180 (82)	190 (88)
Valve Pressure Rating psi (MPa)	PVC	150 (1.03)	93 (.64)	75 (.52)	60 (.41)	45 (.31)	33 (.23)	-0- (-0-)	-0- (-0-)	-0- (-0-)	-0- (-0-)	-0- (-0-)
	CPVC	150 (1.03)	123 (.85)	110 (.76)	98 (.68)	86 (.58)	75 (.52)	68 (.47)	60 (.41)	48 (.33)	38 (.26)	-0- (-0-)

## CWV Ball Valves



### Features - PVC White

A high quality, economical quarter-turn shutoff valve designed for irrigation, pool and spa, and general purpose applications. IPS sizes 1/2" - 2" available in PVC White.

- Chemical & Corrosion Resistant PVC Construction
- Economical Sealed Unit
- High Impact, U.V. Resistant Polypropylene Handle
- Spears® Single O-ring Safe-T-Shear® Stem Design
- EPDM O-rings
- Sizes 1/2" - 2" Pressure Rated to 125 psi @ 73°F
- NSF® Certified for Potable Water use
- Assembled with Silicone-Free, Water Soluble lubricant



### Sample Engineering Specification

All thermoplastic ball valves shall be CWV sealed unit type constructed from PVC Type I, ASTM D 1784 Cell Classification 12454. All O-rings shall be EPDM. All valves shall have Safe-T-Shear® stem and Polypropylene handle. All valves shall be certified by NSF International for use in potable water service. All valves shall be pressure rated at 125 psi for water at 73°F, as manufactured by Spears® Manufacturing Company.

### Quick-View Valve Selection Chart

Valve Size	O-ring Material	PVC Part Number		Pressure Rating
		Socket	Threaded	
1/2	EPDM	8722-005	8721-005	125 psi Non-Shock Water @ 73°F
3/4	EPDM	8722-007	8721-007	
1	EPDM	8722-010	8721-010	
1-1/4	EPDM	8722-012	8721-012	
1-1/2	EPDM	8722-015	8721-015	
2	EPDM	8722-020	8721-020	



## CWV Ball Valves

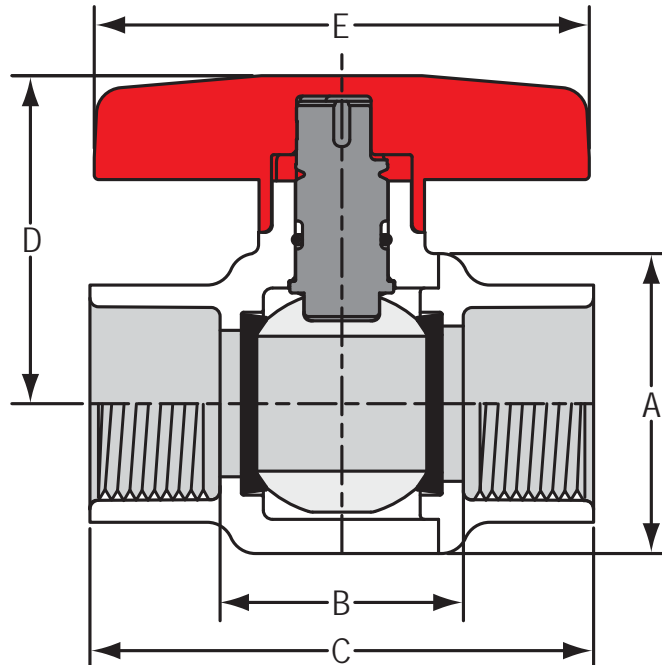

### Dimensions

Size	A	B		C	D	E
		Socket	Threaded			
1/2	1-5/16	1-7/32	1-7/32	2-5/8	1-9/16	2-5/8
3/4	1-5/8	1-15/32	1-7/16	2-15/16	1-15/16	2-7/8
1	1-7/8	1-5/8	1-5/8	3-7/16	2-1/4	3-3/8
1-1/4	2-3/8	2	2	3-7/8	2-3/4	3-7/8
1-1/2	2-3/4	2-7/16	2-3/4	4-5/8	3-1/8	4-1/2
2	3-11/32	2-25/32	2-25/32	5-1/8	3-23/32	4-31/32

### Temperature Pressure Rating

System Operating Temperature °F (°C)		73 (23)	100 (38)	110 (43)	120 (49)	130 (54)	140 (60)	150 (66)	160 (71)	170 (77)	180 (82)	190 (88)
Valve Pressure Rating psi (MPa)	PVC	125 (.86)	78 (.54)	63 (.45)	50 (.35)	38 (.26)	28 (.19)	-0- (-0-)	-0- (-0-)	-0- (-0-)	-0- (-0-)	-0- (-0-)

## Single Entry Ball Valves



### Features – PVC Gray & PVC White

This quarter-turn shutoff valve is widely chosen for industrial and chemical processing, turf and irrigation, plus pool and spa applications. Available in PVC Gray or PVC White, IPS Sizes 1/2" - 4" with socket or threaded end connectors. **Note:** Seal carrier is **NOT** blocked (see True Union 2000 Valves).

- Chemical & Corrosion Resistant PVC Gray or PVC White Construction
- Schedule 80 Full-Bore Design
- Strong, Buttress Thread Union Nut
- High Impact Polypropylene Handle
- Spears® Single O-ring Safe-T-Shear® Stem Design
- Buna-N, EPDM or FKM O-rings
- Self Adjusting PTFE Floating Seat Design
- Fully Serviceable, Replaceable Components
- Sizes 1/2" - 2" Pressure Rated to 235 psi @ 73°F, Sizes 3" - 4" Pressure Rated to 150 psi @ 73°F
- Valves with EPDM O-rings NSF® Certified for Potable Water use
- Suitable for Vacuum Service
- Assembled with Silicone-Free, Water Soluble Lubricant
- Manufactured to ASTM F 1970

### Sample Engineering Specification

All thermoplastic ball valves shall be Single Entry type constructed from PVC Type I, ASTM D 1784 Cell Classification 12454. All O-rings shall be Buna-N, EPDM or FKM. All valves shall have Safe-T-Shear® stem and double stop Polypropylene handle. All valve union nuts shall have Buttress threads. All valve components shall be replaceable. All EPDM valves shall be certified by NSF International for use in potable water service. All 1/2" - 2" valves shall be pressure rated at 235 psi and all 3" - 4" valves shall be pressure rated at 150 psi for water at 73°F, as manufactured by Spears® Manufacturing Company.

### Quick-View Valve Selection Chart

Valve Size	O-ring Material	PVC Gray Part Numbers <sup>1</sup>		Pressure Rating
		Socket	Threaded	
1/2	Buna-N	2412-005G	2411-005G	235 psi Non-Shock Water @ 73°F
	EPDM	2422-005G	2421-005G	
	FKM	2432-005G	2431-005G	
3/4	Buna-N	2412-007G	2411-007G	
	EPDM	2422-007G	2421-007G	
	FKM	2432-007G	2431-007G	
1	Buna-N	2412-010G	2411-010G	
	EPDM	2422-010G	2421-010G	
	FKM	2432-010G	2431-010G	
1-1/4	Buna-N	2412-012G	2411-012G	
	EPDM	2422-012G	2421-012G	
	FKM	2432-012G	2431-012G	
1-1/2	Buna-N	2412-015G	2411-015G	
	EPDM	2422-015G	2421-015G	
	FKM	2432-015G	2431-015G	
2	Buna-N	2412-020G	2411-020G	
	EPDM	2422-020G	2421-020G	
	FKM	2432-020G	2431-020G	
3	Buna-N	2412-030G	2411-030G	150 psi Non-Shock Water @ 73°F
	EPDM	2422-030G	2421-030G	
	FKM	2432-030G	2431-030G	
4	Buna-N	2412-040G	2411-040G	
	EPDM	2422-040G	2421-040G	
	FKM	2432-040G	2431-040G	

1: For PVC White valves, replace the letter "G" with the letter "W" at the end of the part number listed (e.g., 2421-005W).

### Optional Accessories\*

- Round Safety Handle
- Stem Extension Kit
- 2" Square / T-Style Operator Nut

\*See "**BALL VALVE ACCESSORIES**" section for details of individual products.





## Thermoplastic Valves Product Guide & Engineering Specifications

### Single Entry Ball Valves

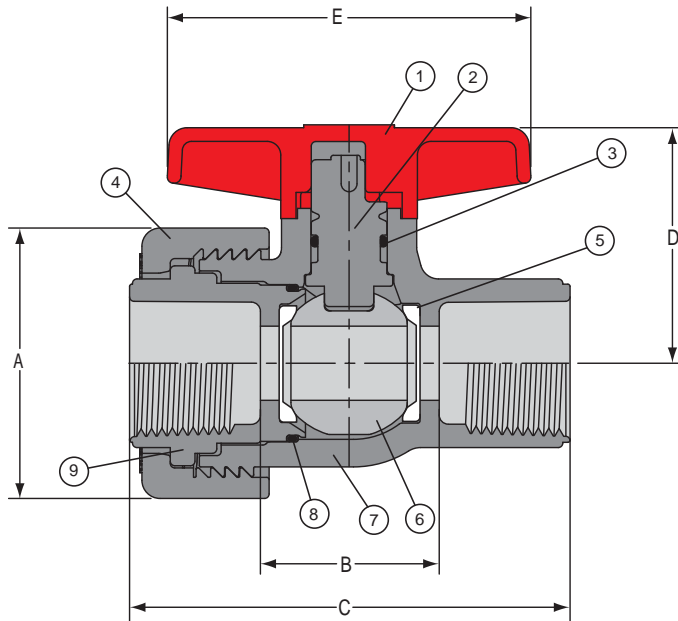

### Replacement Parts

No.	Component	Qty.	Material
1	Handle	1	PP
2	Stem	1	PVC
3	Stem O-ring	1	Buna-N/EPDM/FKM
4	Union Nut	1	PVC
5	Seat	2	PTFE
6	Ball	1	PVC
7	Body	1	PVC
8	Carrier O-ring	1	Buna-N/EPDM/FKM
9	End Connector	1	PVC

Seat O-rings (not shown) on sizes 3" and larger.

### Dimensions, Weights, Operating Torque & C<sub>v</sub> Values

Nominal Size	Dimension Reference (inches, ± 1/16)						Approx. Wt. (Lbs.)	Oper. <sup>2</sup> Torque (in.-lb.)	C <sub>v</sub> <sup>3</sup> Values
	A	B <sup>1</sup>		C	D	E			
		Socket	Threaded						
1/2	1-15/16	1-1/4	1-5/8	3-1/16	1-5/8	2-1/2	.22	20	38
3/4	2-3/8	1-7/16	2-1/8	3-9/16	2	3	.36	30	76
1	2-5/8	1-5/8	2-1/8	3-7/8	2-5/16	3-15/16	.50	40	146
1-1/4	3-1/8	1-15/16	2-1/4	4-1/8	2-13/16	3-1/2	.75	60	292
1-1/2	3-9/16	2-3/8	2-3/4	4-5/8	3-1/16	3-7/8	1.00	80	412
2	4-5/16	3-1/16	3-5/8	5-1/2	3-3/4	5	2.00	90	720
3	6-3/16	4-3/8	5-3/8	8-1/8	5-1/2	7-5/8	7.00	300	1660
4	7-3/4	5-11/16	6-7/8	9-3/4	6-1/8	9-1/16	12.00	400	3104

1: Valve Lay Length

2: Torque required at valve maximum internal pressure rating, 5 ft./sec. flow velocity; due to adjustment differences during installation, actual values may vary.

3: Gallons per minute at 1 psi pressure drop. Values calculated from valve laying length, based on derivative of Hazen-Williams equation with surface roughness factor of C=150.

### Temperature Pressure Rating

System Operating Temperature °F (°C)			73 (23)	100 (38)	110 (43)	120 (49)	130 (54)	140 (60)	150 (66)
Valve Pressure Rating psi (MPa)	1/2" - 2"	PVC	235 (1.62)	146 (1.01)	118 (.81)	94 (.65)	71 (.49)	52 (.36)	-0- (-0-)
	3" - 4"	PVC	150 (1.03)	93 (.64)	75 (.52)	60 (.41)	45 (.31)	33 (.23)	-0- (-0-)

## CTS Quarter-Turn Angle Supply Stop



### Sample Engineering Specification

All thermoplastic Angle Supply Stops shall be Copper Tube Size (CTS) sealed unit type constructed from CPVC Type IV, ASTM D 1784 Cell Classification 23447. All O-rings shall be EPDM. All valves shall have Polypropylene handle. All Angle Supply Stops shall be pressure rated at 100 psi for water at 180°F, as manufactured by Spears® Manufacturing Company.

### Features – CPVC

Used at plumbing fixtures to terminate and control hot and cold water, this all-plastic quarter-turn shutoff valve is specially designed for use with CTS (Copper Tube Size) CPVC Hot & Cold Water Distribution Systems. Available in 1/2" CTS Socket or Spears® patented Special Reinforced (SR) 1/2" FIPT female thread inlet x 1/2" straight male thread outlet for connection to conventional 1/2" FPT faucet or toilet supply lines with captive seals.

- Easy 1/4-Turn Shutoff
- All Plastic Corrosion Proof Construction
- CTS CPVC Tan Colored Body with High Impact Polypropylene Handle
- High Quality EPDM Seals
- NSF® Certified to ASTM F 1970 for use in ASTM D 2846 Hot & Cold Water Distribution Systems rated to 100 psi @ 180°F

### Dimensions

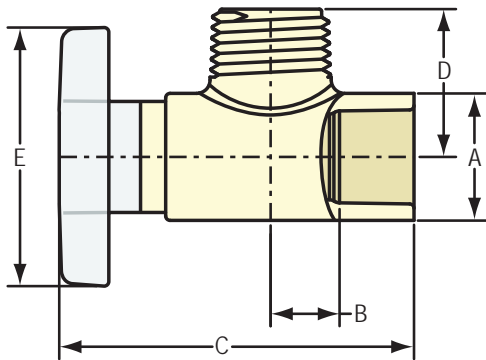

**1/4-Turn Angle Supply Stop**  
Socket x NPT

Nominal Size	A	B	C	D	E
1/2	7/8	7/16	2-1/16	1	2-1/16
1/2 x 3/8	7/8	7/16	2-3/8	7/8	2-1/16

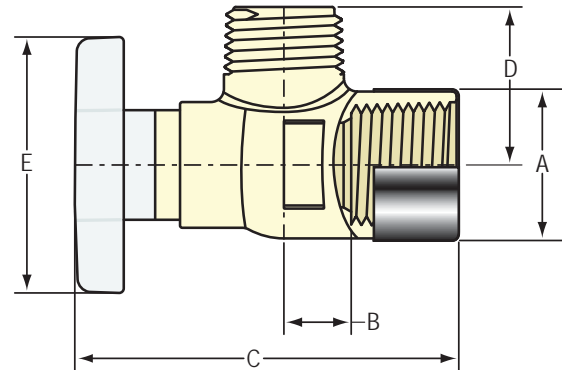

**1/4-Turn Angle Supply Stop**  
SR FiPT x NPT

Nominal Size	A	B	C	D	E
1/2	1-1/32	7/16	2-5/8	1-1/16	2-1/16
1/2 x 3/8	1-1/32	7/16	2-5/8	15/16	2-1/16

### Quick-View Valve Selection Chart

Valve Size	O-ring Material	Part Number		Pressure Rating
		Socket	SR Threaded	
1/2	EPDM	7722-005	7721-005SR	100 psi Non-Shock Water @ 180°F
1/2 x 3/8	EPDM	7722-073	7721-073SR	100 psi Non-Shock Water @ 180°F



## CTS Ball Valves



### Features – CPVC

A high quality, quarter-turn shutoff valve designed for line-stop use in Copper Tube Size (CTS) CPVC hot and cold water distribution systems as specified in ASTM D 2846. Approved by national, state and most municipal building codes for use in residential and commercial structures, as well as recreational vehicles, modular homes and mobile home applications. Check local codes for acceptability and restrictions. Available in CTS sizes 1/2" - 2" with socket end connectors.

- Chemical & Corrosion Resistant CPVC Construction
- Maintenance-Free Sealed Unit
- High Impact Polypropylene Handle
- Spears® Single O-ring Safe-T-Shear® Stem Design
- EPDM O-rings
- PTFE/HDPE Floating Seat Design
- Suitable for Commercial Hot Water Systems
- Sizes 1/2" - 2" Pressure Rated to 100 psi @ 180°F
- NSF® Certified for Potable Water use
- Assembled with Silicone-Free, Water Soluble Lubricant
- Manufactured to ASTM F 1970

### Sample Engineering Specification

All thermoplastic ball valves shall be Copper Tube Size (CTS) sealed unit type constructed from CPVC Type IV, ASTM D 1784 Cell Classification 23447. All O-rings shall be EPDM. All valves shall have double stop Polypropylene handle. All valves shall be certified by NSF International for use in potable water service. All valves shall be pressure rated at 100 psi for water at 180°F, as manufactured by Spears® Manufacturing Company.

### Quick-View Valve Selection Chart

Valve Size	O-ring Material	Part Number Socket	Pressure Rating
1/2	EPDM	1922-005	100 psi Non-Shock Water @ 180°F
3/4	EPDM	1922-007	
1	EPDM	1922-010	
1-1/4	EPDM	1922-012	
1-1/2	EPDM	1922-015	
2	EPDM	1922-020	

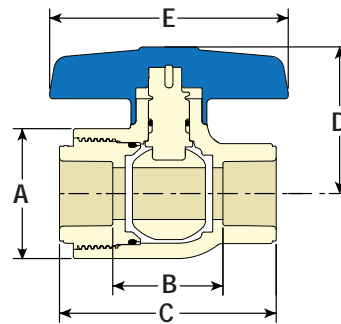

### Dimensions, Weights & C<sub>v</sub> Values

Part Number	Nominal Size	Dimension Reference (inches, ± 1/16)					Approx. Wt. (Lbs.)	C <sub>v</sub> <sup>2</sup> Values
		A	B <sup>1</sup>	C	D	E		
CBV-0500-S	1/2	1-7/32	1-11/16	2-3/32	1-11/32	2	.09	37
CBV-0750-S	3/4	1-9/16	1-11/32	2-25/32	1-3/4	2-23/32	.16	84
CBV-1000-S	1	1-7/8	1-9/16	3-3/8	2-3/8	3-1/2	.27	151
CBV-1250-S	1-1/4	2-13/32	1-15/16	4-3/16	2-25/32	3-3/4	.47	229
CBV-1500-S	1-1/2	2-27/32	2-3/8	5-1/32	3-5/32	4-9/32	1.05	330
CBV-2000-S	2	3-17/32	2-3/4	6-3/16	3-27/32	5	1.38	598

1: Valve Lay Length

2: Gallons per minute at 1 psi pressure drop. Values calculated from valve laying length, based on derivative of Hazen-Williams equation with roughness factor of C=150.



### True Union 2000 Retrofit Kits

Easily converts any system over to all True Union 2000 style valves for consistent valve type and uniform maintenance. Special extended socket style End Connectors (2) allow retrofit replacement of older Spears® and other brand valves in existing piping systems with a new True Union 2000 valve. Simply cut out old valve according to specified dimension and install retrofit end connectors. End connectors are provided with either EPDM or FKM O-rings.

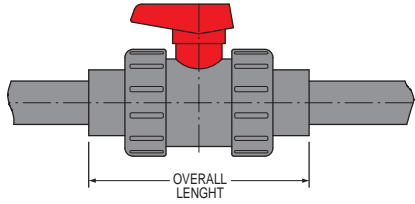

Ball Valve for Replacement

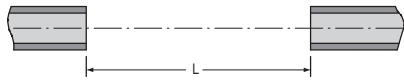

Pipe Laying Length After Cutting

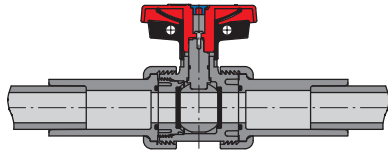

True Union 2000 Ball Valve Installed with Retrofit Kit

### True Union Retrofit Kits - Other Brand Valves (Socket Style Only)

Kit Size	EPDM		FKM	
	PVC	CPVC	PVC	CPVC
1/2	RFK2-005	RFK2-005C	RFK3-005	RFK3-005C
3/4	RFK2-007	RFK2-007C	RFK3-007	RFK3-007C
1	RFK2-010	RFK2-010C	RFK3-010	RFK3-010C
1-1/4	RFK2-012	RFK2-012C	RFK3-012	RFK3-012C
1-1/2	RFK2-015	RFK2-015C	RFK3-015	RFK3-015C
2	RFK2-020	RFK2-020C	RFK3-020	RFK3-020C
2-1/2	RFK2-025	RFK2-025C	RFK3-025	RFK3-025C
3	RFK2-030	RFK2-030C	RFK3-030	RFK3-030C
4	RFK2-040	RFK2-040C	RFK3-040	RFK3-040C

### Cut-Out Dimensions

Size	1/2	3/4	1	1-1/4	1-1/2	2	2-1/2	3	4
L	4-29/32	5-7/16	6-3/32	7-1/4	7-1/2	8-17/32	10-3/4	11-7/16	14-15/16

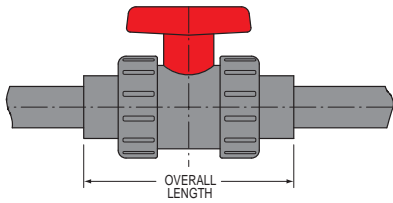

Ball Valve for Replacement

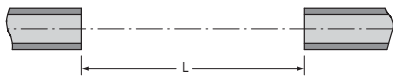

Pipe Laying Length After Cutting

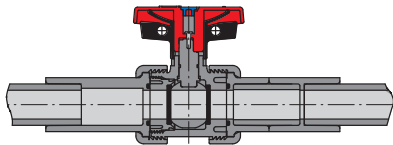

True Union Ball Valve Installed with Retrofit Kit

### True Union Retrofit Kits - Older (Regular Style) Spears® Valves (Socket Style Only)

Kit Size	EPDM		FKM	
	PVC	CPVC	PVC	CPVC
1/2	RFKS2-005	RFKS2-005C	RFKS3-005	RFKS3-005C
3/4	RFKS2-007	RFKS2-007C	RFKS3-007	RFKS3-007C
1	RFKS2-010	RFKS2-010C	RFKS3-010	RFKS3-010C
1-1/4	RFKS2-012	RFKS2-012C	RFKS3-012	RFKS3-012C
1-1/2	RFKS2-015	RFKS2-015C	RFKS3-015	RFKS3-015C
2	RFKS2-020	RFKS2-020C	RFKS3-020	RFKS3-020C
2-1/2	RFKS2-025	RFKS2-025C	RFKS3-025	RFKS3-025C
3	RFKS2-030	RFKS2-030C	RFKS3-030	RFKS3-030C
4	RFKS2-040	RFKS2-040C	RFKS3-040	RFKS3-040C

### Cut-Out Dimensions

Size	1/2	3/4	1	1-1/4	1-1/2	2	2-1/2	3	4
L	5-5/16	6-1/4	6-11/16	7-1/8	8-3/16	8-15/16	12	12-1/16	13-3/16



## Thermoplastic Valves Product Guide & Engineering Specifications

### Ball Valve Accessories

### True Union 2000 Retrofit Ball Valve Complete replacement valve for older Spears® 2300 series Regular True Union Ball Valves.

Retrofit valve consists of either Spears® Standard or Industrial True Union 2000 Ball Valve supplied with factory installed extended socket end connectors. Simply cut out old valve to specified dimensions (see preceding cut-out dimensions) and install Retrofit Valve end connectors.

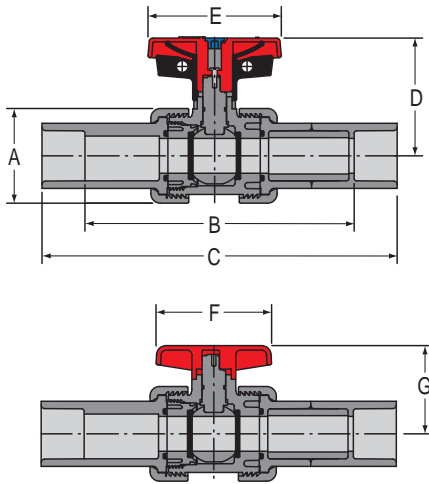

### Dimensions

Size	A ± 1/16	B ± 1/16	C ± 1/16	D ± 1/16	E ± 1/16	F ± 1/16	G ± 1/16
1/2	1-7/8	5-5/16	7-1/16	2-9/16	2-13/16	2-1/2	1-5/8
3/4	2-1/4	6-1/4	8-1/4	2-7/8	3-5/16	3	2
1	2-1/2	6-11/16	8-15/16	3-1/8	3-7/16	3-7/16	2-5/16
1-1/4	3-1/16	7-1/8	9-3/4	3-5/8	3-13/16	3-9/16	2-13/16
1-1/2	3-1/2	8-3/16	10-15/16	4	4-3/16	3-7/8	3-1/16
2	4-1/4	8-15/16	11-15/16	4-1/2	5-1/8	5	3-3/4
2-1/2	6-3/16	12	15-1/2	5-1/8	6-1/4	7-5/16	5-7/8
3	6-3/16	12-1/16	15-7/8	5-7/8	7-5/8	7-5/16	5-7/8
4	7-5/8	13-3/16	19	6-3/4	9-3/16	8-3/8	6-3/4

### True Union 2000 Retrofit Ball Valve - Replaces Older (Regular Style) Spears® Valves

Size	TU 2000 Industrial Retrofit Ball Valves				TU 2000 Standard Retrofit Ball Valves			
	EPDM		FKM		EPDM		FKM	
	PVC	CPVC	PVC	CPVC	PVC	CPVC	PVC	CPVC
1/2	1822RS-005	1822RS-005C	1832RS-005	1832RS-005C	3622RS-005	3622RS-005C	3632RS-005	3632RS-005C
3/4	1822RS-007	1822RS-007C	1832RS-007	1832RS-007C	3622RS-007	3622RS-007C	3632RS-007	3632RS-007C
1	1822RS-010	1822RS-010C	1832RS-010	1832RS-010C	3622RS-010	3622RS-010C	3632RS-010	3632RS-010C
1-1/4	1822RS-012	1822RS-012C	1832RS-012	1832RS-012C	3622RS-012	3622RS-012C	3632RS-012	3632RS-012C
1-1/2	1822RS-015	1822RS-015C	1832RS-015	1832RS-015C	3622RS-015	3622RS-015C	3632RS-015	3632RS-015C
2	1822RS-020	1822RS-020C	1832RS-020	1832RS-020C	3622RS-020	3622RS-020C	3632RS-020	3632RS-020C
2-1/2	1822RS-025	1822RS-025C	1832RS-025	1832RS-025C	3622RS-025	3622RS-025C	3632RS-025	3632RS-025C
3	1822RS-030	1822RS-030C	1832RS-030	1832RS-030C	3622RS-030	3622RS-030C	3632RS-030	3632RS-030C
4	1822RS-040	1822RS-040C	1832RS-040	1832RS-040C	3622RS-040	3622RS-040C	3632RS-040	3632RS-040C

### True Union 2000 Check Valve Seal Carrier Tool

Size	Part Number
1/2	TSK-00503
3/4	TSK-00703
1	TSK-01003
1-1/4	TSK-01203
1-1/2	TSK-01503
2	TSK-02003
3	TSK-03003
4	TSK-04003
6	TSK-06003



### True Union 2000 Ball Valve Seal Carrier Tool

Size	Part Number
1/2	TSK1-00503
3/4	TSK1-00703
1	TSK1-01003
1-1/4	TSK1-01203
1-1/2	TSK1-01503
2	TSK1-02003
3	TSK1-03003
4	TSK1-04003
6	TSK1-06003

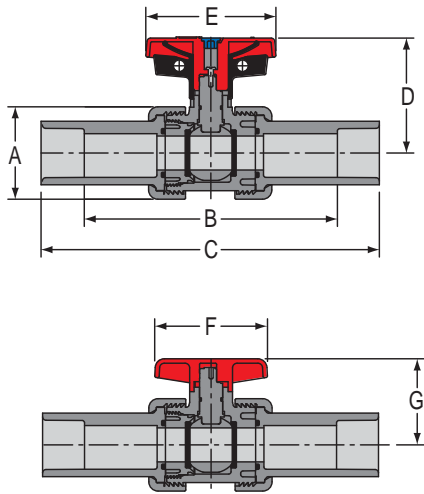

**True Union 2000 Retrofit Ball Valve Complete universal replacement valve for domestic and import PVC or CPVC valve.**

Retrofit consists of either Spears® Standard or Industrial True Union 2000 Ball Valve supplied with factory installed extended socket end connectors. Simply cut out old valve to specified dimensions (see cut-out dimensions, page 40) and install Retrofit Valve end connectors.

**Dimensions**

Size	A ± 1/16	B ± 1/16	C ± 1/16	D ± 1/16	E ± 1/16	F ± 1/16	G ± 1/16
1/2	1-7/8	4-15/16	6-11/16	2-9/16	2-13/16	2-1/2	1-5/8
3/4	2-1/4	5-7/16	7-1/2	2-7/8	3-3/8	3	2
1	2-1/2	6-1/16	8-5/16	3-1/8	3-7/16	3-7/16	2-5/16
1-1/4	3-1/16	7-5/16	9-7/8	3-5/8	3-7/8	3-9/16	2-13/16
1-1/2	3-1/2	7-1/2	10-5/16	4	4-3/16	3-7/8	3-1/16
2	4-1/4	8-1/2	11-1/2	4-1/2	5-1/8	5	3-3/4
2-1/2	6-3/16	10-7/8	14-3/8	5-7/8	7-5/8	7-5/16	5-7/8
3	6-3/16	11-1/2	15-3/16	5-7/8	7-5/8	7-5/16	5-7/8
4	7-5/8	14-3/8	18-15/16	6-3/4	9	8-3/8	6-3/4

**True Union 2000 Retrofit Ball Valve - Replaces Other Brand Valves**

Size	TU 2000 Industrial Retrofit Ball Valves				TU 2000 Standard Retrofit Ball Valves			
	EPDM		FKM		EPDM		FKM	
	PVC	CPVC	PVC	CPVC	PVC	CPVC	PVC	CPVC
1/2	1822R-005	1822R-005C	1832R-005	1832R-005C	3622R-005	3622R-005C	3632R-005	3632R-005C
3/4	1822R-007	1822R-007C	1832R-007	1832R-007C	3622R-007	3622R-007C	3632R-007	3632R-007C
1	1822R-010	1822R-010C	1832R-010	1832R-010C	3622R-010	3622R-010C	3632R-010	3632R-010C
1-1/4	1822R-012	1822R-012C	1832R-012	1832R-012C	3622R-012	3622R-012C	3632R-012	3632R-012C
1-1/2	1822R-015	1822R-015C	1832R-015	1832R-015C	3622R-015	3622R-015C	3632R-015	3632R-015C
2	1822R-020	1822R-020C	1832R-020	1832R-020C	3622R-020	3622R-020C	3632R-020	3632R-020C
2-1/2	1822R-025	1822R-025C	1832R-025	1832R-025C	3622R-025	3622R-025C	3632R-025	3632R-025C
3	1822R-030	1822R-030C	1832R-030	1832R-030C	3622R-030	3622R-030C	3632R-030	3632R-030C
4	1822R-040	1822R-040C	1832R-040	1832R-040C	3622R-040	3622R-040C	3632R-040	3632R-040C

**Split-Nut Repair Kits for All True Union 2000 Valves, Union 2000 Pipe Unions and True Union Diaphragm Valves**

- Allows replacement of broken Union Nuts
- No Reduction in Valve Operating Pressure
- Kit includes 2-piece Split Nut and SS 316 Gear Clamp
- Simply cut or remove broken nut, align Split-Nut halves around end connector and secure with Gear Clamp. Thread nut onto valve to complete repair.

**Note:** Split-Nut Repair Kit does **NOT** fit Regular Style True Union Valves



Valve Size	PVC Kit	CPVC Kit
1/2	SNK-005	SNK-005C
3/4	SNK-007	SNK-007C
1	SNK-010	SNK-010C
1-1/4	SNK-012	SNK-012C
1-1/2	SNK-015	SNK-015C
2	SNK-020	SNK-020C
2-1/2	SNK-025	SNK-025C
3	SNK-030	SNK-030C
4	SNK-040	SNK-040C



## Ball Valve Accessories



Socket End Connector Set (2)

### Supplemental End Connector Sets for All True Union 2000 Valves, Union 2000 Pipe Unions and True Union Diaphragm Valves

- Allows easy conversion of valve end connections due to system change, modification, or inadvertent misorder of product.
- Each set includes 2 each of either Socket, SR Threaded or Spigot End connectors with either EPDM or FKM O-rings installed.

Valve Size	PVC Part Number		CPVC Part Number	
	EPDM O-ring	FKM O-ring	EPDM O-ring	FKM O-ring
1/2	ECS2-005	ECS3-005	ECS2-005C	ECS3-005C
3/4	ECS2-007	ECS3-007	ECS2-007C	ECS3-007C
1	ECS2-010	ECS3-010	ECS2-010C	ECS3-010C
1-1/4	ECS2-012	ECS3-012	ECS2-012C	ECS3-012C
1-1/2	ECS2-015	ECS3-015	ECS2-015C	ECS3-015C
2	ECS2-020	ECS3-020	ECS2-020C	ECS3-020C
2-1/2	ECS2-025	ECS3-025	ECS2-025C	ECS3-025C
3	ECS2-030	ECS3-030	ECS2-030C	ECS3-030C
4	ECS2-040	ECS3-040	ECS2-040C	ECS3-040C
6	ECS2-060	ECS3-060	ECS2-060C	ECS3-060C

SR Threaded End Connector Set (2)

Valve Size	PVC Part Number		CPVC Part Number	
	EPDM O-ring	FKM O-ring	EPDM O-ring	FKM O-ring
1/2	ECSRT2-005	ECSRT3-005	ECSRT2-005C	ECSRT3-005C
3/4	ECSRT2-007	ECSRT3-007	ECSRT2-007C	ECSRT3-007C
1	ECSRT2-010	ECSRT3-010	ECSRT2-010C	ECSRT3-010C
1-1/4	ECSRT2-012	ECSRT3-012	ECSRT2-012C	ECSRT3-012C
1-1/2	ECSRT2-015	ECSRT3-015	ECSRT2-015C	ECSRT3-015C
2	ECSRT2-020	ECSRT3-020	ECSRT2-020C	ECSRT3-020C
2-1/2	ECSRT2-025	ECSRT3-025	ECSRT2-025C	ECSRT3-025C
3	ECSRT2-030	ECSRT3-030	ECSRT2-030C	ECSRT3-030C
4	ECSRT2-040	ECSRT3-040	ECSRT2-040C	ECSRT3-040C
6	ECSRT2-060	ECSRT3-060	ECSRT2-060C	ECSRT3-060C



Spigot End Connector Set (2)

Valve Size	PVC Part Number		CPVC Part Number	
	EPDM O-ring	FKM O-ring	EPDM O-ring	FKM O-ring
1/2	ECSP2-005	ECSP3-005	ECSP2-005C	ECSP3-005C
3/4	ECSP2-007	ECSP3-007	ECSP2-007C	ECSP3-007C
1	ECSP2-010	ECSP3-010	ECSP2-010C	ECSP3-010C
1-1/4	ECSP2-012	ECSP3-012	ECSP2-012C	ECSP3-012C
1-1/2	ECSP2-015	ECSP3-015	ECSP2-015C	ECSP3-015C
2	ECSP2-020	ECSP3-020	ECSP2-020C	ECSP3-020C
2-1/2	ECSP2-025	ECSP3-025	ECSP2-025C	ECSP3-025C
3	ECSP2-030	ECSP3-030	ECSP2-030C	ECSP3-030C
4	ECSP2-040	ECSP3-040	ECSP2-040C	ECSP3-040C
6	ECSP2-060	ECSP3-060	ECSP2-060C	ECSP3-060C

### Handle Lockout Ring for True Union 2000 Industrial Ball Valves

- Use with Built-in Handle Lockout Device
- Allows selective lockout position of Lock-Open Only or Lock-Closed Only
- Simply remove valve handle and install ring below handle lockout mechanism

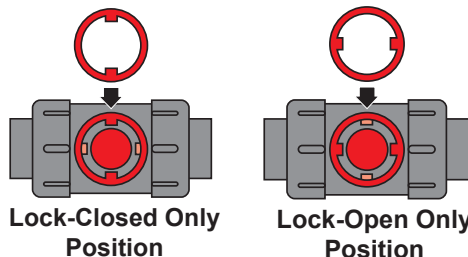

Valve Size	Part Number
1/2	TU2LR-005
3/4	TU2LR-007
1	TU2LR-010
1-1/4	TU2LR-012
1-1/2	TU2LR-015
2	TU2LR-020
2-1/2 & 3	TU2LR-030
4	TU2LR-040



Typical Application  
 (VALVE AND RISER NOT INCLUDED)

### Stem Extension Kits

- Kits for True Union 2000 Valves and for Regular True Union, Single Entry or Compact Ball Valves
- Simple 2-Piece Kit for use with existing Valve Handle and Schedule 80 pipe, or can be ordered factory assembled to desired length as 1-piece unit.
- Kit includes 1 - Stem Adapter and 1 - Handle Adapter
- Corrosion resistant PVC construction

### 2-Piece Stem Extension Kit

Valve Size	Part Numbers <sup>1</sup>	
	For True Union 2000, Compact 2000 & Single Entry Ball Valves <sup>2</sup>	For Regular True Union & Compact Ball Valves
1/2	BVSE2-005-000	BVSE-005-000
3/4	BVSE2-007-000	BVSE-007-000
1	BVSE2-010-000	BVSE-010-000
1-1/4	BVSE2-012-000	BVSE-012-000
1-1/2	BVSE2-015-000	BVSE-015-000
2	BVSE2-020-000	BVSE-020-000
2-1/2 & 3	BVSE2-030-000	BVSE-030-000
4	BVSE2-040-000	BVSE-040-000
6	BVSE2-060-000	N/A

1: For factory assembled units replace last 3 zeros with length code. See **SSB-1 Part 1 List Price Catalog – Thermoplastic Valves, Ball Valve Accessories & Repair Kits** for length codes.  
 2: Not for use on True Union 2000 Industrial 3-Way Ball Valves

#### Required for Assembly:

- Two-Piece Stem Extension Kit
- Desired Length of PVC Schedule 80 Pipe\*
- Saw & Miter Box or Wheel-Type Cutter
- PVC Solvent Cement & Primer
- Black Marker
- Ruler

\* NOT INCLUDED

1. Cut pipe square to desired length (See Table Below).
2. Bevel and deburr pipe ends.
3. Align edge of print string or mark each end of pipe for alignment; check dry fit.
4. Solvent cement components to pipe making sure alignment marks are properly matched.
5. Push valve handle onto extension assembly.
6. Position assembly over valve stem and rotate into place.

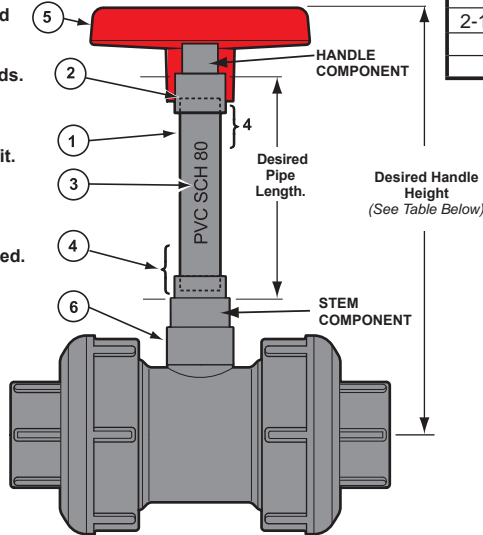

Use the Schedule 80 pipe size listed for the appropriate valve size										
Valve Size (in.)	1/2	3/4	1	1-1/4	1-1/2	2	2-1/2	3	4	6
Required Sch 80 Pipe Size	3/4			1			1-1/2			
To calculate the length of Schedule 80 pipe needed, <b>subtract</b> the appropriate figure shown below from the desired handle height										
<b>For True Union 2000 Industrial Ball Valves<sup>1</sup></b>										
Valve Size (in.)	1/2	3/4	1	1-1/4	1-1/2	2	2-1/2	3	4	6
Subtract (in.)	3-7/8	4	4-5/16	5	5-5/8	6-1/4	8-1/16	8-1/16	9-5/8	10-11/16
Minimum Height (in.)	4-9/16	5-3/16	5-1/2	6-3/4	7-3/8	8	9-13/16	9-13/16	11-5/8	12-3/4
<b>For True Union 2000 Standard, Compact 2000 &amp; Single Entry Ball Valves</b>										
Valve Size (in.)	1/2	3/4	1	1-1/4	1-1/2	2	2-1/2	3	4	N/A
Subtract (in.)	2-1/2	3-1/16	3-9/16	4-1/4	4-5/8	5-11/16	7-11/16	7-11/16	9	N/A
Minimum Height (in.)	3-5/8	4-1/4	4-3/4	6	6-3/8	7-7/16	9-1/2	9-1/2	11	N/A
<b>For Regular True Union &amp; Compact Ball Valves</b>										
Valve Size (in.)	1/2	3/4	1	1-1/4	1-1/2	2	2-1/2	3	4	N/A
Subtract (in.)	3-5/16	4	4-5/16	5-1/8	5-5/8	6-1/16	7-1/8	7-1/8	8-3/8	N/A
Minimum Height (in.)	4-1/2	5-1/4	5-1/2	7	7-1/2	8	9	9	10-1/2	N/A

1: Stem Extension does not permit use of Handle Lockout on True Union 2000 Industrial Ball Valves.





## Thermoplastic Valves Product Guide & Engineering Specifications

### Ball Valve Accessories

### Round Safety Handles

- Handles for True Union 2000 Valves and for Regular True Union, Single Entry or Compact Ball Valves
- Helps prevent accidental operation of valve
- Special design provides positive hand grip
- Impact and corrosion resistant Polypropylene construction

**Note:** Round Handle does not allow use of Handle Lockout on True Union 2000 Industrial Ball Valve. Not for use on True Union 2000 Industrial 3-Way Ball Valve.

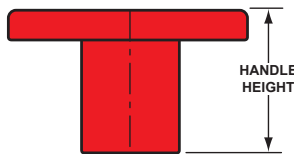
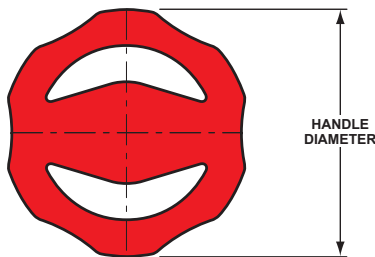

*Typical Application  
(VALVE NOT INCLUDED)*

Valve Size	Part Numbers					Handle Height	Handle Diameter
	For TU 2000, Compact 2000, & Single Entry, & Utility Ball Valves		For Regular True Union & Compact Ball Valves				
	3-Slot Stem	1-Slot Stem	3-Slot Stem	1-Slot Stem	Flat/2-D Stem		
1/2	RSH2-005	RSH5-005	RSH-005	RSH6-005	RSH4-005	1-13/32	2-1/2
3/4	RSH2-007	RSH5-007	RSH-007	RSH6-007	RSH4-007	1-9/16	2-7/8
1	RSH2-010	RSH5-010	RSH-010	RSH6-010	RSH4-010	1-9/16	3-1/4
1-1/4	RSH2-012	RSH5-012	RSH-012	RSH6-012	RSH4-012	1-13/16	3-9/16
1-1/2	RSH2-015	RSH5-015	RSH-015	RSH6-015	RSH4-015	1-15/16	4-3/16
2	RSH2-020	RSH5-020	RSH-020	RSH6-020	RSH4-020	2-1/4	5-1/16
2-1/2 & 3	RSH2-030	RSH5-030	NA	NA	RSH-030	2-3/4	6-11/16
4	RSH2-040	RSH5-040	NA	NA	RSH-040	3	8-1/8

### 2" Square / T-Style Operator Nuts

- Operator Nuts for True Union 2000 Valves and for Regular True Union, Single Entry or Compact Ball Valves
- Designed for use with standard 2" square drive or conventional "T" drive operators

**Note:** Not for use on True Union 2000 Industrial 3-Way Ball Valves



Valve Size	Part Numbers		
	All True Union (Reg./2000) Compact, Compact 2000 & Single Entry Ball Valves	For True Union 2000 Industrial, Standard & Single Entry Ball Valves	For Regular True Union & Compact Ball Valves
1/2	VTN2-005	N/A	N/A
3/4	VTN2-007		
1	VTN2-010		
1-1/4	VTN2-012		
1-1/2	VTN2-015		
2	VTN2-020		
2-1/2 & 3	N/A	VTN2-030	VTN-030
4	N/A	VTN2-040	VTN-040



### Multi-Mount Valve Mounting Brackets

- Separate Brackets for True Union 2000 Industrial & Standard Ball Valves and for Regular True Union Ball Valves.
- Provides solid, versatile valve mounting to machinery supports, panels, etc.
- Simple 2-piece clamp-on unit allows quick removal of valve for maintenance or servicing without altering position.
- Includes mounting hardware.
- Impact and corrosion resistant Polypropylene construction.
- Easily adapts to actuator mount using optional Multi-Mount Actuator Mounting Platform.

- Notes:**
- 1) Bracket does not fit True Union 2000 Industrial 3-Way Ball Valves.
  - 2) True Union 2000 Valve brackets come with Stainless Steel hardware, Regular True Union brackets come with zinc-plated steel hardware.
  - 3) Will not fit with Low Profile Actuation Mounting Kit.

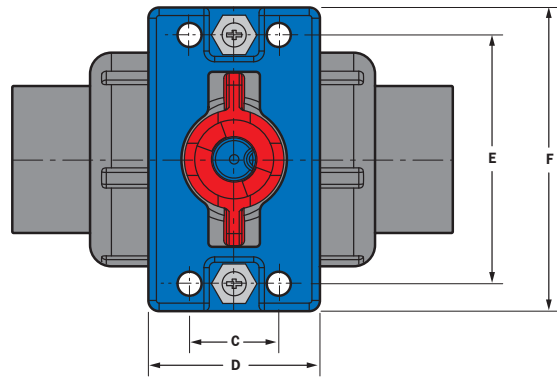
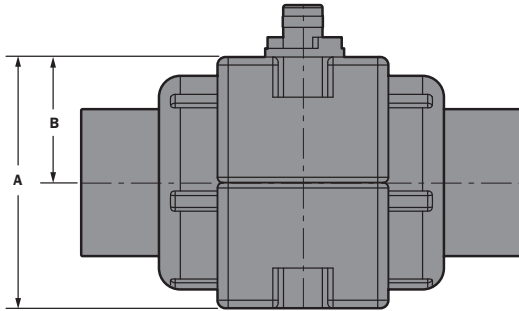

### Multi-Mount Valve Mounting Brackets

#### True Union 2000 Industrial Ball Valve

Valve Size	Part Number	Dimensions					
		A	B	C	D	E	F
1/2	TUMB2-005	2.38	1.19	1.04	1.72	2.46	3.54
3/4	TUMB2-007	2.82	1.41	1.10	1.81	2.75	3.54
1	TUMB2-010	2.98	1.49	1.04	2.00	2.90	3.54
1-1/4	TUMB2-012	3.60	1.80	1.25	2.00	3.50	4.13
1-1/2	TUMB2-015	4.00	2.00	1.38	2.15	3.90	4.53
2	TUMB2-020	5.00	2.50	1.50	2.50	4.50	5.10
2-1/2 & 3	TUMB2-030	6.30	3.15	2.00	3.25	6.25	7.00
4	TUMB2-040	8.25	4.12	2.00	4.10	7.72	8.50

#### Regular True Union Ball Valve

Valve Size	Part Number	Dimensions					
		A	B	C	D	E	F
1/2	TUMB-005	2.92	1.46	0.68	1.55	2.25	4.44
3/4	TUMB-007	3.54	1.77	0.94	1.87	2.55	4.87
1	TUMB-010	3.56	1.78	1.05	2.00	2.87	5.12
1-1/4	TUMB-012	3.98	1.99	1.19	2.09	3.25	5.31
1-1/2	TUMB-015	4.54	2.27	1.47	2.47	3.84	5.90
2	TUMB-020	5.56	2.78	1.81	2.75	4.75	7.00
2-1/2 & 3	TUMB-030	7.54	3.77	2.47	3.75	6.87	9.47
4	TUMB-040	9.16	4.58	2.72	4.19	8.28	11.41



## Thermoplastic Valves Product Guide & Engineering Specifications

### Ball Valve Accessories



### Multi-Mount Actuator Mounting Platforms

- Separate Platforms for True Union 2000 Valves and for Regular True Union Ball Valves.
- Add-on actuator adapter for use with Multi-Mount Valve Mounting Bracket (may also be purchased with bracket as complete kit).
- Universal actuator mounting accepts ISO, MSS or comparable square bolt-pattern actuators.
- Impact and corrosion resistant Polypropylene construction.
- Includes hardware for mounting Platform to Bracket

**Notes:**

- 1) True Union 2000 Valve platforms come with Stainless Steel hardware, Regular True Union platform come with zinc-plated steel hardware.
- 2) See Complete Multi-Mount Actuation Mounting Kit for applicable dimensions.

Valve Size	Part Numbers	
	For True Union 2000 Ball Valves	For Regular True Union Ball Valves
1/2	MMP1-005	MMP-005
3/4	MMP1-007	MMP-007
1	MMP1-010	MMP-010
1-1/4	MMP1-012	MMP-012
1-1/2	MMP1-015	MMP-015
2	MMP1-020	MMP-020
2-1/2 & 3	MMP1-030	MMP-030
4	MMP1-040	MMP-040

### Complete Multi-Mount Actuation Mounting Kits



- Separate Platforms for True Union 2000 Industrial Ball Valves & for True Union 2000 Standard Ball Valves and for Regular True Union Ball Valves.
- Combines Multi-Mount Valve Mounting Bracket and Multi-Mount Actuator Mounting Platform into one complete kit.
- Provides solid, fully supported valve and actuator mounting.
- Impact and corrosion resistant Polypropylene construction.
- Bracket and platform hardware included

- NOTES:**
- 1) True Union 2000 Valve kits come with Stainless Steel hardware, Regular True Union kits come with zinc-plated steel hardware.
  - 2) Does not fit True Union 2000 Industrial 3-way Ball Valves
  - 3) Actuator coupling not included (see Valve Stem Output Detail for design of user supplied drive coupling).

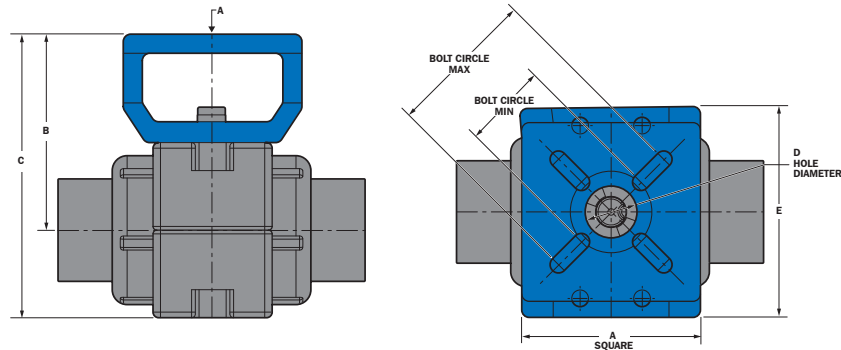

Valve Size	True Union 2000 Ball Valves	Regular True Union Ball Valves	Dimensions									
			A	TU 2000 B	Reg. TU B	TU 2000 C	Reg. TU C	D	TU 2000 E	Reg. TU E	Bolt Circle Max	Bolt Circle Min.
1/2	TUAK1-005	TUAK-005	3.00	3.00	3.24	4.19	4.67	.87	3.54	4.44	2.50	1.41
3/4	TUAK1-007	TUAK-007	3.00	3.13	3.46	4.54	5.20	.87	3.54	4.87	2.50	1.41
1	TUAK1-010	TUAK-010	3.00	3.31	3.60	4.88	5.38	.87	3.54	5.12	2.50	1.41
1-1/4	TUAK1-012	TUAK-012	3.75	4.64	4.80	6.44	6.76	.90	4.13	5.31	3.00	1.41
1-1/2	TUAK1-015	TUAK-015	3.75	5.02	5.27	7.02	7.52	.90	4.53	5.90	3.00	1.41
2	TUAK1-020	TUAK-020	3.75	5.52	5.77	8.02	8.52	1.12	5.10	7.00	3.12	1.75
2-1/2 & 3	TUAK1-030	TUAK-030	5.25	6.34	6.91	9.49	10.63	1.37	7.00	9.47	5.00	2.20
4	TUAK1-040	TUAK-040	5.25	7.99	8.36	12.11	12.86	1.37	8.50	11.41	5.00	2.20



### Low Profile Actuation Mounting Kits

- Separate kits for True Union 2000 Industrial & Industrial 3-Way Ball Valves and for True Union 2000 Standard Ball Valves.
- Compact bolt-on mount provides positive actuator support and alignment.
- Universal actuator mounting plate accepts ISO, MSS or comparable square bolt-pattern actuators.
- Impact and corrosion resistant Polypropylene construction.
- Includes Stainless Steel hardware for mounting to valve.

**Notes:** 1) Actuator coupling not included (see Valve Stem Output Detail for design of user supplied drive coupling).  
 2) Will not assemble with Multi-Mount Valve mounting bracket – See Mini-Mount Actuation Mounting Kit or Mini-Mount Combo Actuation Mounting Kit.

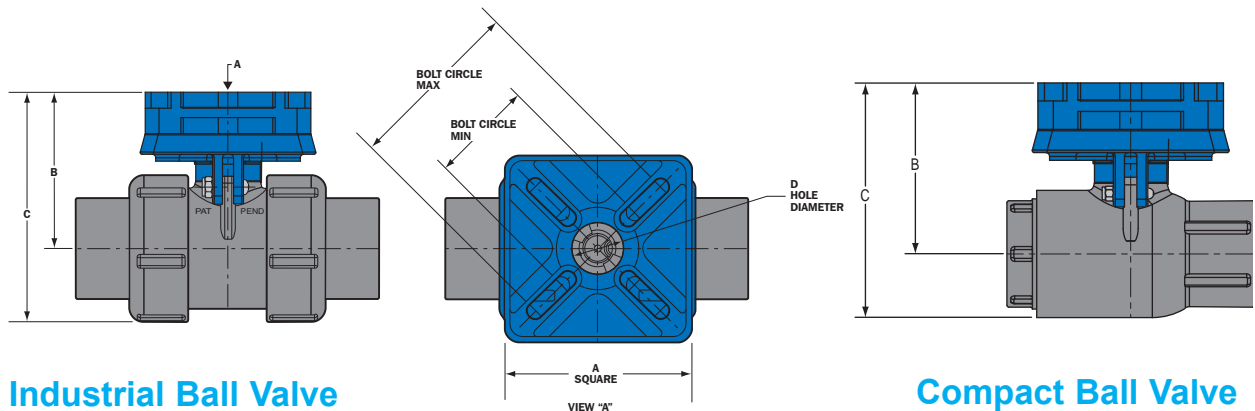

**Industrial Ball Valve**

**Compact Ball Valve**

### Dimensions

Valve Size	True Union 2000 Ind Ball Valves	True Union 2000 Std Ball Valves	Compact 66-Series	Dimensions							
				A	TU 2000 B	66 Series B	TU 2000 C	66 Series C	D	Bolt Circle Max.	Bolt Circle Min.
1/2	AMB5-005	AMB6-005		3.18	2.45	2.45	3.38	3.16	0.87	3.00	1.62
3/4	AMB5-007	AMB6-007		3.18	2.61	2.61	3.78	3.50	0.87	3.00	1.75
1	AMB5-010	AMB6-010		3.18	2.77	2.77	4.10	3.79	0.87	3.00	1.75
1-1/4	AMB5-012	AMB6-012		3.68	3.40	3.40	4.97	4.68	0.87	3.75	2.00
1-1/2	AMB5-015	AMB6-015		3.68	3.64	3.64	5.42	5.12	0.87	3.75	2.00
2	AMB5-020	AMB6-020		3.68	4.31	4.31	6.45	6.10	1.12	3.75	2.50
2-1/2 & 3	AMB5-030	AMB6-030	N/A	5.25	5.56	N/A	8.64	N/A	1.96	5.62	4.50
4	AMB5-040	AMB6-040	N/A	5.75	6.11	N/A	9.97	N/A	2.68	5.88	4.80
6	AMB5-060	N/A	N/A	5.75	7.92	N/A	13.73	N/A	2.88	5.88	4.80





## Thermoplastic Valves Product Guide & Engineering Specifications

### Ball Valve Accessories

### Mini-Mount Actuation Mounting Kits



- Separate kits for True Union 2000 Industrial & Industrial 3-Way Ball Valves and for True Union 2000 Standard Ball Valves.
- Simple bolt-on mount provides positive actuator support and alignment.
- Universal actuator mounting plate accepts ISO, MSS or comparable square bolt-pattern actuators.
- Impact and corrosion resistant Polypropylene construction.
- Includes Stainless Steel hardware for mounting to valve.

**Note:** 1) Actuator coupling not included (see Valve Stem Output Detail for design of user supplied drive coupling).

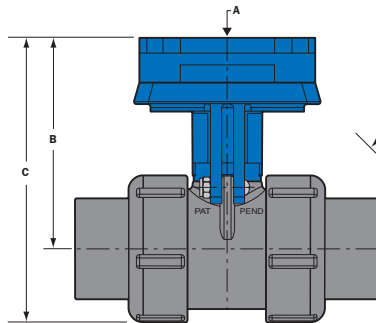

**Industrial Ball Valve**

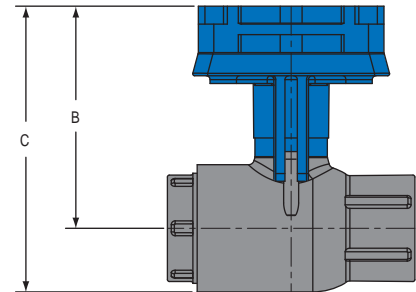
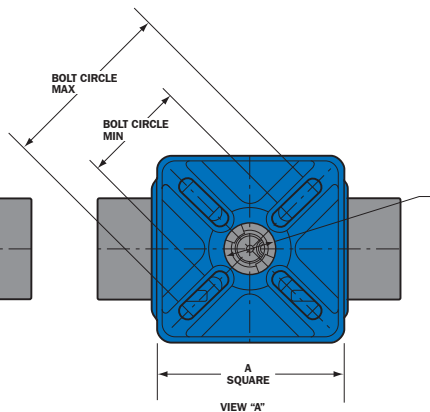

**Compact Ball Valve**

### Dimensions

Valve Size	TU 2000 Ind Ball Valves	TU 2000 Std Ball Valves	Compact 66-Series	Compact 21-Series	Dimensions									
					A	TU 2000 B	66 Series B	21 Series B	TU 2000 C	66 Series C	21 Series C	D	Bolt Circle Max.	Bolt Circle Min.
1/2	AMB2-005	AMB3-005		AMB4-005	3.18	2.95	2.95	2.90	3.88	3.66	3.75	0.87	3.00	1.62
3/4	AMB2-007	AMB3-007		AMB4-007	3.18	3.36	3.36	3.47	4.53	4.25	4.51	0.87	3.00	1.75
1	AMB2-010	AMB3-010		AMB4-010	3.18	3.60	3.60	3.61	4.93	4.62	4.80	0.87	3.00	1.75
1-1/4	AMB2-012	AMB3-012		AMB4-012	3.68	4.37	4.37	4.30	5.94	5.65	5.71	0.87	3.75	2.00
1-1/2	AMB2-015	AMB3-015		AMB4-015	3.68	4.64	4.64	4.60	6.42	6.12	6.22	0.87	3.75	2.00
2	AMB2-020	AMB3-020		AMB4-020	3.68	5.47	5.47	5.32	7.61	7.26	7.38	1.12	3.75	2.50
2-1/2 & 3	AMB2-030	AMB3-030	N/A	AMB4-030	5.25	6.15	N/A	5.87	9.23	N/A	8.87	1.96	5.62	4.50
4	AMB2-040	AMB3-040	N/A	AMB4-040	5.75	6.92	N/A	6.91	10.78	N/A	10.59	2.68	5.88	4.80
6	AMB2-060	N/A	N/A	AMB2-060	5.75	8.31	N/A	8.31	14.12	N/A	13.39	2.88	5.88	4.85



**Mini-Mount Combo Actuation Mounting Kits**



- Separate, complete actuation mounting kit specially designed for True Union 2000 Industrial Ball Valve and for True Union 2000 Standard Ball Valve.
- Combines Multi-Mount Bracket with Mini-Mount Actuation Mounting Kit for additional mounting support.
- Universal actuator mounting plate accepts ISO, MSS or comparable square bolt-pattern actuators.
- Impact and corrosion resistant Polypropylene construction.
- Includes Stainless Steel hardware for mounting to valve.

**Notes:** 1) Does not fit True Union 2000 Industrial 3-way Ball Valves

2) Actuator coupling not included (see Valve Stem Output Detail for design of user supplied drive coupling).

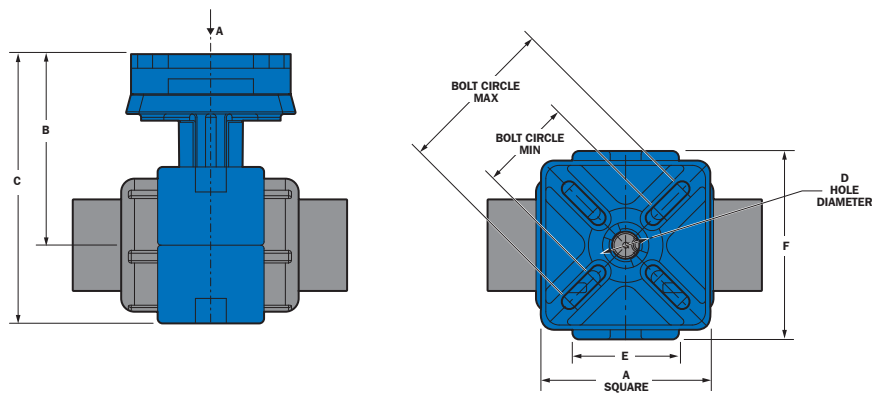

**Dimensions**

Valve Size	True Union 2000 Industrial Ball Valves	True Union 2000 Standard Ball Valves	Dimensions							
			A	B	C	D	E	F	Bolt Circle Max.	Bolt Circle Min.
1/2	TUAK2-005	TUAK3-005	3.18	2.95	4.14	.87	1.72	3.54	3.00	1.62
3/4	TUAK2-007	TUAK3-007	3.18	3.36	4.77	.87	1.81	3.54	3.00	1.75
1	TUAK2-010	TUAK3-010	3.18	3.60	5.09	.87	2.00	3.54	3.00	1.75
1-1/4	TUAK2-012	TUAK3-012	3.68	4.37	6.17	.87	2.00	4.13	3.75	2.00
1-1/2	TUAK2-015	TUAK3-015	3.68	4.64	6.64	.87	2.15	4.53	3.75	2.00
2	TUAK2-020	TUAK3-020	3.68	5.47	7.97	1.12	2.50	5.10	3.75	2.50
2-1/2 & 3	TUAK2-030	TUAK3-030	5.75	6.15	9.30	1.96	3.25	7.00	5.62	4.50
4	TUAK2-040	TUAK3-040	5.75	6.92	11.05	2.68	4.10	8.50	5.88	4.80

**Standard and Compact Foot Valve Screens**



- Easily converts Ball Check Valve to a Foot Valve.
- Standard IPS spigot connection fits slip-socket valve end connector.
- Enlarged screen provides open area equivalent to valve for optimum flow characteristics.
- Chemical and corrosion resistant PVC, CPVC or Compact HDPE threaded construction.
- Compact fits any IPS socket or threaded Ball Check Valve



Typical Application  
(VALVE NOT INCLUDED)



## Thermoplastic Valves Product Guide & Engineering Specifications

### Ball Valve Accessories

### Standard Dimensions

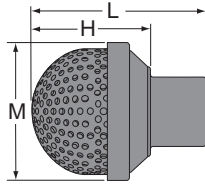

Size	Part Number		L	H	M
	PVC	CPVC			
1/2	FVS-005	FVS-005C	±1/16	±1/32	±1/16
3/4	FVS-007	FVS-007C	3-1/2	2-7/16	2-5/16
1	FVS-010	FVS-010C	3-5/8	2-9/16	2-5/8
1-1/4	FVS-012	FVS-012C	3-7/8	2-9/16	2-5/8
1-1/2	FVS-015	FVS-015C	5-15/32	4-1/64	4-7/16
2	FVS-020	FVS-020C	5-1/2	4-1/64	4-7/16
2-1/2	FVS-025	FVS-025C	6-7/16	4-3/4	5-5/8
3	FVS-030	FVS-030C	6-5/8	4-3/4	5-11/16
4	FVS-040	FVS-040C	6-29/32	4-3/4	5-3/4
6	FVS-060	FVS-060C	7-3/8	4-11/16	7-3/16

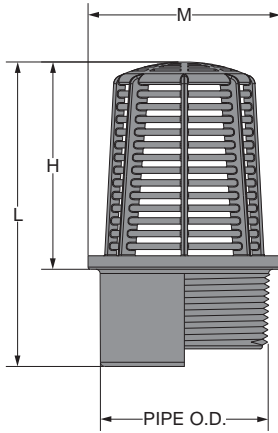

### Compact Dimensions

Size	Part Number			H	L		M	
	Threaded		Spigot		±1/16		±1/16	
	PVC	HDPE	PVC	±1/32	Threaded	Spigot	Threaded	Spigot
1/2	CFVS1-005	CFVS1-005P	CFVS7-005	1-9/16	2-7/32	2-5/16	31/32	1-3/32
3/4	CFVS1-007	CFVS1-007P	CFVS7-007	1-27/32	2-1/2	2-25/32	1-7/32	1-5/16
1	CFVS1-010	CFVS1-010P	CFVS7-010	2-1/16	2-7/8	3-3/32	1-7/16	1-5/8
1-1/4	CFVS1-012	CFVS1-012P	CFVS7-012	2-7/32	3-1/4	3-15/32	1-27/32	2
1-1/2	CFVS1-015	CFVS1-015P	CFVS7-015	2-19/32	3-5/8	3-29/32	2-1/8	2-1/4
2	CFVS1-020	CFVS1-020P	CFVS7-020	2-15/16	4	4-5/16	2-5/8	2-3/4

### Valve Stem Output Detail

For All True Union 2000, Compact 2000, & Single Entry Ball Valves

Size	A (max.)	B (max.)	C (max.)	D (max.)	E (max.)		Flat (max.)	Fig
					1-PIN SLOT	3-PIN SLOT		
1/2	1.43	.26	.52	.26	.30	.21	N/A	3
3/4	1.79	.33	.56	.28	.30	.21		
1	2.10	.41	.62	.31	.33	.23		
1-1/4	2.61	.55	.56	.28	.32	.19		
1-1/2	2.87	.62	.75	.37	.38	.27		
2	3.52	.65	.95	.47	.44	.31		
2-1/2 & 3	5.28	1.16	1.28	.63	.56	.44	1.92	1
4	5.81	.91	1.86	.93	.75	.63		
6	7.53	1.33	2.12	N/A	N/A	N/A		

For Regular True Union & Compact\* Ball Valves

Size	A (max.)	B (max.)	C (max.)	D (max.)	E (max.)	Flat (max.)	Fig.
1/2	1.48	.31	.52	.26	.21	N/A	3
3/4	1.88	.35	.56	.28	.21		
1	2.18	.48	.62	.31	.23		
1-1/4	2.66	.66	.56	.28	.19		
1-1/2	2.87	.67	.75	.37	.27		
2	3.60	.89	.95	.47	.31		
2-1/2 & 3	4.86	1.01	1.48	N/A	N/A	1.21	1
4	6.24	1.33	2.12			1.92	
6	7.53	1.33	2.12			1.92	

\*The 2-1/2", 3" & 4" regular Compact Ball Valves have the same stem output detail as specified in the True Union 2000, Compact 2000, & Single Entry Ball Valves in preceding table.

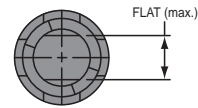

FIG. 1

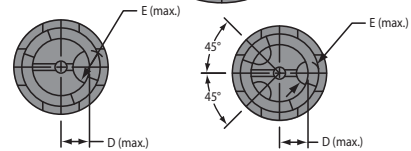
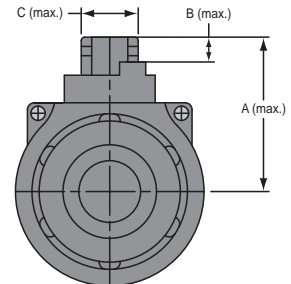
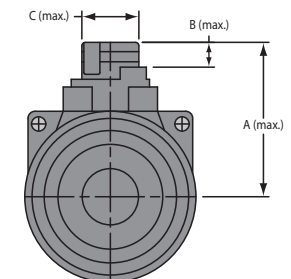

FIG. 2

FIG. 3



**Thermoplastic Valves Product Guide & Engineering Specifications**  
**Ball Valve Troubleshooting Guide**



Spears® True Union, Single Entry and Compact Ball Valves are designed and produced for trouble-free operation and use. However, certain aspects of installation and application can result in valve malfunctions.

This guide identifies some of the more common problems encountered and their necessary corrective actions. Such problems have been categorized as External Leaks, Internal Leaks, Frozen Movements and Structural Breakage.

<b>External Leaks</b>		
<b>Location</b>	<b>Possible Cause</b>	<b>Corrective Action</b>
At Thread/Socket Connections	<p>Improper solvent cementing.</p> <p>Improper threads.</p> <p>Insufficient or improperly applied thread sealant; incompatible sealant (paste).</p> <p>Over-tightened thread joint splitting connector.</p> <p>Insufficient valve support splitting connector.</p>	<p>Replace end connector(s) according to installation instructions.</p> <p>Check threads for proper size; replace or reinstall.</p> <p>Reinstall thread connection according to proper procedures; check paste compatibility.</p> <p>Replace cracked end connector(s).</p> <p>Replace cracked end connector(s). Add support on each side of valve.</p>
At Union Nuts	<p>End connector misaligned.</p> <p>Displaced or damaged O-ring; particles in O-ring groove.</p> <p>System contraction pulling end connectors; improper end connector spacing.</p> <p>Loose Union Nut.</p> <p>Displaced or pinched seal carrier O-ring.</p>	<p>Check system alignment - end connector(s) must be parallel. Check for adequate valve support.</p> <p>Remove valve and inspect O-ring for physical or chemical damage. Check O-ring compatibility, replace accordingly. Clean and re-seat O-ring.</p> <p>Check thermal variations; anchor pipe each side of valve; install expansion loop. Correct spacing.</p> <p>Re-tighten nut.</p> <p>Remove and disassemble seal carrier; re-seat or replace O-ring.</p>
At Stem	<p>Damaged stem O-ring.</p>	<p>Remove and disassemble valve stem; inspect for physical or chemical damage. Check O-ring compatibility, clean and replace accordingly.</p>





## Thermoplastic Valves Product Guide & Engineering Specifications

### Ball Valve Troubleshooting Guide

#### Internal Leaks — In-line Leakage Past Valve

Possible Cause	Corrective Action
Ball obstruction	Check that the valve is in its "full-closed" position. If not, remove valve and check for solids blocking the ball port. Clean and reinstall valve.
Broken Stem	Remove end connector and check for ball rotation while operating valve. Replace as necessary.
Seal Carrier Loose	True Union Valves - remove valve; CAREFULLY tighten seal carrier (located on inlet end of body). Single Entry Valves - CAREFULLY tighten single Union Nut. IMPORTANT: Generally only a slight adjustment is required (either valve). A properly adjusted valve should have significant resistance to operation without binding - AVOID OVER-TIGHTENING!
PTFE Seat Damage or Debris Laden	Remove and disassemble valve seats. Check for excessive debris and physical damage (nicks, cuts, scoring, etc.). Clean and replace as necessary.
Seat O-ring Displaced, Damaged or Debris Laden	Remove and disassemble valve seat O-rings; check for physical or chemical damage. Check O-ring chemical compatibility; clean and replace accordingly. Check for excessive system flow rate.
Ball Damaged	Remove and disassemble valve ball. Check for physical damage (excessive nicks, scoring, etc.) at seat sealing surface (perpendicular to ball port). Clean surface; replace ball if necessary. Check for chemical damage and valve material (PVC, CPVC) compatibility.
Solvent-Cement (glue) Contamination from Installation Spillage	Remove valve and check for glue deposits on ball or seat areas. Clean, if possible; excessive damage may require component replacement.
Thermal Damage (component distortion)	Check system operating temperatures, external heat sources (including direct sun), and heat generated from system design or valve placement.

#### Frozen Movements — unable, or very difficult, to open/close; sometimes accompanied by stem break (shear)

Possible Cause	Corrective Action
Internal Obstructions; Sediment or Particle Buildup; Solvent Cement on Ball	Remove valve and check for solids, debris or solvent cement deposits blocking the ball or valve interior. Check for sediment particles lodged around ball-to-seat contact areas. Remove stem and check for the same. Clean and reinstall.
Over-tight Seal Carrier	True-Union Valves - remove valve; slightly loosen seal carrier (located on inlet end of body). Single Entry Valves - slightly loosen single Union Nut. IMPORTANT: Generally only a slight adjustment is required (either valve). A properly adjusted valve should have significant resistance to operation without binding.
Chemical Attack (generally appears as distortion, peeling, etching or bleaching of ball sealing surfaces or other internal components)	Check valve material (PVC, CPVC) chemical compatibility with system fluids. Be sure to consider operating temperatures with this determination.



Thermoplastic Valves Product Guide & Engineering Specifications  
**Ball Valve Troubleshooting Guide**



<b>Structural Breakage</b>		
<b>Location</b>	<b>Possible Cause</b>	<b>Corrective Action</b>
Handle broken	Frozen movements. External impact.	See "Frozen Movements" section. Replace. Identify and correct source.
Handle Stripped	Overextending open/close range. Excessive exposure to direct-sunlight has softened handle material.	Replace handle. Shield or screen valve from direct-sun exposure.
Stem Sheared / Broken	Frozen movements; external impact.	See "Frozen Movements" section.
Broken Union Nut	Nut has been over tightened to draw-up or align end-connectors; external impact.  Inadequate valve supports.  Excessive internal pressure / Hydraulic Shock	Adjust spacing between end-connectors for proper valve lay-lengths. Check system alignment - end connector(s) must be parallel.  Provide system support on each side of valve.  Check system pressures and surge pressures; check for entrapped air.
End Connector Break	System misalignment; external impact.  Over-tighten thread-joint connection.  Inadequate valve support.	Check system alignment - end connector(s) must be parallel.  Install new end connector according to installation instructions.  Provide system support on each side of valve.
Body Break	External impact.  Excessive internal pressure.  System misalignment.  Inadequate valve support.  Chemical attack.	Identify and correct source.  Check system pressures and surge pressures; check for entrapped air.  Check system alignment - end connector(s) must be parallel.  Provide system support on each side of valve.  Check chemical compatibility of system fluids.



**NOTES:** Certain corrective actions of this guide may not be feasible with the Compact Ball Valve (sealed unit).

Improper system operating temperatures and chemical incompatibility can cause a variety of functional and structural failures. Be sure to use proper valve material-types for both temperature and chemical resistance.

Most valve problems are traceable to improper system design or installation. Be sure to have all design performed by a qualified Engineer and installation made by properly trained personnel.

Spears® valve Installation Instructions and Maintenance/Service Procedures should be followed in conjunction with all corrective actions.



## Thermoplastic Valves Product Guide & Engineering Specifications

### Lab Ball Valves



### Features – PVC, CPVC

This versatile quarter-turn shutoff valve is ideally suited for a variety of laboratory, system monitoring and OEM applications. Available in IPS sizes 1/4" - 3/8" with socket or threaded end connectors, plus 1/4" threaded Valve & Adapter Kit to provide multiple connection options.

- Chemical & Corrosion Resistant PVC or CPVC Construction
- Maintenance-Free Sealed Unit
- Individual Valve or Multi-functional Valve & Adapter Kit
- Schedule 80 Full-Bore Design
- High Impact Polypropylene Handle
- EPDM or FKM O-rings
- PTFE Floating Seat Design
- Sizes 1/4" - 3/8" Pressure Rated to 150 psi @ 73°F
- EPDM Valves NSF® Certified for Potable Water use
- Assembled with Silicone-Free, Water Soluble Lubricant

### Sample Engineering Specification

All thermoplastic valves shall be sealed unit Lab type constructed from PVC Type I, ASTM D 1784 Cell Classification 12454 or CPVC Type IV, ASTM D 1784 Cell Classification 23447. All O-rings shall be EPDM or FKM. All valves shall have double stop Polypropylene handle. All 1/4" valves shall have optional field installable male thread and tubing end connector adapters. All EPDM valves shall be certified by NSF International for use in potable water service. All EPDM valves shall be pressure rated at 150 psi for water at 73°F, as manufactured by Spears® Manufacturing Company.

### Quick-View Valve Selection Chart

Valve Size	O-ring Material	PVC Part Number <sup>1,2</sup>			Pressure Rating
		Socket	Threaded	Threaded with Kit	
1/4	EPDM	1522-002	1521-002	1529-002	150 psi Non-Shock Water @ 73°F
	FKM	1532-002	1531-002	1539-002	
3/8	EPDM	1522-003	1521-003	N/A	
	FKM	1532-003	1531-003	N/A	

1: For CPVC Valves, add the letter "C" to part number listed (e.g., 1521-002C)  
 2: For valves with 1/4" I.D. tubing adapters, add the letter "A" to the part number listed (e.g., 1529-002A)



LAB BALL VALVE WITH ADAPTER KIT

### Valve & Adapter Kit

Kit allows multiple connection options. Adapters use O-ring seals for easy connection to threaded valve. Complete Kit includes:

- 1 – Threaded 1/4" Valve
- 2 – O-ring Sealed 1/4" MPT x Mipt Adapters
- 2 – EPDM or FKM O-rings (AS568-013 size)
- 1 – End Connector Wrench
  
- 2 – O-ring Sealed 1/4" MPT x 3/8" I.D. Tubing Barb Adapters - OR -
- 2 – O-ring Sealed 1/4" MPT x 1/4" I.D. Tubing Barb Adapters (Must Add "A" to Valve/Kit Part No.)

### Lab Ball Valve Adapter Kit Only

Valve Size	O-ring Material	Part Number	
		PVC	CPVC
1/4	EPDM	LVKE-002	LVKE-002C
	FKM	LVKV-002	LVKV-002C

- Kit Includes:**
- 2 – O-rings
  - 1 – End Connector Wrench
  - 2 – 1/4" MPT x Mipt Adapters
  - 2 – 1/4" MPT x 3/8" I.D. Tubing Barb Adapters

# Lab Ball Valves

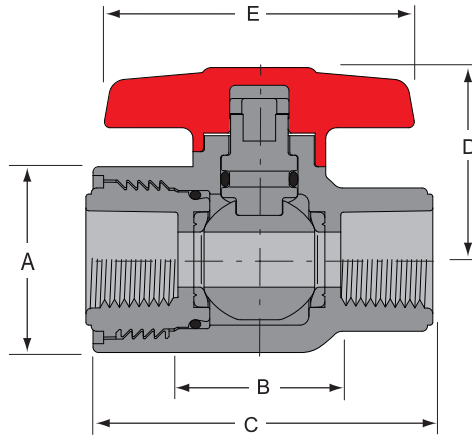

Basic Valve

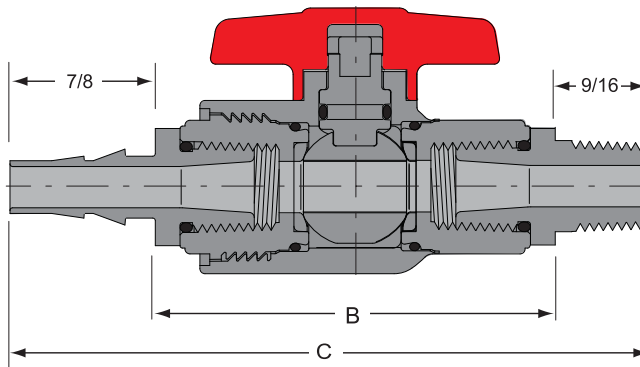

Valve with Adapter Kit

## Dimensions, Weights & Cv Values

Nominal Size	Dimension Reference (inches, ± 1/16)					Approx. Wt. (Lbs.)		C <sub>v</sub> <sup>2</sup> Values
	A	B <sup>1</sup>	C	D	E	PVC	CPVC	
1/4	1-1/16	15/16	2-1/8	1-1/16	1-3/4	.10	.11	10
1/4 w/Kit	1-1/16	2-7/16	3-7/8	1-1/16	1-3/4	.14	.15	6
3/8	1-5/16	1	2-3/16	1-1/4	2	.12	.13	24

1: Valve Lay Length

2: Gallons per minute at 1 psi pressure drop. Values calculated from valve laying length, based on derivative of Hazen-Williams equation with roughness factor of C=150.

## Temperature Pressure Rating

System Operating Temperature °F (°C)		73 (23)	100 (38)	110 (43)	120 (49)	130 (54)	140 (60)	150 (66)	160 (71)	170 (77)	180 (82)	190 (88)
Valve Pressure Rating psi (MPa)	PVC	150 (1.03)	124 (.85)	100 (.69)	75 (.52)	-0- (-0-)	-0- (-0-)	-0- (-0-)	-0- (-0-)	-0- (-0-)	-0- (-0-)	-0- (-0-)
	CPVC	150 (1.03)	140 (.97)	130 (.90)	120 (.83)	110 (.76)	100 (.69)	90 (.62)	80 (.55)	70 (.48)	60 (.41)	-0- (-0-)



## Thermoplastic Valves Product Guide & Engineering Specifications

### Needle Valves



### Features – PVC, CPVC & PP

Needle Valves provide proportional opening to needle travel for more accurate metering applications and other fine adjustment flow control applications. Special design PTFE seal eliminates elastomer type seals or O-rings that can contribute to chemical compatibility problems. PVC, CPVC and Polypropylene valves are available with 1/4", 3/8" and 1/2" NPT female threaded ends in either standard Globe Pattern or special Angle Pattern configuration that eliminates need for additional elbow in various system setups.

- Chemical & Corrosion Resistant PVC, CPVC or PP Construction
- Precision Metering Chamber
- Globe & Angle Body Configurations
- Removable Bonnet For Easy Disassembly & Cleaning
- Solid PTFE Stem Seal - No Elastomer Seal or Lubricants Used
- Built-in Panel or Bracket Mounting Nut
- Easy-Grip Polypropylene Handle
- PVC & CPVC Pressure Rated to 235 psi @ 73°F  
Polypropylene Pressure Rated to 150 psi @ 73°F

### Sample Engineering Specification

All thermoplastic Needle Valves shall be constructed from PVC, ASTM D 1784 Cell Classification 12454, CPVC, ASTM D 1784 Cell Classification 23447, or Polypropylene, ASTM D 4101. All valves shall be globe pattern or angle pattern body configuration with 1/4", 3/8" or 1/2" female NPT end connections. All valves shall have removable bonnet cap with replaceable PTFE seal. No elastomer seals shall be used. All valves shall have built-in panel mounting nut and high impact polypropylene handles. All PVC and CPVC valves shall be pressure rated to 235 psi and all Polypropylene valves to 150 psi for water @ 73°F, as manufactured by Spears® Manufacturing Company.

### Cv Values

Size	Globe Pattern	Angle Pattern
1/4" - 3/8"	.310	.426
1/2"	.62	.78

Gallons per minute at 1 psi pressure drop.

### Quick-View Needle Valve Selection Chart

Valve Size	PVC Part Numbers <sup>1,2</sup>						Pressure Rating
	Globe Pattern			Angle Pattern			
	Socket	SR Threaded	Threaded	Socket	SR Threaded	Threaded	
1/4"	5592-002	N/A	5591-002	5692-002	N/A	5691-002	PVC & CPVC 235 psi, PP 150 psi Non-Shock Water @ 73°F
3/8"	5592-003	5591-003SR	5591-003	5692-003	N/A	5691-003	
1/2"	5592-005	5591-005SR	5591-005	5692-005	5691-005SR	5691-005	

1: For CPVC Valve, add the letter "C" to the part number (e.g. 5591-002C)

2: For threaded Polypropylene Valve, add the letter "P" to the part number (e.g. 5591-002P, 5591-005PSR)

### Temperature Pressure Rating

System Operating Temperature °F (°C)		100 (38)	110 (43)	120 (49)	130 (54)	140 (60)	150 (66)	160 (71)	170 (77)	180 (82)	190 (88)	200 (93)	210 (99)	
Valve Pressure Rating psi (MPa)	1/4"-1/2"	PVC	235 (1.62)	211 (1.45)	150 (1.03)	75 (.52)	50 (.34)	-0- (-0-)	-0- (-0-)	-0- (-0-)	-0- (-0-)	-0- (-0-)	-0- (-0-)	
		CPVC	235 (1.62)	219 (1.51)	170 (1.17)	145 (1.00)	130 (.90)	110 (.76)	90 (.62)	80 (.55)	70 (.48)	60 (.41)	50 (.34)	-0- (-0-)
		PP	150	105	90	80	65	50	45	30	20	-0-	-0-	-0-



### Panel Mounting Instructions

Spears® Needle Valves may be easily mounted to panel or bracket ranging from 3/16" to 1/2" in thickness using the accompanying template. Prepare mounting hole to panel opening dimensions. Slots may be cut in various positions to allow more versatile orientation. Open valve partially. Remove Bonnet Cap with needle assembly (do not fully disassemble) and Panel Nut from valve body. Insert valve body through mounting hole and seat lugs. Reinstall Panel Nut and tighten snug. Carefully reinstall Bonnet Cap and needle assembly, tighten snug. **Caution:** Failure to partially open the valve or back the needle off prior to re-assembly may damage needle when tightening Bonnet Cap.

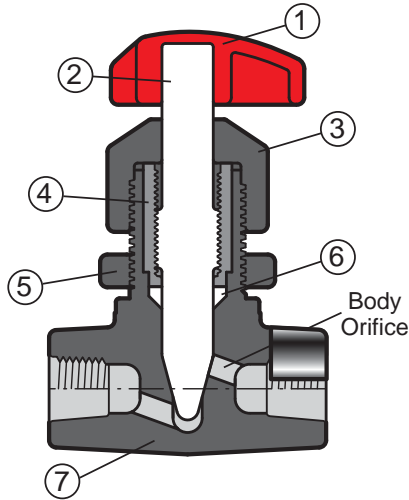

### Replacement Parts

No.	Component	Qty.	Material
1	Handle	1	PP
2	Needle Stem	1	PVC/CPVC/PP
3	Bonnet Cap	1	PVC/CPVC/PP
4	Stem Nut	1	GFPP
5	Panel Nut	1	PVC/CPVC/PP
6	Seal	1	PTFE
7	Body	1	PVC/CPVC/PP

### Body Orifice Dimensions

Valve Size	Body Orifice Ø
1/4	3/16"
3/8	3/16"
1/2	1/4"

### Panel Opening

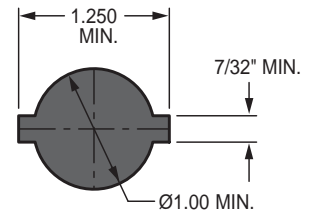

### Globe Pattern

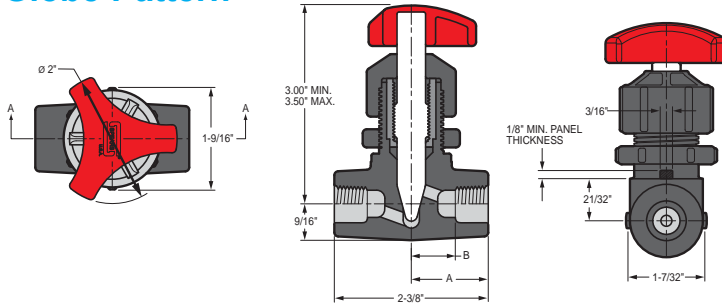

### Dimensions

Valve Size	End Connection	A	B
1/4	Threaded	1-3/16	21/32
	Socket		9/16
3/8	Threaded		9/16
	Socket		7/16
1/2	Threaded	1-3/8	21/32
	Socket		1/2

Threaded Valve Dimensions apply to both Standard and SR Threads.

### Angle Pattern

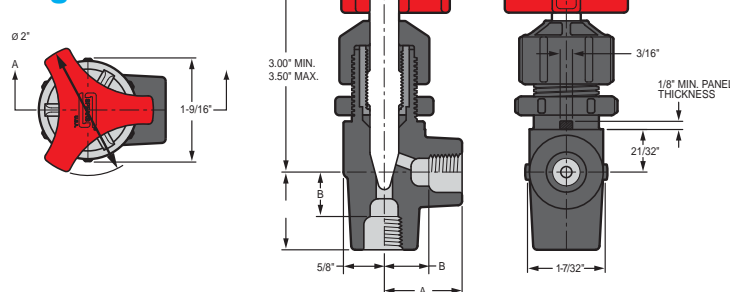

### Needle Valve Adapter Kit

Valve Size	O-ring Material	Part Number	
		PVC	CPVC
1/4	EPDM	LVKE-002	LVKE-002C
	FKM	LVKV-002	LVKV-002C

#### Kit Includes:

- 2 – O-rings
- 1 – End Connector Wrench
- 2 – 1/4" MPT x Mipt Adapters
- 2 – 1/4" MPT x 3/8" I.D. Tubing Barb Adapters



## Plug Gate Valves



### Sample Engineering Specification

All thermoplastic valves shall be Plug Gate style constructed from PVC Type I, ASTM D 1784 Cell Classification 12454 or CPVC Type IV, ASTM D 1784 Cell Classification 23447, with Polypropylene bonnets and high impact Polypropylene hand wheel. All valves shall have non-rising stem and Plug-style Polyethylene gate with Strain-Equalizing thread. All valve components shall be replaceable. All 1/2" - 2" valves shall be pressure rated to 235 psi and all flanged valves 1/2" - 8" to 150 psi for water @ 73°F, as manufactured by Spears® Manufacturing Company.

### Quick-View Valve Selection Chart

Valve Size	O-ring Material	PVC Part Numbers <sup>1</sup>			Pressure Rating
		Socket	SR Threaded	Flanged	
1/2	Buna-N	5212-005	5211-005SR	5213-005	235 psi Non-Shock Water @ 73°F  (Flanged 150 psi Non-Shock Water @ 73°F)
	EPDM	5222-005	5221-005SR	5223-005	
	FKM	5232-005	5231-005SR	5233-005	
3/4	Buna-N	5212-007	5211-007SR	5213-007	
	EPDM	5222-007	5221-007SR	5223-007	
	FKM	5232-007	5231-007SR	5233-007	
1	Buna-N	5212-010	5211-010SR	5213-010	
	EPDM	5222-010	5221-010SR	5223-010	
	FKM	5232-010	5231-010SR	5233-010	
1-1/4	Buna-N	5212-012	5211-012SR	5213-012	
	EPDM	5222-012	5221-012SR	5223-012	
	FKM	5232-012	5231-012SR	5233-012	
1-1/2	Buna-N	5212-015	5211-015SR	5213-015	
	EPDM	5222-015	5221-015SR	5223-015	
	FKM	5232-015	5231-015SR	5233-015	
2	Buna-N	5212-020	5211-020SR	5213-020	
	EPDM	5222-020	5221-020SR	5223-020	
	FKM	5232-020	5231-020SR	5233-020	
6	EPDM	---	---	5223-060	
	FKM	---	---	5233-060	
8	EPDM	---	---	5223-080	
	FKM	---	---	5233-080	

<sup>1</sup>: For CPVC valves, add the letter "C" to the part number (e.g; 5222-005C, 5211-005CSR)

### Features – PVC, CPVC

Spears® Plug Gate Valve utilizes a cylindrical “plug-style” gate for more uniform sealing and positive shutoff. Low-profile, compact design and non-rising stem saves space for the most demanding applications. Spears® Strain-Equalizing stem/wedge design combined with improved Polypropylene bonnet makes this one of the most reliable thermoplastic gate valves available. Valves are produced from PVC or CPVC bodies in IPS sizes of 1/2" - 2" with Socket & SR Threaded or 1/2" - 8" Flanged end connections.

- Chemical & Corrosion Resistant PVC or CPVC Construction with Polypropylene Bonnet
- Polyethylene Plug-Style Gate Provides Cylindrical Internal Seal
- Non-Rising Stem with Patented Strain-Equalizing Threads
- 6" and 8" Valves Features Built-in Position Indicator
- High-Impact Polypropylene Hand Wheel
- Fully Serviceable In-line with Repair Kits or Full Internal Replacement Cartridges
- Buna-N, EPDM or FKM O-ring Seals
- Sizes 1/2" – 2" Pressure Rated to 235 psi @ 73°F Flanged through 8" to 150 psi @ 73°F
- Suitable for Vacuum Service
- Assembled with Silicone-Free, Water Soluble Lubricants
- Optional 2" Square/T-Style Operator Nut available.

### Plug Gate Valve O-ring Repair Kit

All kits include Stem O-ring (2), Bonnet O-ring (1).

Valve Size	Part Number		
	Buna-N O-ring	EPDM O-ring	FKM O-ring
1/2, 3/4 & 1	PGT-BRK-010	PGT-ERK-010	PGT-VRK-010
1-1/4, 1-1/2 & 2	PGT-BRK-020	PGT-ERK-020	PGT-VRK-020
6	---	PGT-ERK-060	PGT-VRK-060
8	---	PGT-ERK-080	PGT-VRK-080

### Plug Gate Valve Internal Replacement Cartridge

Internal Replacement Cartridge includes complete, fully assembled Handle Nut, Stem O-ring, Bonnet O-ring, and Gate for direct insertion into existing valve body.

Valve Size	Part Number					
	Buna-N O-rings	CPVC w/ Buna-N O-rings	EPDM O-rings	CPVC w/ EPDM O-rings	FKM O-rings	CPVC w/ FKM O-rings
1/2, 3/4 & 1	5210-010	5210-010C	5220-010	5220-010C	5230-010	5230-010C
1-1/4, 1-1/2 & 2	5210-020	5210-020C	5220-020	5220-020C	5230-020	5230-020C
6	---	---	5220-060	5220-060C	5230-060	5230-060C
8	---	---	5220-080	5220-080C	5230-080	5230-080C

# Plug Gate Valves

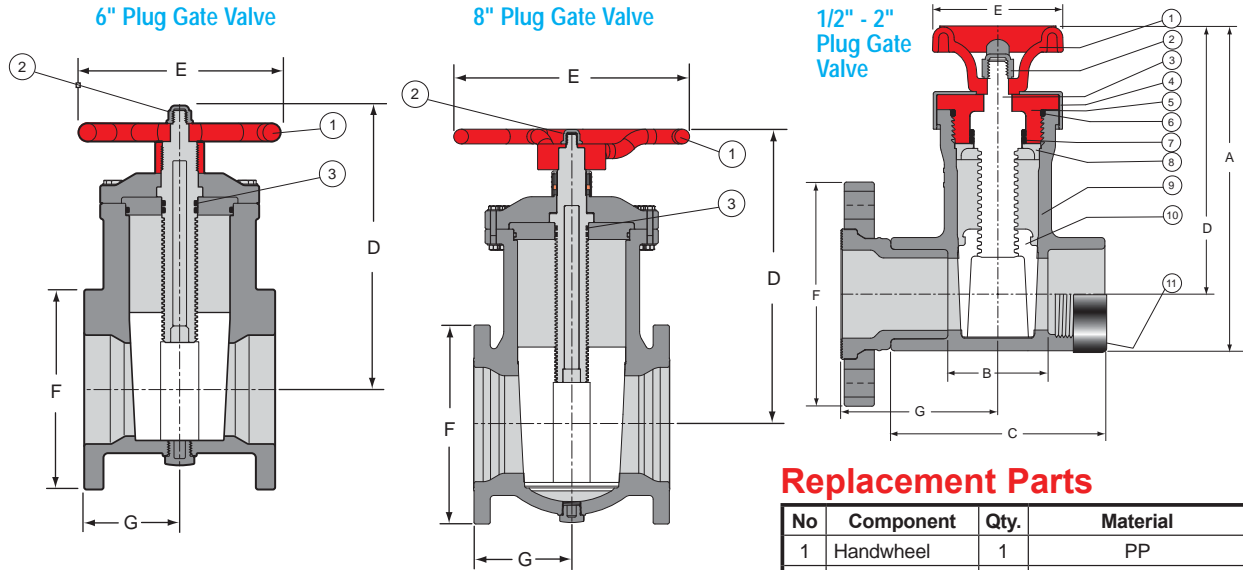

## Replacement Parts

No	Component	Qty.	Material
1	Handwheel	1	PP
2	Nut	1	PVC
3	Stem O-Ring	2	EPDM, FKM

## Replacement Parts

No	Component	Qty.	Material
1	Handwheel	1	PP
2	Nut	1	PVC
3	Stem	1	PP
4	Bonnet Retainer	1	PVC
5	Bonnet	1	PP
6	Bonnet O-ring	1	Buna-N, EPDM, FKM
7	Stem O-ring	2	Buna-N, EPDM, FKM
8	Stem Support	1	PVC/CPVC
9	Body	1	PVC/CPVC
10	Gate	1	PE
11	SS Collar	2	SS 316

## Dimensions & Weights

Nominal Size	Dimension Reference (inches)								Approx. Wt. (Lbs.)			
	A	B		C	D	E	F	G	PVC		CPVC	
		Socket	SR Thread						Soc/Thd	Flanged	Soc/Thd	Flanged
1/2	5	1-1/4	1-11/16	3-1/16	4-1/8	2-5/8	3-1/2	2-11/32	.38	.77	.39	.80
3/4	5	1-1/4	1-15/16	3-5/16	4-1/8	2-5/8	3-7/8	2-1/2	.40	.95	.41	.99
1	5	1-1/4	1-3/4	3-1/2	4-1/8	2-5/8	4-1/4	2-21/32	.43	1.21	.44	1.27
1-1/4	8-5/8	2-21/32	3-7/16	5-1/4	7-1/8	3-7/16	4-5/8	3-5/8	1.84	2.83	1.85	2.89
1-1/2	8-5/8	2-21/32	3-5/8	5-15/32	7-1/8	3-7/16	5	3-15/16	1.94	3.15	1.98	3.27
2	8-5/8	2-21/32	3-27/32	5-23/32	7-1/8	3-7/16	5-15/16	4-5/32	2.11	3.99	2.17	4.18
6	---	---	---	---	15-5/8	10-7/8	11	5-1/4	---	35.53	---	43.56
8	---	---	---	---	20-1/16	16	13-1/2	6-5/8	---	54.59	---	74.55

## Temperature Pressure Rating

System Operating Temperature °F (°C)		100 (38)	110 (43)	120 (49)	130 (54)	140 (60)	150 (66)	160 (71)	170 (77)	180 (82)	190 (88)	200 (93)	210 (99)	
Valve Pressure Rating psi (MPa)	1/2" - 2"	PVC	235 (1.62)	140 (.97)	130 (.90)	90 (.62)	50 (.34)	-0 (-0)	-0 (-0)	-0 (-0)	-0 (-0)	-0 (-0)	-0 (-0)	
		CPVC	235 (1.62)	219 (1.51)	170 (1.17)	145 (1.00)	130 (.90)	110 (.76)	95 (.66)	80 (.55)	70 (.48)	60 (.41)	50 (.34)	-0 (-0)
	6" - 8"	PVC	150 (1.03)	130 (.90)	110 (.76)	60 (.41)	50 (.34)	-0 (-0)	-0 (-0)	-0 (-0)	-0 (-0)	-0 (-0)	-0 (-0)	-0 (-0)
		CPVC	150 (1.03)	140 (.97)	130 (.90)	120 (.83)	110 (.76)	100 (.69)	90 (.62)	80 (.55)	70 (.48)	60 (.41)	50 (.34)	-0 (-0)



## Features – PVC, CPVC

This solid, proven design is well suited for a variety of chemical, industrial and irrigation applications. Spears® Gate Valves are feature-packed with a variety of end connector options. Individual special features are found in each size range 1/2" through 2", 2-1/2" & 3", and in the full featured Heavy Industrial 4" valve. See Spears® Plug Gate Valves for 6" size.

- Heavy Bodied PVC & CPVC Construction
- Tapered Wedge with Specially Designed Sealing Surface
- Non-Rising Stem Design
- Patented Strain-Equalizing Stem/Wedge Thread
- O-ring Stem Seals Instead of Packing - No Retightening Required
- Buna-N, EPDM, or FKM O-ring Seals
- Positive Grip, High Impact Polypropylene Handwheel Operator
- Fully Serviceable, Replaceable Components - Accessible Without Valve Removal
- EPDM Gate Valves NSF® Certified for Potable Water use
- Suitable for Vacuum Service
- Assembled with Silicone-Free, Water Soluble Lubricants
- Metric Socket and BSP Thread Available, 1/2" - 2"



### 1/2" - 2" PVC & CPVC Heavy Duty Gate Valves

- Available with socket, threaded or flanged end connectors.
- Pressure rated to 200 psi @ 73°F. Flanged Valve Pressure Rated to 150 psi @ 73°F

### 2-1/2" & 3" PVC & CPVC Heavy Duty Gate Valves

- Available with socket, SR Threaded (Special Reinforced) threaded or flanged end connectors.
- Pressure rated to 150 psi @ 73°F.
- Optional 2" Square/T-Style Operator Nut available.

**Note:** 2-1/2" size is a bushed down 3" valve.

### 4" PVC & CPVC Heavy Industrial Gate Valves

- Available with socket, SR Threaded (Special Reinforced) threaded or flanged end connectors.
- Pressure rated to 235 psi @ 73°F. Flanged Valve Pressure Rated to 150 psi @ 73°F
- SS 316 Exterior Bonnet & Hardware
- Built-in Quick-View Position Indicator
- Optional 2" Square/T-Style Operator Nut available.

## Sample Engineering Specification

All thermoplastic Gate Valves shall be constructed from PVC Type I Cell Classification 12454 or CPVC Type IV Cell Classification 23447. All O-rings shall be Buna-N, EPDM or FKM. All EPDM valves shall be NSF® certified for potable water use. All valves shall have non-rising stem and Polypropylene handwheel. All valve gate wedges shall have Strain-Equalizing threads. PVC valves shall have Polypropylene wedge and CPVC valves shall have CPVC wedge. All valve components shall be replaceable. All 1/2" through 2" valves shall be pressure rated at 200 psi, all 2-1/2" through 3" and all flanged valves shall be pressure rated at 150 psi, and all 4" valves shall be pressure rated at 235 psi for water at 73°F, as manufactured by Spears® Manufacturing Company.

# Gate Valves



## Quick-View Valve Selection Chart

Valve Size	O-ring Material	PVC Part Numbers <sup>1</sup>			Pressure Rating	
		Socket	Threaded	Flanged		
1/2	Buna-N	2012-005	2011-005	2013-005	200 psi Non-Shock Water @ 73°F	
	EPDM	2022-005	2021-005	2023-005		
	FKM	2032-007	2031-005	2033-005		
3/4	Buna-N	2012-007	2011-007	2013-007		
	EPDM	2022-007	2021-007	2023-007		
	FKM	2032-007	2031-007	2033-007		
1	Buna-N	2012-010	2011-010	2013-010		
	EPDM	2022-010	2021-010	2023-010		
	FKM	2032-010	2031-010	2033-010		
1-1/4	Buna-N	2012-012	2011-012	2013-012		(Flanged 150 psi Non-Shock Water @ 73°F)
	EPDM	2022-012	2021-012	2023-012		
	FKM	2032-012	2031-012	2033-012		
1-1/2	Buna-N	2012-015	2011-015	2013-015		
	EPDM	2022-015	2021-015	2023-015		
	FKM	2032-015	2031-015	2033-015		
2	Buna-N	2012-020	2011-020	2013-020		
	EPDM	2022-020	2021-020	2023-020		
	FKM	2032-020	2031-020	2033-020		
2-1/2	Buna-N	2012-025 <sup>3</sup>	2011-025 <sup>3</sup>	2013-025 <sup>3</sup>	150 psi Non-Shock Water @ 73°F	
	EPDM	2022-025 <sup>3</sup>	2021-025 <sup>3</sup>	2023-025 <sup>3</sup>		
	FKM	2032-025 <sup>3</sup>	2031-025 <sup>3</sup>	2033-025 <sup>3</sup>		
3	Buna-N	2012-030	2011-030SR	2013-030		
	EPDM	2022-030	2021-030SR	2023-030		
	FKM	2032-030	2031-030SR	2033-030		
4	Buna-N	2012-040	2011-040SR	2013-040		235 <sup>2</sup> psi Non-Shock Water @ 73°F
	EPDM	2022-040	2021-040SR	2023-040		
	FKM	2032-040	2031-040SR	2033-040		

- 1: For CPVC valves, add the letter "C" to the part numbers (e.g., 2031-005C).
- 2: Flanged end connectors have a Maximum Internal Pressure Rating of 150 psi @ 73°F.
- 3: Outlet sized with bushing.

## C<sub>v</sub> Values

Nominal Size	C <sub>v</sub> <sup>1</sup> Gallons/Minute	
	Socket/Threaded	Flanged
1/2	19	15
3/4	37	29
1	44	39
1-1/4	128	105
1-1/2	144	127
2	333	279
2-1/2	See Note 2	
3	335	323
4	583	566

- Flanged valves calculated for additional laying length of flanged valve.
- 1: Gallons per minute at 1 psi pressure drop.
- 2: Size 2-1/2" is a reducer bushed down 3" valve, C<sub>v</sub> not available.

## Temperature Pressure Rating

System Operating Temperature °F (°C)		100 (38)	110 (43)	120 (49)	130 (54)	140 (60)	150 (66)	160 (71)	170 (77)	180 (82)	190 (88)	200 (93)	210 (99)	
Valve Pressure Rating psi (MPa)	1/2"-2"	PVC	200 (1.38)	135 (.93)	120 (.83)	75 (.52)	50 (.34)	-0- (-0-)	-0- (-0-)	-0- (-0-)	-0- (-0-)	-0- (-0-)	-0- (-0-)	
		CPVC	200 (1.38)	155 (1.07)	140 (.97)	125 (.86)	110 (.76)	100 (.69)	90 (.62)	80 (.55)	70 (.48)	60 (.41)	50 (.34)	-0- (-0-)
	2-1/2"-3"	PVC	150 (1.03)	130 (.90)	110 (.76)	60 (.41)	50 (.34)	-0- (-0-)	-0- (-0-)	-0- (-0-)	-0- (-0-)	-0- (-0-)	-0- (-0-)	-0- (-0-)
		CPVC	150 (1.03)	140 (.97)	130 (.90)	120 (.83)	110 (.76)	100 (.69)	90 (.62)	80 (.55)	70 (.48)	60 (.41)	50 (.34)	-0- (-0-)
	4"	PVC	235 (1.62)	140 (.97)	130 (.90)	90 (.62)	50 (.34)	-0- (-0-)	-0- (-0-)	-0- (-0-)	-0- (-0-)	-0- (-0-)	-0- (-0-)	-0- (-0-)
		CPVC	235 (1.62)	219 (1.51)	170 (1.17)	145 (1.00)	130 (.90)	110 (.76)	95 (.66)	80 (.55)	70 (.48)	60 (.41)	50 (.34)	-0- (-0-)





## Gate Valves

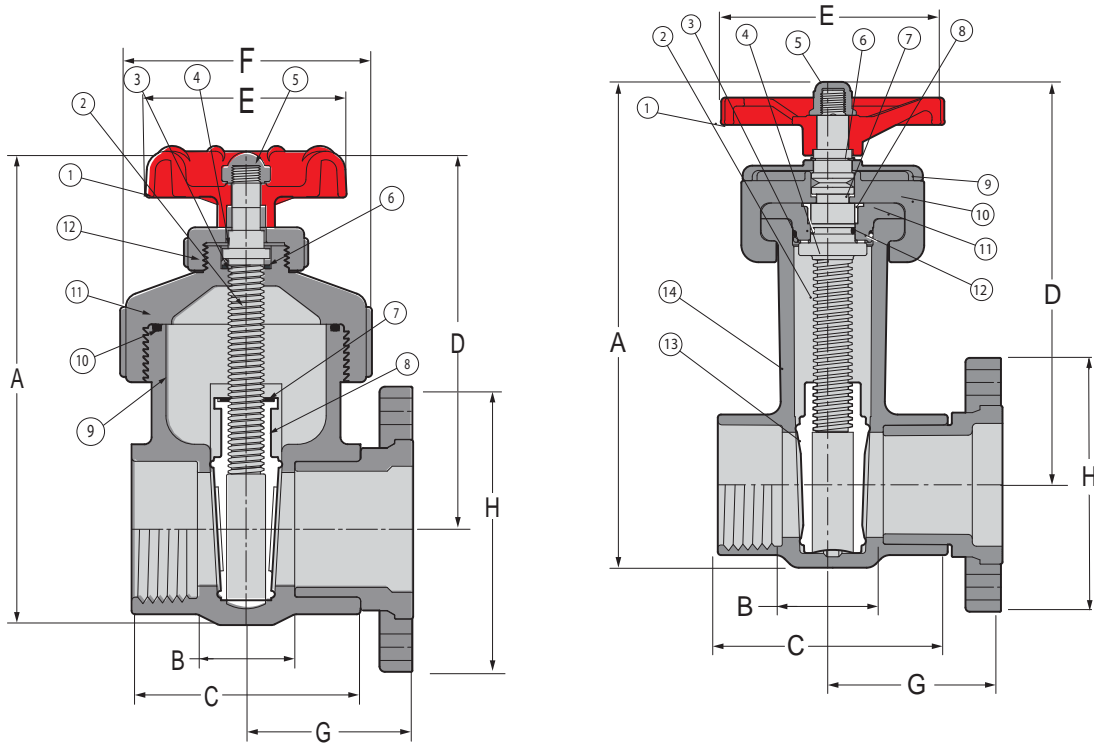

### 1/2" - 2" Replacement Parts

No.	Component	Qty.	Material
1	Handle	1	PP
2	Stem	1	PVC/CPVC
3	Stem O-ring	1	Buna-N/EPDM/FKM
4	Stem Bushing	1	PP
5	Stem Nut	1	PVC/CPVC
6	Stem Washer	1	PP
7	Wedge Washer/O-ring	1	Buna-N/EPDM/FKM
8	Wedge	1	PP/CPVC
9	Body (Socket/Threaded)	1	PVC/CPVC
10	Bonnet O-ring	1	Buna-N/EPDM/FKM
11	Bonnet	1	PVC/CPVC
12	Bonnet Nut	1	PVC/CPVC

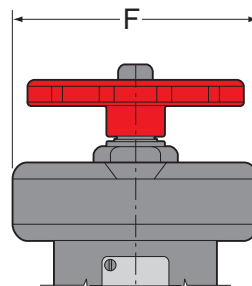

### 2-1/2" & 3" Replacement Parts

No.	Component	Qty.	Material
1	Handle	1	PP
2	Stem	1	PVC/CPVC
3	Stem Bearing	1	PP
4	Stem O-ring	1	Buna-N/EPDM/FKM
5	Stem Nut	1	PVC
6	Stem Retaining Ring	1	SS 316
7	Split Washer	1	PP
8	Stem Bushing	1	PP
9	Bonnet Retainer	1	PVC/CPVC
10	Bonnet Half	2	PVC/CPVC
11	Seal Carrier	1	PVC/CPVC
12	Carrier O-ring	1	Buna-N/EPDM/FKM
13	Wedge	1	PP/CPVC
14	Body	1	PVC/CPVC

# Gate Valves

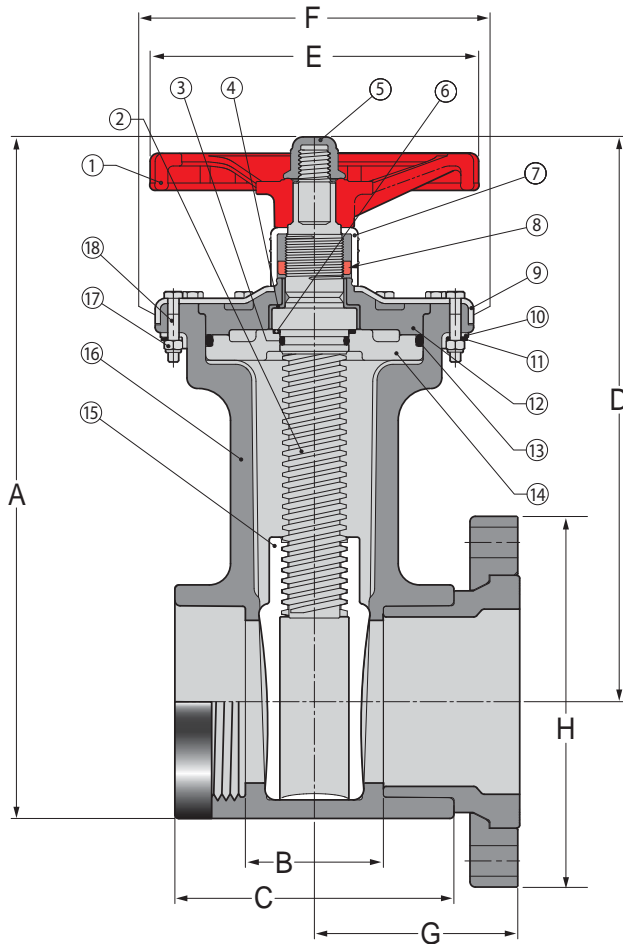

## 4" Replacement Parts

No.	Component	Qty.	Material
1	Handle	1	PP
2	Stem	1	PVC/CPVC
3	Stem O-ring	1	Buna-N/EPDM/FKM
4	Stem Bushing	1	PTFE/HDPE
5	Stem Nut	1	PVC/CPVC
6	Stem Washer	1	PP
7	Indicator Cover	1	PVC Clear
8	Indicator Nut	1	PP Yellow
9	Bonnet Retainer	1	SS 316
10	Retainer Bracket	2	SS 316
11	Bracket Lock	1	SS 316
12	Bonnet	1	PVC/CPVC
13	Seal Carrier O-ring	1	Buna-N/EPDM/FKM
14	Seal Carrier	1	PVC/CPVC
15	Wedge	1	PP/CPVC
16	Body	1	PVC/CPVC
17	Locknut	12	SS 316
18	Hex Bolt	12	SS 316

## Dimensions & Weights

Nominal Size	Dimension Reference (inches, ± 1/16)								Approx. Wt. (Lbs.)			
	A	B <sup>1</sup>	C	D	E	F	G	H	PVC		CPVC	
									Soc/Thd	Flanged	Soc/Thd	Flanged
1/2	5-1/8	1-1/4	2-13/16	4-1/8	2-5/8	2-11/16	2-3/8	3-1/2	.51	.92	.56	.98
3/4	5-1/8	1-1/4	2-13/16	4-1/8	2-5/8	2-11/16	2-1/2	3-7/8	.52	1.09	.57	1.16
1	5-13/32	1-1/4	3-5/16	4-5/16	2-5/8	2-15/16	2-3/4	4-1/4	.67	1.46	.73	1.54
1-1/4	8-1/16	1-9/16	3-9/16	6-9/16	3-7/16	3-15/16	3-1/16	4-5/8	1.61	2.58	1.73	2.74
1-1/2	8-1/16	1-9/16	3-3/4	6-9/16	3-7/16	3-15/16	3-7/16	5	1.63	2.81	1.75	3.03
2	8-9/16	1-11/16	3-15/16	6-7/8	3-7/16	4-7/16	3-5/8	6	1.95	3.81	2.15	4.09
2-1/2	14-5/16	3-3/8	7-3/8	11-7/8	6-11/16	7-1/4	5-1/8	7	9.48	11.91	9.60	12.89
3	14-5/16	2-15/16	6-11/16	11-7/8	6-11/16	7-1/4	4-15/16	7-1/2	9.03	12.21	9.43	13.40
4	16	3-3/8	7-15/16	13-1/4	8	7-9/16	4-7/8	9	13.67	18.39	14.66	19.75

1: Valve Lay Length



## 2" Square / T-Style Operator Nuts

- Fits Spears® Gate Valves.
- Combination design for use with either standard 2" square drive or conventional "T" drive operators.

Size	Part Number
1/2, 3/4, 1	GTN-005
1-1/4, 1-1/2, 2	GTN-012
2-1/2 & 3	GTN-030
4	GTN-040



## Globe Valves



### Features - PVC, CPVC

Spears® Globe Valves provide close throttling control throughout the entire range of operation through positive shutoff. This makes the Globe Valve an excellent choice for throttling applications where pressure drop is not critical. Valves are available in PVC and CPVC materials in larger IPS sizes of 2-1/2" through 6" with Flanged end connections.

- Excellent Throttling Characteristics
- Chemical & Corrosion Resistant PVC or CPVC Construction – No Wetted Metal Parts
- Fully Serviceable In-line with Factory Assembled Internal Repair Kit
- Buna-N, EPDM or FKM Seat & Seals
- Sizes 2-1/2" – 6" Pressure Rated to 150 psi @ 73°F
- Suitable for Vacuum Service
- Assembled with Silicone-Free, Water Soluble Lubricants

### Sample Engineering Specification

All thermoplastic Globe valves shall be constructed from PVC Type I, ASTM D 1784 Cell Classification 12454 or CPVC Type IV, ASTM D 1784 Cell Classification 23447. All seals shall be Buna-N, EPDM or FKM. All valves shall have a high impact polypropylene handwheel. All PVC and CPVC 2-1/2" through 6" valves shall be pressure rated to 150 psi for water at 73°F, as manufactured by Spears® Manufacturing Company.

### Quick-View Valve Selection Chart

Valve Size	Seals	PVC Part Numbers <sup>1</sup>	Pressure Rating
		Flanged	
2-1/2	Buna-N <sup>2</sup>	6013-025	150 psi Non-Shock Water @ 73°F
	EPDM	6023-025	
	FKM	6033-025	
3	Buna-N <sup>2</sup>	6013-030	
	EPDM	6023-030	
	FKM	6033-030	
4	Buna-N <sup>2</sup>	6013-040	
	EPDM	6023-040	
	FKM	6033-040	
6	Buna-N <sup>2</sup>	6013-060	
	EPDM	6023-060	
	FKM	6033-060	

1: For CPVC Globe Valves, add the letter "C" to the part number listed (e.g. 6023-025C).  
2: Valves with Buna-N seals available in PVC only.

### Globe Valve Internal Repair Kit

Internal Repair Kit includes: Bonnet O-ring (1) along with a factory assembled (required) internal component replacement unit consisting of Bonnet assembled with Stem O-rings, Seat and Seal Carrier components. Install in valve using existing valve Bolts, Nuts, Washers and Handle Nut.

Valve Size	Part Number				
	Buna-N O-ring	EPDM O-ring	CPVC w/EPDM O-ring	FKM O-ring	CPVC w/FKM O-ring
2-1/2	GL-BRK-025	GL-ERK-025	GL-ERK-025C	GL-VRK-025	GL-VRK-025C
3	GL-BRK-030	GL-ERK-030	GL-ERK-030C	GL-VRK-030	GL-VRK-030C
4	GL-BRK-040	GL-ERK-040	GL-ERK-040C	GL-VRK-040	GL-VRK-040C
6	GL-BRK-060	GL-ERK-060	GL-ERK-060C	GL-VRK-060	GL-VRK-060C

# Globe Valves

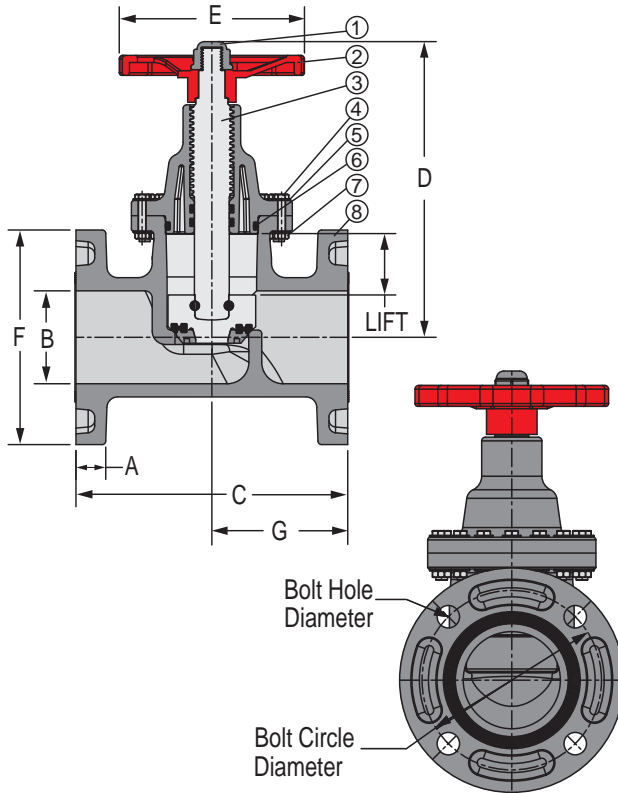

## Replacement Parts

NO.	COMPONENT	QTY.	MATERIAL
1	Handle Nut	1	PVC
2	Handle	1	PP
3	Stem Assembly <sup>1</sup>	1	PVC/CPVC; BUNA-N/EPDM/FKM
4	Hex Bolt	1	SS 316
5	Flat Washer	1	SS 316
6	Bonnet O-ring	1	BUNA-N/EPDM/FKM
7	Hex Nut	1	SS 316
8	Body	1	PVC/CPVC

<sup>1</sup> - Stem Assembly Includes: Stem (1), Bonnet (1), Stem O-rings (2), Dowel Pins (2), Dowel Pin Plugs (2), Seal Carrier (1), Seat (1), Seat Retainer (1)

## C<sub>v</sub> Values

Nominal Size	C <sub>v</sub> 1
2-1/2	62
3	85
4	125
6	221

<sup>1</sup>: Gallons per minute at 1 psi pressure drop.

## Dimensions

Nominal Size	A	B	C	D (Open)	E	F	G	LIFT	Bolt Circle Diameter	Bolt Hole Diameter	Number of Bolt Holes
2-1/2	1-1/16	3-1/4	9-1/2	12-1/2	6-9/16	7-1/2	4-3/4	2-1/8	5-1/2	3/4	4
3	1-1/16	3-1/4	9-1/2	12-1/2	6-9/16	7-1/2	4-3/4	2-1/8	6	3/4	4
4	1-1/8	4-1/4	11-1/2	13-1/4	11	9	5-3/4	2-3/16	7-1/2	3/4	8
6	1-1/4	6-5/16	16-1/4	17-7/8	11	11	8-1/8	3-1/4	9-1/2	7/8	8

## Temperature Pressure Rating

System Operating Temperature °F (°C)		73 (23)	100 (38)	110 (43)	120 (49)	130 (54)	140 (60)	150 (66)	160 (71)	170 (77)	180 (82)	190 (88)
Valve Pressure Rating psi (MPa)	PVC	150 (1.03)	124 (.85)	100 (.69)	75 (.52)	-0- (-0-)	-0- (-0-)	-0- (-0-)	-0- (-0-)	-0- (-0-)	-0- (-0-)	-0- (-0-)
	CPVC	150 (1.03)	140 (.97)	130 (.90)	120 (.83)	110 (.76)	100 (.69)	90 (.62)	80 (.55)	70 (.48)	60 (.41)	-0- (-0-)





## Y-Pattern Valves



### Features - PVC Gray, PVC Clear & CPVC

The Y-Pattern valve is a closing-down, globe type valve design that provides proportional opening to seating disc travel. As such, Y-Pattern valves are ideally suited for flow regulating applications. The Y-pattern configuration reduces pressure loss over that of standard globe valves. Available in IPS Sizes 1/2" - 4" with socket, SR threaded, flanged, socket union or SR threaded union end connectors.

### Sample Engineering Specification

All thermoplastic valves shall be Y-Pattern configuration constructed from PVC, ASTM D 1784 Cell Classification 12454, or CPVC, ASTM D 1784 Cell Classification 23447. All valves shall have Buttress thread bonnet and standard O-ring type seating disc. All O-rings shall be EPDM or FKM. All valves shall have high impact polypropylene handles. All 1/2" - 2" valves shall be pressure rated at 150 psi for water at 73°F, as manufactured by Spears® Manufacturing Company.

- Chemical & Corrosion Resistant PVC Gray, PVC Clear or CPVC Construction
- Buttress Thread Bonnet
- Fully Serviceable, Replaceable Components
- Standard O-ring Seal Seating Disc & Seals
- EPDM or FKM O-rings
- High Impact Polypropylene Handle
- Assembled with Silicone-Free, Water Soluble Lubricants
- Sizes 1/2" - 2" Pressure Rated to 150 psi @ 73°F, Sizes 3" - 4" Pressure Rated to 90 psi @ 73°F

### Quick-View Valve Selection Chart

Valve Size	O-ring Material	PVC Material <sup>1,2,3</sup>					Pressure Rating	
		Socket	SR Threaded	Flanged	Socket Union	SR Threaded Union		
1/2	EPDM	1722-005	1721-005SR	1723-005	172A-005	172B-005SR	150 psi Non-Shock Water @73°F	
	FKM	1732-005	1731-005SR	1733-005	173A-005	173B-005SR		
3/4	EPDM	1722-007	1721-007SR	1723-007	172A-007	172B-007SR		
	FKM	1732-007	1731-007SR	1733-007	173A-007	173B-007SR		
1	EPDM	1722-010	1721-010SR	1723-010	172A-010	172B-010SR		
	FKM	1732-010	1731-010SR	1733-010	173A-010	173B-010SR		
1-1/4	EPDM	1722-012	1721-012SR	1723-012	172A-012	172B-012SR		
	FKM	1732-012	1731-012SR	1733-012	173A-012	173B-012SR		
1-1/2	EPDM	1722-015	1721-015SR	1723-015	172A-015	172B-015SR		
	FKM	1732-015	1731-015SR	1733-015	173A-015	173B-015SR		
2	EPDM	1722-020	1721-020SR	1723-020	172A-020	172B-020SR		90 psi Non-Shock Water @73°F
	FKM	1732-020	1731-020SR	1733-020	173A-020	173B-020SR		
3	EPDM	1722-030	1721-030SR	1723-030	172A-030	172B-030SR		
	FKM	1732-030	1731-030SR	1733-030	173A-030	173B-030SR		
4	EPDM	1722-040	1721-040SR	1723-040	172A-040	172B-040SR		
	FKM	1732-040	1731-040SR	1733-040	173A-040	173B-040SR		

1: For CPVC Y-Pattern, add the letter "C" to the part number (e.g. 1722-005C)  
 2: For PVC Clear Y-Pattern, add the letters "CL" to the part number (e.g. 1722-005CL) or (e.g. 172A-005CL)  
 3: For CPVC or Clear Special Reinforced Y-Pattern, (e.g. 1721-005CSR) or (e.g. 1721-005CLSR)

### Replacement Parts

NO.	COMPONENT	QTY.	MATERIAL
1	Body <sup>1</sup> (SOC/SR/FLG/UNION)	1	PVC/CLEAR/CPVC
2	Stem Assembly	1	PVC/CPVC;EPDM/FKM
3	Seal Carrier O-ring	1	EPDM/FKM
4	Bonnet Nut	1	PVC/CPVC
5	Bonnet	1	PVC/CPVC
6	Handwheel	1	PP
7	Stem Nut	1	PVC
8	Union O-ring	2	EPDM/FKM
9	Union Socket End	2	PVC/CPVC
10	Union SR Thread End	2	PVC/CPVC

1 - SR-Fipt Body Includes: Body (1), Spigot Adapters (2), SS Collars (2)  
 - Flange Body Includes: Body (1), Spigot Hubs (2), Flange Rings (2)  
 - Union Body Includes: Body (1), Spigot Ends (2), Nuts (2)  
 2 - Stem Assembly Includes: Stem (1), Seat Retainer (1), Seat Plate (1), Seat (1), Seal Carrier (1), Retainer Plate (1) (Except 4"), Stem O-ring (1)

### Temperature Pressure Rating

System Operating Temperature °F (°C)		100 (38)	110 (43)	120 (49)	130 (54)	140 (60)	150 (66)	160 (71)	170 (77)	180 (82)	190 (88)	200 (93)	210 (99)
Valve Pressure Rating psi (MPa)	1/2" - 2"	PVC	150 (1.03)	135 (.93)	110 (.76)	75 (.52)	50 (.34)	-0-	-0-	-0-	-0-	-0-	-0-
		CPVC	150 (1.03)	140 (.97)	130 (.90)	120 (.83)	110 (.76)	100 (.70)	90 (.62)	80 (.55)	70 (.48)	60 (.41)	50 (.34)
	3" - 4"	PVC	90 (.70)	85 (.62)	75 (.52)	60 (.41)	40 (.30)	-0-	-0-	-0-	-0-	-0-	-0-
		CPVC	90 (.70)	85 (.62)	80 (.55)	75 (.52)	70 (.48)	60 (.41)	50 (.34)	45 (.31)	40 (.30)	35 (.24)	30 (.21)

### C<sub>v</sub> Values

Size	Values
1/2	6.7
3/4	12.6
1	22.9
1-1/4	33.8
1-1/2	50.7
2	79.2
3	235
4	387

# Y-Pattern Valves

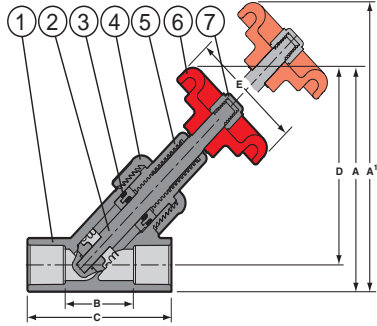

## Socket Y-Pattern Dimensions & Weights

Nominal Size	Dimension Reference (inches, ± 1/16)						Approx. Wt. (Lbs.)	
	A <sup>1</sup>	A	B	C	D	E	Socket	
							PVC	CPVC
1/2	6-3/8	4-9/16	1-5/8	3-3/8	4	2-3/8	.31	.33
3/4	7-1/2	5-1/4	2	4	4-9/16	2-3/8	.50	.53
1	6-15/16	5-7/8	2-1/2	4-3/4	5-1/8	2-3/8	.78	.90
1-1/4	10-15/16	7-5/8	3-1/16	5-9/16	6-1/2	3-1/2	1.21	1.28
1-1/2	12	8-5/8	3-9/16	6-5/16	7-1/2	3-1/2	1.66	1.76
2	13-13/16	9-15/16	4-1/2	7-1/2	8-1/2	3-1/2	2.96	3.10
3	20	14-1/2	6-9/16	10-5/16	12-7/16	6-5/8	5.34	5.64
4	25-1/2	18-1/4	8-5/8	13-1/8	15-5/8	7-15/16	9.97	10.45

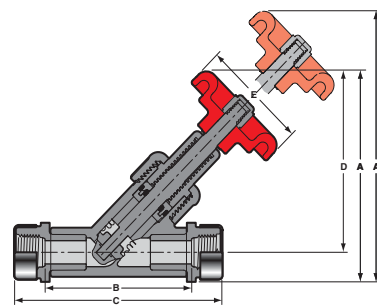

## SR Threaded Y-Pattern Dimensions & Weights

Nominal Size	Dimension Reference (inches, ± 1/16)						Approx. Wt. (Lbs.)	
	A <sup>1</sup>	A	B	C	D	E	SR Threaded	
							PVC	CPVC
1/2	6-1/2	4-11/16	3-5/8	5-1/16	4	2-3/8	.31	.33
3/4	7-5/8	5-7/16	4-3/8	5-13/16	4-9/16	2-3/8	.50	.53
1	8-5/8	6-1/8	5-3/16	7	5-1/8	2-3/8	.85	.90
1-1/4	11-1/8	7-3/4	6	7-15/16	6-1/2	3-1/2	1.21	1.28
1-1/2	12-1/4	8-7/8	6-15/16	8-13/16	7-1/2	3-1/2	1.66	1.76
2	14-1/16	10-3/16	8-1/8	10-1/8	8-1/2	3-1/2	2.96	3.10
3	20	14-13/16	11	14-1/4	12-7/16	6-5/8	5.34	5.64
4	25-13/16	18-1/2	14	14-3/4	15-5/8	7-15/16	9.97	10.45

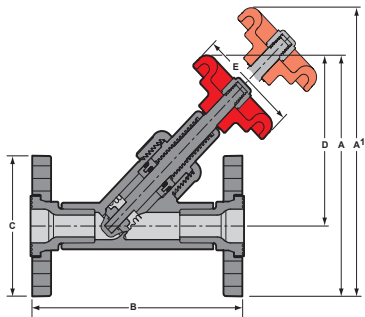

## Flanged Y-Pattern Dimensions & Weights

Nominal Size	Dimension Reference (inches, ± 1/16)						Approx. Wt. (Lbs.)	
	A <sup>1</sup>	A	B	C	D	E	Flanged	
							PVC	CPVC
1/2	7-9/16	5-3/4	5-11/16	3-1/2	4	2-3/8	.82	.85
3/4	8-3/4	6-1/2	6-7/16	3-7/8	4-9/16	2-3/8	1.23	1.28
1	9-3/4	7-1/4	7-1/4	4-1/4	5-1/8	2-3/8	1.70	1.81
1-1/4	12-1/4	8-7/8	8-1/8	4-5/8	6-1/2	3-1/2	2.40	2.52
1-1/2	13-3/8	10	9-3/16	5	7-1/2	3-1/2	3.07	3.25
2	15-3/8	11-1/2	10-3/8	6	8-1/2	3-1/2	5.20	5.42
3	21-11/16	16-3/16	12-1/16	7-1/2	12-7/16	6-5/8	9.44	10.07
4	27-7/16	20-3/16	14-9/16	9-1/16	15-5/8	7-15/16	14.87	16.15

Note: 4" flanged Y-Pattern use split flange ring

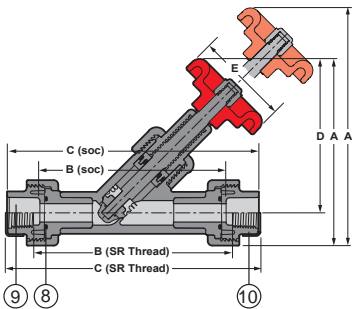

## True Union Y-Pattern Dimensions & Weights

Nominal Size	Dimension Reference (inches, ± 1/16)						Approx. Wt. (Lbs.)			
	A <sup>1</sup>	A	B		C		D	E	Union	
			Socket	SR Thread	Socket	SR Thread			PVC	CPVC
1/2	7	5-3/16	5-1/8	5-1/2	6-7/8	7	4-1/4	2-5/8	.59	.62
3/4	8-3/16	6	5-7/8	6-7/16	7-7/8	7-7/8	4-7/8	2-5/8	.97	1.02
1	9-1/8	6-5/8	6-1/2	7-3/8	8-3/4	9	5-3/8	2-5/8	1.33	1.41
1-1/4	11-1/2	8-3/16	7-7/16	6-3/16	9-15/16	10-1/8	6-5/8	3-1/2	1.53	1.63
1-1/2	12-13/16	9-3/8	8-3/16	9	10-15/16	10-15/16	7-9/16	3-1/2	3.06	3.25
2	14-9/16	10-11/16	9-7/16	10-13/16	12-7/16	12-13/16	8-5/8	3-1/2	4.90	5.16
3	21-1/8	15-5/8	13-5/8	15-3/8	17-3/8	18-3/16	12-1/2	6-5/8	14.06	14.37
4	25	19-7/16	17-1/16	19-1/4	21-5/8	22-5/16	7-15/16	7-15/16	17.39	19.23



## Innovation, Versatility & High Performance Technology



Spears® innovative design departs from traditional liner-seat type valves to eliminate seat creep, reduce operating torque and provide positive seal off. Ideally suited for flow control or throttling, this high performance valve is offered with a full variety of options for greater application versatility. Standard valves are produced from PVC or high temperature CPVC in IPS sizes 1-1/2" through 14". PVC and CPVC True Lug valves are produced in sizes 1-1/2" through 12".

### Special Offset Disc

Lifts quickly from single contact sealing surface to reduce seat wear and lower operating torque, with bubble-tight seal off. Suitable for vacuum service.

### Limited Contact Interference Seat Design

Sealing contact between disc and seat takes place only at close of valve, allowing free travel through full range of valve opening. Eliminates seat creep, extrusion and wear typical with conventional liner-type seats. Exclusive design interlocks seat and body to prevent wash-out or blow-out.

### Field Replaceable Seat — Choice of Buna-N, FKM, or NSF® Certified EPDM

Replace seat without full valve disassembly using convenient Seat & Seal Carrier Replacement Kit or Full Valve Overhaul Kit. Choice of Buna-N, EPDM or FKM seats and seals. EPDM valves are NSF® Certified for use with potable water.

### Solid, Chemical & Corrosion Resistant

#### 316 Stainless Steel Stem — Fully Isolated

Heavy blow-out proof 316 stainless steel stem is standard on all valves. Fully isolated (dry stem) eliminates contact with process fluid.

### Rugged PVC or CPVC Body & Disc

Computer engineered design places strength where needed most. PVC or high temperature handling CPVC materials provide exceptional chemical and corrosion resistance. Integrally molded actuation mounting pad and lug receptacles for field installable lug sets.

### Full 150 psi Pressure Rating

Pressure rated to a maximum internal pressure of 150 psi at 73°F — including Dead-End Service.

### Low Profile Cast Aluminum Gear Operator

Standard on 10" and larger sizes, utilizes high efficiency worm gear drive, with high impact polypropylene handwheel and built-in position indicator. Available as an option on smaller valves. Special order gear operators available for a variety of submersible and other environmental applications.

### Field Installable Lug Inserts or Factory

#### Installed True Lug Valves (Sizes 1-1/2" - 12")

Standard valve body accepts optional field installable lug insert sets for easy single-sided installation and system add-on. True Lug valve comes with factory installed lugs for total versatility, including disconnection from either side while under pressure. Both styles suitable for full pressure dead-end service. Choice of stainless or zinc plated steel lugs.

### Exclusive Factory Reconditioning Program

Spears® will factory recondition originally purchased Butterfly Valve to full working order — regardless of condition. Contact Spears® Technical Services Department for details and pricing.

### High Impact Polypropylene Lever Handle

Standard on 1-1/2" through 8" sizes, provides quick selection from any one of seven stop positions, with built-in lockout capability. Reversible 180° for either right or left side operation.

### Polypropylene & PTFE Lined Valves

High performance Butterfly Valves are available in Polypropylene 1-1/2" through 60". See publication PPBFV-2 for additional details. Plus, unique PTFE lined valve design custom manufactured for high purity systems. Contact Spears® Technical Services for additional information.

### Sample Engineering Specification

All thermoplastic valves shall be Butterfly type constructed from PVC Type I Cell Classification 12454 or CPVC Type IV Cell Classification 23447. All valve seats and O-rings shall be Buna-N, EPDM or FKM. Seat shall be a non-liner type interlocked to valve body. Bolt hole patterns shall conform to ANSI/ASME B-16.5 CL 150. Disc shall be offset design with Type 316 stainless steel stem. Lever operated valves shall be equipped with high impact polypropylene handle having built-in lockout capability. Gear operated valves shall be equipped with position indicator and high impact polypropylene handwheel. Valves through size 12" shall accept field installable lug inserts or shall be factory installed True Lug type. Lugs shall be stainless steel or zinc plated steel. Valves shall be pressure rated at 150 psi for water at 73°F, as manufactured by Spears® Manufacturing Company.



### Basic Valve Options

Butterfly Valves can be purchased with any combination of the following options:

- Lever Handle Valve (through 8" only)
- Gear Operated Valve
- Valve Only (no handle/operator)
- True Lug Valves
  - Stainless Steel
  - Zinc Plated Steel
- Buna-N Seats
- EPDM Seats
- FKM Seats
- PTFE Sleeved Seats

### Valve Repair & Accessory Kits

- Lever Handle Kits
- Gear Operator Kits
- Chainwheel Operator Kits
- Lug Insert Sets (for standard valve)
  - Stainless Steel
  - Zinc Plated Steel
- 2" Square / T-Style Gear Operator Nuts
- Seat & Seal Carrier Replacement Kits
- Valve Overhaul Kits
- Stem Extension Kits

### Cv Values & Operating Torque

Valve Size	Cv Degrees Open						Operating Torque (in.-lbs.)
	15°	30°	45°	60°	75°	90°	
1-1/2	2	8	20	36	61	81	100
2	3	11	27	49	82	109	110
2-1/2	5	19	48	86	144	192	206
3	9	35	86	155	259	345	360
4	10	41	103	185	308	411	420
6	28	113	281	506	844	1125	720
8	56	225	562	1012	1687	2249	1200
10	111	444	1110	1998	3330	4440	1320
12	158	631	1577	2839	4732	6309	1920
14	176	705	1762	3172	5286	7048	See Note

**NOTE:** Operating torque for large diameter valves varies significantly with system operating pressure, flow direction and velocity. Contact Spears® for torque requirement based on application.

SPEARS® Butterfly Valves are designed for installation with user supplied full-face, 1/8" thick Neoprene (or desired elastomer) gaskets, hex bolts, nuts, and washers. True Lug Valves may be installed for flow in either direction. Standard Valves may be installed for flow in either direction in a dual flange (flange each side) installation, but require attention to direction of flow when installed in a single-side (flange one-side only) application for dead-end service. Consult installation instructions for details of single-side installation and special instructions for use of lug-insert option.

### General Conformance Specifications

**Material** — ASTM D 1784 (PVC Cell Classification 12454, CPVC Cell Classification 23447); Certified by NSF International for potable water service.

**Bolt Hole Pattern** — ANSI/ASME B-16.5; ASTM D 4024

**Laying Length (Standard valve ONLY)** — AWWA C504 (wafer valve); MSS SP-67

**Pressure Class** — 150B, AWWA C504

**Hydrostatic Pressure Test** — AWWA C504, ASTM D 1599

SUITABILITY OF VALVE AND VALVE COMPONENTS FOR APPLICATION AND OPERATING ENVIRONMENT IS AT USER'S DISCRETION AND RESPONSIBILITY.





## Thermoplastic Valves Product Guide & Engineering Specifications

### Wafer Butterfly Valves



### Sample Engineering Specification

All thermoplastic valves shall be Wafer Butterfly type constructed from PVC Type I Cell Classification 12454 or CPVC Type IV Cell Classification 23447. All valve seats and O-rings shall be Buna-N, EPDM or FKM. Seat shall be a non-liner type mounted to the valve disc. All valves shall have built-in Santoprene™ Thermoplastic Elastomer (TFE) flange gaskets. Wafer style valves shall be for mounting between two flanges having bolt hole pattern that conform to ANSI/ASME B16.5 CL 150. Disc shall be centered with Type 316L Stainless Steel Stem. Stem shall be isolated from the process medium for dry operation. Lever operated valves shall be equipped with high impact polypropylene handle having 7-position stops and built-in lockout capability. Gear operated valves shall be equipped with position indicator and high impact polypropylene handwheel. Valves shall be pressure rated at 150 psi for water at 73°F, as manufactured by Spears® Manufacturing Company.

### PVC Quick-View Valve Selection Chart

Valve Size	O-ring Material	STANDARD VALVE DESIGN			Pressure Rating
		PVC Part Number <sup>1</sup>			
		w/Lever Handle	w/Gear Operator	Valve Only	
2	Buna-N	751311-020	751321-020	751301-020	150 psi Non-Shock Water @ 73°F
	EPDM	752311-020	752321-020	752301-020	
	FKM	753311-020	753321-020	753301-020	
2-1/2	Buna-N	751311-025	751321-025	751301-020	
	EPDM	752311-025	752321-025	752301-025	
	FKM	753311-025	753321-025	753301-025	
3	Buna-N	751311-030	751321-030	751301-030	
	EPDM	752311-030	752321-030	752301-030	
	FKM	753311-030	753321-030	753301-030	
4	Buna-N	751311-040	751321-040	751301-040	
	EPDM	752311-040	752321-040	752301-040	
	FKM	753311-040	753321-040	753301-040	
6	Buna-N	751311-060	751321-060	751301-060	
	EPDM	752311-060	752321-060	752301-060	
	FKM	753311-060	753321-060	753301-060	
8	Buna-N	751311-080	751321-080	751301-080	
	EPDM	752311-080	752321-080	752301-080	
	FKM	753311-080	753321-080	753301-080	
10	Buna-N	751311-100	751321-100	751301-100	
	EPDM	752311-100	752321-100	752301-100	
	FKM	753311-100	753321-100	753301-100	
12	Buna-N	751311-120	751321-120	751301-120	
	EPDM	752311-120	752321-120	752301-120	
	FKM	753311-120	753321-120	753301-120	

<sup>1</sup>: For CPVC EPDM & FKM valves, add the letter "C" to part numbers listed (e.g., 752311-030C).

### Features - PVC, CPVC

Spears® Wafer Butterfly Valve is a multi-featured design incorporating laying lengths that allow direct replacement of common Cast Iron valves such as Keystone Model 228 and Bray Series 30 Butterfly Valves. Wafer Valves feature built-in Santoprene™ Thermoplastic Elastomer (TPE) flange gaskets, easy operating disc-mounted seat, and fully isolated stem design. Available in sizes 2" through 12", with choice of Buna-N, EPDM or FKM Seats on PVC Valves, EPDM or FKM on CPVC Valves.

- Chemical & Corrosion Resistant PVC or CPVC Construction
- Special Designed Laying Lengths for Direct Replacement of Common Cast Iron Butterfly Valves
- Built-in Santoprene™ Thermoplastic Elastomer (TPE) Gaskets on Valve Flange Faces
- Easy Operating Disc Mounted Seat in Choice of Buna-N, EPDM, or FKM
- Fully Isolated (Dry) Solid Type 316L Stainless Steel Stem
- Reversible High Impact Polypropylene Lever Handle with 7-Position Stops and Built-in Lockout Capability
- Optional High Efficiency Gear Operator with Cast Aluminum Housing, Polypropylene Handwheel and Built-in Position Indicator
- Compatible with ANSI/ASME B16.5 Class 150 Bolt Pattern Flanges
- Pressure Rated to 150 psi for water @ 73°F (23°C)

### General Installation Information

Spears® Wafer Butterfly Valves are designed for system connections between two flanges having ANSI B16.5 Class 150 bolt hole patterns. The valve handle (or gear operator) is reversible 180° for either left or right side operation. Wafer Butterfly Valves have built-in flange gaskets and are designed for installation with user supplied hex bolts, nuts and flat washers. The valve must be positioned with gasket areas evenly located between mating flange sealing surfaces. Valve Bolt Specification bolt lengths in table below are minimums based on use of two (2) Spears® flanges, Valve with built-in gaskets, standard S.A.E. hex bolts and Standard Plate "W" Series flat washers.

**Caution:** Spears® Wafer Butterfly Valves are designed for use with flanges or flanged equipment having minimum waterway inside diameter no less than that of Schedule 80 PVC pipe (ASTM D 1785). *Use of smaller inside diameter flange connections may result in obstruction and damage to the valve disc and seat.*

# Wafer Butterfly Valves

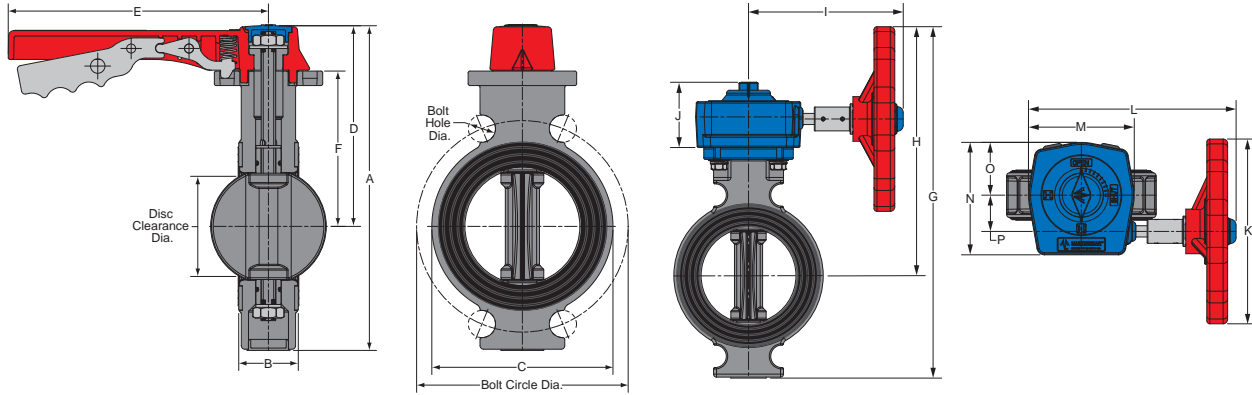

## PVC & CPVC Wafer Butterfly Valve Bolt Specifications & Dimensions

Valve Size	Bolt Diameter (in.)	Bolt Length (in.)	No. of Bolt Holes
2	5/8	4-1/2	4
2-1/2	5/8	5	4
3	5/8	5	4
4	5/8	5-1/2	8
6	3/4	6	8
8	3/4	6-1/2	8
10	7/8	7	12
12	7/8	7-1/2	12

Size	A	B	C	D	E	F	Bolt Circle Diameter <sup>2</sup>			No. of Bolts <sup>3</sup>	Bolt Hole Dia.	Disc Clearance Dia.
							ANSI	PN16 (mm)	PN10 ISO DIN (mm)			
2	8-5/8	1-11/16	3-3/4	5-9/16	9	4	4-3/4	125	125	4	13/16	1-1/2
2-1/2	9-5/8	1-13/16	4-1/2	6-1/16	9	4-1/2	5-1/2	145	145	4	13/16	1-15/16
3	10-1/8	1-13/16	5	6-7/16	9	4-7/8	6	NA	NA	4	7/8	2-3/4
4	11-13/16	2-1/16	6-1/4	6-15/16	9	5-3/8	7-1/2	180	180	4 (8)	15/16	3-7/16
6	14-7/8	2-3/16	8-9/16	9-3/8	11-7/8	7-1/8	9-1/2	240	240	4 (8)	7/8	5-7/16
8	17-7/16	2-9/16	10-3/4	10-5/8	13-13/16	8-7/16	11-3/4	NA	295	4 (8)	15/16	7-3/16
10 <sup>1</sup>	NA	2-9/16	12-7/8	NA	NA	10-11/16	14-1/4	355	350	4 (12)	1-1/8	9-3/16
12 <sup>1</sup>	NA	3-1/16	15-9/16	NA	NA	11-11/16	17	410	400	4 (12)	1-1/2	11-1/8

1: 10" and 12" valves are only available with gear operator.

2: Holes are oversized to accommodate different bolt patterns — ASME/ANSI B16.1 – Cast Iron Pipe Flanges and Flanged Fittings - Class 150 Bolt Patterns; PN10 & PN16 = B54504 – Circular Flanges for Pipes, Valves and Fittings (PN - Designated); DIN = DIN8063 Part 4 – Pipe Joint Assemblies and Fittings for Unplasticized Polyvinyl Chloride (PVC-U) Pressure Pipe.

3: Valve is positioned with 4 of 8 required Flange Bolts in sizes 4 to 8 inches and 4 of 12 in sizes 10 and 12 inches.

Size	G	H	I	J	K	L	M	N	O	P
2	12-1/4	9-1/8	6-1/2	2-3/4	8	8-3/4	4-1/2	4-3/4	2-1/4	1-1/2
2-1/2	13-1/8	9-1/2	6-1/2	2-3/4	8	8-3/4	4-1/2	4-3/4	2-1/4	1-1/2
3	13-5/8	10	6-1/2	2-3/4	8	8-3/4	4-1/2	4-3/4	2-1/4	1-1/2
4	14-3/4	10-1/2	6-1/2	2-3/4	8	8-3/4	4-1/2	4-3/4	2-1/4	1-1/2
6	17-3/4	12-1/4	6-1/2	2-3/4	8	8-3/4	4-1/2	4-3/4	2-1/4	1-1/2
8	20-3/8	13-1/2	6-1/2	2-3/4	8	8-3/4	4-1/2	4-3/4	2-1/4	1-1/2
10	24	15-7/8	6-3/4	3	8	9-1/4	5-1/8	5-7/8	2-1/2	2-1/8
12	26-3/8	16-7/8	6-3/4	3	8	9-1/4	5-1/8	5-7/8	2-1/2	2-1/8

## Temperature Pressure Rating

System Operating Temperature °F (°C)		100 (38)	110 (43)	120 (49)	130 (54)	140 (60)	150 (66)	160 (71)	170 (77)	180 (82)	190 (88)	200 (93)	210 (99)
Valve Pressure Rating psi (MPa)	PVC	150 (1.03)	135 (.93)	110 (.76)	75 (.52)	50 (.34)	-0- (-0-)	-0- (-0-)	-0- (-0-)	-0- (-0-)	-0- (-0-)	-0- (-0-)	-0- (-0-)
	CPVC	150 (1.03)	140 (.97)	130 (.90)	120 (.83)	110 (.76)	100 (.70)	90 (.62)	80 (.55)	70 (.48)	60 (.41)	50 (.34)	-0- (-0-)





## Thermoplastic Valves Product Guide & Engineering Specifications

### Butterfly Valves - Standard, Lug Insert & True-Lug Styles

#### Standard & True Lug Design



Lever Handle



True Lug



Gear Operating



Lug Insert Style



14" Standard  
PVC & CPVC  
Butterfly Valves

#### Features - PVC, CPVC

Spears® patented Butterfly Valve design departs from traditional liner-seat type valve to eliminate seat creep, reduce operating torque and provide positive seal-off. Ideally suited for flow control or throttling, this high-performance valve is offered with a full variety of options for greater application versatility in industrial and chemical processing applications. Available in IPS sizes 1-1/2" - 14" in Standard or 1-1/2" - 12" True Lug (factory installed lugs) style.

- Special off-set Disc lifts quickly from seat to reduce wear and reduce operating torque.
- Patented Limited Contact Seat design provides free travel - eliminates seat creep, extrusion and wear. Field replaceable without full valve disassembly.
- Interlocking Body & Seat prevents wash-out or blow-out.
- Buna-N, EPDM or FKM Seat & Seals
- Fully Isolated Solid Type 316L Stainless Steel Stem
- Reversible High Impact Polypropylene Lever Handle with 7-Position stops & Built-in Lockout (standard handle on 1-1/2" - 8" valves; not available on 10" & larger valves)
- High Efficiency Gear Operator with Cast Aluminum Housing, Polypropylene Handwheel, and Built-in Position Indicator (available for all sizes; standard on 10" & larger valves)
- Lug Insert Style valve has factory installed SS316 or zinc plated steel lug inserts.
- Standard valve accepts field-installable Lug Inserts Set option
- True Lug design has factory installed zinc plated or SS 316 lugs and is specially designed for connection to either side of valve.
- Pressure Rated to 150 psi @ 73°F including Dead-End Service.
- ANSI/ASME B16.5 Class 150 Bolt Pattern
- Valves with EPDM Seals & Seats are NSF® Certified for Potable water use.

#### Sample Engineering Specification

All thermoplastic valves shall be Butterfly type constructed from PVC Type I Cell Classification 12454 or CPVC Type IV Cell Classification 23447. All valve seats and O-rings shall be Buna-N, EPDM or FKM. Seat shall be a non-liner type interlocked to valve body. Bolt hole patterns shall conform to ANSI/ASME B16.5 Class 150. Disc shall be offset design with fully isolated Type 316L stainless steel stem and Type 316 stainless steel hardware. Lever operated valves shall be equipped with high impact polypropylene handle having built-in lockout capability. Gear operated valves shall be equipped with position indicator and high impact polypropylene handwheel. Valve bodies shall accept field installable lug inserts or shall be factory installed lug inserts, or be True Lug type. Lugs shall be stainless steel or zinc plated steel. Valves shall be pressure rated at 150 psi for water at 73°F through 12", as manufactured by Spears® Manufacturing Company.

#### Optional Accessories

- PTFE Coated Stem
- Stem Extension Kit
- PTFE Seat Sleeve
- Lever Handle Kit (standard on 1-1/2" - 8" valves)
- Gear Operator Kit (standard on 10" & larger valves)
- T-Handle Kit
- Field Installable Lug Insert Sets (for Standard valve)
- Speed Handle (for gear operated valves)
- 2" Square/T-Style Operator Nut (for gear operated valves)
- Chainwheel Operator Kit (for gear operated valves)
- Positive Stem Stop (for gear operated valves)
- Submersible Gear Operators

\* See "BUTTERFLY VALVE ACCESSORIES" section for details of individual products.

## Thermoplastic Valves Product Guide & Engineering Specifications Butterfly Valves - Standard, Lug Insert & True-Lug Styles



### Standard & Lug Insert Style Quick-View Valve Selection Chart

Valve Size	O-ring Material	STANDARD VALVE DESIGN			LUG INSERT VALVE DESIGN			Pressure Rating
		PVC Part Number <sup>1</sup>			PVC Part Number <sup>1</sup> Installed with 316 Stainless Steel Lug Inserts <sup>2,3,4</sup>			
		w/Lever Handle	w/Gear Operator	Valve Only	w/Lever Handle	w/Gear Operator	Valve Only	
1-1/2	Buna-N	721311-015	721321-015	721301-015	721311G-015	721321G-015	721301G-015	150 psi Non-Shock Water @ 73°F
	EPDM	722311-015	722321-015	722301-015	722311G-015	722321G-015	722301G-015	
	FKM	723311-015	723321-015	723301-015	723311G-015	723321G-015	723301G-015	
2	Buna-N	721311-020	721321-020	721301-020	721311G-020	721321G-020	721301G-020	
	EPDM	722311-020	722321-020	722301-020	722311G-020	722321G-020	722301G-020	
	FKM	723311-020	723321-020	723301-020	723311G-020	723321G-020	723301G-020	
2-1/2	Buna-N	721311-025	721321-025	721301-025	721311G-025	721321G-025	721301G-025	
	EPDM	722311-025	722321-025	722301-025	722311G-025	722321G-025	722301G-025	
	FKM	723311-025	723321-025	723301-025	723311G-025	723321G-025	723301G-025	
3	Buna-N	721311-030	721321-030	721301-030	721311G-030	721321G-030	721301G-030	
	EPDM	722311-030	722321-030	722301-030	722311G-030	722321G-030	722301G-030	
	FKM	723311-030	723321-030	723301-030	723311G-030	723321G-030	723301G-030	
4	Buna-N	721311-040	721321-040	721301-040	721311G-040	721321G-040	721301G-040	
	EPDM	722311-040	722321-040	722301-040	722311G-040	722321G-040	722301G-040	
	FKM	723311-040	723321-040	723301-040	723311G-040	723321G-040	723301G-040	
6	Buna-N	721311-060	721321-060	721301-060	721311G-060	721321G-060	721301G-060	
	EPDM	722311-060	722321-060	722301-060	722311G-060	722321G-060	722301G-060	
	FKM	723311-060	723321-060	723301-060	723311G-060	723321G-060	723301G-060	
8	Buna-N	721311-080	721321-080	721301-080	721311G-080	721321G-080	721301G-080	
	EPDM	722311-080	722321-080	722301-080	722311G-080	722321G-080	722301G-080	
	FKM	723311-080	723321-080	723301-080	723311G-080	723321G-080	723301G-080	
10	Buna-N	10" AND LARGER NOT AVAILABLE WITH LEVER HANDLE	721321-100	721301-100	10" AND LARGER NOT AVAILABLE WITH LEVER HANDLE	721321G-100	721301G-100	
	EPDM		722321-100	722301-100		722321G-100	722301G-100	
	FKM		723321-100	723301-100		723321G-100	723301G-100	
12	Buna-N		721321-120	721301-120		721321G-120	721301G-120	
	EPDM		722321-120	722301-120		722321G-120	722301G-120	
	FKM		723321-120	723301-120		723321G-120	723301G-120	
14	EPDM		722321-140	722301-140		--	--	100 psi @ 73°F
	FKM		723321-140	723301-140		--	--	



- 1: For CPVC valves, add the letter "C" to part numbers listed (e.g., 722311C-030C).  
 2: For factory installed Lug Insert Valve with Zinc Plated Lugs, substitute the letter "G" with the letter "K" (e.g. 721311K-030)  
 3: For True Lug Design Valve with Stainless Steel Lugs, substitute the letter "G" with the letter "L" (e.g. 721311L-030).  
 4: For True Lug Design Valve with Zinc Plated Steel Lugs, substitute the letter "G" with the letter "Z" (e.g. 721311Z-030).

**Note:** Optional BFFV with submersible gear operators available, inquire with Spears®.

### Temperature Pressure Rating

System Operating Temperature °F (°C)		100 (38)	110 (43)	120 (49)	130 (54)	140 (60)	150 (66)	160 (71)	170 (77)	180 (82)	190 (88)	200 (93)	210 (99)
Valve Pressure Rating psi (MPa)	PVC	150 (1.03)	135 (.93)	110 (.76)	75 (.52)	50 (.34)	-0- (-0-)	-0- (-0-)	-0- (-0-)	-0- (-0-)	-0- (-0-)	-0- (-0-)	-0- (-0-)
	CPVC	150 (1.03)	140 (.97)	130 (.90)	120 (.83)	110 (.76)	100 (.70)	90 (.62)	80 (.55)	70 (.48)	60 (.41)	50 (.34)	-0- (-0-)

See dimensions and additional Technical Information on following pages



## Polypropylene



### Sample Engineering Specification

All thermoplastic valves shall be Butterfly type constructed from Polypropylene, ASTM D 4101. All valve seats and O-rings shall be Buna-N, EPDM or FKM. Seat shall be a non-liner type interlocked to valve body. Bolt hole pattern shall conform to ANSI/ASME B16.5 Class 150. Disc shall be offset design with fully isolated, Type 316L stainless steel stem and Type 316 stainless steel hardware. Lever operated valves shall be equipped with high impact polypropylene handle having built-in lockout capability. Gear operated valves shall be equipped with position indicator and high impact polypropylene handwheel. Valves shall be pressure rated at [see table] for water at 73°F, as manufactured by Spears® Manufacturing Company.

**Material Note:** UV Stabilized Polypropylene with beige pigment sizes 1-1/2" - 12" are glass reinforced, sizes 14" - 24" are not.

## Features

Spears® patented Butterfly Valve design departs from traditional liner-seat type valve to eliminate seat creep, reduce operating torque and provide positive seal-off. Broad range of chemical resistance makes Polypropylene well suited for industrial and chemical processing applications. Designed for flow control or throttling, this high-performance valve is offered with a full variety of options for greater application versatility. Available in IPS sizes 1-1/2" - 24" with custom produced 30" to 60" valves available.

- UV Stabilized Polypropylene Construction
- Special off-set Disc lifts quickly from seat to reduce wear and reduce operating torque.
- Patented Limited Contact Seat design provides free travel - eliminates seat creep, extrusion and wear. Field replaceable without full valve disassembly.
- Interlocking Body & Seat prevents wash-out or blow-out.
- Buna-N, EPDM or FKM Seat & Seals
- Solid Type 316L Stainless Steel Stem, fully isolated from process fluids
- Reversible High Impact Polypropylene Lever Handle with 7-Position stops & Built-in Lockout (standard handle on 1-1/2" - 8" valves; not available on 10" & larger valves)
- High Efficiency Gear Operator with Cast Aluminum Housing, Polypropylene Handwheel, and Built-in Position Indicator (available for all sizes; standard on 10" & larger valves)
- Pressure ratings include Dead-End Service (See Chart).
- ANSI/ASME B16.5 Class 150 Bolt Pattern

## Optional Accessories

- PTFE Coated Stem
- Stem Extension Kit
- PTFE Seat Sleeve (through 12" size)
- Lever Handle Kit (standard on 1-1/2" - 8" valves)
- Gear Operator Kit (standard on 10" & larger valves)
- T-Handle Kit
- Speed Handle (for gear operated valves)
- 2" Square/T-Style Operator Nut (for gear operated valves)
- Chainwheel Operator Kit (for gear operated valves)
- Positive Stem Stop (for gear operated valves)
- Submersible Gear Operators

\* See "BUTTERFLY VALVE ACCESSORIES" section for details of individual products.

Polypropylene Butterfly Valves



Polypropylene Quick-View Valve Selection Chart

Valve Size	O-ring Material	w/Lever Handle	w/Gear Operator	Valve Only	Pressure Rating
1-1/2	Buna-N	721311-015P	<b>Special Order</b>	721301-015P	150 psi Non-Shock Water @ 73°F
	EPDM	722311-015P	<b>Special Order</b>	722301-015P	
	FKM	723311-015P	<b>Special Order</b>	723301-015P	
2	Buna-N	721311-020P	721321-020P	721301-020P	
	EPDM	722311-020P	722321-020P	722301-020P	
	FKM	723311-020P	723321-020P	723301-020P	
2-1/2	Buna-N	721311-025P	721321-025P	721301-025P	
	EPDM	722311-025P	722321-025P	722301-025P	
	FKM	723311-025P	723321-025P	723301-025P	
3	Buna-N	721311-030P	721321-030P	721301-030P	
	EPDM	722311-030P	722321-030P	722301-030P	
	FKM	723311-030P	723321-030P	723301-030P	
4	Buna-N	721311-040P	721321-040P	721301-040P	
	EPDM	722311-040P	722321-040P	722301-040P	
	FKM	723311-040P	723321-040P	723301-040P	
6	Buna-N	721311-060P	721321-060P	721301-060P	
	EPDM	722311-060P	722321-060P	722301-060P	
	FKM	723311-060P	723321-060P	723301-060P	
8	Buna-N	721311-080P	721321-080P	721301-080P	
	EPDM	722311-080P	722321-080P	722301-080P	
	FKM	723311-080P	723321-080P	723301-080P	
10	Buna-N	10" and Larger not available with Lever Handle	721321-100P	721301-100P	
	EPDM		722321-100P	722301-100P	
	FKM		723321-100P	723301-100P	
12	Buna-N		721321-120P	721301-120P	
	EPDM		722321-120P	722301-120P	
	FKM		723321-120P	723301-120P	
14	Buna-N		---	---	
	EPDM		722321-140P	722301-140P	
	FKM		723321-140P	723301-140P	
16	Buna-N		---	---	
	EPDM		722321-160P	722301-160P	
	FKM		723321-160P	723301-160P	
18	Buna-N		---	---	
	EPDM		722321-180P	722301-180P	
	FKM		723321-180P	723301-180P	
20	Buna-N		---	---	
	EPDM		722321-200P	722301-200P	
	FKM		723321-200P	723301-200P	
24	Buna-N		---	---	
	EPDM		722321-240P	722301-240P	
	FKM		723321-240P	723301-240P	

Note: 30" - 60" Polypropylene Butterfly Valves produced to order



Temperature Pressure Rating

System Operating Temperature °F (°C)	100 (38)	110 (43)	120 (49)	130 (54)	140 (60)	150 (66)	160 (71)	170 (77)	180 (82)	190 (88)	
Valve Pressure Rating psi (MPa)	1-1/2"-12"	150 (1.03)	105 (.72)	90 (.62)	80 (.55)	65 (.45)	50 (.34)	45 (.31)	30 (.21)	20 (.14)	-0-
	14"	100 (.69)	70 (.48)	60 (.41)	53 (.37)	43 (.26)	33 (.23)	30 (.21)	20 (.14)	13 (.09)	-0-
	16"	85 (.59)	60 (.41)	51 (.35)	45 (.31)	37 (.26)	28 (.19)	26 (.18)	17 (.12)	11 (.08)	-0-
	18"	70 (.48)	49 (.34)	42 (.29)	37 (.26)	30 (.21)	23 (.16)	21 (.14)	14 (.10)	9 (.06)	-0-
	20"-24"	50 (.34)	35 (.24)	30 (.21)	27 (.19)	22 (.15)	17 (.12)	15 (.10)	10 (.07)	7 (.05)	-0-



## Thermoplastic Valves Product Guide & Engineering Specifications

### High Purity Butterfly Valves

### High Purity TFM Lined



#### Features - CPVC

This advanced technology TFM Lined valve is specially designed and produced for applications requiring high purity and maximum chemical resistance. Spears® exclusive component-interface seal fully isolates process media to disc and liner contact only. Custom produced in sizes 2" through 6".

- Direct disc-to-liner seal between ECTFE fluoropolymer disc and TFM liner for positive shut-off. Specially designed offset disc lifts quickly from sealing surface to minimize wear and reduce operating torque.
  - Special disc-to-liner interface isolates valve components from process media. Eliminates stem and elastomer backing seal contact with process fluids. In the unlikely event of seal failure, leakage is expelled externally to protect process integrity. TFM skirt is integrally formed as part of the liner to isolate the CPVC body.
  - Solid, fully isolated type 316 stainless steel stem is additionally PTFE coated as a safeguard.
  - Lug style, chemical and corrosion resistant CPVC body features integrally molded actuation mounting pad and provides increased temperature handling capability to 200°F.
- 316 stainless steel Lug Inserts provide quick single-side valve installation and easy system add-on.
  - Low Profile Gear Operator features high efficiency worm gear drive with built-in position indicator and high impact polypropylene handwheel. Operator housing is powder coated for improved cleanliness. Reversible for either right or left side operation.
  - 150 psi Maximum Internal Pressure rating at 73°F.

#### Sample Engineering Specification

All thermoplastic Butterfly Valves shall be constructed from CPVC Type IV Cell Classification 23447 with TFM liner and ECTFE disc. Disc and liner interface shall isolate valve components and elastomeric seals from process media. Valve Stem shall be PTFE coated type 316 stainless steel. Body shall be lug style with 18-8 stainless steel or type 316 stainless steel lugs. Bolt hole patterns shall conform to ANSI/ASME B16.5 Class 150. Valve shall be gear operated with powder coated operator housing, position indicator, and high impact polypropylene handwheel. Valve shall be pressure rated at 150 psi for water at 73°F, as manufactured by Spears® Manufacturing Company.

#### Factory Reconditioning

In the event of damage, this maintenance-free valve can be factory reconditioned in order to maintain optimum serviceability and assure proper component isolation function. Valve reconditioning is made on an exchange basis with original limited warranty. Contact Spears® Technical Services for additional information.

#### Material Specifications

##### Media Contact Components:

- Liner/seat** TFM (Hostafion® — modified - PTFE)
- Disc** ECTFE (HALAR® — ethylene chlorotrifluoroethylene)

##### No Media-Contact Components:

- Body** CPVC (chlorinated polyvinylchloride)
- Stem** Type 316 Stainless Steel, PTFE coated
- O-ring Backing** FKM (fluorocarbon)
- Bushings** Glass Reinforced Polypropylene blend / Polyurethane
- Gear Operator** Die Cast Aluminum
- Handwheel** Polypropylene

#### Quick-View Valve Selection Chart

Valve Size	Part Number	Pressure Rating
2	253322-020	150 psi Non-Shock Water @ 73°F
3	253322-030	
4	253322-040	
6	253322-060	

**NOTE:** High Purity TFM Lined Butterfly Valve has the same basic dimensions as Spears® Standard Butterfly Valve.

HALAR® is a registered trademark of Ausimont, Inc.  
Hostafion® is a registered trademark of Hoechst Celanese Corporation.

## Pool Butterfly Valves



### PVC Pool Butterfly Valves



#### Features - PVC White

Distinct White Body with Blue Handle readily identifies this high quality PVC Butterfly Valve specifically designed for chlorinated water applications such as swimming pools. Fully isolated, non-wetted stainless steel stem with limited-contact EPDM seat provides maximum resistance to chlorinated water with superior ease of operation. Available in IPS sizes 1-1/2" through 12".

- White PVC Valve with Blue PP Handle provides easy application identification for chlorinated water
- Type 316L non-wetted stainless steel stem is fully isolated from system fluid, but still compatible with chlorinated water
- Patented limited-contact seat is field replaceable
- High-grade EPDM seat & seals
- Blue polypropylene lever handle with built-in lockout (10" & 12" valves are gear operated only)
- Optional gear operated valve with powder coated cast aluminum housing and Blue polypropylene handwheel
- ANSI/ASME B16.5 Class 150 bolt pattern flange connection
- All sizes pressure rated to 150 psi @ 73°F
- Optional SS 316 field-installable Lug Inserts sets
- Pneumatic or electric actuation available

#### Sample Engineering Specification

All Pool Butterfly Valves shall be constructed from PVC with EPDM seals suitable for chlorinated water applications. Valve body shall be white (gray disc) with blue handle for application identification. All handles shall be high impact polypropylene. Lever handles shall have built-in lockout capability. Stem shall be Type 316L stainless steel and non-wetted. Valve bodies shall have ANSI/ASME B16.5 bolt patterns and accept optional field installable lug inserts. Valves shall be pressure rated at 150 psi for water at 73°F, as manufactured by Spears® Manufacturing Company.

#### Quick-View Valve Selection Chart

PVC Lever Handle with EPDM Seat		
Size	Part Number	Pressure Rating
1-1/2	682311-015	150 psi Non-Shock Water @ 73°F
2	682311-020	
2-1/2	682311-025	
3	682311-030	
4	682311-040	
6	682311-060	
8	682311-080	
PVC Gear Operated with EPDM Seat		
Size	Part Number	Pressure Rating
1-1/2	682321-015	150 psi Non-Shock Water @ 73°F
2	682321-020	
2-1/2	682321-025	
3	682321-030	
4	682321-040	
6	682321-060	
8	682321-080	
10	682321-100	
12	682321-120	

**CAUTION: THE POOL BUTTERFLY VALVE IS NEITHER INTENDED NOR WARRANTED FOR INDUSTRIAL OR CHEMICAL PROCESSING APPLICATIONS**





## Thermoplastic Valves Product Guide & Engineering Specifications Butterfly Valve Dimensions & Operational Information

### Replacement Parts for 1-1/2" - 12" PVC & CPVC Standard, True Lug and Polypropylene Valves

No	Component	Qty.	Material
1	Body	1	PVC/CPVC
2	Stem Bearing	1	PTFE/GFPP
3	Seal Carrier	1	PVC/CPVC/PP
4	Seat	1	Buna-N, EPDM, FKM
5	Disc	1	PVC/CPVC/PP
6	Disc O-ring	2	Buna-N, EPDM, FKM
7	Stem Bushing	1	PTFE/GFPP
8	Stem Bushing O-ring	2	Buna-N, EPDM, FKM
9	Stem O-ring	2	Buna-N, EPDM, FKM
10	Stem Washer - Hex	1	PTFE
11	Stem Washer - Slot*	1-2	SS 316
12	Stem Washer - Round	1	PTFE/GFPP
13	Stem	1	SS 316
14	Stem Nut	1	PVC/CPVC
15	Handle Body	1	PP
16	Handle Grip	1	GFPVC
17	Grip Pin	1	PP
18	Lock Pin	1	PP
19	Handle Lock	1	GFPVC
20	Handle Spring	1	SS 316
21	Handle Cover	1	PP
22	Hex Bolt	1	SS 316
23	Flat Washer	1	SS 316
24	Handle Bushing	1	GFPVC
25	Disc Timing Stop	1	CPVC
26	Lug Insert	4-12	SS/Zinc Plated Steel
27	Gear Operator Assembly	1	Cast Aluminum
28	Hand Wheel	1	PP
<b>True Lug Only (not shown):</b>			
Seal Carrier Flange Plate	1	PVC/CPVC	
Lug & Nut	4-12	SS/Zinc Plated Steel	
Plate O-ring	1	Buna-N, EPDM, FKM	

**Notes:** \*2-Slotted washers used on 6" & larger  
1: See 14"-24" PP valve illustration for Gear Operator Components, No. 8 - 16

### 14" - 24" VALVES

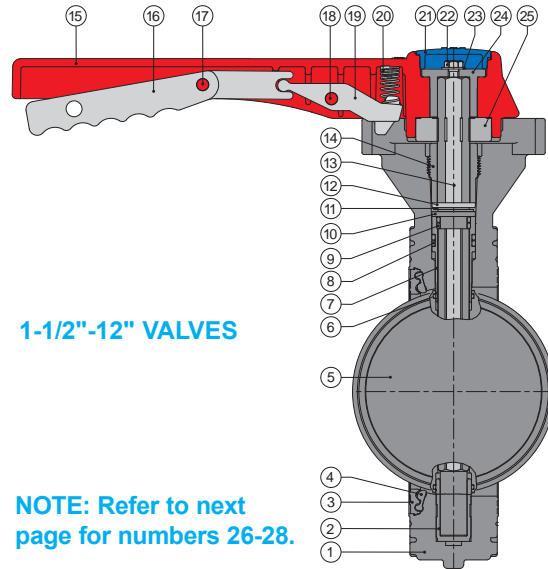
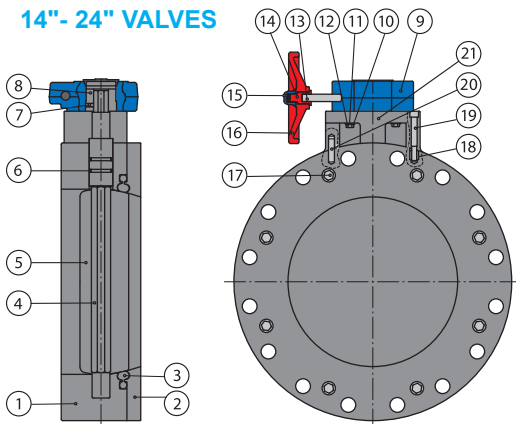

### 1-1/2"-12" VALVES

**NOTE:** Refer to next page for numbers 26-28.

### Replacement Parts for 14" - 24" Polypropylene Valves

No.	Component	Qty	Material
1	Body	1	PP
2	Seal Carrier	1	PP
3	Seat	1	EPDM/FKM
4	Stem	1	SS 316L
5	Disc	1	PP
6	Stem O-ring	2	EPDM/FKM
7	Set Screw	1	Steel
8	Drive Bushing	1	Steel
9	Gear Operator	1	Epoxy Coated Aluminum
10	Flat Washer	4	SS 316
11	Lock Washer	4	SS 316
12	Hex Head Cap Screw	4	SS 316
13	Handwheel Pin	1	SS 316
14	Handwheel Adapter	1	GFPVC
15	Handwheel Nut	1	PP
16	Handwheel	1	PP
17	Hex Bolts	6-12	Nylon
18	Thread Insert	2	Steel
19	Hex Head Cap Screws	2	SS 316
20	Dowel Pin	1	Steel
21	Tower	1	PP

# Thermoplastic Valves Product Guide & Engineering Specifications

## Butterfly Valve Dimensions & Operational Information



### Standard, True Lug & Polypropylene

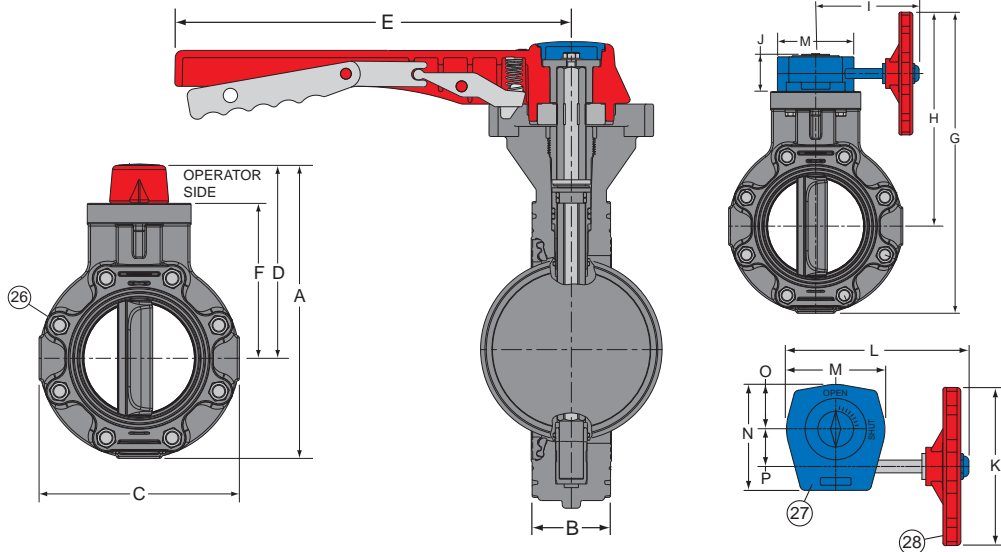

### Dimensions

Nominal Size	Pressure Rating <sup>1</sup> (psi)	A	B		C	D	E	F	G
			Standard, Lug Insert, & Polypropylene	True Lug					
1-1/2	150	8-5/32	1-9/16	2-1/4	5	5-19/32	9-3/32	4-3/32	11-5/32
2	150	9-11/32	1-15/16	2-9/16	6	6-13/32	9	4-3/4	13-1/8
2-1/2	150	10-9/32	2	2-3/4	7	6-25/32	9-1/4	5-1/4	13-1/8
3	150	11-1/2	2-3/32	2-13/16	7-1/2	7-27/32	12	5-5/8	14-5/32
4	150	13	2-9/32	3	9	8-1/2	12	6-1/4	15-5/8
6	150	16-19/32	2-3/4	3-13/32	10-31/32	11-3/32	13-7/8	8-19/32	19-7/32
8	150	18-5/8	2-15/16	3-23/32	13-1/2	12	13-15/16	9-1/2	21-7/16
10	150	N/A	3-1/4	4-1/4	16	N/A	N/A	11	26-5/8
12	150	N/A	3-1/2	4-1/2	19	N/A	N/A	12	29-1/8
14	100 <sup>2</sup>	N/A	6-1/4	N/A	21	N/A	N/A	13-3/16	29
16	85 <sup>2</sup>	N/A	6-3/4	N/A	23-1/2	N/A	N/A	14-7/16	31-1/2
18	70 <sup>2</sup>	N/A	7-1/8	N/A	25	N/A	N/A	15-3/16	33
20	50 <sup>2</sup>	N/A	7-3/4	N/A	27-1/2	N/A	N/A	16-7/16	35-1/2
24	50 <sup>2</sup>	N/A	8-7/16	N/A	32	N/A	N/A	18-11/16	40
30-60	<b>Contact Spears® for 30" to 60" Valve Dimensions</b>								

Nominal Size	H	I	J	K	L	M	N	O	P
1-1/2	8-21/32	6-7/16	2-3/8	8	8-13/16	4-13/16	5-3/16	2-13/16	1-27/32
2	10-1/8	6-7/16	2-3/8	8	8-13/16	4-13/16	5-3/16	2-13/16	1-27/32
2-1/2	9-5/8	6-7/16	2-3/8	8	8-13/16	4-13/16	5-3/16	2-13/16	1-27/32
3	10-17/32	6-7/16	2-3/8	8	8-13/16	4-13/16	5-3/16	2-13/16	1-27/32
4	11-1/8	6-7/16	2-3/8	8	8-13/16	4-13/16	5-3/16	2-13/16	1-27/32
6	13-23/32	6-7/16	2-13/32	7-15/16	8-7/8	4-27/32	5-5/32	2-7/32	1-27/32
8	14-11/16	6-7/16	2-13/32	7-15/16	8-7/8	4-27/32	5-3/16	2-7/32	1-27/32
10	18-5/8	7-1/8	2-3/8	8	9-13/16	5-3/8	5-15/16	2-7/16	2-11/32
12	19-5/8	7-1/8	2-3/8	8	9-13/16	5-3/8	5-15/16	2-7/16	2-11/32
14	18-1/2	7-3/8	2-9/16	8	10-13/16	6-7/8	7-7/16	3-1/8	3
16	19-3/4	7-3/8	2-9/16	8	10-13/16	6-7/8	7-7/16	3-1/8	3
18	20-1/2	7-3/8	2-9/16	8	10-13/16	6-7/8	7-7/16	3-1/8	3
20	21-3/4	7-3/8	2-9/16	8	10-13/16	6-7/8	7-7/16	3-1/8	3
24	24	7-3/8	2-9/16	8	10-13/16	6-7/8	7-7/16	3-1/8	3
30-60	<b>Contact Spears® for 30" to 60" Valve Dimensions</b>								

1: Maximum Internal Pressure Rating @ 73°F

2: Additional pressure rating is possible with attention to flow direction.



## Thermoplastic Valves Product Guide & Engineering Specifications Butterfly Valve Dimensions & Operational Information

### C<sub>v</sub> Values & Operating Torque

Valve Size	C <sub>v</sub> <sup>1</sup> Degrees Open						Operating <sup>2</sup> Torque (in.-lbs.)
	15°	30°	45°	60°	75°	90°	
1-1/2	2	8	20	36	61	81	100
2	3	11	27	49	82	109	110
2-1/2	5	19	48	86	144	192	206
3	9	35	86	155	259	345	360
4	10	41	103	185	308	411	420
6	28	113	281	506	844	1125	720
8	56	225	562	1012	1687	2249	1200
10	111	444	1110	1998	3330	4440	1320
12	158	631	1577	2839	4732	6309	1920
14	176	705	1762	3172	5286	7048	See Notes
16	211	846	2114	3805	6341	8455	
18	273	1092	2730	4914	8190	10920	
20	355	1418	3545	6381	10635	14180	
24	467	1866	4665	8397	13995	18660	

1: Gallons per minute at 1 psi pressure drop.

2: Operating torque for large diameter valves varies significantly with system operating pressure, flow direction and velocity. Contact Spears® for torque requirement based on application.

### Actuator Mounting Dimensions For Custom Actuation

Size	Bolt Hole Spacing		Bolt Hole Diameter		Bolt Circle Diameter		Hex	Square	Stem Height	
	Standard	Wafer	Standard	Wafer	Standard	Wafer	+0.000 -0.006	+0.000 -0.002	Standard	Wafer
1-1/2	1.95	N/A	.34	N/A	2.75	N/A	.375	N/A	.75	N/A
2	1.95	2.47	.34	.40	2.75	3.50	.500	.375	.75	1.30
2-1/2	1.95	2.47	.34	.40	2.75	3.50	.500	.375	.75	1.34
3	2.65	2.47	.41	.40	3.75	3.50	.563	.500	1.00	1.34
4	2.65	2.47	.41	.40	3.75	3.50	.625	.500	1.04	1.37
6	3.17	2.83	.41	.40	4.48	4.00	.875	.750	1.27	1.80
8	3.17	3.17	.41	.40	4.48	4.48	1.000	.875	1.29	1.96
10	3.54	N/A	.41	N/A	5.00	N/A	1.125	N/A	1.38	N/A
12	3.54	N/A	.41	N/A	5.00	N/A	1.250	N/A	1.38	N/A
14	3.54	N/A	.41	N/A	5.00	N/A	1.250	N/A	1.62	N/A
16	3.54	N/A	.41	N/A	5.00	N/A	1.250	N/A	1.75	N/A
18	3.54	N/A	.41	N/A	5.00	N/A	1.250	N/A	1.75	N/A
20	3.93	N/A	.41	N/A	5.56	N/A	1.250	N/A	1.75	N/A
24	4.33	N/A	.41	N/A	6.12	N/A	1.250	N/A	1.75	N/A

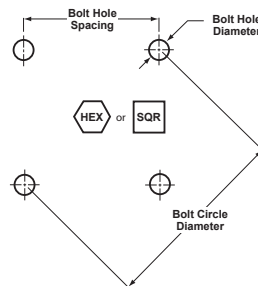
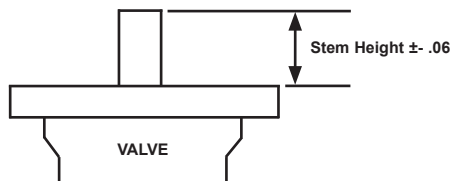

**Note:** Standard = Standard, Lug & True Lug Style Valves  
Wafer = Wafer Style Valves

# Thermoplastic Valves Product Guide & Engineering Specifications Butterfly Valve Dimensions & Operational Information



## General Installation Information

Spears® Butterfly Valves are designed for system connections either between two flanges, or with single-side (flange one-side only) connection for dead-end service using lug style valves. Lug Insert Valves require attention to flow direction, True Lug valves may be installed either direction. The valve handle (or gear operator) is reversible 180° for either left or right side operation. Spears® Butterfly Valves are designed for installation with user supplied 1/8" full-faced gaskets, hex bolts, nuts and flat washers.

**Caution:** Spears® Butterfly Valves are designed for use with flanges or flanged equipment having minimum waterway inside diameter no less than that of Schedule 80 PVC pipe (ASTM D 1785). *Use of smaller inside diameter flange connections may result in obstruction and damage to the valve disc.*

## PVC & CPVC Butterfly Valve Torque and Hardware Requirements

Valve Size (in.)	No. of Bolt Holes	Bolt Torque (ft.-lb.)	Standard Valve						Valve with Lug Inserts					True Lug Valve			
			Bolt Lengths <sup>1</sup> (in.)		Bolt Diameter (in.)	Bolt Threads per inch	Flat Washer O.D. (in.)	Bolt Lengths <sup>1</sup> (in.)		Bolt Diameter (in.)	Lug Threads per inch	Flat Washer O.D. (in.)	Bolt Lengths <sup>2</sup> (in.)	Bolt Diameter (in.)	Lug Threads per inch	Flat Washer O.D. (in.)	
			Single Side	Dual Flange <sup>3</sup>				Single Side	2nd Flange <sup>2</sup>								
1-1/2	4	12	3-1/4	4-1/4	1/2	13	1-3/8	1-3/4	1-1/2	1/2	13	1-3/8	1-1/2	7/16	14	1-1/4	
2	4	25	3-3/4	4-3/4	5/8	11	1-3/4	2	1-3/4	5/8	11	1-3/4	1-1/2	1/2	13	1-3/8	
2-1/2	4	25	4-1/4	5-1/4	5/8	11	1-3/4	2-1/4	2	5/8	11	1-3/4	1-3/4	1/2	13	1-3/8	
3	4	25	4-1/4	5-1/2	5/8	11	1-3/4	2-1/4	2	5/8	11	1-3/4	2	1/2	13	1-3/8	
4	8	25	4-1/2	5-3/4	5/8	11	1-3/4	2-1/2	2	5/8	11	1-3/4	2	1/2	13	1-3/8	
6	8	40	5-1/4	6-3/4	3/4	10	2	3-1/4	2-1/4	3/4	10	2	2-1/4	5/8	11	1-3/4	
8	8	40	5-3/4	7-1/4	3/4	10	2	3-3/4	2-1/4	3/4	10	2	2-1/4	5/8	11	1-3/4	
10	12	64	6-1/2	8-1/4	7/8	9	2-1/4	4	3	7/8	9	2-1/4	2-3/4	3/4	10	2	
12	12	95	6-3/4	8-1/2	7/8	9	2-1/4	4-1/4	3	7/8	9	2-1/4	2-3/4	3/4	10	2	

1: Minimum bolt lengths based on use of Spears® flanges, 1/8" full faced gaskets, standard S.A.E. hex bolts and Standard Plate Series flat washers.

2: Specified bolt lengths are **maximum allowable** for maintaining proper clearance in initial Single-Side installation with Lugs where anticipated 2nd Flange installation option is to be retained without removal of valve.

3: Minimum bolt length through 2-flanges, 2-gaskets, 2-flat washers and 1-valve body.

## Single-Side (flange one side) Installation Using Standard Valve with Lug Inserts (for field installable Insert Sets or valves with factory installed Lug Inserts)

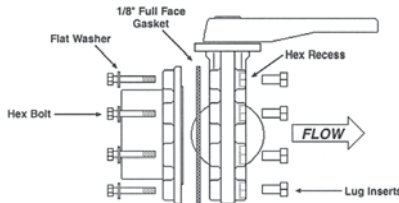

**CAUTION:** Flange must be installed on side of valve **opposite** the hex nut recesses for Single-Side Installation as illustrated.

(Flange, bolts, nuts, washers and gaskets not included. Lug inserts may be ordered separately.)



## Polypropylene Butterfly Valve Torque and Hardware Requirements

Valve Size	No. of Bolt Holes	Bolt Diameter (in.)	Bolt Torque (ft.-lb.)	Bolt Lengths	Valve Lay Length
1-1/2	4	1/2	12	Bolt lengths will vary according to thickness of valve, mating flanges, nuts and gaskets used.  The following formula may be use to calculate bolt length for installation with mating flange each side.  $L = V + 2 ( F + G + W ) + N$ Where: L = Minimum Bolt Length V = Valve Lay Length F = Flange Thickness G = Gasket Thickness W = Washer Thickness N = Nut Thickness	1-9/16
2	4	5/8	25		1-7/8
2-1/2	4	5/8	25		2-1/16
3	4	5/8	25		2-1/8
4	8	5/8	25		2-5/16
6	8	3/4	40		3
8	8	3/4	40		2-3/4
10	12	7/8	64		3-1/4
12	12	7/8	95		3-1/2
14	12	1	110		6-1/4
16	16	1	110		6-3/4
18	16	1-1/8	110		7-1/8
20	20	1-1/8	110		7-3/4
24	20	1-1/4	110		8-1/2



## Thermoplastic Valves Product Guide & Engineering Specifications

### Butterfly Valve Accessories

#### Lug Insert Sets



- Field installable lugs for all Spears® PVC & CPVC Standard Butterfly Valves only.
- Allows easy single-side installation to mating flange.
- Choice of high corrosion resistant 316 stainless steel or zinc plated steel construction.

Valve Size	316 Stainless Steel Part Number	Zinc Plated Steel Part Number
1-1/2	LUG1-015	LUG2-015
2 & 2-1/2	LUG1-020	LUG2-020
3	LUG1-030	LUG2-030
4	LUG1-040	LUG2-040
6 & 8	LUG1-080	LUG2-080
10 & 12	LUG1-120	LUG2-120

#### Lever Handle Kits



- Exact replacement or conversion handle for Spears® 1-1/2" through 8" Butterfly Valves.
- High impact polypropylene construction featuring quick-action reinforced polymer position stop and grip with built-in lock-out capability.
- Includes all components and hardware assembled for quick installation.

Valve Size	Part Number
1-1/2	BFH-015
2 & 2-1/2	BFH-020
3	BFH-030
4	BFH-040
6	BFH-060
8	BFH-080

#### T-Handle Kits



- Specialty Handle for minimum space requirements.
- High impact polypropylene construction featuring quick-action reinforced polymer position stop and grip with built-in lock-out capability.

Valve Size	Part Number
3	BFTH-030
4	BFTH-040

#### Speed Handle for Gear Operator



- Quickly attaches to Spears® Gear Operator Handle to allow rapid opening or closing of valve.

Valve Size	Part Number
1-1/2 - 12	SH-120

#### Positive Stem Stop for Butterfly Valve with Gear Operator



- Provides positive stop for Gear Operator shaft to avoid changes in the degree of opening for varying flow conditions.

Valve Size	Part Number
1-1/2 - 12	PSS-120
14 - 24	PSS-240

#### 2" Square / T-Style Operator Nuts



- Allows operation with conventional 2" Square or T-Style handle wrenches.
- Fits All Spears® Butterfly Valve Gear Operators.

(NOT FOR USE ON VALVE STEM)

Valve Size	Part Number
1-1/2 - 24	GTN-040



### Gear Operator Kits



For Wafer Style Butterfly Valves replace the “GO” prefix with “GOW” in the part number.

- Bolt-on conversion or replacement unit for all Spears® Butterfly Valves.
- Cast aluminum construction with high efficiency worm gear drive, built-in position indicator and easy-grip polypropylene handwheel.
- Includes all components and hardware for direct mount to valve.

### Gear Operator Kits

Valve Size	1-1/2	2	2-1/2	3	4	6	8	10	12
<b>Part Number</b>	GO-015	GO-020	GO-025	GO-030	GO-040	GO-060	GO-080	GO-100	GO-120

### Powder Coated Gear Operator Kits

Valve Size	1-1/2	2	2-1/2	3	4	6	8	10	12
<b>Part Number</b>	GOP-015	GOP-020	GOP-025	GOP-030	GOP-040	GOP-060	GOP-080	GOP-100	GOP-120

### Extended Chemical Resistance Options

Spears® offers several options for extended chemical resistance in PVC, CPVC and Polypropylene Butterfly Valves, including those listed below. Contact Spears® for additional ordering information.

#### PTFE Seat Sleeves

- PTFE envelope-type sleeve encases and isolates Spears® standard elastomer seat for extended chemical resistance while maintaining resiliency and sealing capability.
- Available for valve sizes 1-1/2" - 12"
- Sold factory-installed in PVC, CPVC or PP valves.

#### PTFE Coated Valve Stems

- Durable, bonded PTFE coating over standard SS 316L stem for extended chemical resistance.
- Viable alternative to more costly special alloy stems.
- Available for all valve sizes.
- Sold factory installed in PVC, CPVC or PP valves.



### True-Lug Butterfly Valve Bolt Kit

Connects 1-Side of True-Lug Valve to 1-Spears® Flange Includes Bolts & Flat Washers  
 Use 2-Kits For Dual Spears® Flanges

Size	Part Number		
	Zinc Plated	SS316	SS304
1-1/2	BFHKL-015	BFHKL1-015	BFHKL2-015
2	BFHKL-020	BFHKL1-020	BFHKL2-020
2-1/2	BFHKL-025	BFHKL1-025	BFHKL2-025
3	BFHKL-030	BFHKL1-030	BFHKL2-030
4	BFHKL-040	BFHKL1-040	BFHKL2-040
6 & 8	BFHKL-080	BFHKL1-080	BFHKL2-080
10 & 12	BFHKL-120	BFHKL1-120	BFHKL2-120



## Thermoplastic Valves Product Guide & Engineering Specifications

### Butterfly Valve Accessories



(VALVE NOT INCLUDED)

### Chainwheel Operator Kits

For Wafer Style Butterfly Valves replace the “CO” prefix with “COW” in the part number.

- Bolt-on conversion unit for all Spears® Butterfly Valves. Includes all hardware for direct mount to valve.
- Enables operation of Spears® Butterfly Valves in high, normally out of reach locations. Makes valve opening or closing easy by means of a slight pull on the sprocket chain.
- Unit consists of Cast Aluminum high efficiency Gear Operator with Aluminum Alloy Sprocket Rim and Chain Guide.
- Chain options provide choice of 316 Stainless Steel, Hot-Dipped Galvanized or Brass. Order separately to desired length.

**Note:** In horizontal system installations, Chainwheel Operators should be generally mounted with operator below valve (inverted valve) to maintain clearance between chain and system piping. Check for adequate clearance before installing an operator in a top-mount position.

Valve Size	Part Number
2	CO-020
2-1/2	CO-025
3	CO-030
4	CO-040
6	CO-060
8	CO-080
10	CO-100
12	CO-120
14-24	CO-140

2-1/2" and smaller kits available on special order basis.

LOCK-LINK CHAIN OPTIONS	Part Number
Hot-Dip Galvanized	GC-1
Brass	BC-1
Stainless Steel	SC-1

### Determining Floor-to-Chainwheel Height

Typical orientation is shown for valve in horizontal piping system installation. Floor-to-Chainwheel height is determined by subtracting the specified “C” dimension from the system centerline height (add “C” dimension if used with top-mount orientation). In vertical piping system installations, the Floor-to-Chainwheel height is the same as that for the centerline location of the valve in the system.

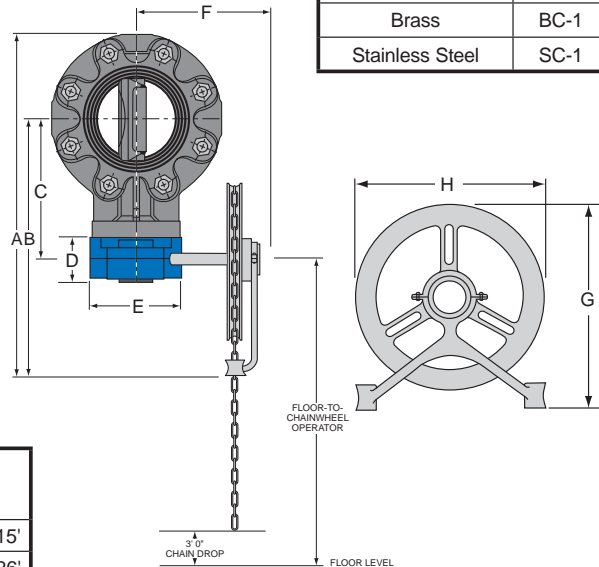

### How to Order Chain

Required chain length is based on chain drop at 3 ft. from floor.

Floor-to-Chainwheel Height	7'	8'	9'	10'	11'	12'	13'	14'	15'
Required Chain Length	10'	12'	14'	16'	18'	20'	22'	24'	26'

### Chainwheel Operator Dimensions (Note: w denotes Wafer Style Butterfly Valve Dimensions)

Valve Size	A	A w	B	B w	C	C w	D	D w	E	E w	F	F w	G	G w	H	H w
2	12-15/16	12-3/16	9-15/16	9-1/8	5-7/8	5-1/8	2-3/8	2-3/8	4-13/16	4-13/16	5-7/16	5-7/16	7-3/4	7-3/4	7-3/8	7-3/8
2-1/2	13-11/16	13-3/16	10-3/16	9-5/8	6-1/8	5-5/8	2-3/8	2-3/8	4-13/16	4-13/16	5-7/16	5-7/16	7-3/4	7-3/4	7-3/8	7-3/8
3	14-7/16	13-3/4	10-11/16	10-1/16	6-5/8	6-1/16	2-3/8	2-3/8	4-13/16	4-13/16	5-7/16	5-7/16	7-3/4	7-3/4	7-3/8	7-3/8
4	15-15/16	14-13/16	11-7/16	10-1/2	7-3/8	6-1/2	2-3/8	2-3/8	4-13/16	4-13/16	5-7/16	5-7/16	7-3/4	7-3/4	7-3/8	7-3/8
6	19-5/16	17-13/16	13-13/16	12-1/4	9-3/4	8-1/4	2-3/8	2-3/8	4-13/16	4-13/16	5-7/16	5-7/16	7-3/4	7-3/4	7-3/8	7-3/8
8	21-9/16	20-7/16	14-13/16	13-9/16	10-3/4	9-9/16	2-3/8	2-3/8	4-13/16	4-13/16	5-7/16	5-7/16	7-3/4	7-3/4	7-3/8	7-3/8
10	24-3/16	—	16-3/16	—	12-1/8	—	2-3/8	—	5-3/8	—	6-7/16	—	7-3/4	—	7-3/8	—
12	26-11/16	—	17-3/16	—	13-1/8	—	2-3/8	—	5-3/8	—	6-7/16	—	7-3/4	—	7-3/8	—
14	31	—	20-1/2	—	14-1/2	—	2-3/4	—	6-7/8	—	7-1/4	—	10-1/2	—	9	—
16	33-1/2	—	21-3/4	—	15-3/4	—	2-3/4	—	6-7/8	—	7-1/4	—	10-1/2	—	9	—
18	35	—	22-1/2	—	16-1/2	—	2-3/4	—	6-7/8	—	7-1/4	—	10-1/2	—	9	—
20	37-1/2	—	23-3/4	—	17-3/4	—	2-3/4	—	6-7/8	—	7-1/4	—	10-1/2	—	9	—
24	42	—	26	—	20	—	2-3/4	—	6-7/8	—	7-1/4	—	10-1/2	—	9	—

Thermoplastic Valves Product Guide & Engineering Specifications  
**Butterfly Valve Accessories**



**Stem Extensions**

For Wafer Style Butterfly Valves replace the “BFSE” prefix with “BFSEW” in the part number.

- Designed for use on Spears® Butterfly Valves.
- Corrosion Resistant PVC Housing.
- Stainless Steel Internal Extension Shaft.
- All Mounting Hardware Included.
- Detailed Instructions for Quick Assembly.
- Fabricated to Order in Standard 6" Increments.

*Typical Application (VALVE NOT INCLUDED)*

*Gear Operator (shown) or Lever Handle Sold with Valve*

Stem Extension Height	Valve Size						
	1-1/2	2 & 2-1/2	3	4	6	8	10
24	BFSE-015-240	BFSE-020-240	BFSE-030-240	BFSE-040-240	BFSE-060-240	BFSE-080-240	BFSE-100-240
30	BFSE-015-300	BFSE-020-300	BFSE-030-300	BFSE-040-300	BFSE-060-300	BFSE-080-300	BFSE-100-300
36	BFSE-015-360	BFSE-020-360	BFSE-030-360	BFSE-040-360	BFSE-060-360	BFSE-080-360	BFSE-100-360
42	BFSE-015-420	BFSE-020-420	BFSE-030-420	BFSE-040-420	BFSE-060-420	BFSE-080-420	BFSE-100-420
48	BFSE-015-480	BFSE-020-480	BFSE-030-480	BFSE-040-480	BFSE-060-480	BFSE-080-480	BFSE-100-480
54	BFSE-015-540	BFSE-020-540	BFSE-030-540	BFSE-040-540	BFSE-060-540	BFSE-080-540	BFSE-100-540
60	BFSE-015-600	BFSE-020-600	BFSE-030-600	BFSE-040-600	BFSE-060-600	BFSE-080-600	BFSE-100-600
66	BFSE-015-660	BFSE-020-660	BFSE-030-660	BFSE-040-660	BFSE-060-660	BFSE-080-660	BFSE-100-660
72	BFSE-015-720	BFSE-020-720	BFSE-030-720	BFSE-040-720	BFSE-060-720	BFSE-080-720	BFSE-100-720
78	BFSE-015-780	BFSE-020-780	BFSE-030-780	BFSE-040-780	BFSE-060-780	BFSE-080-780	BFSE-100-780
84	BFSE-015-840	BFSE-020-840	BFSE-030-840	BFSE-040-840	BFSE-060-840	BFSE-080-840	BFSE-100-840
90	BFSE-015-900	BFSE-020-900	BFSE-030-900	BFSE-040-900	BFSE-060-900	BFSE-080-900	BFSE-100-900
96	BFSE-015-960	BFSE-020-960	BFSE-030-960	BFSE-040-960	BFSE-060-960	BFSE-080-960	BFSE-100-960
102	BFSE-015-1020	BFSE-020-1020	BFSE-030-1020	BFSE-040-1020	BFSE-060-1020	BFSE-080-1020	BFSE-100-1020
108	BFSE-015-1060	BFSE-020-1080	BFSE-030-1080	BFSE-040-1080	BFSE-060-1080	BFSE-080-1080	BFSE-100-1080
114	BFSE-015-1140	BFSE-020-1140	BFSE-030-1140	BFSE-040-1140	BFSE-060-1140	BFSE-080-1140	BFSE-100-1140
120	BFSE-015-1200	BFSE-020-1200	BFSE-030-1200	BFSE-040-1200	BFSE-060-1200	BFSE-080-1200	BFSE-100-1200

Stem Extension Height	Valve Size					
	12	14	16	18	20	24
24	BFSE-120-240	BFSE-140-240	BFSE-160-240	BFSE-180-240	BFSE-200-240	BFSE-240-240
30	BFSE-120-300	BFSE-140-300	BFSE-160-300	BFSE-180-300	BFSE-200-300	BFSE-240-300
36	BFSE-120-360	BFSE-140-360	BFSE-160-360	BFSE-180-360	BFSE-200-360	BFSE-240-360
42	BFSE-120-420	BFSE-140-420	BFSE-160-420	BFSE-180-420	BFSE-200-420	BFSE-240-420
48	BFSE-120-480	BFSE-140-480	BFSE-160-480	BFSE-180-480	BFSE-200-480	BFSE-240-480
54	BFSE-120-540	BFSE-140-540	BFSE-160-540	BFSE-180-540	BFSE-200-540	BFSE-240-540
60	BFSE-120-600	BFSE-140-600	BFSE-160-600	BFSE-180-600	BFSE-200-600	BFSE-240-600
66	BFSE-120-660	BFSE-140-660	BFSE-160-660	BFSE-180-660	BFSE-200-660	BFSE-240-660
72	BFSE-120-720	BFSE-140-720	BFSE-160-720	BFSE-180-720	BFSE-200-720	BFSE-240-720
78	BFSE-120-780	BFSE-140-780	BFSE-160-780	BFSE-180-780	BFSE-200-780	BFSE-240-780
84	BFSE-120-840	BFSE-140-840	BFSE-160-840	BFSE-180-840	BFSE-200-840	BFSE-240-840
90	BFSE-120-900	BFSE-140-900	BFSE-160-900	BFSE-180-900	BFSE-200-900	BFSE-240-900
96	BFSE-120-960	BFSE-140-960	BFSE-160-960	BFSE-180-960	BFSE-200-960	BFSE-240-960
102	BFSE-120-1020	BFSE-140-1020	BFSE-160-1020	BFSE-180-1020	BFSE-200-1020	BFSE-240-1020
108	BFSE-120-1080	BFSE-140-1080	BFSE-160-1080	BFSE-180-1080	BFSE-200-1080	BFSE-240-1080
114	BFSE-120-1140	BFSE-140-1140	BFSE-160-1140	BFSE-180-1140	BFSE-200-1140	BFSE-240-1140
120	BFSE-120-1200	BFSE-140-1200	BFSE-160-1200	BFSE-180-1200	BFSE-200-1200	BFSE-240-1200

Basic Stem Extension height is 24" and is manufactured in standard 6" increments. Intermediate Stem Extension heights are available and are priced to the next full 6" increment. For heights over 120", please contact your servicing Spears® Regional Distribution Center.



Thermoplastic Valves Product Guide & Engineering Specifications  
**True Union Ball Check Valves - See preceding sections on True Union 2000 and Regular True Union Ball Check Valves**



**True Union Ball Check Valves -**

See preceding sections on True Union 2000 and Regular True Union Ball Check Valves





### Sample Engineering Specification

All thermoplastic check valves shall be flanged Swing Check type constructed from PVC Type I, ASTM D 1784 Cell Classification 12454 or CPVC Type IV, ASTM D 1784 Cell Classification 23447, or Polypropylene, ASTM D 4101. All O-rings shall be EPDM or FKM. All valves components shall be replaceable. All valves shall have top-entry access with O-ring sealed drain plug for in-line servicing. All valves shall have optional external Arrow Position Indicator or optional external Counter Balance. All 3/4" - 4" valves shall be pressure rated to 150 psi, all 6" valves to 100 psi, and all 8" valves to 70 psi for water at 73°F, as manufactured by Spears® Manufacturing Company.

### Quick-View Valve Selection Chart

Valve Size	O-ring Material	Part Number <sup>1,2,3</sup>	Pressure Rating
3/4	EPDM	4423-007	150 psi Non-Shock Water @ 73°F
	FKM	4433-007	
1	EPDM	4423-010	
	FKM	4433-010	
1-1/4	EPDM	4423-012	
	FKM	4433-012	
1-1/2	EPDM	4423-015	
	FKM	4433-015	
2	EPDM	4423-020	
	FKM	4433-020	
2-1/2	EPDM	4423-025	
	FKM	4433-025	
3	EPDM	4423-030	
	FKM	4433-030	
4	EPDM	4423-040	
	FKM	4433-040	
6	EPDM	4423-060	100 psi @ 73°F
	FKM	4433-060	
8	EPDM	4423-080	70 psi @ 73°F
	FKM	4433-080	

1: For CPVC valves, add the letter "C" to part numbers listed (e.g. 4423-025C).  
 2: For valve with Arrow Position Indicator, add the letter "I" before the dash separator (e.g., 4423I-025).  
 3: For Polypropylene valves, add the letter "P" to the part number (e.g. 4423-025P).

### Features – PVC, CPVC & PP

Designed for optimum flow, quick response and positive shutoff with minimum turbulence, this industrial grade Swing Check Valve is used in a variety of industrial and chemical processing applications where high volume fluid transfer is required. Suitable for horizontal or up-flow vertical applications. Available in PVC, CPVC and Glass Filled Polypropylene, IPS 3/4" - 8" with Flanged Body.

Engineered for Quick Response, Full-Flow Fluid Transfer

- Heavy Bodied All-Plastic Interior Construction
- Top Access & O-ring Sealed Drain Plug for In-line Servicing
- Standard O-ring type Seat & Seals in EPDM or FKM
- Sizes 3/4" - 4" Pressure Rated to 150 psi @ 73°F, 6" Pressure Rated to 100 psi and 8" to 70 psi @ 73°F
- Stainless Steel External Hardware
- Fully Serviceable, Replaceable Components
- Suitable for Vacuum Service
- Assembled with Silicone-Free, Water Soluble Lubricants

### Options & Accessories

- External Arrow Position Indicator<sup>1</sup>
- External Counter Balance<sup>1</sup>
- Natural Polypropylene Body

<sup>1</sup>: Available as assembled valve or kit for installed valve

**General Installation Information:** Industrial Swing check valves are designed for horizontal installations, but may be installed in up-flow only vertical position. Check valves should be installed a minimum of ten (10) pipe diameters from pump or other sources of turbulence. Check valves **MUST** be installed with the valves **FLOW** arrow pointing in the direction of flow. Do not install valve upside down. Normal flange-bolt assembly in top holes of the valve flange requires bolt insertion through the companion flange with nuts secured on Swing Check flange side. Certain system configurations involving direct connection of a Swing Check Valve to other flanged equipment may require consideration of this bolt clearance.





## Thermoplastic Valves Product Guide & Engineering Specifications

# Industrial Swing Check Valves

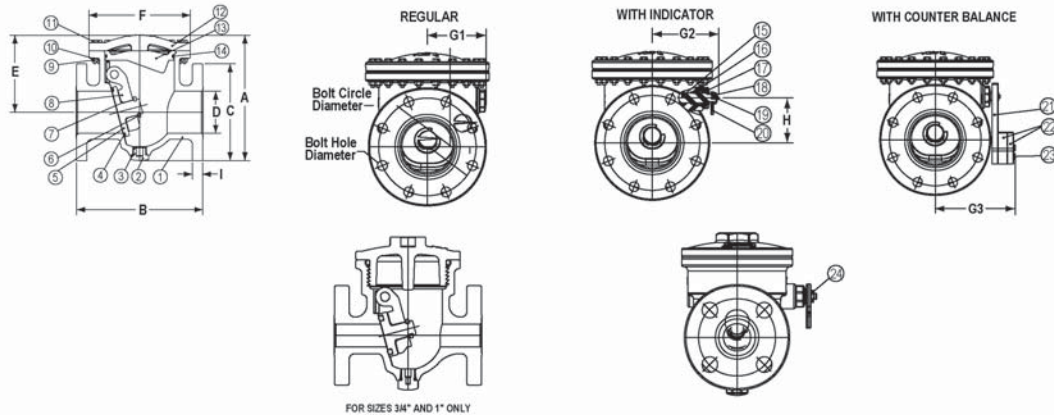

### Replacement Parts

No.	Component	Qty.	Material
1	Body	1	PVC/CPVC/PP
2	Plug	1	PVC/CPVC/PP
3	Plug O-ring	1	EPDM/FKM
4	Disc O-ring A	1	EPDM/FKM
5	Disc	1	PVC/CPVC/PP
6	Disc Ret. Clip	1	PP
7	Disc O-ring B	1	EPDM/FKM
8	Swing Arm	1	PVC/CPVC/PP
9	Nut	12-30	SS 316
10	Washer	24-60	SS 316
11	Bolt	12-30	SS 316
12	Bonnet	1	PVC/CPVC/PP

No.	Component	Qty.	Material
13	Seal Carrier	1	PVC/CPVC/PP
14	Body O-ring	1	EPDM/FKM
15	Arm Pin	1	PVC/CPVC/PP
16	Arm Pin Seal	2	FKM
17	Arm Pin Plug	1	PVC/CPVC/PP
18	Arm Pin Washer	1	SS 316
19	Arm Pin Bolt	1	SS 316
20	Indicator	1	PP
21	Counterbalance	1	PVC
22	Weight Block	1	PVC
23	Weight Block Bolt	2	SS 316
24	Arm Pin Ret. Clip	1	PP

### Dimensions & Weights

Nominal Size	A	B	C	D	E	F	G1	G2	G3	H	I	Approx. Wt (Lbs.)	
												PVC	CPVC
3/4	5-5/16	5-1/2	3-7/8	3/4	3-3/4	3-3/4	2-1/2	3	4	1-7/16	1/2	1.72	1.80
1	6-5/8	6-5/16	4-1/4	31/32	4-1/2	4-1/2	2-25/32	3-7/32	4-7/32	1-21/32	5/8	2.62	2.80
1-1/4	7-3/8	7-3/32	5	1-19/32	4-9/16	5-3/4	3-3/16	3-25/32	4-3/8	1-27/32	23/32	4.61	4.87
1-1/2	7-3/8	7-3/32	5	1-19/32	4-9/16	5-3/4	3-3/16	3-25/32	4-3/8	1-27/32	23/32	4.61	4.87
2	8-1/2	7-7/8	6	2	5-1/4	7	3-9/16	4-1/8	4-23/32	2-29/32	13/16	6.99	7.24
2-1/2	10-3/4	10-1/4	7-1/2	3-1/8	6-3/4	8-5/8	4-1/4	5	6-9/32	3-1/16	7/8	14.77	15.74
3	10-3/4	10-1/4	7-1/2	3-1/8	6-3/4	8-5/8	4-1/4	5	6-9/32	3-1/16	7/8	14.77	15.74
4	11-3/4	11-13/16	9	3-29/32	7-1/4	9-1/2	4-1/2	5-1/4	6-17/32	3-17/32	31/32	18.37	19.78
6	15-5/8	15-3/4	11	5-7/8	9-1/2	13-7/16	6	6-3/4	8-1/32	5-1/32	1	42.64	44.56
8	19-1/8	19-23/32	13-1/2	7-7/8	11-5/8	16-5/16	7	7-3/4	9-1/32	6-1/2	1-5/32	68.85	76.05

### C<sub>v</sub> Values

Valve Size	C <sub>v</sub> <sup>1</sup>
3/4	18
1	24
1-1/4	70
1-1/2	70
2	95
2-1/2	300
3	300
4	480
6	1100
8	1900

1: Gallons per minute at 1 psi pressure drop.

Nominal Size	Bolt Circle Diameter	Bolt Hole Diameter	Number of Bolt Holes
3/4	2-3/4	5/8	4
1	3-1/8	5/8	4
1-1/4	3-1/2	5/8	4
1-1/2	3-7/8	5/8	4
2	4-3/4	3/4	4
2-1/2	5-1/2	3/4	4
3	6	3/4	4
4	7-1/2	3/4	8
6	9-1/2	7/8	8
8	11-3/4	7/8	8



## Temperature Pressure Rating

System Operating Temperature °F (°C)			100 (38)	110 (43)	120 (49)	130 (54)	140 (60)	150 (66)	160 (71)	170 (77)	180 (82)	190 (88)	200 (93)	210 (99)
Valve Pressure Rating psi (MPa)	3/4" – 4"	PVC	150 (1.03)	135 (.93)	110 (.76)	75 (.52)	50 (.34)	-0-	-0-	-0-	-0-	-0-	-0-	-0-
		CPVC	150 (1.03)	140 (.97)	130 (.90)	120 (.83)	110 (.76)	100 (.70)	90 (.62)	80 (.55)	70 (.48)	60 (.41)	50 (.34)	-0-
		PP	150 (1.03)	105 (.72)	90 (.62)	80 (.55)	75 (.52)	65 (.45)	55 (.38)	50 (.34)	45 (.31)	-0-	-0-	-0-
	6"	PVC	100 (.70)	90 (.62)	80 (.55)	65 (.38)	50 (.34)	-0-	-0-	-0-	-0-	-0-	-0-	-0-
		CPVC	100 (.70)	95 (.66)	90 (.62)	85 (.59)	80 (.55)	75 (.48)	70 (.48)	65 (.45)	60 (.41)	55 (.38)	50 (.34)	-0-
		PP	100 (.70)	90 (.62)	85 (.59)	75 (.52)	70 (.48)	60 (.41)	55 (.38)	50 (.34)	45 (.31)	-0-	-0-	-0-
	8"	PVC	70 (.48)	65 (.45)	60 (.41)	50 (.34)	45 (.31)	-0-	-0-	-0-	-0-	-0-	-0-	-0-
		CPVC	70 (.48)	65 (.45)	62 (.43)	60 (.41)	57 (.39)	55 (.38)	52 (.36)	50 (.34)	45 (.31)	42 (.29)	40 (.28)	-0-
		PP	70 (.48)	60 (.41)	57 (.39)	55 (.38)	52 (.36)	50 (.34)	47 (.32)	45 (.31)	40 (.28)	-0-	-0-	-0-

## Arrow Position Indicator Kit

Spears® Swing Check Valve Indicator Kit is designed for field installation of external Indicator Arrow in Spears® Swing Check Valves. This kit can be installed through the bonnet assembly and removal of valve from line is not required.

### Kit Includes:

- 1 - Extended Shaft
- 2 - Shaft Cup Seals
- 1 - Shaft Nut
- 1 - Indicator Arrow
- 1 - Retaining clip

Valve Size	Part Numbers		
	PVC Kit	CPVC Kit	PP Kit
3/4	I3K-007	I3K-007C	I3K-007P
1	I3K-010	I3K-010C	I3K-010P
1-1/4 & 1-1/2	I3K-015	I3K-015C	I3K-015P
2	I3K-020	I3K-020C	I3K-020P
2-1/2 & 3	I3K-030	I3K-030C	I3K-030P
4	I3K-040	I3K-040C	I3K-040P
6	I3K-060	I3K-060C	I3K-060P
8	I3K-080	I3K-080C	I3K-080P

## Application of Counter Balance

Swing Check Valves operate in response to a fluid stream flow opening a swinging disc. As the fluid stream slows and reverses, the disc responds by swinging to the closed position. Sudden reversal of flow direction can result in “slamming” condition as the disc closes. The function of the Counter Balance mechanism is to start the disc closing earlier as the fluid stream begins to slow so that it is almost closed when flow reversal takes place, thereby eliminating slamming of the disc. Available as installed unit with valve or as a kit for adaptation of installed valves.



## Counter Balance Kits

Spears® Swing Check Valve Counter Balance Kit is designed for field installation of counter balance mechanism in Spears® Swing Check Valves. This kit can be installed through the bonnet assembly and removal of valve from line is not required.

### Kit Includes:

- 1 - Extended Shaft
- 2 - Shaft Cup Seals
- 1 - Shaft Nut
- 1 - Counter Balance
- 1 - Retaining Bolt
- 1 - Flat Washer
- 1 - Extra Weight Plates (1-small & 1-large)
- 1 - Plate Mounting Bolts (2-long & 2 short).

Valve Size	Part Numbers		
	PVC Kit	CPVC Kit	PP Kit
3/4	CB3K-007	CB3K-007C	CB3K-007P
1	CB3K-010	CB3K-010C	CB3K-010P
1-1/4 & 1-1/2	CB3K-015	CB3K-015C	CB3K-015P
2	CB3K-020	CB3K-020C	CB3K-020P
2-1/2 & 3	CB3K-030	CB3K-030C	CB3K-030P
4	CB3K-040	CB3K-040C	CB3K-040P
6	CB3K-060	CB3K-060C	CB3K-060P
8	CB3K-080	CB3K-080C	CB3K-080P



## Thermoplastic Valves Product Guide & Engineering Specifications

### Utility Swing & Spring Check Valves



### Sample Engineering Specification

All thermoplastic check valves shall be Utility Swing Check or Utility Spring Check type constructed from PVC Type I, ASTM D 1784 Cell Classification 12454. All valves shall be maintenance free seal unit construction with EPDM seat and weighted disc. All Spring Check Valves shall have stainless steel spring assisted operation. All valves shall have external flow direction designation. All valves shall be certified by NSF International for use in potable water service. All valves 1/2" – 4" shall be pressure rated to 150 psi for water @ 73°F in full flow (open) position and to 75 psi @ 73°F back pressure (closed), all valves 6" – 8" shall be pressure rated to 100 psi for water @ 73°F in full flow (open) position and to 50 psi @ 73°F back pressure (closed), as manufactured by Spears® Manufacturing Company.

### Quick-View Utility Swing Check Valve Selection Chart

Valve Size	Seat Material	PVC Material <sup>1</sup>			Pressure Rating
		Socket	Threaded	SR Threaded	
1/2	EPDM	S1520-05	S1520-05F	S1520-05FSR	150 psi @ 73°F Full Flow (Open) 75 psi Back Pressure (Closed)
3/4	EPDM	S1520-07	S1520-07F	S1520-07FSR	
1	EPDM	S1520-10	S1520-10F	S1520-10FSR	
1-1/4	EPDM	S1520-12	S1520-12F	S1520-12FSR	
1-1/2	EPDM	S1520-15	S1520-15F	S1520-15FSR	
2	EPDM	S1520-20	S1520-20F	S1520-20FSR	
2-1/2	EPDM	S1520-25	S1520-25F	S1520-25FSR	
3	EPDM	S1520-30	S1520-30F	S1520-30FSR	
4	EPDM	S1520-40	S1520-40F	S1520-40FSR	
6	EPDM	S1520-60	S1520-60F	S1520-60FSR	
8	EPDM	S1520-80	N/A	N/A	

<sup>1</sup>: For PVC Clear Swing Check, replace dash (-) separator with the letter "C" in the part number (e.g. S1520C05), (e.g. S1520C05F) or (e.g. S1520C05FSR)

### Features - PVC White & PVC Clear

Spears® Utility Swing Check and spring assisted Utility Spring Check Valves offer a compact, high performance check valve for Landscape & Irrigation, Pool & Spa, Aquaculture, OEM and many general purpose applications. These maintenance free sealed units feature long-life EPDM elastomer seats with weighted disc for full-flow with minimal restriction and positive shutoff. Spring assisted "Spring Check" model incorporates a positive-pressure spring to assist in valve closing without slamming. Produced from PVC White or PVC Clear material with Socket, Threaded or SR Threaded end connectors. Available in IPS Sizes 1/2" through 8" for Swing Check Valves and 1/2" through 4" for Spring Check Valves.

- Chemical & Corrosion Resistant PVC White or High Visibility PVC Clear Construction
- No Metal Parts on Swing Check - Stainless Steel Spring on Spring Check
- Maintenance Free Sealed Unit in a Compact Space Saving Design
- Engineered for Maximum Flow, Quick Response & Positive Shutoff
- Long-Life, High Grade EPDM Seat with Weighted Disc
- Spring Assisted Spring Check Model Option for Positive Closing
- Sizes 1/2" – 4" Pressure Rated to 150 psi @ 73°F Full Flow (open) and 75 psi @ 73°F Back Pressure (closed)
- Sizes 6" – 8" Pressure Rated to 100 psi @ 73°F Full Flow (open) and 50 psi @ 73°F Back Pressure (closed)
- Suitable for either Horizontal or Vertical Up-flow Installations and Vacuum Service
- NSF® Certified for Potable Water Use
- Silicone-Free Assembly

### Quick-View Utility Spring Check Valve Selection Chart

Valve Size	Seat Material	PVC Material <sup>1</sup>			Pressure Rating
		Socket	Threaded	SR Threaded	
1/2	EPDM	S1580-05	S1580-05F	S1580-05FSR	150 psi @ 73°F Full-Flow (Open)
3/4	EPDM	S1580-07	S1580-07F	S1580-07FSR	
1	EPDM	S1580-10	S1580-10F	S1580-10FSR	
1-1/4	EPDM	S1580-12	S1580-12F	S1580-12FSR	
1-1/2	EPDM	S1580-15	S1580-15F	S1580-15FSR	
2	EPDM	S1580-20	S1580-20F	S1580-20FSR	
2-1/2	EPDM	S1580-25	S1580-25F	S1580-25FSR	
3	EPDM	S1580-30	S1580-30F	S1580-30FSR	
4	EPDM	S1580-40	S1580-40F	S1580-40FSR	

<sup>1</sup>: For PVC Clear Spring Check, replace dash (-) separator with the letter "C" in the part number (e.g. S1580C05), (e.g. S1580C05F) or (e.g. S1580C05FSR)

# Thermoplastic Valves Product Guide & Engineering Specifications

## Utility Swing & Spring Check Valves



### Utility Swing Check Valve

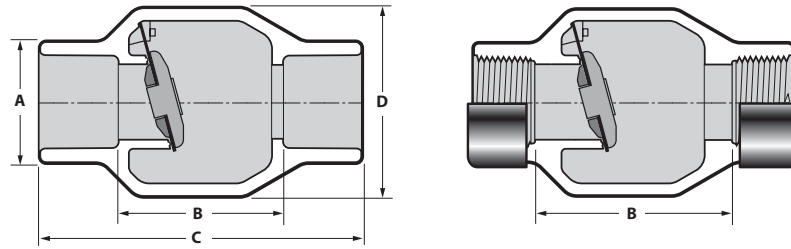

### Utility Spring Check Valve

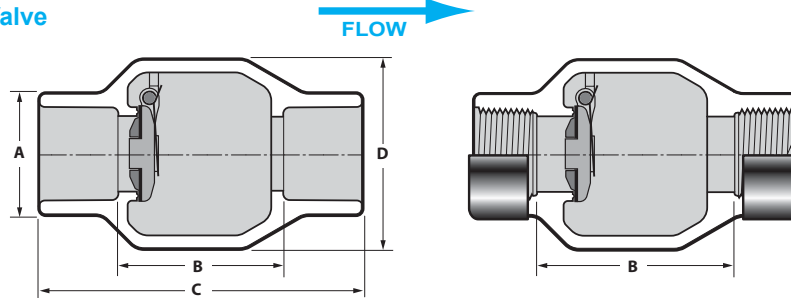

## Dimensions

Nominal Size	Dimension Reference (inches, ± 1/16)					
	A	B		C	D	
		Socket	Threaded/SR Threaded		Swing	Spring
1/2	1-3/8	2-19/32	2-5/8	4-3/32	2-1/8	2-5/8
3/4	1-3/8	2-5/32	2-1/16	4-1/16	2-1/8	2-5/8
1	1-11/16	2-5/16	2-15/16	4-9/16	2-5/8	2-5/8
1-1/4	2-1/16	2-15/16	3-5/8	5-1/2	3-3/8	3-3/8
1-1/2	2-7/16	3	3-11/16	5-5/8	3-3/8	3-3/8
2	3	3-5/8	4-3/8	6-3/8	4-1/4	4-1/4
2-1/2	3-9/16	4-3/8	5-1/4	7-7/8	5-1/8	5-1/8
3	4-5/16	4-11/16	5-5/8	8-7/16	5-3/4	5-3/4
4	5-1/4	6	7-1/16	10-1/16	6-3/8	6-3/8
6	7-11/16	8-1/2	11-5/16	14-9/16	9-1/4	N/A
8	9-7/16	11-3/16	N/A	19-1/4	11-15/16	N/A

**General Installation Information:** Utility Swing check valves are designed for horizontal installations, but may be installed in up-flow only vertical position. Check valves **MUST** be installed with the valves **FLOW** arrow pointing in the direction of the flow. Do not install valve upside down. Flow velocity should not exceed 5ft./sec. Minimum opening pressure less than 0.5 psi.

## Temperature Pressure Rating

System Operating Temperature °F (°C)			100 (38)	110 (43)	120 (49)	130 (54)	140 (60)	150 (66)	160 (71)	170 (77)	180 (82)	190 (88)	200 (93)	210 (99)
Valve Pressure Rating psi (MPa)	1/2" - 8"	PVC	150 (1.03)	135 (.93)	110 (.76)	75 (.52)	50 (.34)	-0- (-0-)	-0- (-0-)	-0- (-0-)	-0- (-0-)	-0- (-0-)	-0- (-0-)	-0- (-0-)
			150 (1.03)	140 (.97)	130 (.90)	120 (.83)	-110- (.76)	-100- (.70)	-90- (.62)	-80- (.55)	-70- (.48)	-60- (.41)	-50- (.34)	-0- (-0-)





## Check Valves



### Features - PVC White & PVC Clear

Spears® True Union Utility Swing Check and spring assisted True Union Utility Spring Check Valves offer a compact, high performance check valve for Landscape & Irrigation, Pool & Spa, Aquaculture, OEM 1 and many general purpose applications. True Union design allows for easy in-line replacement of maintenance free sealed units. These valves feature long-life EPDM elastomer seats with weighted disc for full-flow with minimal restriction and positive shutoff. Spring assisted “Spring Check” model incorporates a positive-pressure spring to assist in valve closing without slamming. Produced from PVC White or PVC Clear material with Socket, Threaded or SR Threaded end connectors in IPS Sizes 1/2" through 4".

### Sample Engineering Specification

All thermoplastic check valves Shall be True Union Utility Swing Check or True Union Utility Spring Check type constructed from PVC Type I, ASTM D 1784 Cell Classification 12454. All union nuts shall have Buttress threads coupled to a replaceable sealed unit with EPDM seat and weighted disc. All Spring Check Valves shall have stainless steel spring assisted operation. All valves shall have external flow arrow direction designation. All valves shall be certified by NSF International for use in potable water service. All valves shall be pressure rated to 150 psi for water @73°F in full flow (open) position and to 75 psi @ 73°F back pressure (closed), as manufactured by Spears® Manufacturing Company.

- Chemical & Corrosion Resistant PVC White or High Visibility PVC Clear Construction
- No Metal Parts on Swing Check - Stainless Steel Spring on Spring Check
- True Union style for Easy In-line Replacement of Sealed Unit
- Strong Buttress Threaded Union Nuts
- Engineered for Maximum Flow, Quick Response & Positive Shutoff
- Long-Life, High Grade EPDM Seat with Weighted Disc
- Spring Assisted Spring Check Model Option for Positive Closing
- Pressure Rated to 150 psi @ 73°F Full-Flow (open) and 75 psi @ 73°F Back Pressure (closed)
- Suitable for either Horizontal or Vertical Up-flow Installations and Vacuum Service
- NSF® Certified for Potable Water Use
- Silicone-Free Assembly

### Quick-View True Union Utility Swing Check Valve Selection Chart

Valve Size	Seat Material	PVC Material <sup>1</sup>			Pressure Rating
		Socket	Threaded	SR Threaded	
1/2	EPDM	S1720-05	S1720-05F	S1720-05FSR	150 psi @ 73°F Full Flow (Open)
3/4	EPDM	S1720-07	S1720-07F	S1720-07FSR	
1	EPDM	S1720-10	S1720-10F	S1720-10FSR	
1-1/4	EPDM	S1720-12	S1720-12F	S1720-12FSR	
1-1/2	EPDM	S1720-15	S1720-15F	S1720-15FSR	75 psi Back Pressure (Closed)
2	EPDM	S1720-20	S1720-20F	S1720-20FSR	
2-1/2	EPDM	S1720-25	S1720-25F	S1720-25FSR	
3	EPDM	S1720-30	S1720-30F	S1720-30FSR	
4	EPDM	S1720-40	S1720-40F	S1720-40FSR	

1: For PVC Clear Swing Check, replace dash (-) separator with the letter "C" in the part number (e.g. S1720C05), (e.g. S1720C05F) or (e.g. S1720C05FSR)

### Quick-View True Union Utility Spring Check Valve Selection Chart

Valve Size	Seat Material	PVC Material <sup>1</sup>			Pressure Rating
		Socket	Threaded	SR Threaded	
1/2	EPDM	S1780-05	S1780-05F	S1780-05FSR	150 psi @ 73°F Full Flow (Open)
3/4	EPDM	S1780-07	S1780-07F	S1780-07FSR	
1	EPDM	S1780-10	S1780-10F	S1780-10FSR	
1-1/4	EPDM	S1780-12	S1780-12F	S1780-12FSR	
1-1/2	EPDM	S1780-15	S1780-15F	S1780-15FSR	75 psi Back Pressure (Closed)
2	EPDM	S1780-20	S1780-20F	S1780-20FSR	
2-1/2	EPDM	S1780-25	S1780-25F	S1780-25FSR	
3	EPDM	S1780-30	S1780-30F	S1780-30FSR	
4	EPDM	S1780-40	S1780-40F	S1780-40FSR	

1: For PVC Clear Spring Check, replace dash (-) separator with the letter "C" in the part number (e.g. S1780C05), (e.g. S1780C05F) or (e.g. S1780C05FSR)

## Check Valves



### True Union Utility Swing Check Valve

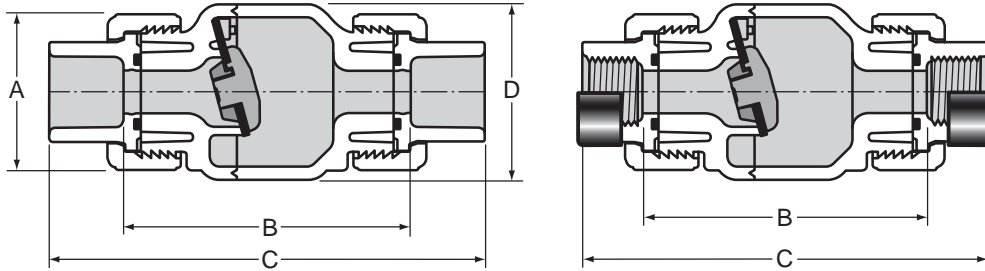

### True Union Utility Spring Check Valve

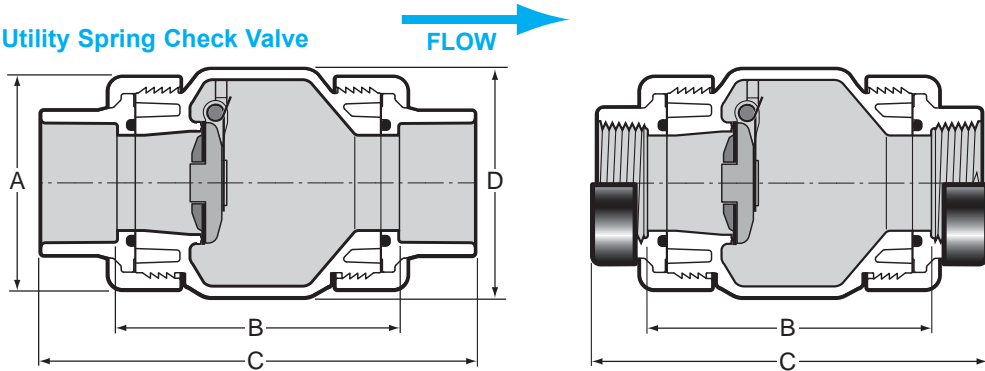

## Dimensions

Nominal Size	A	Dimension Reference (inches, ± 1/16)				D	
		B		C		Swing	Spring
		Socket	Threaded/SR Threaded	Socket	Threaded/SR Threaded		
1/2	1-7/8	3-7/16	3-1/2	5-3/16	4-13/16	2-1/8	2-5/8
3/4	2-1/4	3-9/16	3-9/16	5-1/2	4-15/16	2-1/8	2-5/8
1	2-9/16	4-1/8	4-5/16	6-7/16	6	2-5/8	2-5/8
1-1/4	3-1/8	4-7/8	5-1/16	7-7/16	6-13/16	3-3/8	3-3/8
1-1/2	3-9/16	4-9/16	4-3/4	7-3/8	6-1/2	3-3/8	3-3/8
2	4-5/16	5-5/8	5-3/4	8-5/8	7-9/16	4-1/4	4-1/4
2-1/2	6-3/16	7-7/16	7-9/16	10-15/16	10-3/16	5-11/16	5-11/16
3	6-13/16	7-7/16	7-1/2	11-3/16	10-1/4	5-11/16	5-11/16
4	7-3/4	9-3/4	9-7/8	14-5/16	12-3/4	7-1/4	7-1/4

**General Installation Information:** True Union Swing Check valves are designed for horizontal installations, but may be installed in up-flow only vertical position. Check valves **MUST** be installed with the valves **FLOW** arrow pointing in the direction of the flow. Do not install valve upside down. Flow velocity should not exceed 5ft./sec. Minimum opening pressure less than 0.5 psi.

## Temperature Pressure Rating

System Operating Temperature °F (°C)			100 (38)	110 (43)	120 (49)	130 (54)	140 (60)	150 (66)	160 (71)	170 (77)	180 (82)	190 (88)	200 (93)	210 (99)
Valve Pressure Rating psi (MPa)	1/2" - 4"	PVC	150 (1.03)	135 (.93)	110 (.76)	75 (.52)	50 (.34)	-0- (-0-)	-0- (-0-)	-0- (-0-)	-0- (-0-)	-0- (-0-)	-0- (-0-)	-0- (-0-)
			150 (1.03)	140 (.97)	130 (.90)	120 (.83)	110 (.76)	100 (.70)	90 (.62)	80 (.55)	70 (.48)	60 (.41)	50 (.34)	-0- (-0-)



## Thermoplastic Valves Product Guide & Engineering Specifications

### Compression Utility Swing & Spring Check Valves



### Sample Engineering Specification

All thermoplastic check valves shall be Utility Compression Swing Check type constructed from PVC Type I, ASTM D 1784 Cell Classification 12454. All valves shall be maintenance free seal unit construction with EPDM seat and weighted disc. All valves shall have external flow arrow direction designation. All valves shall be certified by NSF International for use in potable water service. All valves shall be pressure rated to 150 psi for water @73°F in full flow (open) position and to 75 psi @ 73°F back pressure (closed), as manufactured by Spears® Manufacturing Company.

### Features - PVC White & PVC Clear

Spears® Compression Utility Swing Check Valves offer a compact, high performance check valve with EPDM gasketed compression-type ends for fast, convenient connection to virtual and IPS size pipe, plastic or metal. Maintenance-free sealed unit design features long-life EPDM elastomer seats and weighted disc for full flow with minimal restriction and positive shutoff. Produced from PVC White or PVC Clear with White compression end connectors and EPDM seats. Available in IPS Sizes 1/2" through 4".

- Standard Swing Check Assembly Maintains a Positive Seal
- Convenient Compression Ends for Quick Connections
- Engineered for Maximum Flow, Quick Response & Positive Shutoff
- Excellent for Pool & Spa, OEM and General Purpose Applications
- Compact, Space-Saving Design
- Replaceable PVC White or Clear Sealed Unit
- High Grade EPDM Seat
- Suitable for Horizontal or Vertical Up-flow Installations
- Pressure Rated to 150 psi @ 73°F Full Flow (open), 75 psi Back Pressure (closed)
- Maximum Service Temperature 140°F (temperature/pressure de-ratings apply)

### Quick-View Compression Utility Swing Check Valve Selection Chart

Valve Size	Seat Material	PVC Material <sup>1</sup> Compression	Pressure Rating
1/2	EPDM	S1500-05	150 psi @ 73°F Full Flow (Open)
3/4	EPDM	S1500-07	
1	EPDM	S1500-10	
1-1/4	EPDM	S1500-12	
1-1/2	EPDM	S1500-15	
2	EPDM	S1500-20	75 psi Back Pressure (Closed)
2-1/2	EPDM	S1500-25	
3	EPDM	S1500-30	
4	EPDM	S1500-40	

1: For PVC Clear, replace dash (-) separator with the letter "C" in the part number (e.g. S1500C05).



### Compression Coupling Nut Wrenches

Part Number	Size
CCW-005	1/2
CCW-007	3/4
CCW-010	1
CCW-012	1-1/4
CCW-015	1-1/2
CCW-020*	2
CCW-030**	3

\* CCW-020 - Wrench also fits 2-1/2" Coupling Body

\*\*CCW-030 - Wrench also fits 4" Coupling Body

### Compression Coupling Nut Wrench Sets

Part Number	Size
CCW-000	Set
Complete Set of Wrenches, Sizes 1/2" - 3"	

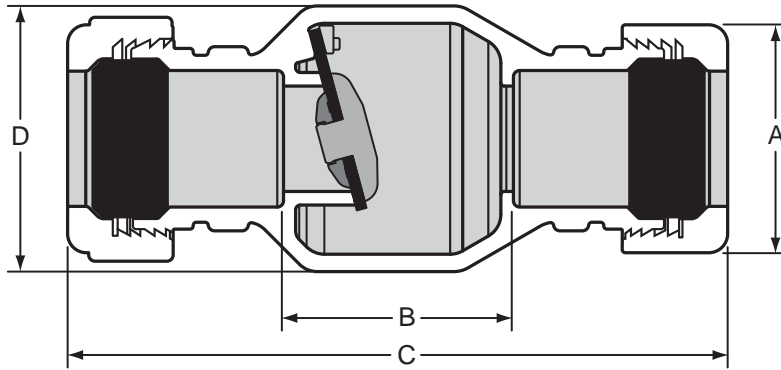

**FLOW**

**WARNING:** The compression joints provide a positive seal but do not restrain pipe from thrust and movement under pressure. Use of compression joint requires blocking of connecting pipe to prevent any movement. Failure to do so can result in system failure or severe personal injury. Use in cold water/fluid applications only.

### Dimensions

Nominal Size	Dimension Reference (inches, ± 1/16)			
	A	B	C	D
1/2	1-3/4	1-3/4	5-15/16	2-1/8
3/4	2-1/16	1-3/4	6	2-1/8
1	2-7/16	2-1/4	6-5/16	2-21/32
1-1/4	2-15/16	2-15/16	8-9/16	3-3/8
1-1/2	3-5/16	2-15/16	8-17/32	3-3/8
2	3-3/4	3-1/2	9-7/32	4-1/4
2-1/2	4-11/16	4-1/4	11-3/32	5-1/8
3	5-7/16	4-9/16	12-3/8	5-23/32
4	6-3/4	5-15/16	16-7/8	6-3/8



**General Installation Information:** Swing check valves are designed for horizontal installations, but may be installed in up-flow only vertical position. Check valves **MUST** be installed with the valve's **FLOW** arrow pointing in the direction of the flow. Do not install valve upside down. Flow velocity should not exceed 5 ft./sec. Minimum opening pressure less than 0.5 psi.

### Temperature Pressure Rating

System Operating Temperature °F (°C)			100 (38)	110 (43)	120 (49)	130 (54)	140 (60)	150 (66)	160 (71)	170 (77)	180 (82)	190 (88)	200 (93)	210 (99)
Valve Pressure Rating psi (MPa)	1/2" - 4"	PVC	150 (1.03)	135 (.93)	110 (.76)	75 (.52)	50 (.34)	-0- (-0-)	-0- (-0-)	-0- (-0-)	-0- (-0-)	-0- (-0-)	-0- (-0-)	-0- (-0-)
			150 (1.03)	140 (.97)	130 (.90)	120 (.83)	110 (.76)	100 (.70)	90 (.62)	80 (.55)	70 (.48)	60 (.41)	50 (.34)	-0- (-0-)



## Thermoplastic Valves Product Guide & Engineering Specifications

### Sump Pump Swing Check Valves



### Sample Engineering Specification

All thermoplastic check valves shall be Sump Pump Swing Check type constructed from PVC Type I, ASTM D 1784 Cell Classification 12454. All valves shall be maintenance free seal unit construction with EPDM seat and weighted disc. All valves shall have external flow arrow direction designation. All valves shall be dual-fit design with Buna-N Compression Gaskets for use with either IPS sizes 1-1/4" or 1-1/2" pipe. All valves shall be pressure rated to 150 psi @ 73°F in full flow (open) position and to 75 psi @ 73°F back pressure (closed), as manufactured by Spears® Manufacturing Company.

### Dimensions

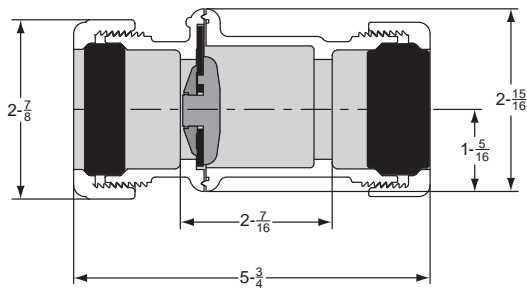

### Features - PVC White & PVC Clear

Spears® Sump Pump Swing Check Valves provide a high performance specialty valve engineered for use on sump pump discharge lines, as illustrated. This compact valve is a maintenance free sealed Check Valve featuring long-life EPDM elastomer seats and weighted disc for full-flow with minimal restriction and positive shutoff. Produced in PVC White with compression type end connectors. Dual-fit design is available with Buna-N Gaskets for both 1-1/4" and 1-1/2" pipe.

- All Plastic Construction with Elastomer Seals – No Metal Parts
- Includes Compression End Connectors with Buna-N Gaskets for Use on Either 1-1/4" or 1-1/2" Pipe
- Angled Seat and Weighted Flapper for Low-Pressure Seal
- Pressure Rated to 150 psi @ 73°F Full-Flow (open) and 75 psi @ 73°F Back Pressure (closed)
- Suitable for Vertical Up-flow or Horizontal Installations

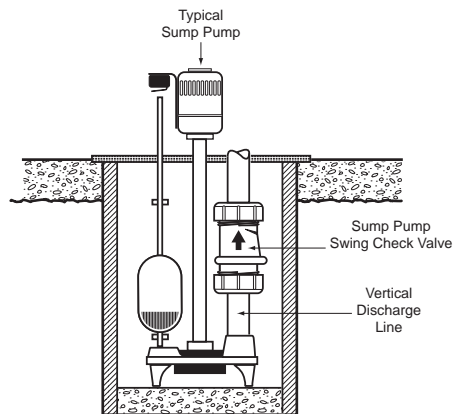

**General Installation Information:** Sump Pump Swing Check Valves may be installed in either vertical up-flow (see illustration) or horizontal positions on pump discharge line. Check valves **MUST** be installed with the valve's **FLOW** arrow pointing in the direction of the flow. In horizontal installations, the designated side must be positioned "up". Do Not install Check Valve upside down.

### Quick-View Sump Pump Swing Check Valve Selection Chart

Valve Size	Seat Material	PVC Material <sup>1</sup>	Pressure Rating
		Socket	
1-1/4 & 1-1/2	EPDM	S1400-15	150 psi @ 73°F Full Flow (Open) 75 psi Back Pressure (Closed)

1: For PVC Clear Sump Pump, replace dash (-) separator with the letter "C" in the part number (e.g., S1400C15)



### Sample Engineering Specification

All thermoplastic check valves shall be Swing Check Ball Valve combination type constructed from PVC Type I, ASTM D 1784 Cell Classification 12454. All Ball Valve units shall have Safe-T-Shear® stem, Safe-T-Blocked® Seal Carrier and double stop Polypropylene handle. All valve components shall be replaceable. All Swing Check Units shall be maintenance free seal unit construction with EPDM seat and weighted disc. All valves shall have external flow arrow designation. All valves shall be pressure rated to 150 psi for water @73°F in full flow (open) position and to 75 psi @ 73°F back pressure (closed), as manufactured by Spears® Manufacturing Company.

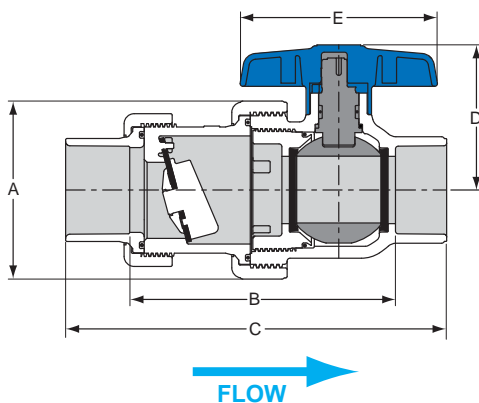

### Dimensions

Size	A	B	C	D	E
1-1/2	3-7/8	5-3/4	8-1/4	3-3/16	4-1/4
2	4-7/16	6-11/16	9-3/8	3-7/8	5-1/16

### Features - PVC White

Spears® Swing Check Ball Valve offers a compact, high performance one-piece combination valve for applications requiring an in-line Ball Valve and Check Valve. This space, time and labor saving valve is designed for general purpose use and in wastewater pumping applications, such as ejector pits. Provides quick shut-off for easy pump or equipment servicing. Fully serviceable Ball Valve with replaceable, maintenance free sealed Check Valve Cartridge featuring long-life EPDM elastomer seats and weighted disc for full-flow with minimal restriction and positive shutoff. Produced in PVC White with socket end connectors. Available in IPS sizes 1-1/2" and 2".

- Compact, Space-Saving Design
- Union Design Allows Easy Service and Cleaning
- High Grade EPDM Seals
- Replaceable PTFE/HDPE Ball Valve Seats
- Safe-T-Blocked® Seal Carrier on Ball Valve with Safe-T-Shear® Stem and High Impact Polypropylene Handle
- Replaceable Sealed Check Valve Cartridge with Weighted EPDM Seat
- Pressure Rated to 150 psi @ 73°F Full-Flow (open) and 75 psi @ 73°F Back Pressure (closed)
- Suitable for Horizontal or Vertical Up-flow Installations

**General Installation Information:** Swing Check Ball Valves are designed for horizontal installations, but may be installed in up-flow only vertical position. The Check Valve portion **MUST** be installed with the valve's **FLOW** arrow pointing in the direction of flow and with the designated side up in horizontal installations. Do Not install Check Valve upside down. The Ball Valve portion may be rotated and installed in any position. Flow velocity should not exceed 5 ft./sec. Minimum opening pressure is less than 0.5 psi.



### Quick-View Swing Check Ball Valve Selection Chart

Valve Size	Seat Material	PVC Material Socket	Pressure Rating
1-1/2	EPDM	7622-015	150 psi @ 73°F Full Flow (Open)
2	EPDM	7622-020	75 psi Back Pressure (Closed)



## Y-Check Valves



### Sample Engineering Specification

All thermoplastic valves shall be Y-Check configuration manufactured to ASTM F 1970 and constructed from PVC, ASTM D 1784 Cell Classification 12454, or CPVC, ASTM D 1784 Cell Classification 23447. All valves shall have Buttress thread bonnet and standard O-ring type seating disc. All O-rings shall be EPDM or FKM. All 1/2" - 2" valves shall be pressure rated at 150 psi and all 3" - 4" valves shall be pressure rated at 90 psi for water at 73°F, as manufactured by Spears® Manufacturing Company.

### Features - PVC Gray, PVC Clear & CPVC

Spears® Y-Check Valves are an angle type check valve that automatically stops reverse flow by the dead weight of the disc plug. Y-checks are less affected by turbulent flow and typically have lower shutoff characteristics than ball checks. Valves are available in PVC Gray, PVC Clear, and CPVC materials in IPS Sizes 1/2" through 4" with Socket, SR Threaded or Flanged end connections, plus True Union styles with Socket and SR Threaded ends.

- Chemical & Corrosion Resistant PVC, PVC Clear, and CPVC Construction
- Improved Flow Characteristics Over Ball Checks, Outperforms Spring Loaded Designs
- Easy Access Cap for In-Line Clean Out & Servicing
- Optional True Union Design for Easy Valve Service Replacement
- Standard O-ring type EPDM or FKM Seat & Seals
- Sizes 1/2" – 2" Pressure Rated to 150psi @ 73°F, Sizes 3" – 4" Pressure Rated to 90 psi @ 73°F
- Suitable for either Horizontal or Vertical Up-flow Installations
- Assembled with Silicone-Free, Water Soluble Lubricants

### Quick-View Valve Selection Chart

Valve Size	O-ring Material	PVC Part Number <sup>1,2,3</sup>					Pressure Rating
		Socket	SR Threaded	Flanged	Soc Union	SR Thd Union	
1/2	EPDM	1622-005	1621-005SR	1623-005	162A-005	162B-005SR	150 psi Non-Shock Water @ 73°F
	FKM	1632-005	1631-005SR	1633-005	163A-005	163B-005SR	
3/4	EPDM	1622-007	1621-007SR	1623-007	162A-007	162B-007SR	
	FKM	1632-007	1631-007SR	1633-007	163A-007	163B-007SR	
1	EPDM	1622-010	1621-010SR	1623-010	162A-010	162B-010SR	
	FKM	1632-010	1631-010SR	1633-010	163A-010	163B-010SR	
1-1/4	EPDM	1622-012	1621-012SR	1623-012	162A-012	162B-012SR	
	FKM	1632-012	1631-012SR	1633-012	163A-012	163B-012SR	
1-1/2	EPDM	1622-015	1621-015SR	1623-015	162A-015	162B-015SR	
	FKM	1632-015	1631-015SR	1633-015	163A-015	163B-015SR	
2	EPDM	1622-020	1621-020SR	1623-020	162A-020	162B-020SR	
	FKM	1632-020	1631-020SR	1633-020	163A-020	163B-020SR	
3	EPDM	1622-030	1621-030SR	1623-030	162A-030	162B-030SR	90 psi Non-Shock Water @ 73°F
	FKM	1632-030	1631-030SR	1633-030	163A-030	163B-030SR	
4	EPDM	1622-040	1621-040SR	1623-040	162A-040	162B-040SR	
	FKM	1632-040	1631-040SR	1633-040	163A-040	163B-040SR	

1: For CPVC Y-Check, add the letter "C" to the part number (e.g. 1622-005C)  
 2: For PVC Clear Y-Check, add the letters "CL" to the part number (e.g. 1622-005CL) or (e.g. 162A-005CL)  
 3: For CPVC or PVC Clear Special Reinforced Y-Check, (e.g. 1621-005CSR) or (e.g. 1621-005CLSR)

### Replacement Parts (next page)

NO.	COMPONENT	QTY.	MATERIAL
1	Body <sup>1</sup> (SOC/SR/FLG/UNION)	1	PVC/CLEAR/CPVC
2	Seat	1	EPDM/FKM
3	Compressor Assembly <sup>2</sup>	1	PVC/CPVC
4	Bonnet O-ring	1	EPDM/FKM
5	Bonnet Nut	1	PVC/CPVC
6	Bonnet	1	PVC/CPVC
7	Retaining Clip	1	PP
8	Plug O-ring	1	EPDM/FKM
9	Plug	1	PVC/CPVC
10	Union O-ring	2	EPDM/FKM
11	Union Socket End	2	PVC/CPVC
12	Union SR Threaded End	2	PVC/CPVC

1 - Body Includes: Body (1), Spigot Adapters (2), SS Collars (2)  
 - Flange Body Includes: Body (1), Spigot Hubs (2), Flange Rings (2)  
 - Union Body Includes: Body (1), Spigot Ends (2), Nuts (2)

2 - Compressor Assembly Includes: Compressor (1), Weight (1), Compressor Plug (1)

### Temperature Pressure Rating

System Operating Temperature °F (°C)		100 (38)	110 (43)	120 (49)	130 (54)	140 (60)	150 (66)	160 (71)	170 (77)	180 (82)	190 (88)	200 (93)	210 (99)
Valve Pressure Rating psi (MPa)	1/2" - 2"	PVC	150 (1.03)	135 (.93)	110 (.76)	75 (.52)	50 (.34)	-0-	-0-	-0-	-0-	-0-	-0-
		CPVC	150 (1.03)	140 (.97)	130 (.90)	120 (.83)	110 (.76)	100 (.70)	90 (.62)	80 (.55)	70 (.48)	60 (.41)	50 (.34)
	3" - 4"	PVC	90 (.70)	85 (.62)	75 (.52)	60 (.41)	40 (.30)	-0-	-0-	-0-	-0-	-0-	-0-
		CPVC	90 (.70)	85 (.62)	80 (.55)	75 (.52)	70 (.48)	60 (.41)	50 (.34)	45 (.31)	40 (.30)	35 (.24)	30 (.21)

### Cv Values

Size	Values
1/2	6.7
3/4	12.6
1	22.9
1-1/4	33.8
1-1/2	50.7
2	79.2
3	235
4	387

# Y-Check Valves

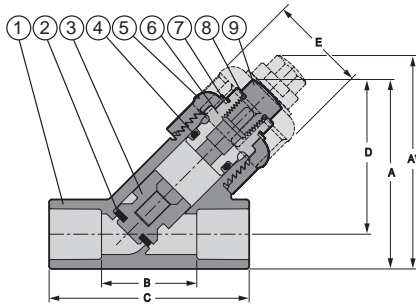

## Socket Y-Check Dimensions & Weights

Nominal Size	Dimension Reference (inches, ± 1/16)						Approx. Wt. (Lbs.)	
	A <sup>1</sup>	A	B	C	D	E	Socket	
							PVC	CPVC
1/2	4-1/32	3-5/32	1-19/32	3-11/32	2-19/32	1-5/8	.31	.33
3/4	4-27/32	3-27/32	2	4	3-5/32	2	.50	.53
1	5-5/8	4-1/2	2-15/32	4-23/32	3-5/8	2-1/4	.85	.90
1-1/4	6-1/2	5-5/16	3-1/32	5-9/16	4-9/32	2-13/16	1.21	1.28
1-1/2	7-17/32	6-1/32	3-19/32	6-5/16	4-7/8	3-5/32	1.66	1.76
2	8-15/32	6-29/32	4-31/32	7-1/2	5-1/2	3-23/32	2.96	3.10
3	12-15/32	9-21/32	6-9/16	10-11/32	7-9/16	5-1/4	5.34	5.64
4	15-17/32	12-11/16	8-5/8	13-1/8	9-25/32	6-17/32	9.97	10.45

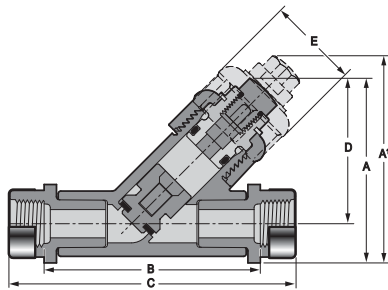

## SR Threaded Y-Check Dimensions & Weights

Nominal Size	Dimension Reference (inches, ± 1/16)						Approx. Wt. (Lbs.)	
	A <sup>1</sup>	A	B	C	D	E	SR Threaded	
							PVC	CPVC
1/2	4-5/32	3-9/32	3-27/32	5-1/8	2-19/32	1-5/8	.31	.33
3/4	5	4	4-3/4	5-31/32	3-5/32	2	.50	.53
1	5-25/32	4-21/32	5-9/32	6-15/16	3-5/8	2-1/4	.85	.90
1-1/4	6-23/32	5-1/2	6-1/4	7-31/32	4-9/32	2-13/16	1.21	1.28
1-1/2	7-25/32	6-9/32	7-5/32	8-7/8	4-7/8	3-5/32	1.66	1.76
2	8-3/4	7-3/16	8-5/16	10-1/8	5-1/2	3-23/32	2.96	3.10
3	12-3/4	9-15/16	11-17/32	14-5/16	7-9/16	5-1/4	5.34	5.64
4	15-25/32	12-11/16	14-11/32	17-11/32	9-25/32	6-17/32	9.97	10.45

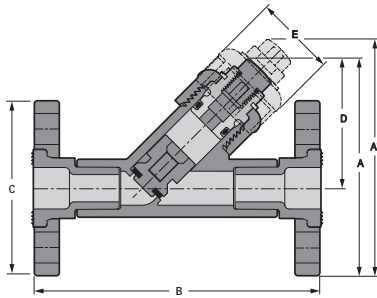

## Flanged Y-Check Dimensions & Weights

Nominal Size	Dimension Reference (inches, ± 1/16)						Approx. Wt. (Lbs.)	
	A <sup>1</sup>	A	B	C	D	E	Flanged	
							PVC	CPVC
1/2	5-7/32	4-11/32	5-23/32	3-1/2	2-19/32	1-5/8	.82	.85
3/4	6-1/16	5-3/32	6-7/16	3-7/8	3-5/32	2	1.23	1.28
1	6-7/8	5-3/4	7-5/32	4-1/4	3-5/8	2-1/4	1.70	1.81
1-1/4	7-25/32	6-9/16	8-1/8	4-5/8	4-9/32	2-13/16	2.40	2.52
1-1/2	8-7/8	7-3/8	9-5/32	5	4-7/8	3-5/32	3.07	3.25
2	10-1/32	8-15/32	10-1/2	5-31/32	5-1/2	3-23/32	5.20	5.42
3	13-29/32	11-5/16	12-1/16	7-1/2	7-9/16	5-1/4	9.44	10.07
4	17-13/32	14-5/16	15-11/16	9-1/16	9-25/32	6-17/32	14.87	16.15

Note: 4" flanged Y-Check use split flange ring

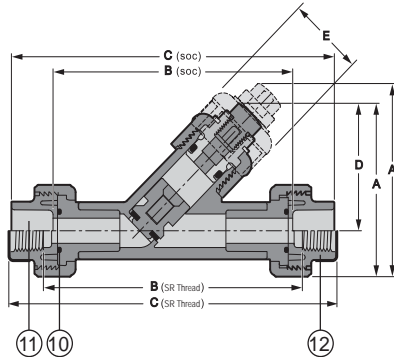

## True Union Y-Check Dimensions & Weights

Nominal Size	Dimension Reference (inches, ± 1/16)						Approx. Wt. (Lbs.)			
	A <sup>1</sup>	A	B		C		D	E	Union	
			Socket	SR Thread	Socket	SR Thread			PVC	CPVC
1/2	4-3/8	3-1/2	5-3/32	5-1/2	6-7/8	7	2-19/32	1-5/8	.49	.53
3/4	5-5/16	4-9/32	5-7/8	6-13/32	7-29/32	8	3-5/32	2	.80	.85
1	6-1/16	4-29/32	6-15/32	7-5/16	8-3/4	9	3-5/8	2-1/4	1.13	1.20
1-1/4	7-1/16	5-13/16	7-7/16	8-7/32	10-1/8	10-5/32	4-9/32	2-13/16	1.84	1.90
1-1/2	8-1/8	6-5/8	8-1/4	9	11	11-1/16	4-7/8	3-5/32	2.44	2.52
2	9-7/32	7-5/8	9-13/32	10-13/16	12-7/16	12-13/16	5-1/2	3-23/32	4.33	4.45
3	13-7/16	10-5/8	13-5/8	15-11/32	17-13/32	18-7/32	7-9/16	5-1/4	10.35	10.55
4	16-3/4	13-5/8	17-3/32	19-9/32	21-21/32	22-5/16	9-25/32	6-17/32	18.51	18.80

## Drain Plug Tap Size

Y-Check Size	Tap Size (NPT)	Y-Check Size	Tap Size (NPT)
1/2	1/4 - 18	1-1/2	1-11-1/2
3/4	1/4 - 18	2	1-11-1/2
1	3/8 - 18	3	1-11-1/2
1-1/4	1/2 - 14	4	1-11-1/2



## Butterfly Check Valves



### Features – PVC, CPVC

This multi-purpose check valve provides an extremely low profile and very quick response to back flow without slamming. Since most all components are internal, Spears® Butterfly Check Valves require no more space than a piece of pipe and fitting. Special design incorporates flexible reinforced elastomer seal for long life and is suitable for mounting in any position for greater versatility. Available in IPS sizes 2" - 12" with Flanged, Spigot, Male Threaded, Grooved Pipe style & Wafer end connections, and 14" - 24" Flanged, Spigot, Grooved & Wafer end connections. Can be custom produced to virtually any standard pipe diameter.

- Chemical Resistant PVC & CPVC Construction
- No Metal Components
- Quick Response Shut-off In Any Position
- Replaceable Internal Components - Choice of Reinforced EPDM or FKM
- Suitable for Horizontal or Vertical Installation
- Sizes 2" - 8" Pressure Rated to 150 psi for water at 73°F
- Sizes 10" - 14" Pressure Rated to 100 psi for water at 73°F
- Sizes 16" Pressure Rated to 70 psi for water at 73°F
- Sizes 18" - 24" Pressure Rated to 50 psi for water at 73°F
- Assembled with Silicone-Free, Water Soluble Lubricants

### Sample Engineering Specification

All thermoplastic Check Valves shall be Butterfly design constructed from PVC Type I, ASTM D 1784 Cell Classification 12454 or CPVC Type IV, ASTM D 1784 Cell classification 23447. Valves shall be Flanged, Spigot, Male Threaded, Grooved end or Wafer style. All valve seals shall be reinforced EPDM or FKM with replaceable internal components. All 2" - 8" valves shall be pressure rated at 150 psi, all 10" - 14" valves at 100 psi for water at 73°F, 16" valves at 70 psi and all 18" - 24" valves at 50 psi for water at 73°F as manufactured by Spears® Manufacturing Company.

Thermoplastic Valves Product Guide & Engineering Specifications  
**Butterfly Check Valves**



**Quick-View Butterfly Check Valve Selection Chart**

**C<sub>v</sub> Values**

Valve Size	O-ring Material	PVC Material <sup>1</sup>					Pressure Rating
		Flanged	Spigot	Threaded	Grooved	Wafer	
2	EPDM	5423-020	5427-020	5421A-020	542G-020	5420-020	150 psi Non-Shock Water @73°F
	FKM	5433-020	5437-020	5431A-020	543G-020	5430-020	
2-1/2	EPDM	5423-025	5427-025	5421A-025	542G-025	5420-025	
	FKM	5433-025	5437-025	5431A-025	543G-025	5430-025	
3	EPDM	5423-030	5427-030	5421A-030	542G-030	5420-030	
	FKM	5433-030	5437-030	5431A-030	543G-030	5430-030	
4	EPDM	5423-040	5427-040	5421A-040	542G-040	5420-040	
	FKM	5433-040	5437-040	5431A-040	543G-040	5430-040	
6	EPDM	5423-060	5427-060	5421A-060	542G-060	5420-060	
	FKM	5433-060	5437-060	5431A-060	543G-060	5430-060	
8	EPDM	5423-080	5427-080	5421A-080	542G-080	5420-080	
	FKM	5433-080	5437-080	5431A-080	543G-080	5430-080	
10	EPDM	5423-100	5427-100	5421A-100	542G-100	5420-100	100 psi Non-Shock Water @73°F
	FKM	5433-100	5437-100	5431A-100	543G-100	5430-100	
12	EPDM	5423-120	5427-120	5421A-120	542G-120	5420-120	
	FKM	5433-120	5437-120	5431A-120	543G-120	5430-120	
14	EPDM	5423-140	5427-140	N/A	542G-140	5420-140	
	FKM	5433-140	5437-140	N/A	543G-140	5430-140	
16	EPDM	5423-160	5427-160	N/A	542G-160	5420-160	70 psi
	FKM	5433-160	5437-160	N/A	543G-160	5430-160	
18	EPDM	5423-180	5427-180	N/A	542G-180	5420-180	50 psi Non-Shock Water @73°F
	FKM	5433-180	5437-180	N/A	543G-180	5430-180	
20	EPDM	5423-200	5427-200	N/A	542G-200	5420-200	
	FKM	5433-200	5437-200	N/A	543G-200	5430-200	
24	EPDM	5423-240	5427-240	N/A	542G-240	5420-240	
	FKM	5433-240	5437-240	N/A	543G-240	5430-240	

Size	C <sub>v</sub> <sup>1</sup>
2	91
2-1/2	123
3	365
4	665
6	1695
8	2990
10	5595
12	8490
14	10,000
16	13,000
18	15,000
20	18,000
24	29,000

1: Gallons per minute at 1 psi pressure drop.

1: For CPVC valves add the letter "C" following the size code of the part number listed (e.g., 5423-020C)

**Temperature Pressure Rating**

System Operating Temperature °F (°C)		100 (38)	110 (43)	120 (49)	130 (54)	140 (60)	150 (66)	160 (71)	170 (77)	180 (82)	190 (88)	200 (93)	210 (99)	
Valve Pressure Rating psi (MPa)	2" - 8"	PVC	150 (1.03)	135 (.93)	110 (.76)	75 (.52)	50 (.34)	-0-	-0-	-0-	-0-	-0-	-0-	
		CPVC	150 (1.03)	140 (.97)	130 (.90)	120 (.83)	110 (.76)	100 (.70)	90 (.62)	80 (.55)	70 (.48)	60 (.41)	50 (.34)	-0-
	10" - 16"	PVC	100 (.70)	90 (.62)	80 (.55)	65 (.38)	50 (.34)	-0-	-0-	-0-	-0-	-0-	-0-	-0-
		CPVC	100 (.70)	95 (.66)	90 (.62)	85 (.59)	80 (.55)	75 (.52)	70 (.48)	65 (.45)	60 (.41)	55 (.38)	50 (.34)	-0-
	18" - 24"	PVC	50 (.34)	45 (.31)	40 (.30)	35 (.24)	30 (.21)	-0-	-0-	-0-	-0-	-0-	-0-	-0-
		CPVC	50 (.34)	47 (.32)	45 (.31)	42 (.83)	40 (.30)	37 (.26)	35 (.24)	30 (.21)	25 (.17)	20 (.14)	15 (.10)	-0-





## Thermoplastic Valves Product Guide & Engineering Specifications

### Butterfly Check Valves

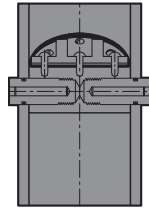
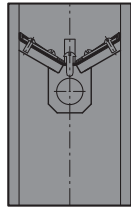
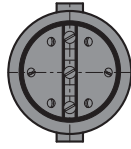

### Replacement Parts

No.	Component	Qty.	Material
1	Body	1	PVC/CPVC
2	Flapper	2	PVC/CPVC
3	Flex Seal Gasket	1	EPDM/FKM
4	Flapper Cover	2	PVC/CPVC
5	Flapper Screws	6	PVC/CPVC
6	Hinge Post Screws	3	Encapsulated SS
7	Post Strip	1	PVC/CPVC
8	Post Bolt	3	PVC/CPVC (Steel Reinforced)
9	O-ring	2	EPDM/FKM
10	Hinge Post	1	PVC/CPVC

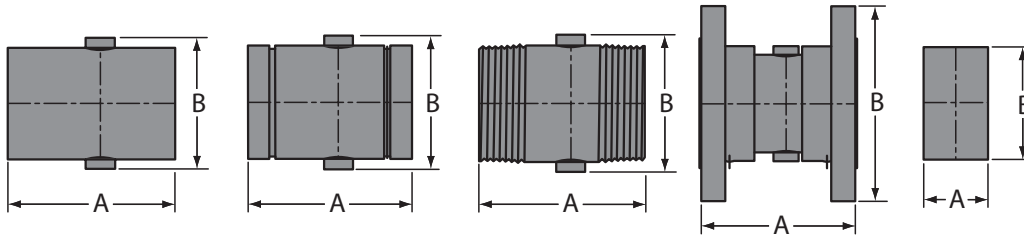

### Dimensions

Size	Spigot (Plain End) Valve, Grooved End Valve & Threaded Valve		Flanged		Wafer		Pressure Rating (psi)
	A	B	A	B	A	B	
2	5-3/4	2-9/16	6-1/16	6	1-3/4	4	150
2-1/2	5-3/4	3-3/32	6-1/8	7	2-3/8	4-3/4	150
3	5-3/4	4-1/32	6-1/4	7-1/2	2-3/4	5-1/4	150
4	6-3/4	4-13/16	7-1/4	9	3-5/8	6-5/8	150
6	10-1/2	7-9/32	11-3/8	11	4-1/4	8-5/8	150
8	14	10-7/32	14-9/16	13-1/2	6	11	150
10	16	11-31/32	17-3/8	16	10	13-1/4	100
12	16	14-1/32	17-1/4	19	12	16	100
14	18	14-3/4	20	21	13	17-5/8	100
16	19-3/4	16-17/32	21-1/4	23-1/2	13-1/2	20-1/8	70
18	26-1/2	19-31/32	27	25	15-1/2	21-1/2	50
20	28-7/8	21-25/32	40-7/8	27-1/2	17	23-3/4	50
24	29-7/8	25-21/32	43-7/8	32	19	24	50

As a general guideline, Opening & Closing Pressures will range from .2 to .5 psi for horizontal applications. Opening pressure tends to decrease in larger size valves. Valves installed in vertical up-flow applications will require slightly higher pressures.

### General Installation Information

Butterfly Check Valve seating may be affected by normal system turbulence. Valves should be installed at least 5 pipe diameters away from any fitting. If used as a foot valve, do not place near bottom of a tank. Butterfly type check valves should not be used in continuous cycling applications, such as with reciprocating pumps. This can result in premature failure of sealing membrane. In horizontal installations, always orient the Hinge Post Bolts visible on the external body in a vertical (top and bottom) position, perpendicular to flow. In vertical installations downstream from an elbow, flow velocities can be higher on the outer radius of the elbow. To avoid uneven butterfly plate loading, the Hinge Post Bolts should align with crotch and outer radius of elbow and **NOT** from side to side of the elbow.

**Notes:** Flanged valves are designed for mounting between two (2) ANSI Class 125/150 bolt pattern flanges using user supplied 1/8" full-faced gaskets, bolts, nuts and flat washers. Male thread ends are standard NPT tapered. Grooved ends are for use with mechanical coupler designed for thermoplastic pipe.



### Features – PVC, CPVC

Spears® Diaphragm Check Valves do not depend on gravity, springs, or even reverse flow to seat. Resilient thermoplastic elastomer (TPE) diaphragm is the only moving component, which automatically seats when flow stops. No sticking, no chatter. This specialty elastomer exhibits high flex and tear resistance to provide excellent durability and long life. Valves are available in PVC and CPVC material size of 3/4" with socket and threaded end connections.

- “Normally Closed” operation is excellent for applications with low seating pressure
- Low cracking pressure, 1 to 1-1/2 psi
- Leak-free, silent operation
- Installs just like a Union – in ANY position
- Pressure rated to 150 psi full-flow (open), 100 psi back pressure (closed) for water @ 73°F
- Santoprene™ TPE diaphragm seat provides extended life and durability – fully serviceable and replaceable
- All materials are NSF® Certified for use with potable water

### Sample Engineering Specification

All thermoplastic Diaphragm Check Valves shall be Diaphragm design constructed from PVC Type 1, ASTM D 1784 Cell Classification 12454 or CPVC Type IV, ASTM D 1784 Cell Classification 23447. Valves shall be socket or threaded ends. All diaphragms shall be Santoprene™ TPE material. Valves shall be pressure rated at 150 psi full-flow (open), 100 psi back pressure (closed) for water @ 73°F, as manufactured by Spears® Manufacturing Company.

### Quick-View Diaphragm Check Valve Selection Chart

Valve Size	Seat Material	PVC Material <sup>1</sup>		Pressure Rating
		Socket	Threaded	
3/4	SANTOPRENE™	6562-007	6561-007	150 psi @ 73°F Full Flow (open) 100 psi Back Pressure

1: For CPVC Diaphragm Check Valve, add the letter "C" to the part number (e.g. 6562-007C)

### Replacement Parts

No.	Component	Qty	Material
1	Body Inlet	1	PVC/CPVC
2	Diaphragm	1	Santoprene™ Rubber
3	Nut	1	PVC/CPVC
4	Body Outlet	1	PVC/CPVC

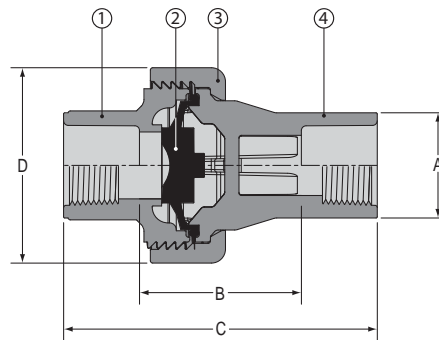

### Dimensions & Weights

Nominal Size	Dimension Reference (inches, ±1/16)					Approx. Wt. (Lbs.)	
	A	B		C	D	PVC	CPVC
		Socket	Threaded				
3/4	1-7/16	2-1/8	2-5/8	4-1/8	2-21/32	.32	.34

**NOTE:** Check valves **MUST** be installed with the valve's **FLOW** arrow pointing in the direction of the flow. Flow velocity should not exceed 5 ft./sec. Do not use Union Nut to draw together system components. Using a strap wrench, tighten hand-tight plus no more than 1/16 turn. Do not use conventional pipe wrenches.

Santoprene™ is a trademark of Exxon Mobil Corporation



## Thermoplastic Valves Product Guide & Engineering Specifications

### In-Line Adjustable Spring Check Valves



### Features - PVC

Adjustable feature allows control of back pressure in system, reduces water hammer, and prevents siphoning. Easily adjusts to hold back from 5 to 32 feet of pressure head, 1 psi (2.3 feet of head) for each full turn of the adjustment screw. Ideal for landscape and irrigation applications, quickly installs with space saving in-line design.

- 2 - 14 lbs. Adjustable Spring Tension (5 to 32 feet of head) Factory Preset to Approx. 5 psi (12 feet of head)
- Stainless Steel Adjustment Spring with EPDM Seat
- Pressure Rated to 200 psi for Water @ 73°F
- Standard Unit Available in 1/2", 3/4", 1" & 1/2" x 3/4" with Fipt Inlet x Mipt Outlet Configuration
- Plus, Popular Configuration Options of 1/2" Mipt Inlet x Fipt Outlet & 3/4" Fipt Inlet x Fipt Outlet

### Sample Engineering Specification

All thermoplastic check valves shall be Adjustable Spring Check type constructed from PVC Type I, ASTM D 1784 Cell Classification 12454. All Valve Seats shall be EPDM. All valves shall have external Arrow Flow Indicator. All valves shall be pressure rated to 200 psi water at 73°F, as manufactured by Spears® Manufacturing Company.



### Quick-View Valve Selection Chart

Standard Unit - Female Inlet x Male Outlet		
Size	Part Number	Configuration
1/2	S1102-05	Fipt x Mipt (Inlet x Outlet)
3/4	S1102-07	Fipt x Mipt (Inlet x Outlet)
1	S1102-10	Fipt x Mipt (Inlet x Outlet)
1/2 x 3/4	S1102-05-07	Fipt x Mipt (Inlet x Outlet)
Male Inlet x Female Outlet Option		
Size	Part Number	Configuration
1/2	S1101-05	Mipt x Fipt (Inlet x Outlet)
Female Inlet x Female Outlet Option		
Size	Part Number	Configuration
3/4	S1100-07	Fipt x Fipt (Inlet x Outlet)

# Thermoplastic Valves Product Guide & Engineering Specifications

## In-Line Adjustable Spring Check Valves

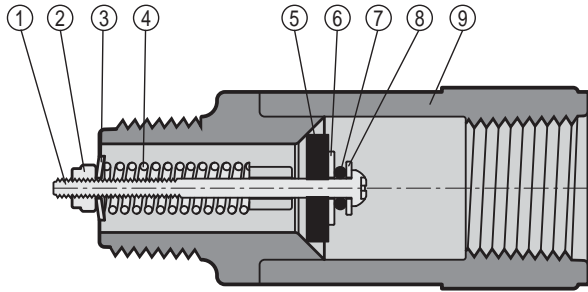

### Replacement Parts

No.	Component	Qty.	Material
1	Screw	1	Stainless Steel
2	Nut	1	Stainless Steel
3	Belleville Washer	1	Stainless Steel
4	Spring	1	Stainless Steel
5	Seat	1	EPDM
6	Washer - A	1	Stainless Steel
7	O-ring	1	EPDM
8	Washer - B	1	Stainless Steel
9	Body	1	PVC

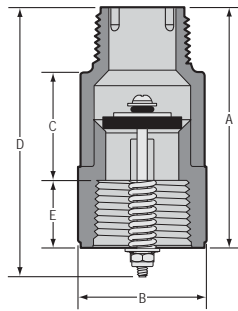

FIG. I  
Standard Unit Female Inlet x  
Male Outlet

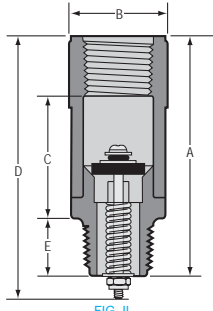

FIG. II  
Male Inlet x  
Female Outlet Option

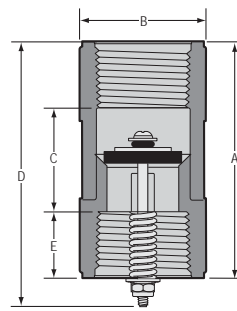

FIG. III  
Female Inlet x  
Female Outlet Option



### Dimensions

SIZE	INLET X OUTLET	A ± 1/16	B ± 1/16	C ± 1/16	D ± 1/16	E ± 1/16	FIG.
1/2	FIPT X MIPT	2-5/8	1-3/16	1-3/16	2-3/4	3/4	I
3/4	FIPT X MIPT	2-5/8	1-3/8	1-3/16	2-15/16	3/4	I
1	FIPT X MIPT	3-3/16	1-11/16	1-7/16	3-7/16	7/8	I
1/2 x 3/4	FIPT X MIPT	2-5/8	1-3/8	1-3/16	2-15/16	3/4	I
1/2	MIPT X FIPT	2-7/8	1-3/16	1-7/16	3-1/8	3/4	II
3/4	FIPT X FIPT	2-5/8	1-3/8	1-3/16	2-15/16	3/4	III

### Temperature Pressure Rating

System Operating Temperature °F (°C)			100 (38)	110 (43)	120 (49)	130 (54)	140 (60)	150 (66)	160 (71)	170 (77)	180 (82)	190 (88)	200 (93)	210 (99)
Valve Pressure Rating psi (MPa)	1/2"-1"	PVC	200 (1.38)	135 (.93)	120 (.83)	75 (.52)	50 (.34)	-0- (-0-)	-0- (-0-)	-0- (-0-)	-0- (-0-)	-0- (-0-)	-0- (-0-)	-0- (-0-)



## Eliminates Noise in Sump Pump and Sewage Ejector Check Valve Operation



Spears® Quiet Check Valve has been designed to provide quiet operation in sump pump or sewage ejector pump systems typically found in home basements. The back flow of the water column in the discharge pipe can slam conventional check valves closed, producing a disturbing “thump” when the pump shuts off. The Quiet Check Valve uses a spring controlled rate of closing to prevent slamming and eliminates the noise.

Each Spears® Quiet Check Valve contains both regular socket ends for direct solvent cement connection of the valve and True Union style end connectors for easy valve removal or replacement.

Produced in both 1-1/2" and 2" nominal sizes, the 2" size is the minimum recommended for a sewage discharge system (i.e., sewage ejector pump) while the 1-1/2" size can be used in an effluent system (i.e., sump pump) discharge line to prevent back flow of liquid into sump basin.

**Pressure Rating @ 73°F (23°C), Water**  
**Full Flow (open) 150 psi**  
**Back Pressure (closed) 75 psi**  
**Maximum Service Temperature**  
**140°F (60°C)**  
**Temperature/Pressure De-ratings Apply**

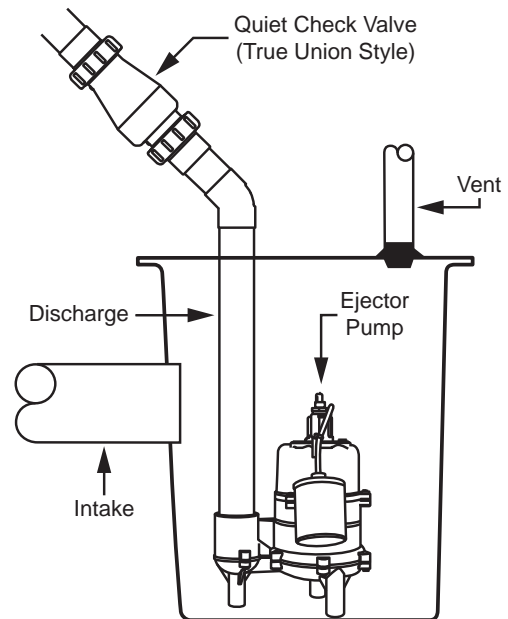

**Typical Application**

## Quiet Check Valves



### Technical Information

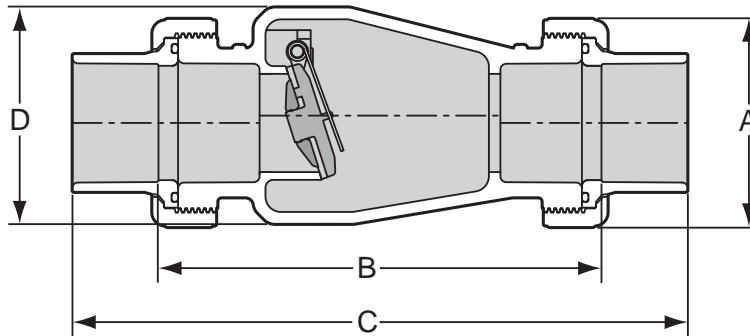

True Union Socket Connection

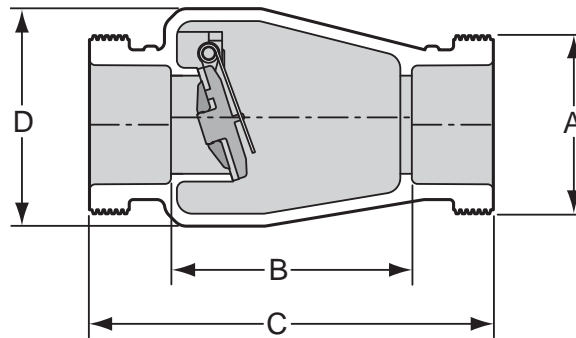

Direct Socket Connection

FLOW



#### True Union Socket Connection

Part Number	Size	A	B	C	D
8622-015	1-1/2	3-3/8	7-1/8	9-15/16	3-1/2
8622-020	2	3-3/4	8-3/4	11-13/16	4-1/2

#### Direct Socket Connection

Part Number	Size	A	B	C	D
8622-015	1-1/2	2-3/4	3-13/16	6-1/2	3-1/2
8622-020	2	3-3/8	5-3/16	8	4-1/2

**Note:** Includes Both True Union Sockets for Easy Servicing and Direct Socket Connection for Installation in Confined Space

The check valve should be installed 12–18" above the pump discharge, or as recommended by the pump system manufacturer. Be sure check valve installation complies with local codes.

The Quiet Check Valve may be installed in either horizontal or vertical position. Check pump system manufacturer's recommendations for horizontal, vertical or angled positioning of check valve in discharge line. In horizontal installations, orient valve according to "This Side Up" marking for best operation. In all installations, valve **MUST** be installed in proper flow direction as indicated by the flow arrow on body.



**Basic Valve**

- All PVC Construction with EPDM Flapper Seal
- Threaded Top Plug for Convenient Service
- Simple Snap-In Internal Flapper Assembly for Easy Replacement
- Optional Factory Assembled Service-Access Extension Kits - External Housing with Internal Extension for Convenient Removal, Inspection or Replacement
- Optional Extension Components Kits for Assembly with User-Supplied Pipe
- Available in Sizes 2", 3", 4" and 6" with Socket Ends
- Direct Connection to ASTM D 2665 PVC DWV or other IPS size pipe. Spears® IPS x Sewer Adapters Available for Connection to ASTM 3034 Sewer
- Conforms to ASME/ANSI A112.14.1 for Backwater Valves
- Pressure Rated to 43 psi (100 feet of head) @ 73°F

**Features - PVC Gray**

Backwater Valves are designed to prevent backflow in numerous applications where easy service access for maintenance and cleaning is needed. Excellent for use in sanitary or storm sewer drainage systems to prevent waste back up due to inadequate drainage, for balancing multi-level ponds, aquaculture features or storage tank systems, and many other applications. Spears® Backwater Valve has been engineered for improved function and easier service, especially in buried service with use of optional Service-Access Extension Kit.



**Valve with Extension Kit**

**PVC Service-Access Extension Kit Options:**

Available as a complete unit, with or without valve, factory assembled to internal flap assembly, extension pipe, and external extension housing with top access adapter in convenient increments of 12", 16", 20", 24", 36", and 48" (measured from top of valve to top of extension). All extension kits can be cut shorter in the field for custom fits. Also available as Extension Components Kits, with or without valve for assembly with user-supplied Class 125 or Schedule 40 pipe. Kits without valve require use of existing valve top Access Plug, all kits require solvent cement assembly to valve. Contact Spears® for pricing on custom cut lengths.

**Sample Engineering Specification**

All thermoplastic valves shall be Backwater type constructed from PVC Type I, ASTM D 1784 Cell Classification 12454. All Valve Seats shall be EPDM. All valves shall have external Arrow Flow Indicator. All valves shall be pressure rated to 43 psi (100 feet of Head) for water @ 73°F as manufactured by Spears® Manufacturing Company.

**Quick-View Backwater Valve Selection Chart Standard Valve**

Valve Size	Seat Material	PVC Material	Pressure Rating
		Socket	
2	EPDM	S275P	43 psi (100 feet of Head)
3	EPDM	S375P	
4	EPDM	S475P	
6	EPDM	S675P	

**Quick View Extension Components Kit Options**

Extension Adapters and Flap Assembly with or without valve. Must be assembled with user-supplied Class 125 or Schedule 40 Pipe.

Valve Size	Socket Valve With Extension Component Kit	Extension Component Kit Only	Pressure Rating
2	S275P-AK	S275P-ECK	43 psi (100 feet of head)
3	S375P-AK	S375P-ECK	
4	S475P-AK	S475P-ECK	
6	S675P-AK	S675P-ECK	



**Quick View Backwater Valves with Extension Kit to Premade Lengths**

Socket Valve with complete Extension Assembly in precut lengths.

Valve x Extension Size <sup>1</sup>	Socket Valve With Extension	Valve x Extension Size <sup>1</sup>	Socket Valve With Extension	Pressure Rating
2 x 12HT	S275P-120	4 x 12HT	S475P-120	43 psi (100 feet of head)
2 x 16HT	S273P-160	4 x 16HT	S473P-160	
2 x 20HT	S275P-200	4 x 20HT	S475P-200	
2 x 24HT	S275P-240	4 x 24HT	S475P-240	
2 x 36HT	S275P-360	4 x 36HT	S475P-360	
2 x 48HT	S275P-480	4 x 48HT	S475P-480	
3 x 12HT	S375P-120	6 x 12HT	S675P-120	
3 x 16HT	S373P-160	6 x 16HT	S673P-160	
3 x 20HT	S375P-200	6 x 20HT	S675P-200	
3 x 24HT	S375P-240	6 x 24HT	S675P-240	
3 x 36HT	S375P-360	6 x 36HT	S675P-360	
3 x 48HT	S375P-480	6 x 48HT	S675P-480	

<sup>1</sup> - Size designates nominal valve size x extension height (HT-top of valve to top of extension, inches).

**Quick View Service Access Extension Kit Only In Premade Lengths** (valve not included)

Extension Assembly in precut lengths. Use existing valve top Access Plug.

Size <sup>1</sup>	Premade Extension	Size <sup>1</sup>	Premade Extension	Pressure Rating
2 x 12HT	SAEK-020-120	4 x 12HT	SAEK-040-120	43 psi (100 feet of head)
2 x 16HT	SAEK-020-160	4 x 16HT	SAEK-040-160	
2 x 20HT	SAEK-020-200	4 x 20HT	SAEK-040-200	
2 x 24HT	SAEK-020-240	4 x 24HT	SAEK-040-240	
2 x 36HT	SAEK-020-360	4 x 36HT	SAEK-040-360	
2 x 48HT	SAEK-020-480	4 x 48HT	SAEK-040-480	
3 x 12HT	SAEK-030-120	6 x 12HT	SAEK-060-120	
3 x 16HT	SAEK-030-160	6 x 16HT	SAEK-060-160	
3 x 20HT	SAEK-030-200	6 x 20HT	SAEK-060-200	
3 x 24HT	SAEK-030-240	6 x 24HT	SAEK-060-240	
3 x 36HT	SAEK-030-360	6 x 36HT	SAEK-060-360	
3 x 48HT	SAEK-030-480	6 x 48HT	SAEK-060-480	

<sup>1</sup> - Size designates nominal valve size x extension height (HT-top of valve to top of extension, inches). All extension kits can be cut shorter in the field for custom fits.

**STANDARD VALVE**

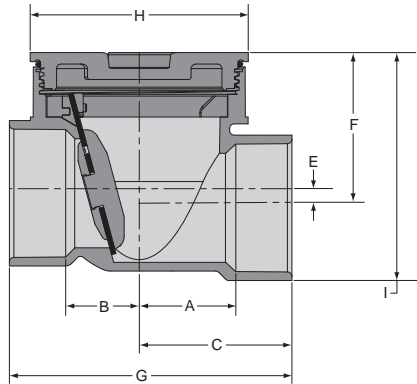

**Standard Valve Dimensions**

Size	A	B	C	E	F	G	H	I
2	1-13/16	1-3/4	2-5/8	5/16	3-1/4	5-9/32	4-3/16	4-9/16
3	2-5/8	2	4-3/16	13/32	4-1/8	7-3/4	6	6-1/8
4	3-5/8	3-3/4	5-7/16	23/32	5-7/16	10-15/16	8-1/4	7-15/16
6	4-3/4	4-5/8	7-3/4	13/16	7-3/16	15-3/8	11-1/4	10-13/16

**VALVE WITH EXTENSION KIT**

**Valve with Extension Kit Dimensions (Inches)**

HEIGHT-D
12
16
20
24
36
48
D = Top of plug Standard Valve to top of plug with Extension

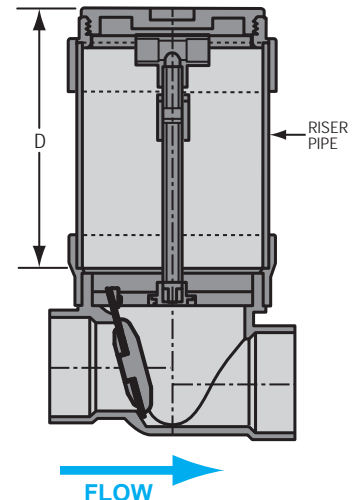



## Thermoplastic Valves Product Guide & Engineering Specifications

### True Union, Spigot, Flanged Diaphragm Valves



### Features – PVC, CPVC & PP

This full-featured valve is engineered to provide accurate throttling control and shutoff for industrial, chemical and water treatment applications. Weir-type design eliminates entrapped fluids in valve and is excellent for handling liquids with suspended solids, viscous fluids and slurries. Available in PVC, CPVC and Glass Filled Polypropylene with a variety of Diaphragm material options. PVC & CPVC 1/2" - 2" valves with Flanged Body, Spigot Body or True Union style Socket & Threaded ends or Optional Special Reinforced (SR) Threads, and sizes 2-1/2" - 8" with Flanged Body. Polypropylene 1/2" - 2" valves with True Union style Special Reinforced (SR) Threaded ends and sizes 2-1/2" - 8" with Flanged Body. True Union style also available in metric socket and BSP thread sizes 1/2" through 2".

- True Union Style with Buttress Thread Union Nuts - Mate with Spears® True Union 2000 Ball valves and Union 2000 Pipe Unions.
- EPDM, FKM, or Elastomer Backed (EPDM or FKM) PTFE Diaphragms.
- PVC & CPVC Sizes 1/2" - 2" Pressure Rated to 235 psi @ 73°F, Sizes 2-1/2" - 4" and all Flanged and all PTFE Diaphragm through 4" Pressure Rated to 150 psi @ 73°F, 6" Pressure Rated to 100 psi and 8" to 75 psi @ 73°F
- Polypropylene Sizes 1/2" - 4" Pressure rated to 150 psi @ 73°F
- Easy-Grip, High Impact Polypropylene Handwheel
- Built-in, Clear-View Position Indicator
- Stainless Steel External Hardware
- Fully Serviceable, Replaceable Components
- Suitable for Vacuum Service (except with PTFE Diaphragms)
- Assembled with Silicone-Free Lubricants (no lubricant in media contact area)

### Sample Engineering Specification

All thermoplastic Diaphragm valves shall be Weir-type constructed from PVC Type I, ASTM D 1784 Cell Classification 12454 or CPVC Type IV, ASTM D 1784 Cell Classification 23447, or Polypropylene, ASTM D 4101. All diaphragms shall be EPDM, FKM or PTFE with EPDM or FKM backing. All valves shall have built-in position indicator with polypropylene handwheel. All True Union style valve union nuts shall have Buttress threads. All PVC and CPVC 1/2" through 2" valves shall be pressure rated to 235 psi, all 2-1/2" through 4" and all flanged valves and valves with PTFE through 4" backing, shall be pressure rated to 150 psi, all 6" valves shall be pressure rated to 100 psi, and all 8" valves shall be pressure rated to 75 psi for water at 73°F. All Polypropylene valves shall be pressure rated to 150 psi for water at 73°F, as manufactured by Spears® Manufacturing Company.

### Special Options

- Hypalon® (CSM) Diaphragms
- Natural Polypropylene Body
- Electric or Pneumatic Actuation

Thermoplastic Valves Product Guide & Engineering Specifications  
**True Union, Spigot, Flanged Diaphragm Valves**



**PVC, CPVC & PP Diaphragm Valve Quick-View Selection Chart**

Size	O-ring Material	Diaphragm Material	PVC Part Number <sup>1</sup>				PP Part Number		Pressure Rating
			Soc/Thd	SR Threaded	Spigot	Flanged	SR Threaded	Flanged	
1/2	EPDM	EPDM	2729-005	2721-005SR	2727-005	2723-005	2721-005PSR	True Union & Spigot Style w/ Elastomer Diaphragms 235 psi Non-Shock Water @ 73°F	
		PTFE <sup>2</sup>	2729T-005	2721T-005SR	2797T-005	2793T-005	2721T-005PSR		
	FKM	FKM	2739-005	2731-005SR	2737-005	2733-005	2731-005PSR		
		PTFE <sup>2</sup>	2739VT-005	2731VT-005SR	2797VT-005	2793VT-005	2731VT-005PSR		
3/4	EPDM	EPDM	2729-007	2721-007SR	2727-007	2723-007	2721-007PSR		
		PTFE <sup>2</sup>	2729T-007	2721T-007SR	2797T-007	2793T-007	2721T-007PSR		
	FKM	FKM	2739-007	2731-007SR	2737-007	2733-007	2731-007PSR		
		PTFE <sup>2</sup>	2739VT-007	2731VT-007SR	2797VT-007	2793VT-007	2731VT-007PSR		
1	EPDM	EPDM	2729-010	2721-010SR	2727-010	2723-010	2721-010PSR		
		PTFE <sup>2</sup>	2729T-010	2721T-010SR	2797T-010	2793T-010	2721T-010PSR		
	FKM	FKM	2739-010	2731-010SR	2737-010	2733-010	2731-010PSR		
		PTFE <sup>2</sup>	2739VT-010	2731VT-010SR	2797VT-010	2793VT-010	2731VT-010PSR		
1-1/4	EPDM	EPDM	2729-012	2721-012SR	2727-012	2723-012	2721-012PSR		
		PTFE <sup>2</sup>	2729T-012	2721T-012SR	2797T-012	2793T-012	2721T-012PSR		
	FKM	FKM	2739-012	2731-012SR	2737-012	2733-012	2731-012PSR		
		PTFE <sup>2</sup>	2739VT-012	2731VT-012SR	2797VT-012	2793VT-012	2731VT-012PSR		
1-1/2	EPDM	EPDM	2729-015	2721-015SR	2727-015	2723-015	2721-015PSR		
		PTFE <sup>2</sup>	2729T-015	2721T-015SR	2797T-015	2793T-015	2721T-015PSR		
	FKM	FKM	2739-015	2731-015SR	2737-015	2733-015	2731-015PSR		
		PTFE <sup>2</sup>	2739VT-015	2731VT-015SR	2797VT-015	2793VT-015	2731VT-015PSR		
2	EPDM	EPDM	2729-020	2721-020SR	2727-020	2723-020	2721-020PSR		
		PTFE <sup>2</sup>	2729T-020	2721T-020SR	2797T-020	2793T-020	2721T-020PSR		
	FKM	FKM	2739-020	2731-020SR	2737-020	2733-020	2731-020PSR		
		PTFE <sup>2</sup>	2739VT-020	2731VT-020SR	2797VT-020	2793VT-020	2731VT-020PSR		
2-1/2	EPDM	EPDM				2723-025	2723-025P		
		PTFE <sup>2</sup>				2793T-025	2793T-025P		
	FKM	FKM				2733-025	2733-025P		
		PTFE <sup>2</sup>				2793VT-025	2793VT-025P		
3	EPDM	EPDM				2723-030	2723-030P		
		PTFE <sup>2</sup>				2793T-030	2793T-030P		
	FKM	FKM				2733-030	2733-030P		
		PTFE <sup>2</sup>				2793VT-030	2793VT-030P		
4	EPDM	EPDM				2723-040	2723-040P		
		PTFE <sup>2</sup>				2793T-040	2793T-040P		
	FKM	FKM				2733-040	2733-040P		
		PTFE <sup>2</sup>				2793VT-040	2793VT-040P		
6	EPDM	EPDM				2723-060	2723-060P		
		PTFE <sup>2</sup>				2793T-060	2793T-060P		
	FKM	FKM				2733-060	2733-060P		
		PTFE <sup>2</sup>				2793VT-060	2793VT-060P		
8	EPDM	EPDM				2723-080	2723-080P		
		PTFE <sup>2</sup>				2793T-080	2793T-080P		
	FKM	FKM				2733-080	2733-080P		
		PTFE <sup>2</sup>				2793VT-080	2793VT-080P		



1: For CPVC valves, add the letter "C" to part numbers listed (e.g., 2729-005C). Custom end connections available upon request.

2: Elastomer-backed PTFE (standard EPDM backed; special order FKM backed)



## Thermoplastic Valves Product Guide & Engineering Specifications

### True Union, Spigot, Flanged Diaphragm Valves

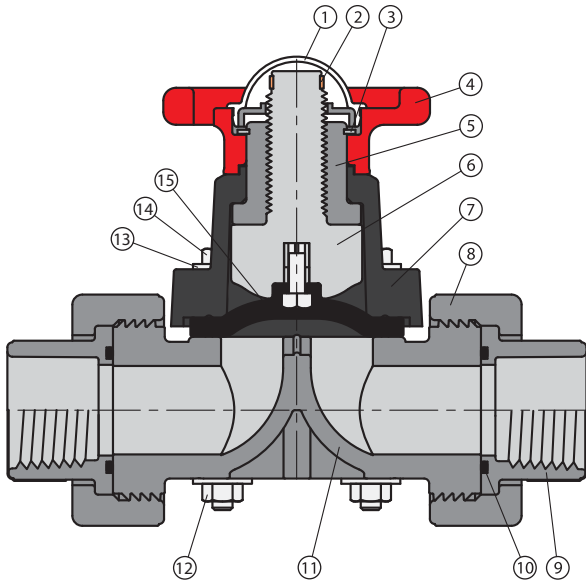

### Replacement Parts

No.	Component	Qty.	Material
1	Indicator Cover	1	PVC Clear
2	Indicator	1	PE
3	Retaining Ring	1	SS
4	Handwheel	1	PP
5	Compressor Bushing	1	PTFE/CPVC
6	Compressor	1	CPVC
7	Bonnet	1	GFPP
8	Union Nut	1	PVC/CPVC/GFPP
9	Union End	2	PVC/CPVC/GFPP
10	Union End O-ring	2	EPDM/FKM
11	Body	1	PVC/CPVC/GFPP
12	Nut	4-16	SS
13	Flat Washer	8-32	SS
14	Bolt	4-16	SS
15	Diaphragm	1	EPDM/FKM/PTFE

1: Component applicable to True Union style valves only.  
 2: True Union Socket/Threaded Valve illustrated

### Temperature Pressure Rating

System Operating Temperature °F (°C)		100 (38)	110 (43)	120 (49)	130 (54)	140 (60)	150 (66)	160 (71)	170 (77)	180 (82)	190 (88)	200 (93)	210 (99)	
Valve Pressure Rating psi (MPa)	1/2" - 2"	PVC	235 (1.62)	211 (1.45)	150 (1.03)	75 (.52)	50 (.34)	-0-	-0-	-0-	-0-	-0-	-0-	
		CPVC	235 (1.62)	219 (1.51)	170 (1.17)	145 (1.00)	130 (.90)	110 (.76)	90 (.62)	80 (.55)	70 (.48)	60 (.41)	50 (.34)	-0-
		PP	150 (1.03)	105 (.72)	90 (.62)	80 (.55)	75 (.52)	65 (.45)	55 (.38)	50 (.34)	45 (.31)	-0-	-0-	-0-
	2-1/2" - 4"	PVC	150 (1.03)	135 (.93)	110 (.76)	75 (.52)	50 (.34)	-0-	-0-	-0-	-0-	-0-	-0-	-0-
		CPVC	150 (1.03)	140 (.97)	130 (.90)	120 (.83)	110 (.76)	100 (.70)	90 (.62)	80 (.55)	70 (.48)	60 (.41)	50 (.34)	-0-
		PP	150 (1.03)	105 (.72)	90 (.62)	80 (.55)	75 (.52)	65 (.45)	55 (.38)	50 (.34)	45 (.31)	-0-	-0-	-0-
	6"	PVC	100 (.70)	90 (.62)	80 (.55)	65 (.38)	50 (.34)	-0-	-0-	-0-	-0-	-0-	-0-	-0-
		CPVC	100 (.70)	95 (.66)	90 (.62)	85 (.59)	80 (.55)	75 (.52)	70 (.48)	65 (.45)	60 (.41)	55 (.38)	50 (.34)	-0-
		PP	100 (.70)	90 (.62)	85 (.59)	75 (.52)	70 (.48)	60 (.41)	55 (.38)	50 (.34)	45 (.31)	-0-	-0-	-0-
	8"	PVC	75 (.52)	70 (.48)	65 (.45)	60 (.41)	50 (.34)	-0-	-0-	-0-	-0-	-0-	-0-	-0-
		CPVC	75 (.52)	72 (.49)	70 (.48)	67 (.46)	65 (.45)	62 (.43)	60 (.41)	55 (.38)	50 (.34)	45 (.31)	40 (.28)	-0-
		PP	75 (.52)	62 (.43)	60 (.41)	57 (.39)	55 (.38)	52 (.36)	50 (.34)	47 (.32)	45 (.31)	-0-	-0-	-0-



**C<sub>v</sub> Values PVC, CPVC & PP**

Valve Size	PERCENT OPEN			
	100%	75%	50%	25%
1/2	5.1	4.8	4.2	2.4
3/4	8.0	7.5	6.5	3.8
1	11.5	10.8	9.4	5.4
1-1/4	22.0	20.6	18.0	10.3
1-1/2	28.2	26.4	23.0	13.3
2	52.9	49.6	43.2	24.9
2-1/2	119.0	111.5	97.1	55.9
3	119.0	111.5	97.1	55.9
4	189.2	177.3	154.4	88.9
6	402.2	375.8	327.0	187.5
8	700.0	659.5	573.2	328.4

Gallons per minute at 1 psi pressure drop.

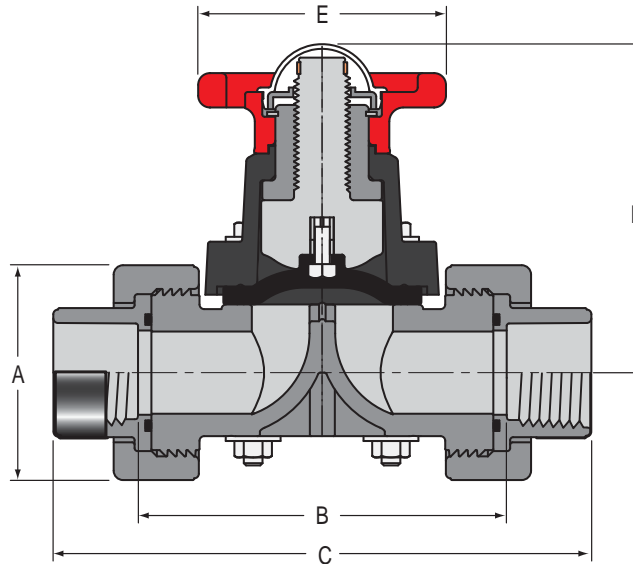

**Socket, Threaded & SR Threaded End Connectors Dimension & Weights**

Nominal Size	Dimension Reference (inches, ± 1/16)					Approx. Wt. (Lbs.)		
	A	B <sup>1</sup>	C		D	E	PVC	CPVC
			Socket	Threaded				
1/2	1-15/16	3-7/8	5-9/16	5-3/16	3-11/32	2-7/8	1.12	1.14
3/4	2-1/2	4-1/2	6-7/16	5-15/16	3-3/4	3-1/8	1.37	1.36
1	2-9/16	4-15/16	7-3/16	6-13/16	4-7/16	3-3/8	2.35	2.43
1-1/4	3-5/16	5-1/2	8-7/8	8-1/4	5-5/8	3-7/8	3.91	4.03
1-1/2	3-17/32	6-5/16	9-5/16	8-7/16	5-5/8	4-5/8	4.08	4.21
2	4-7/32	7-1/2	10-9/16	9-1/2	7	6-5/8	7.06	7.25

1: Valve Lay Length.



Thermoplastic Valves Product Guide & Engineering Specifications  
**True Union, Spigot, Flanged Diaphragm Valves**

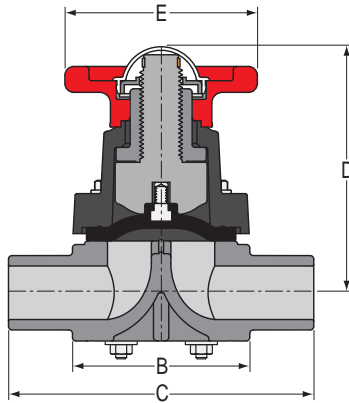

**Spigot Diaphragm Dimensions & Weights**

Nominal Size	Dimension Reference (inches, $\pm 1/16$ )				Approx. Wt. (Lbs.)	
	B	C	D	E	PVC	CPVC
1/2	2-5/8	4-7/8	3-11/32	2-7/8	.61	.63
3/4	2-3/4	5	3-3/4	3-1/4	.79	.82
1	3-1/8	5-3/8	4-7/16	3-5/16	1.32	1.36
1-1/4	3-3/4	6-1/4	5-5/8	4-19/32	2.41	2.50
1-1/2	3-3/4	6-1/2	5-5/8	4-19/32	2.43	2.52
2	4-3/4	7-3/4	7	5-7/8	4.15	4.43

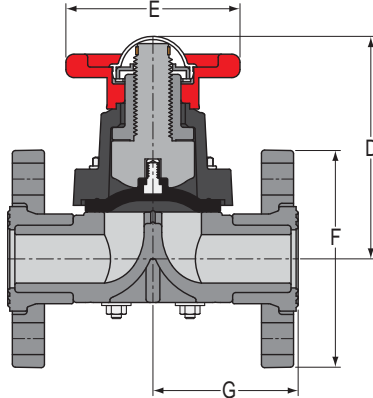

**Flanged Diaphragm Dimensions & Weights**

Nominal Size	Dimension Reference (inches, $\pm 1/16$ )				Approx. Wt. (Lbs.)	
	D	E	F	G	PVC	CPVC
1/2	3-11/32	2-7/8	3-1/2	2-9/16	.98	1.02
3/4	3-3/4	3-1/4	3-7/8	2-5/8	1.31	1.37
1	4-7/16	3-5/16	4-1/4	2-13/16	2.00	2.08
1-1/4	5-5/8	4-19/32	4-5/8	3-1/4	3.71	3.76
1-1/2	5-5/8	4-19/32	5	3-3/8	3.88	4.04
2	7	5-7/8	6	4	5.59	5.71
2-1/2	10-1/4	8-7/8	7-1/2	5-19/32	15.75	16.43
3	10-1/4	8-7/8	7-1/2	5-19/32	15.75	16.45
4	12-1/4	10-1/2	9	6-5/8	24.44	25.37
6	16-3/4	18-13/32	11	9-3/8	53.90	58.43
8	21	21-19/32	13-1/2	11-5/32	96.28	100.05



## Thermoplastic Valves Product Guide & Engineering Specifications

### Tee-Style "Zero Dead-leg" Diaphragm Valves



Tee x Spigot

### Features – PVC, Low Extractable PVC & CPVC

Spears® Tee-Style “Zero-Dead-Leg” Diaphragm Valve design integrates valve and Tee-fitting for direct branch take-off and eliminates the need for tees and reducing fittings normally required for service drops and other tie-ins to the loop. The Tee-Style valve provides a stronger, more compact connection enabling throttling, sampling, draining or diverting of critical process fluids. The “Zero Dead-leg” design is excellent for DI water and other critical applications. Close proximity of valve to mainline minimizes any areas of fluid stagnation by eliminating “dead leg” that can harbor bacterial growth and other contamination. Produced to order with Spigot, Socket & Threaded, or Special Reinforced (SR) Threaded end connection valve sizes 1/2" through 2", and specified Tee Socket connection sizes for virtually any mainline connection size.

### Sample Engineering Specification

All lateral branch valve connections shall be made using Tee-style Diaphragm Valves. All valves shall be constructed from PVC, ASTM D 1784 Cell Classification 12454; CPVC Type IV, ASTM D 1784 Cell Classification 23447; or Low Extractable PVC, ASTM D 1784 Cell Classification 12343. Diaphragms shall be EPDM, FKM or elastomer backed, bonded PTFE. All valves with elastomer diaphragms shall be pressure rated to 235 psi and all valves with PTFE diaphragms to 150 psi, for water at 73°F, as manufactured by Spears® Manufacturing Company.

### T-Style Valve Advantages

- Chemical & Corrosion Resistant PVC, CPVC or Low Extractable PVC materials
- Minimizes Fluid Stagnation
- Improves Branch Valve Connection Strength
- Simplifies Installation
- Suitable for Vacuum Service (except with PTFE Diaphragms)

### Diaphragm Valve Features

- Multi-featured Industrial Grade
- Built-in Position Indicator
- EPDM, FKM, or Elastomer Backed PTFE Diaphragm
- 235 psi Pressure Rating @ 73°F (150 psi for PTFE Diaphragms)
- High Impact Polypropylene Handle
- Fully Serviceable, Replaceable Components

### Quick-View Selection Chart

The following Base Part Numbers must be completed according to desired configuration size. Contact Spears® for the appropriate Tee size x Valve size code designations to replace the “xxx” in each.

Diaphragm Material	PVC Base Part Number			Pressure Rating @ 73°F (23°C)
	Spigot	Socket & Threaded	SR Threaded	
EPDM	2727ZD-xxx	2729ZD-xxx	2721ZD-xxxSR	1/2" – 2" 235 psi
FKM	2737ZD-xxx	2739ZD-xxx	2731ZD-xxxSR	
PTFE, EPDM Backing	2797TZD-xxx	2729TZD-xxx	2721TZD-xxxSR	1/2" – 2" 150 psi
PTFE/FKM Backing	2797VTZD-xxx	2739VTZD-xxx	2731VTZD-xxxSR	

Diaphragm Material	CPVC Base Part Number			Pressure Rating @ 73°F (23°C)
	Spigot	Socket & Threaded	SR Threaded	
EPDM	2727ZD-xxxC	2729ZD-xxxC	2721ZD-xxxCSR	1/2" – 2" 235 psi
FKM	2737ZD-xxxC	2739ZD-xxxC	2731ZD-xxxCSR	
PTFE, EPDM Backing	2797TZD-xxxC	2729TZD-xxxC	2721TZD-xxxCSR	1/2" – 2" 150 psi
PTFE/FKM Backing	2797VTZD-xxxC	2739VTZD-xxxC	2731VTZD-xxxCSR	

Diaphragm Material	Low Extractable PVC Base Part Number			Pressure Rating @ 73°F (23°C)
	Spigot	Socket & Threaded	SR Threaded	
EPDM	2727ZD-xxxBL	2729ZD-xxxBL	2721ZD-xxxSRBL	1/2" – 2" 235 psi
FKM	2737ZD-xxxBL	2739ZD-xxxBL	2731ZD-xxxSRBL	
PTFE, EPDM Backing	2797TZD-xxxBL	2729TZD-xxxBL	2721TZD-xxxSRBL	1/2" – 2" 150 psi
PTFE/FKM Backing	2797VTZD-xxxBL	2739VTZD-xxxBL	2731VTZD-xxxSRBL	

**Note:** Low Extractable PVC Valves are typically used with elastomer backed PTFE Diaphragms to maintain purity in most applications.





## Thermoplastic Valves Product Guide & Engineering Specifications

### Tee-Style "Zero Dead-leg" Diaphragm Valves

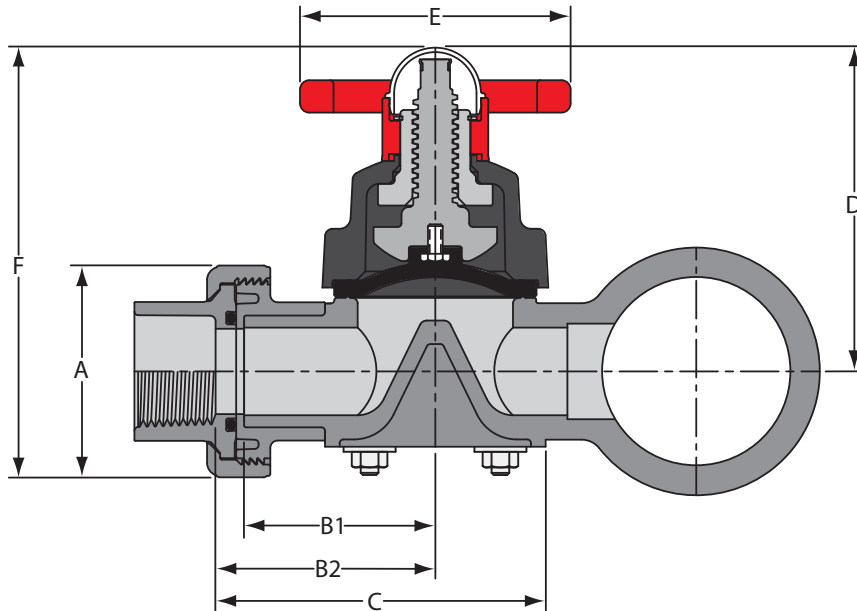

### Dimensions

Nominal Size	Dimension Reference ( $\pm 1/16$ )						
	A	Spigot B1	Socket Threaded B2	C	D	E	F
1/2	1-15/16	2-3/16	2-1/2	3-13/16	3-5/16	2-7/8	4-5/16
3/4	2-3/8	2-3/8	2-3/4	4-1/8	3-3/4	3-1/4	4-9/16
1	2-5/8	2-11/16	3-1/16	4-5/8	4-7/16	3-5/16	5-3/4
1-1/4	3-3/16	3-1/8	3-1/2	5-3/8	5-5/8	4-5/8	7-1/4
1-1/2	3-9/16	3-1/4	3-3/4	5-5/8	5-5/8	4-5/8	7-7/16
2	4-5/16	4-7/8	4-3/8	6-3/4	7	5-7/8	9-3/16

### Temperature Pressure Rating

Nominal Valve Size	73°F to 100°F	110°F	120°F	130°F	140°F
1/2" - 2"	150	135	110	75	50

Valves have elevated temperature pressure ratings different than pipe, as shown in chart above. Maximum PVC system service temperature is 140°F.

### Cv Values

Valve Size	PERCENT OPEN			
	100%	75%	50%	25%
1/2	5.1	4.8	4.2	2.4
3/4	8.0	7.5	6.5	6.5
1	11.5	10.8	9.4	9.4
1-1/4	22.0	20.6	18.0	18.0
1-1/2	28.2	26.4	23.0	23.0
2	52.9	49.6	43.2	43.2

**Note:** Cv values are for basic Diaphragm Valve only, excluding Tee end connection.



Ease of installation and maintenance is one of the major advantages of using thermoplastic valves. As with any product, certain procedures must be followed for successful installation, service and long life. This section specifies individual installation and maintenance service instructions for Spears® valves. All applicable instructions and procedures should be read thoroughly before starting. Suitability of the intended service application should be determined prior to installation. Please review **“Material Considerations in Application and System Design”**, in the **“MATERIALS”** section of this manual for important additional considerations related valve installations.

Plastic piping systems should be engineered, installed, operated and maintained in accordance with accepted standards and procedures for plastic piping systems. It is absolutely necessary that all design, installation, operation and maintenance personnel be trained in proper handling, installation requirements and precautions for installation and use of plastic piping systems before starting.

Individual valve installation instructions specific to each product type are packaged with product. The following sections of this manual contain safety precautions and procedures for making solvent cement, threaded or flanged joints.

## Precautions & Warnings for All Valve, Strainer & Accessories Installations

**CAUTION:** *The system shall be designed and installed so as not to pull the valve in any direction. Valve and strainers must be supported with conventional piping system support devices.*

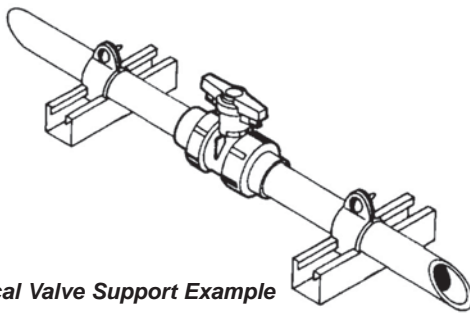

Typical Valve Support Example

**CAUTION:** All valve connectors and connecting pipe should be inspected for any breaking, chipping, gouging or other visible damage before proceeding. All joining components must be clean and dry. All valves and pipe shall be removed from their packaging or containers and exposed to the environment for a minimum of one hour in order to thermally balance all components. Installation temperatures should be between 40°F and 110°F.

**CAUTION:** All valves with fixed socket end connectors in the body must be installed in the open position to aid in evaporation of solvent vapors which can attack internal components. **WARNING: TAKE EXTRA CARE THAT NO PRIMER OR SOLVENT CEMENT IS ALLOWED TO COME IN CONTACT WITH THE BALL OR OTHER INTERNAL VALVE COMPONENTS.**

**CAUTION:** Threaded pipe connections require application of a quality grade thread sealant to seal joint assembly. Sealant should be applied to male pipe threads. **WARNING: SOME PIPE JOINT COMPOUNDS OR PTFE PASTES MAY CONTAIN SUBSTANCES THAT COULD CAUSE STRESS CRACKING IN THERMOPLASTIC MATERIALS.**

Spears® Manufacturing Company recommends the use of Spears® **BLUE 75™** thread sealant which has been tested for compatibility with Spears® products. Please follow the sealant manufacturers' application/installation instructions. Choice of an appropriate thread sealant other than those listed above is at the discretion of the installer.

**CAUTION: BEFORE THE VALVE IS CYCLED**, all dirt, sand, grit or other material shall be flushed from the system. This is to prevent scarring of internal components; e.g., ball, cup, wedge, seats, etc.

**WARNING: Some Lubricants, including vegetable oils, are known to cause stress cracking in thermoplastic materials.** All lubricants should be checked for compatibility with PVC, CPVC or other thermoplastic products. Formulation changes by lubricant manufacturers may alter compatibility of previously acceptable materials and are beyond our control. Choice of lubricant is at the discretion of the installer.

**WARNING: DO NOT USE COMPRESSED AIR OR GAS TO TEST ANY PVC OR CPVC THERMOPLASTIC PIPING PRODUCT OR SYSTEM, AND DO NOT USE DEVICES PROPELLED BY COMPRESSED AIR OR GAS TO CLEAR SYSTEMS. THESE PRACTICES MAY RESULT IN EXPLOSIVE FRAGMENTATION OF SYSTEM PIPING AND COMPONENTS CAUSING SERIOUS OR FATAL BODILY INJURY.** All air must be bled from the system during initial fluid fill. Pressure testing of the system should not be made until all solvent cement joints have properly cured. Initial pressure testing should be made at approximately 10% of the system hydrostatic pressure rating to identify potential problems, prior to testing at higher pressures.

**WARNING:** Systems should not be operated or flushed out at flow velocities greater than 5 feet per second.





## Thermoplastic Valves Product Guide & Engineering Specifications

### Solvent Cement Welded Joints

Spears® Manufacturing Company recommends following solvent cement manufacturer's recommendations and reading ASTM D 2855, "Standard Practice for Making Solvent-Cemented Joints with Poly Vinyl Chloride (PVC) Pipe and Fittings". This method of joining valves and piping system components is very simple and reliable if procedures are followed correctly. Since variables of temperature, humidity, pipe size, time, and other conditions have a significant effect on solvent cement joints, it is important to understand the principles of each step and make adjustments for actual conditions. Shortcuts or excessive deviations may result in joint failures and / or frozen valve movements.

### Safety Precautions

**WARNING:** Solvent cements and primers for pipe, fittings and valves are flammable. Extinguish all smoking materials, flames, or other ignition sources in working or storage areas. Be sure to work only in a well-ventilated space. Avoid eye and unnecessary skin contact with all cements, primers or solvents. Ingestion or intentional inhalation of solvent vapors can be harmful or fatal. Additional safety precautions may apply, consult solvent cement manufacturer.

### Selection of Solvent Cement

A wide variety of solvent cements and primers are commercially available. Selection of specific type, grade and consistency of solvent cement should take into account pipe type, size, installation conditions and chemical compatibility of cement and system fluids. Contact solvent cement manufacturer for additional information.

### Required Materials

- Saw & miter box or wheel-type cutter
- Pipe deburring & beveling tool or mill file
- Solvent Cement — PVC cement for PVC materials, CPVC cement for CPVC materials; heavy bodied, as manufactured by Spears® Manufacturing Company
- Primer — as manufactured by Spears® Manufacturing Company
- Brush or dauber type cement and primer applicators — select a size no less than 1/2 the pipe diameter (see chart below).
- Use containers — sealable metal or glass to hold cements and primers
- Cotton cleaning rags
- Cleanup solvents — such as tetrahydrofuran (THF) or methylethylketone (MEK)

### Recommended Applicator Size for Solvent Cement and Primer

Applicator Type & Size (in.)	Nominal Pipe Size (in.)									
	1/2	3/4	1	1-1/4	1-1/2	2	2-1/2	3	4	5
Brush*	1/2		1			1-1/2		2	3	5
Dauber	3/4		1-1/2			Not Recommended				
Roller	Not Recommended								3	

### General Procedure Outline

#### General Preparation

For best results, installation should be made at temperatures between 40°F and 110°F.

All joint components should be inspected for any breaking, chipping, gouging or other visible damage before proceeding. All pipe and fittings should be removed from their packaging or containers and exposed to the installation environment for a minimum of one hour in order to thermally balance all components.

On True Union Ball, Check and Diaphragm valves, remove union nuts and end connectors before priming and cementing connections. With the threads facing the valve, slide the union nut over the pipe to which the end connector socket is to be cemented. Reinstall the valve body and union nuts only after the joint has fully cured.

On valves with fixed socket connections in the body, be sure the valve is in the open position to aid in evaporation of solvent vapors which can attack internal components. **TAKE EXTRA CARE THAT NO PRIMER OR SOLVENT CEMENT IS ALLOWED TO COME IN CONTACT WITH THE BALL OR OTHER INTERNAL VALVE COMPONENTS.**

#### Step 1: Cut Pipe Square

Pipe ends must be cut square, using a wheel-type cutter or saw & miter box. A fine-toothed hand saw (16-18 teeth / inch) with little or no set is recommended. A power cutoff saw with carbide blade is recommended for high volume cutting.

#### Step 2: Deburr & Bevel Pipe

Regardless of cutting method used in step 1, burrs are created which must be removed from both the pipe I.D. and O.D. before joining. All pipe ends should be beveled 10° to 15°. Commercially available deburring & beveling tool is recommended, or a mill file may be used.

#### Step 3: Clean Joint Components

Wipe away all loose dirt and moisture from the pipe O.D. and fitting I.D. with a clean, dry cotton rag. **DO NOT ATTEMPT TO JOIN WET SURFACES.**

#### Step 4: Check Joint Interference Fit

An interference between pipe and fitting socket is necessary for proper fusion of the joint. To check, lightly insert pipe into fitting socket. **DO NOT FORCE.** Interference between pipe and fitting should occur between 1/3 to 2/3 of the socket depth (full interference fit) and the socket bottom (net fit). Do not use components which improperly mate.



**Step 5: Apply Primer**

Primer is necessary to penetrate and soften both pipe and fitting socket surfaces in order for the solvent cement to properly bond. **THE MOST FREQUENT CAUSE OF JOINT FAILURES IS INADEQUATE SOLVENT PENETRATION AND SOFTENING OF BONDING SURFACES DURING THE WELDING OPERATION.**

1. Using a brush or applicator size no less than 1/2 the pipe diameter, apply a liberal coat of primer with a scrubbing motion to the fitting socket until the surface is softened and semi-fluid. This may take 5 to 15 seconds depending on size and temperature (larger diameters and lower temperatures will increase required time).
2. Apply primer to pipe in the same manner, extending application area to slightly more than the insertion depth into the fitting socket.
3. Apply a second coat to both the fitting socket and the pipe.
4. Check penetration and softening by scraping the primed surfaces. A few thousandths of the semi-fluid surface should be easily removed. Repeat primer application if necessary.

**Step 6: Apply Solvent Cement**

Solvent cement must be applied **IMMEDIATELY** to primed surfaces before the primer dries in an alternating 3-coat application. Using a brush or applicator size no less than 1/2 the pipe diameter, apply a liberal coat of solvent cement to the primed pipe surface, then apply a light to medium coat to the primed fitting socket. If a “net fit” was experienced during dry fit check (Step 4), apply an additional coat again to the pipe surface. **BE SURE TO USE A VERY LIBERAL AMOUNT OF SOLVENT CEMENT ON PIPE.**

**VALVE INSTALLATION CAUTION:** TAKE EXTRA CARE THAT NO PRIMER OR SOLVENT CEMENT IS ALLOWED TO CONTACT THE BALL OR OTHER INTERNAL VALVE COMPONENTS.

**Step 7: Join Components**

**IMMEDIATELY** following application of cement and before it starts to set, insert the pipe into the fitting socket with a one-quarter turn, twisting motion to evenly distribute cement within the joint. A full bead of cement should form around the circumference of the joint. Hold joint together for approximately 30 seconds to make sure the pipe does not move or back out of the socket.

**CAUTION:** ABSENCE OF BEAD FORMATION, VOIDS, OR GAPS IN THE BEAD ARE A SIGN OF INSUFFICIENT CEMENT APPLICATION. IF SUCH IS OBSERVED, IMMEDIATELY PULL THE JOINT APART AND REAPPLY AN ADEQUATE AMOUNT OF CEMENT.

**Step 8: Remove Excess Cement**

Using a cloth, wipe clean all excess cement from the exterior juncture of the pipe and fitting.

**Step 9: Initial Set Time**

The joint must not be handled or moved for a minimum of 2 minutes, after which the joint must be handled carefully until the cement has gone through a set period. Recommended minimum set time:

- 30 minutes minimum at 60° to 100°F (15° to 40°C)
- 1 hour minimum at 40° to 60°F (5° to 15°C)
- 2 hours minimum at 20° to 40°F (-5° to 5°C)
- 4 hours minimum at 0° to 20°F (-20° to -5°C)

**Step 10: Joint Cure Time**

The joint must adequately cure prior to use (see “Joint Cure Schedule” table below). Required cure time depends on temperature, pipe diameter, and pressure application. The following table is based on the guidelines of ASTM D 2855, “Standard Practice for Making Solvent-Cemented Joints with Poly Vinyl Chloride (PVC) Pipe and Fittings”. It is the user’s responsibility and risk in determining that the joint has properly cured for handling, testing, and use.



**Joint Cure Schedule**

Temperature	60° - 100°F		40° - 60°F		20° - 40°F		10° - 20°F	
	Test Pressure (psi)		Test Pressure (psi)		Test Pressure (psi)		Test Pressure (psi)	
Nominal Pipe Size (in.)	0-180	181-315	0-180	181-315	0-180	181-315	0-180	181-315
1/2 to 1-1/4	1 hour	6 hours	2 hours	12 hours	6 hours	36 hours	8 hours	48 hours
1-1/2 to 3	2 hours	12 hours	4 hours	24 hours	12 hours	72 hours	16 hours	96 hours
3-1/2 to 5	6 hours	18 hours	12 hours	36 hours	36 hours	4 days	72 hours	8 days
6 to 8	8 hours	24 hours	16 hours	48 hours	3 days	9 days	4 days	12 days

**NOTE:** Extreme caution should be used when solvent cementing joints at temperatures below 10°F, and many variables exist at temperatures below 20°F. Relative humidity greater than 50% will increase required cure times specified. Consult solvent cement manufacturer for additional information.



## Thermoplastic Valves Product Guide & Engineering Specifications

### Threaded Connections

Threaded joints are used where piping system dismantling for occasional cleaning or modification is anticipated. Since threading reduces the effective wall thickness of pipe, pressure ratings of the pipe are reduced to one-half that of unthreaded pipe using solvent cement welded joints. Valves, however, have individual pressure ratings substantially different from that of pipe. As a result, no reduction in the valve's specified pressure rating is necessary for threaded connections. Threaded systems should be made with Schedule 80 pipe only, threaded with an ANSI general purpose tapered pipe thread (NPT). Schedule 40 pipe should not be threaded.

## General Procedure Outline

### Step 1: Apply Joint Sealant

Threaded connections require application of a quality grade thread sealant to seal joint assembly.

**WARNING: SOME PIPE JOINT COMPOUNDS OR PTFE PASTES MAY CONTAIN SUBSTANCES THAT COULD CAUSE STRESS CRACKING IN THERMOPLASTIC MATERIALS.** Spears® Manufacturing Company recommends the use of Spears® **BLUE 75™** thread sealant which has been tested for compatibility with Spears® products. Please follow the sealant manufacturers' application / installation instructions. Choice of an appropriate thread sealant other than those listed above is at the discretion of the installer.

### Step 2: Assemble Joint by Hand

Threaded pipe and valves or fittings should be initially assembled "finger tight" (just enough to fully engage thread clearance).

### Step 3: Strap Wrench Make-Up

Threaded plastic pipe and fitting components should always be installed using commercially available strap wrenches. Do not use conventional pipe wrenches which can damage plastic piping materials.

**WARNING: THE SINGLE MOST COMMON CAUSE OF THREADED JOINT FAILURE IS OVER TIGHTENING.** Tapered pipe threads produce radial stress in female fittings. Over tightening can exceed the stress limits of thermoplastic materials, resulting in split fittings.

Apply strap wrench make-up of **no more than one to two turns** beyond finger tight thread engagement. Care should be taken in final positioning so as to avoid the need to "back-up" the wrenched assembly.

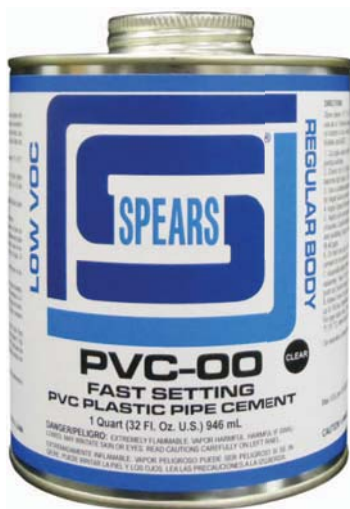



Flanges are used extensively for connections where removable system components are desired. Such includes periodic system servicing, anticipated system modification or add-on, and temporary component hookups. Flanges are also the standard connection for industrial butterfly type valves.

### Pressure Ratings

Plastic pipe flanges are designed for system maximum internal pressures of 150 psi, water at 73°F, which must be taken into consideration when using flanges with higher pressure rated components, such as pipe or valves. As with all thermoplastic piping materials, pressure rating is a function of temperature. Refer to **“Temperature Pressure Rating for 150 psi Flanges”** chart below and that specified for individual products. Certain variations may exist according to product type and size.

### Bolt Holes & Pattern

Bolt patterns and number of bolt holes are the same as Class 150 metal flanges per ANSI B16.5.

### Gaskets

Full faced, 1/8" thick elastomer gaskets with a Shore “A” Durometer of approximately 70 is recommended.

### Bolt Torque

Recommended Bolt torque requirements are shown below. Threads should be clean and well lubricated. Actual field conditions may require variations in these recommendations.

**CAUTION: UNNECESSARY OVER TORQUING WILL DAMAGE THE FLANGE.**

Flange Size (in.)	Recommended Torque (ft. lbs.)
1/2 - 1-1/2	12
2 - 4	25
5	30
6 - 8	40
10	64
12	95
14 - 24	110

### Torque Sequence

Bolts should be tightened in a 180° opposing pattern. Recommended bolt torque sequence is shown in the following table.

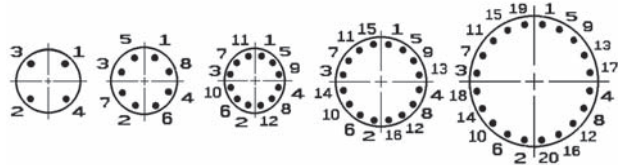

### General Procedure Outline

Once a flange is attached to the pipe or valve, the method of joining two flanges is as follows:

- Step 1:** Piping runs joined to the flanges must be installed in a straight line position to the flange to avoid stress at the flange due to misalignment. Piping must also be secured and supported to prevent lateral movement which can create stress and damage the flange.
- Step 2:** With gasket in place, align the bolt holes of the mating flanges by rotating the ring into position (Consideration should be given to alignment of One Piece Flange prior to joining with pipe.)
- Step 3:** Insert all bolts, washers (two standard flat washers per bolt), and nuts.
- Step 4:** Make sure the faces of the mating surfaces are flush against gasket prior to bolting down the flanges.
- Step 5:** Tighten the nuts by hand until they are snug. Establish uniform pressure over the flange face by tightening the bolts in 5 ft.-lbs. increments according to the sequence shown in the above table following a 180° opposing sequence.
- Step 6:** Care must be taken to avoid “bending” the flange when joining a Spears® flange to a “raised face flange, or a wafer-style valve. Do not use bolts to bring together improperly mated flanges.



### Temperature Pressure Rating

System Operating Temperature °F (°C)	100 (38)	110 (43)	120 (49)	130 (54)	140 (60)	150 (66)	160 (71)	170 (77)	180 (82)	190 (88)	200 (93)	210 (99)
Flange Pressure Rating psi (MPa)	PVC	150 (1.03)	135 (.93)	110 (.76)	75 (.52)	50 (.34)	-0- (-0-)	-0- (-0-)	-0- (-0-)	-0- (-0-)	-0- (-0-)	-0- (-0-)
	CPVC	150 (1.03)	140 (.97)	130 (.90)	120 (.83)	110 (.76)	100 (.70)	90 (.62)	80 (.55)	70 (.48)	60 (.41)	50 (.34)
	PP	150 (1.03)	105 (.72)	90 (.62)	80 (.55)	65 (.45)	50 (.34)	45 (.31)	30 (.21)	20 (.14)	-0- (-0-)	-0- (-0-)



## Thermoplastic Valves Product Guide & Engineering Specifications

### Valve Service & Replacement Kits

For easy servicing and extended valve life, Spears® provides numerous maintenance repair kits and replaceable components for all repairable valves. Repair Kits generally include applicable seats, O-ring seals, diaphragms and other components typically subjected to normal operational wear.

Full Cartridge Replacement Kits are available for all True Union style ball valves and ball check valves. These include complete valve assembly, less union nuts and end connectors. Replacement Cartridges can be directly installed in place of existing valve unit using existing union nuts and end connectors.

Individual valve replacement parts may be ordered from the factory. Complete maintenance service instructions for each valve are available. Please contact Spears® Technical Services Department.

### True Union 2000 Industrial Ball Valve Seat & O-ring Repair Kit

All kits include PTFE Seats (2), End Connector O-rings (2), Seal Carrier O-ring (1), Stem Bushing (1) and Stem O-rings (2). Sizes 2-1/2" & larger includes Seat O-rings (2).

Size	Part Number	
	w/EPDM O-rings	w/FKM O-rings
1/2	TU2-ERK-005	TU2-VRK-005
3/4	TU2-ERK-007	TU2-VRK-007
1	TU2-ERK-010	TU2-VRK-010
1-1/4	TU2-ERK-012	TU2-VRK-012
1-1/2	TU2-ERK-015	TU2-VRK-015
2	TU2-ERK-020	TU2-VRK-020
2-1/2 & 3	TU2-ERK-030	TU2-VRK-030
4	TU2-ERK-040	TU2-VRK-040
6	TU2-ERK-060	TU2-VRK-060

### True Union 2000 Industrial Ball Valve Cartridge Replacement Kit

Includes valve assembly, less union nuts and end connectors.

Size	PVC Part Number <sup>1</sup>	
	w/EPDM O-rings	w/FKM O-rings
1/2	1820-005	1830-005
3/4	1820-007	1830-007
1	1820-010	1830-010
1-1/4	1820-012	1830-012
1-1/2	1820-015	1830-015
2	1820-020	1830-020
2-1/2 & 3	1820-030	1830-030
4	1820-040	1830-040
6	1820-060	1830-060

1: For CPVC Cartridge Kit, add the letter "C" to the part numbers listed (e.g. 1820-005C).

### True Union 2000 Standard Ball Valve Seat & O-ring Repair Kit

All kits include PTFE/HDPE Seats (2), End Connector O-rings (2), Seal Carrier O-ring (1), and Stem O-rings (2).

Size	Part Number	
	w/EPDM O-rings	w/FKM O-rings
1/2	TU1-ERK-005	TU1-VRK-005
3/4	TU1-ERK-007	TU1-VRK-007
1	TU1-ERK-010	TU1-VRK-010
1-1/4	TU1-ERK-012	TU1-VRK-012
1-1/2	TU1-ERK-015	TU1-VRK-015
2	TU1-ERK-020	TU1-VRK-020
2-1/2 & 3	TU1-ERK-030	TU1-VRK-030
4	TU1-ERK-040	TU1-VRK-040

### True Union 2000 Standard Ball Valve Cartridge Replacement Kit

Includes valve assembly, less union nuts and end connectors.

Size	PVC Part Number <sup>1</sup>	
	w/EPDM O-rings	w/FKM O-rings
1/2	3620-005	3630-005
3/4	3620-007	3630-007
1	3620-010	3630-010
1-1/4	3620-012	3630-012
1-1/2	3620-015	3630-015
2	3620-020	3630-020
2-1/2 & 3	3620-030	3630-030
4	3620-040	3630-040

1: For CPVC Cartridge Kit, add the letter "C" to the part numbers listed (e.g. 3620-005C).



### True Union 2000 Industrial 3-Way Ball Valve

#### Seat & O-ring Repair Kit (Horizontal or Vertical)

All kits include PTFE Seats (2-no branch seal), End Connector O-rings (3), Seal Carrier O-ring (1), Stem Bushing (1) and Stem O-rings (2). Sizes 2-1/2" & larger includes Seat O-rings (2).

Size	Part Number	
	w/EPDM O-rings	w/FKM O-rings
1/2	TU3-ERK-005	TU3-VRK-005
3/4	TU3-ERK-007	TU3-VRK-007
1	TU3-ERK-010	TU3-VRK-010
1-1/4	TU3-ERK-012	TU3-VRK-012
1-1/2	TU3-ERK-015	TU3-VRK-015
2	TU3-ERK-020	TU3-VRK-020
2-1/2 & 3	TU3-ERK-030	TU3-VRK-030
4	TU3-ERK-040	TU3-VRK-040

### True Union 2000 Industrial Ball Check Valve

#### O-ring Repair Kit

All kits include End Connector O-rings (2), Seal Carrier O-ring (1), Seat Plate O-ring (1).

Size	Part Number	
	w/EPDM O-rings	w/FKM O-rings
1/2	CK2-ERK-005	CK2-VRK-005
3/4	CK2-ERK-007	CK2-VRK-007
1	CK2-ERK-010	CK2-VRK-010
1-1/4	CK2-ERK-012	CK2-VRK-012
1-1/2	CK2-ERK-015	CK2-VRK-015
2	CK2-ERK-020	CK2-VRK-020
2-1/2 & 3	CK2-ERK-030	CK2-VRK-030
4	CK2-ERK-040	CK2-VRK-040
6	CK2-ERK-060	CK2-VRK-060

### Regular True Union Ball Valve Seat & O-ring Repair Kit

All kits include End Connector O-rings (2), Seal Carrier O-ring (1), Stem Bushing (1) and Seat O-ring (1).

Size	Part Number	
	w/EPDM O-rings	w/FKM O-rings
1/2	TU-ERK-005	TU-VRK-005
3/4	TU-ERK-007	TU-VRK-007
1	TU-ERK-010	TU-VRK-010
1-1/4	TU-ERK-012	TU-VRK-012
1-1/2	TU-ERK-015	TU-VRK-015
2	TU-ERK-020	TU-VRK-020
2-1/2 & 3	TU-ERK-030	TU-VRK-030
4 & 6	TU-ERK-040	TU-VRK-040

### True Union 2000 Industrial 3-Way Ball Valve

#### Cartridge Replacement Kit

Includes valve assembly, less union nuts and end connectors.

Size	Vertical PVC Part Number <sup>1,2,5</sup>		Horizontal PVC Part Number <sup>1,2,3,4</sup>	
	w/EPDM O-rings	w/FKM O-rings	w/EPDM O-rings	w/FKM O-rings
1/2	4720L1-005	4730L1-005	5020L1-005	5030L1-005
3/4	4720L1-007	4730L1-007	5020L1-007	5030L1-007
1	4720L1-010	4730L1-010	5020L1-010	5030L1-010
1-1/4	4720L1-012	4730L1-012	5020L1-012	5030L1-012
1-1/2	4720L1-015	4730L1-015	5020L1-015	5030L1-015
2	4720L1-020	4730L1-020	5020L1-020	5030L1-020
2-1/2 & 3	4720L1-030	4730L1-030	5020L1-030	5030L1-030
4	4720L1-040	4730L1-040	5020L1-040	5030L1-040

1: For CPVC Cartridge Kit, add the letter "C" to the part numbers listed (e.g. 4720L1-005C).

2: For Double L-Port, change "L1" portion of part number to L2 (e.g. 4720L2-005).

3: For Tripple L-Port, change "L1" portion of part number to L3 (e.g. 4720L3-005).

4: For T-Port, change "L1" portion of part number to "T" (e.g. 4720T-005).

### True Union 2000 Industrial Ball Check Valve

#### Cartridge Replacement Kit

Includes valve assembly, less union nuts and end connectors.

Size	PVC Part Number <sup>1</sup>	
	w/EPDM O-rings	w/FKM O-rings
1/2	4520-005	4530-005
3/4	4520-007	4530-007
1	4520-010	4530-010
1-1/4	4520-012	4530-012
1-1/2	4520-015	4530-015
2	4520-020	4530-020
2-1/2 & 3	4520-030	4530-030
4	4520-040	4530-040
6	4520-060	4530-060

1: For CPVC Cartridge Kit, add the letter "C" to the part numbers listed (e.g. 4520-005C).



### Regular True Union Ball Check Valve O-ring Repair Kit

Includes ball seal O-ring (1), end-connector O-rings (2), and seal carrier O-ring (1).

Size	Part Number	
	w/EPDM O-rings	w/FKM O-rings
1/2	CK-ERK-005	CK-VRK-005
3/4	CK-ERK-007	CK-VRK-007
1	CK-ERK-010	CK-VRK-010
1-1/4	CK-ERK-012	CK-VRK-012
1-1/2	CK-ERK-015	CK-VRK-015
2	CK-ERK-020	CK-VRK-020
2-1/2 & 3	CK-ERK-030	CK-VRK-030
4	CK-ERK-040	CK-VRK-040



**Thermoplastic Valves Product Guide & Engineering Specifications**  
**Valve Service & Replacement Kits**

**Regular True Union Ball Valve  
Cartridge Replacement Kit**

Includes valve assembly, less union nuts, and end connectors.

Size	PVC Part Number <sup>1</sup>	
	w/EPDM O-rings	w/FKM O-rings
1/2	2320-005	2330-005
3/4	2320-007	2330-007
1	2320-010	2330-010
1-1/4	2320-012	2330-012
1-1/2	2320-015	2330-015
2	2320-020	2330-020
2-1/2 & 3	2320-030	2330-030
4 & 6	2320-040	2330-040

<sup>1</sup> For CPVC Cartridge Kit, add the letter "C" to part numbers listed (e.g., 2320-005C).

**Regular True Union Ball Check Valve  
Cartridge Replacement Kit**

Includes valve assembly, less union nuts, and end connectors.

Size	PVC Part Number <sup>1</sup>	
	w/EPDM O-rings	w/FKM O-rings
1/2	2220-005	2230-005
3/4	2220-007	2230-007
1	2220-010	2230-010
1-1/4	2220-012	2230-012
1-1/2	2220-015	2230-015
2	2220-020	2230-020
2-1/2 & 3	2220-030	2230-030
4	2220-040	2230-040

<sup>1</sup> For CPVC Cartridge Kit, add the letter "C" to part numbers listed (e.g., 2220-005C).

**Single Entry Ball Valve  
Seat & O-ring Replacement Kit**

Includes PTFE seats (2), seat O-rings (2), and seal carrier O-ring (1).

Size	Part Number		
	w/Buna-N O-rings	w/EPDM O-rings	w/FKM O-rings
1/2	SE-BRK-005	SE-ERK-005	SE-VRK-005
3/4	SE-BRK-007	SE-ERK-007	SE-VRK-007
1	SE-BRK-010	SE-ERK-010	SE-VRK-010
1-1/4 & 1-1/2	SE-BRK-015	SE-ERK-015	SE-VRK-015
2	SE-BRK-020	SE-ERK-020	SE-VRK-020
3	SE-BRK-030	SE-ERK-030	SE-VRK-030
4	SE-BRK-040	SE-ERK-040	SE-VRK-040

**Gate Valve  
O-ring Repair Kit**

1/2" through 2" Kit includes stem O-ring (1), body O-ring (1), wedge O-ring or gasket (1), stem bushing (1) and stem washer (1).

2" and 3" Kit includes seal carrier O-ring (1), stem O-ring (1), stem washer (1) and stem bushing (1).

4" Kit includes carrier O-ring (1), stem O-ring (1) and stem bushing.

Size	Part Number		
	w/Buna-N O-rings	w/EPDM O-rings	w/FKM O-rings
1/2	GT-BRK-005	GT-ERK-005	GT-VRK-005
3/4	GT-BRK-007	GT-ERK-007	GT-VRK-007
1	GT-BRK-010	GT-ERK-010	GT-VRK-010
1-1/4	GT-BRK-012	GT-ERK-012	GT-VRK-012
1-1/2	GT-BRK-015	GT-ERK-015	GT-VRK-015
2	GT-BRK-020	GT-ERK-020	GT-VRK-020
2-1/2 & 3	GT-BRK-030	GT-ERK-030	GT-VRK-030
4	GT-BRK-040	GT-ERK-040	GT-VRK-040

**Gate Valve  
Internal Replacement Cartridge**

Includes complete internal assembly with bonnet and handle.

Size	Part Number <sup>1</sup>		
	w/Buna-N O-rings	w/EPDM O-rings	w/FKM O-rings
1/2	2010-005	2020-005	2030-005
3/4	2010-007	2020-007	2030-007
1	2010-010	2020-010	2030-010
1-1/4 & 1-1/2	2010-015	2020-015	2030-015
2	2010-020	2020-020	2030-020

<sup>1</sup> For CPVC Cartridge Kit, add the letter "C" to part numbers listed (e.g., 2010-005C).



## Butterfly Valve Standard & True Lug Seat Repair Kit

Standard Valve and True Lug Kit through 12" includes Buna-N, EPDM or FKM seat (1) and PVC or CPVC seal carrier (1).

Sizes 14" and larger include EPDM or FKM seat only.

Size	PVC Part Number <sup>1,2</sup>		
	w/Buna-N	w/EPDM	w/FKM
1-1/2	BF-BRK-015	BF-ERK-015	BF-VRK-015
2	BF-BRK-020	BF-ERK-020	BF-VRK-020
2-1/2	BF-BRK-025	BF-ERK-025	BF-VRK-025
3	BF-BRK-030	BF-ERK-030	BF-VRK-030
4	BF-BRK-040	BF-ERK-040	BF-VRK-040
6	BF-BRK-060	BF-ERK-060	BF-VRK-060
8	BF-BRK-080	BF-ERK-080	BF-VRK-080
10	BF-BRK-100	BF-ERK-100	BF-VRK-100
12	BF-BRK-120	BF-ERK-120	BF-VRK-120
14	—	BF-ERK-140	BF-VRK-140
16	—	BF-ERK-160	BF-VRK-160
18	—	BF-ERK-180	BF-VRK-180
20	—	BF-ERK-200	BF-VRK-200
24	—	BF-ERK-240	BF-VRK-240

1: For CPVC Seat Replacement Kit, add a "C" to the end of the part number shown (e.g., BF-BRK-015C).

2: For PP, add a "P" to the end of the part number (e.g., BF-BRK-015P).

## Butterfly Valve Standard Valve Overhaul Kit

For standard sizes through 12" includes stem nut (1), stem bushing (1), bushing O-ring (2), stem O-ring (2), stem washer - hex (1), stem washer - round (1), timing stop (1), seat (1), seal carrier (1), disc O-ring (2) and stem bearing (1).

Sizes 14" and larger includes stem nut (1) 14" only, stem bearing (1), bearing O-ring (1), stem bushing (1), bushing O-ring (3), seal carrier (1), seat (1) and stem O-ring (2) 16" and larger only.

Size	PVC Part Number <sup>1,2</sup>		
	w/Buna-N	w/EPDM	w/FKM
1-1/2	BF-BOK-015	BF-EOK-015	BF-VOK-015
2	BF-BOK-020	BF-EOK-020	BF-VOK-020
2-1/2	BF-BOK-025	BF-EOK-025	BF-VOK-025
3	BF-BOK-030	BF-EOK-030	BF-VOK-030
4	BF-BOK-040	BF-EOK-040	BF-VOK-040
6	BF-BOK-060	BF-EOK-060	BF-VOK-060
8	BF-BOK-080	BF-EOK-080	BF-VOK-080
10	BF-BOK-100	BF-EOK-100	BF-VOK-100
12	BF-BOK-120	BF-EOK-120	BF-VOK-120
14	—	BF-EOK-140	BF-VOK-140
16	—	BF-EOK-160	BF-VOK-160
18	—	BF-EOK-180	BF-VOK-180
20	—	BF-EOK-200	BF-VOK-200
24	—	BF-EOK-240	BF-VOK-240

1: CPVC Standard Valve Overhaul Kit available through 12" only. Add a "C" to the end of the part number shown (e.g., BF-BOK-015C).

2: For PP, add a "P" to the end of the part number (e.g., BF-BOK-015P).

## Important Repair & Overhaul Kit Note

Ongoing Butterfly Valve design improvements have resulted in variations to repair kits. Standard cataloged kits are for current 72 part number series, dry-stem type valve revision. Kits for previous revisions are available and can be determined by valve serial number. When ordering kits, please specify valve size, material (PVC, CPVC, PP), Standard or True Lug type valve, Buna-N, EPDM or FKM elastomer material, and valve serial number stamped on the bottom of the valve body to insure proper kit selection. Stainless Steel Stems are normally not replaced, but can be ordered separately on request.

## Butterfly Valve True Lug Valve Overhaul Kit

Includes stem nut (1), stem bushing (1), bushing O-ring (1), stem O-ring (1), stem washer - hex (1), stem washer - round (1), timing stop (1), seat (1), seal carrier (1), seal carrier, flange O-ring (1), disc O-ring (2) and stem bearing (1).

Size	PVC Part Number <sup>1</sup>		
	w/Buna-N	w/EPDM	w/FKM
1-1/2	BFT-BOK-015	BFT-EOK-015	BFT-VOK-015
2	BFT-BOK-020	BFT-EOK-020	BFT-VOK-020
2-1/2	BFT-BOK-025	BFT-EOK-025	BFT-VOK-025
3	BFT-BOK-030	BFT-EOK-030	BFT-VOK-030
4	BFT-BOK-040	BFT-EOK-040	BFT-VOK-040
6	BFT-BOK-060	BFT-EOK-060	BFT-VOK-060
8	BFT-BOK-080	BFT-EOK-080	BFT-VOK-080
10	BFT-BOK-100	BFT-EOK-100	BFT-VOK-100
12	BFT-BOK-120	BFT-EOK-120	BFT-VOK-120

1: For CPVC True Lug Valve Overhaul Kit, add a "C" to the end of the part number shown (e.g., BFT-BOK-015C).

## Butterfly Valve True Lug Valve Overhaul Kit with Disc

Includes stem nut (1), stem bushing (1), bushing O-ring (1), stem O-ring (1), stem washer - hex (1), stem washer - round (1), timing stop (1), seat (1), seal carrier (1) seal carrier flange O-ring (1), disc (1), disc O-ring (2) and stem bearing (1).

Size	Part Number <sup>1</sup>		
	w/Buna-N	w/EPDM	w/FKM
1-1/2	BFT-BOKD-015	BFT-EOKD-015	BFT-VOKD-015
2	BFT-BOKD-020	BFT-EOKD-020	BFT-VOKD-020
2-1/2	BFT-BOKD-025	BFT-EOKD-025	BFT-VOKD-025
3	BFT-BOKD-030	BFT-EOKD-030	BFT-VOKD-030
4	BFT-BOKD-040	BFT-EOKD-040	BFT-VOKD-040
6	BFT-BOKD-060	BFT-EOKD-060	BFT-VOKD-060
8	BFT-BOKD-080	BFT-EOKD-080	BFT-VOKD-080
10	BFT-BOKD-100	BFT-EOKD-100	BFT-VOKD-100
12	BFT-BOKD-120	BFT-EOKD-120	BFT-VOKD-120

1: For CPVC True Lug Valve Overhaul Kit with Disc, add a "C" to the end of the part number shown (e.g., BFT-BOKD-015C).





## Thermoplastic Valves Product Guide & Engineering Specifications

### Valve Service & Replacement Kits

### Butterfly Valve Standard Valve Overhaul Kit with Disc

For standard sizes through 12" includes stem nut (1), stem bushing (1), bushing O-ring (2), stem O-ring (2), stem washer - hex (1), stem washer - round (1), timing stop (1), seat (1), seal carrier (1), disc (1), disc O-ring (2) and stem bearing (1).

Sizes 14" and larger includes stem nut (1) 14" only, stem bearing (1), bearing O-ring (1), stem bushing (1), bushing O-ring (3), disc (1), seal carrier (1), seat (1) and stem O-ring (2) 16" and larger only.

Size	Part Number <sup>1,2</sup>		
	w/Buna-N	w/EPDM	w/FKM
1-1/2	BF-BOKD-015	BF-EOKD-015	BF-VOKD-015
2	BF-BOKD-020	BF-EOKD-020	BF-VOKD-020
2-1/2	BF-BOKD-025	BF-EOKD-025	BF-VOKD-025
3	BF-BOKD-030	BF-EOKD-030	BF-VOKD-030
4	BF-BOKD-040	BF-EOKD-040	BF-VOKD-040
6	BF-BOKD-060	BF-EOKD-060	BF-VOKD-060
8	BF-BOKD-080	BF-EOKD-080	BF-VOKD-080
10	BF-BOKD-100	BF-EOKD-100	BF-VOKD-100
12	BF-BOKD-120	BF-EOKD-120	BF-VOKD-120
14	—	BF-EOKD-140	BF-VOKD-140
16	—	BF-EOKD-160	BF-VOKD-160
18	—	BF-EOKD-180	BF-VOKD-180
20	—	BF-EOKD-200	BF-VOKD-200
24	—	BF-EOKD-240	BF-VOKD-240

1: CPVC Standard Valve Overhaul Kit available through 12" only. Add a "C" to the end of the part number shown (e.g., BF-BOKD-015C).

2: For PP, add a "P" to the end of the part number (e.g., BF-BOKD-015P).

### Wafer Butterfly Valve Overhaul Kit

All Kits include Seat (1), Flange Gaskets (2), Stem Bushing O-rings (2), Bushing Washers (2), Stem Bushings (2).

Size	Part Number		
	w/Buna-N	w/EPDM	w/FKM
2	BFW-BOK-020	BFW-EOK-020	BFW-VOK-020
2-1/2	BFW-BOK-025	BFW-EOK-025	BFW-VOK-025
3	BFW-BOK-030	BFW-EOK-030	BFW-VOK-030
4	BFW-BOK-040	BFW-EOK-040	BFW-VOK-040
6	BFW-BOK-060	BFW-EOK-060	BFW-VOK-060
8	BFW-BOK-080	BFW-EOK-080	BFW-VOK-080
10	BFW-BOK-100	BFW-EOK-100	BFW-VOK-100
12	BFW-BOK-120	BFW-EOK-120	BFW-VOK-120



### Wafer Butterfly Valve Overhaul Kit w/Disc

All Kits include Seat (1), Flange Gaskets (2), Stem Bushing O-rings (2), Stem Bushing Washers (2), Stem Bushings (2), Replacement Disc (1).

Size	Part Number <sup>1</sup>		
	w/Buna-N	w/EPDM	w/FKM
2	BFW-BOKD-020	BFW-EOKD-020	BFW-VOKD-020
2-1/2	BFW-BOKD-025	BFW-EOKD-025	BFW-VOKD-025
3	BFW-BOKD-030	BFW-EOKD-030	BFW-VOKD-030
4	BFW-BOKD-040	BFW-EOKD-040	BFW-VOKD-040
6	BFW-BOKD-060	BFW-EOKD-060	BFW-VOKD-060
8	BFW-BOKD-080	BFW-EOKD-080	BFW-VOKD-080
10	BFW-BOKD-100	BFW-EOKD-100	BFW-VOKD-100
12	BFW-BOKD-120	BFW-EOKD-120	BFW-VOKD-120

1: For CPVC Overhaul Kits with Disc available in EPDM or FKM only. Add a "C" to the end of the part number shown (e.g., BFW-EOKD-020C).

### Wafer Butterfly Valve Overhaul Kit

All Kits include Seat (1), Flange Gaskets (2).

Size	Part Number		
	w/Buna-N	w/EPDM	w/FKM
2	BFW-BRK-020	BFW-ERK-020	BFW-VRK-020
2-1/2	BFW-BRK-025	BFW-ERK-025	BFW-VRK-025
3	BFW-BRK-030	BFW-ERK-030	BFW-VRK-030
4	BFW-BRK-040	BFW-ERK-040	BFW-VRK-040
6	BFW-BRK-060	BFW-ERK-060	BFW-VRK-060
8	BFW-BRK-080	BFW-ERK-080	BFW-VRK-080
10	BFW-BRK-100	BFW-ERK-100	BFW-VRK-100
12	BFW-BRK-120	BFW-ERK-120	BFW-VRK-120

### Industrial Swing Check Valve Seat & O-ring Repair Kit

All kits include Bonnet O-ring (1), Disc O-ring (1), Seat O-ring (1), Plug O-ring (1) and Arm Plug O-ring (1).

Size	Part Number	
	w/EPDM O-rings	w/FKM O-rings
3/4	SK-ERK-007	SK-VRK-007
1	SK-ERK-010	SK-VRK-010
1-1/4	SK-ERK-012	SK-VRK-012
1-1/2	SK-ERK-015	SK-VRK-015
2	SK-ERK-020	SK-VRK-020
2-1/2 & 3	SK-ERK-030	SK-VRK-030
4	SK-ERK-040	SK-VRK-040
6	SK-ERK-060	SK-VRK-060
8	SK-ERK-080	SK-VRK-080

### Butterfly Check Valve Repair Kit

Repair Kit Contains: 1-Flex Seal Gasket Seat, 1-Hinge Post, 2-Flapper Plates, 2-Flapper Covers, 1-Post Strip, 2-Seat Post O-rings & Plastic Assembly Screws.

**Use Existing Hinge post Bolts**

Size	Part Number <sup>1</sup>	
	w/EPDM O-rings	w/FKM O-rings
2	BFC-ERK-020	BFC-VRK-020
2-1/2	BFC-ERK-025	BFC-VRK-025
3	BFC-ERK-030	BFC-VRK-030
4	BFC-ERK-040	BFC-VRK-040
6	BFC-ERK-060	BFC-VRK-060
8	BFC-ERK-080	BFC-VRK-080
10	BFC-ERK-100	BFC-VRK-100
12	BFC-ERK-120	BFC-VRK-120

1: For CPVC Butterfly Check Valve Repair Kit, add a "C" to the end of the part number shown (e.g., BFC-ERK-020C).



### Y-Pattern Valve - Internal Repair Kit

Internal Repair Kit includes: Stem O-ring (1), Seal Carrier (1), along with a factory assembled (required) internal component replacement unit consisting of Stem assembled with Seat & Seal Carrier components. Install in valve using existing valve Bonnet, Bonnet Nut, and Handle/Nut. True Union style valve kits include additional End Connector O-rings (2).

Size	Part Number							
	w/EPDM O-ring	CPVC w/ EPDM O-ring	w/FKM O-ring	CPVC w/FKM O-ring	Union w/ EPDM O-ring	CPVC Union w/ EPDM O-ring	Union w/ FKM O-ring	CPVC Union w/ FKM O-ring
1/2	YV-ERK-005	YV-ERK-005C	YV-VRK-005	YV-VRK-005C	YV-UERK-005	YV-UERK-005C	YV-UVRK-005	YV-UVRK-005C
3/4	YV-ERK-007	YV-ERK-007C	YV-VRK-007	YV-VRK-007C	YV-UERK-007	YV-UERK-007C	YV-UVRK-007	YV-UVRK-007C
1	YV-ERK-010	YV-ERK-010C	YV-VRK-010	YV-VRK-010C	YV-UERK-010	YV-UERK-010C	YV-UVRK-010	YV-UVRK-010C
1-1/4	YV-ERK-012	YV-ERK-012C	YV-VRK-012	YV-VRK-012C	YV-UERK-012	YV-UERK-012C	YV-UVRK-012	YV-UVRK-012C
1-1/2	YV-ERK-015	YV-ERK-015C	YV-VRK-015	YV-VRK-015C	YV-UERK-015	YV-UERK-015C	YV-UVRK-015	YV-UVRK-015C
2	YV-ERK-020	YV-ERK-020C	YV-VRK-020	YV-VRK-020C	YV-UERK-020	YV-UERK-020C	YV-UVRK-020	YV-UVRK-020C
3	YV-ERK-030	YV-ERK-030C	YV-VRK-030	YV-VRK-030C	YV-UERK-030	YV-UERK-030C	YV-UVRK-030	YV-UVRK-030C
4	YV-ERK-040	YV-ERK-040C	YV-VRK-040	YV-VRK-040C	YV-UERK-040	YV-UERK-040C	YV-UVRK-040	YV-UVRK-040C

### Y-Check Valve - Seat & O-ring Repair Kit

All Kits include Seat (1), Bonnet O-ring (1), and Plug O-ring (1).

All True Union Kits include Seat (1), Bonnet O-ring (1), Plug O-ring (1), and End Connector O-rings (2).

Size	Part Number			
	w/EPDM O-ring	w/FKM O-ring	Union w/EPDM O-ring	Union w/FKM O-ring
1/2	YC-ERK-005	YC-VRK-005	YC-UERK-005	YC-UVRK-005
3/4	YC-ERK-007	YC-VRK-007	YC-UERK-007	YC-UVRK-007
1	YC-ERK-010	YC-VRK-010	YC-UERK-010	YC-UVRK-010
1-1/4	YC-ERK-012	YC-VRK-012	YC-UERK-012	YC-UVRK-012
1-1/2	YC-ERK-015	YC-VRK-015	YC-UERK-015	YC-UVRK-015
2	YC-ERK-020	YC-VRK-020	YC-UERK-020	YC-UVRK-020
3	YC-ERK-030	YC-VRK-030	YC-UERK-030	YC-UVRK-030
4	YC-ERK-040	YC-VRK-040	YC-UERK-040	YC-UVRK-040

### Diaphragm Valve - Diaphragm & End Connector O-ring Replacement Kit

Includes diaphragm (1), and end connector O-rings (2).

Size	Part Number				
	EPDM O-ring & DIAPHRAGM KIT	EPDM O-ring & PTFE* DIAPHRAGM KIT	FKM O-ring & DIAPHRAGM KIT	FKM O-ring & PTFE* DIAPHRAGM KIT	FKM O-ring & FKM Backed Diaphragm Kit
1/2	DV-ERK-005	DV-TERK-005	DV-VRK-005	DV-TVVK-005	DV-VTVRK-005
3/4	DV-ERK-007	DV-TERK-007	DV-VRK-007	DV-TVVK-007	DV-VTVRK-007
1	DV-ERK-010	DV-TERK-010	DV-VRK-010	DV-TVVK-010	DV-VTVRK-010
1-1/4 or 1-1/2	DV-ERK-015	DV-TERK-015	DV-VRK-015	DV-TVVK-015	DV-VTVRK-015
2	DV-ERK-020	DV-TERK-020	DV-VRK-020	DV-TVVK-020	DV-VTVRK-020

\* Elastomer backed PTFE laminated diaphragm.



### Diaphragm Valve - Replacement Diaphragm

Size	Part Number			
	EPDM DIAPHRAGM	FKM DIAPHRAGM	PTFE* DIAPHRAGM	FKM backed PTFE* DIAPHRAGM
1/2	27-39-00541	27-39-00542	27-39-00565	27-39-00566A
3/4	27-39-00741	27-39-00742	27-39-00765	27-39-00766A
1	27-39-01041	27-39-01042	27-39-01065	27-39-01066A
1-1/4 or 1-1/2	27-39-01541	27-39-01542	27-39-01565	27-39-01566
2	27-39-02041	27-39-02042	27-39-02065	27-39-02066
2-1/2 or 3	27-39-03041	27-39-03042	27-39-03065	27-39-03066
4	27-39-04041	27-39-04042	27-39-04065	27-39-04066
6	27-39-06041	27-39-06042	27-39-06065	27-39-06066
8	27-39-08041	27-39-08042	27-39-08065	27-39-08066

\* Elastomer backed PTFE laminated diaphragm.