

## 599 Series

### 3-Way Ball Valves



#### Description

The 599 Series 3-way Ball Valves are coupled with an OpenAir™ actuator to provide three-way mixing or diverting flow control. The ball valves are 1/4-turn rotary control valves and are available in 1/2-inch to 2-inch line sizes.

#### Features

- ANSI 250 valve body rating.
- 200 psi close-off with ANSI Class IV leakage for all line sizes and actuators.
- Available with chrome-plated brass ball and brass stem or 316 stainless steel ball and stem.
- Can be used as either a mixing or a diverting valve.
- Blow-out proof stem withstands high pressure.
- Universal mounting plate.
- Actuator and plate can be rotated (90-degree increments).
- Standoffs provide a thermal barrier between the actuator and the mounting plate.
- Operating handle for manual operation.
- All ball valve actuators include integral conduit adapters.

#### Warning/Caution Notations

<b>WARNING:</b>		Personal injury or loss of life may occur if you do not perform a procedure as specified.
<b>CAUTION:</b>		Equipment damage or loss of data may occur if you do not perform a procedure as specified.

#### Product Numbers

See *TB 253 599 Series Ball Valve and Actuator Assemblies Selection Technical Bulletin* (155-704P25) for selection procedures and ordering numbers.

Individual ball valves can be ordered using the product numbers in Table 2.

#### Accessories/Kits

599-10078	Ball Valve Bracket Kit (includes bracket, mounting screws, shaft and handle)
599-10080	Ball Valve Weather Shield (provides NEMA 3R protection)

## Ordering a Valve Plus Actuator Assembly

To order a complete valve plus actuator assembly from the factory, combine an actuator prefix code (Table 1) with the suffix of the valve assembly product number.

**Table 1. Actuator Prefix Codes.**

Actuator Prefix Code	OpenAir Actuator *	Control
171A	GDE131.1P	3-position, fail-in-place
171B	GLB131.1P	3-position, fail-in-place
171C	GDE161.1P	0 to 10 Vdc, fail-in-place
171D	GLB161.1P	0 to 10 Vdc, fail-in-place
171E	GMA121.1P**	2-position, fail-safe
171F	GMA131.1P**	3-position, fail-safe
171G	GMA161.1P**	0 to 10 Vdc, fail-safe

\* When ordered as an assembly, the actuator is provided with 3-foot (.9m) wires.

\*\* Fails with A ► AB open.

<b>Specifications</b>	Body	Forged Brass ASTM B283	
	Flow optimizer	Glass-filled polymer	
	<b>Material</b>	Ball	Chrome-plated brass or 316 stainless steel
		Ball seals	Reinforced PTFE seals with EPDM O-rings
	Female end connections	Brass	
	Stem	Brass or 316 stainless steel	
	Stem seals	EPDM O-rings	
<b>Operating</b>	Valve body rating	ANSI 250/600 WOG	
	Static pressure	360 psi (2482 kPa)	
	Media temperature		
	1/2-inch to 1-1/2 inch	0°F to 250°F (-18°C to 121°C)	
	1-1/2 inch and 2-inch	0°F to 230°F (-18°C to 110°C)	
	Controlled media	Water, glycol solutions to 50%	
	Angle of rotation	0 to 90°	
	Flow coefficients	See Table 2 and Table 3.	
	Close-off ratings	See Table 2	
	Maximum operating differential pressure	Close-off ratings per ANSI/FCI 70-2: Class IV for A-AB, Class III for B-AB	
Flow rates	60 psi (35 psi for 2" valves)		
<b>Miscellaneous</b>	Canadian Registration Number	See Table 2.	
	Mounting location	OC8213.5ADD4	
		NEMA 1 (interior only) NEMA 3R (with weathershield)	
	Dimensions, service envelope, weight	See Figure 6 and Table 4.	

**Table 2. 3-Way Ball Valve Product Numbers, Close-off Ratings, and Flow Rates.**

Valve Product Number	Valve Line Size Inches (mm)	Close-Off ΔP in psi (kPa)	Cv (Kvs)	Flow Rate, gpm @ Differential Pressure ΔP, psi (Flow Rate, m <sup>3</sup> /hr @ Differential Pressure ΔP, kPa)								
				1 (7)	2 (14)	3 (21)	4 (28)	5 (34)	10 (69)	15 (103)	20 (138)	25 (172)
599-10350(S)	1/2 (15)	200 (1379)	0.40 (0.34)	0.57 (0.13)	0.69 (0.16)	0.80 (0.18)	0.89 (0.20)	1.3 (0.29)	1.6 (0.35)	1.8 (0.41)	2.0 (0.45)	2.2 (0.50)
599-10351(S)			0.63 (0.54)	0.89 (0.20)	1.1 (0.25)	1.3 (0.29)	1.4 (0.32)	2.0 (0.45)	2.4 (0.55)	2.8 (0.64)	3.2 (0.72)	3.5 (0.78)
599-10352(S)			1.0 (0.86)	1.4 (0.32)	1.7 (0.39)	2.0 (0.45)	2.2 (0.51)	3.2 (0.72)	3.9 (0.88)	4.5 (1.0)	5.0 (1.1)	5.5 (1.2)
599-10353(S)			1.6 (1.4)	2.3 (0.51)	2.8 (0.63)	3.2 (0.73)	3.6 (0.81)	5.1 (1.2)	6.2 (1.4)	7.2 (1.6)	8.0 (1.8)	8.8 (2.0)
599-10354(S)			2.5 (2.2)	3.5 (0.80)	4.3 (1.0)	5.0 (1.1)	5.6 (1.3)	7.9 (1.8)	9.7 (2.2)	11.2 (2.5)	12.5 (2.8)	13.7 (3.1)
599-10355(S)			4 (3.5)	5.7 (1.3)	6.9 (1.6)	8.0 (1.8)	8.9 (2.0)	13 (2.9)	16 (3.5)	18 (4.1)	20 (4.5)	22 (5.0)
599-10356(S)			6.3 (5.5)	8.9 (2.0)	11 (2.5)	13 (2.9)	14 (3.2)	20 (4.5)	24 (5.5)	28 (6.4)	32 (7.2)	35 (7.8)
599-10357(S) *			10 (8.6)	14 (3.2)	17 (3.9)	20 (4.5)	22 (5.1)	32 (7.2)	39 (8.8)	45 (10)	50 (11)	55 (12)
599-10358(S)	3/4 (20)	200 (1379)	6.3 (5.5)	8.9 (2.0)	11 (2.5)	13 (2.9)	14 (3.2)	20 (4.5)	24 (5.5)	28 (6.4)	32 (7.2)	35 (7.8)
599-10359(S)			10 (8.6)	14 (3.2)	17 (3.9)	20 (4.5)	22 (5.1)	32 (7.2)	39 (8.8)	45 (10)	50 (11)	55 (12)
599-10360(S) *			16 (14)	23 (5.1)	28 (6.3)	32 (7.3)	36 (8.1)	51 (11)	62 (14)	72 (16)	80 (18)	88 (20)
599-10361(S)	1 (25)	200 (1379)	10 (8.6)	14 (3.2)	17 (3.9)	20 (4.5)	22 (5.1)	32 (7.2)	39 (8.8)	45 (10)	50 (11)	55 (12)
599-10362(S)			16 (14)	23 (5.1)	28 (6.3)	32 (7.3)	36 (8.1)	51 (11)	62 (14)	72 (16)	80 (18)	88 (20)
599-10363(S) *			25 (22)	35 (8.0)	43 (9.8)	50 (11)	56 (13)	79 (18)	97 (22)	112 (25)	125 (28)	137 (31)
599-10364(S)	1-1/4 (32)	200 (1379)	16 (14)	23 (5.1)	28 (6.3)	32 (7.3)	36 (8.1)	51 (11)	62 (14)	72 (16)	80 (18)	88 (20)
599-10365(S)			25 (22)	35 (8.0)	43 (9.8)	50 (11)	56 (13)	79 (18)	97 (22)	112 (25)	125 (28)	137 (31)
599-10366(S) *			40 (35)	57 (13)	69 (16)	80 (18)	89 (20)	126 (29)	155 (35)	179 (41)	200 (45)	219 (50)
599-10367(S)	1-1/2 (40)	200 (1379)	25 (22)	35 (8.0)	43 (9.8)	50 (11)	56 (13)	79 (18)	97 (22)	112 (25)	125 (28)	137 (31)
599-10368(S)			40 (35)	57 (13)	69 (16)	80 (18)	89 (20)	126 (29)	155 (35)	179 (41)	200 (45)	219 (50)
599-10369(S) *			63 (54)	89 (20)	109 (25)	126 (29)	141 (32)	199 (45)	244 (55)	282 (64)	315 (72)	345 (78)
599-10370(S)	2 (50)	200 (1379)	40 (35)	57 (13)	69 (16)	80 (18)	89 (20)	126 (29)	155 (35)	179 (41)	200 (45)	219 (50)
599-10371(S)			63 (54)	89 (20)	109 (25)	126 (29)	141 (32)	199 (45)	244 (55)	282 (64)	315 (72)	345 (78)
599-10372(S)			100 (86)	141 (32)	173 (39)	200 (45)	224 (51)	316 (72)	387 (88)	447 (102)	500 (114)	548 (124)

\* Denotes a full-port valve without flow optimizer insert.

**NOTE:** Maximum operating differential pressure = 60 psi for 1/2" to 1-1/2"; 50 psi for 2" valves.

Use Table 3 to determine the effective Cv when using a full-port ball valve where the ball size and the lines size differ.

**Table 3. Full-Port (No Flow Optimizer) 3-Way Ball Valve Product Numbers and Flow Coefficients.**

Valve Line Size in Inches (mm)	Valve Product Number	Effective (Installed) Cv (Kvs)										
		Supply Line Size in Inches (mm)										
		1/2 (13)	3/4 (20)	1 (25)	1-1/4 (32)	1-1/2 (38)	2 (51)	2-1/2 (63)	3 (76)	4 (102)	5 (127)	6 (152)
1/2 (15)	599-10357(S)	10.00 (8.62)	6.94 (5.93)	6.19 (5.29)	--	--	--	--	--	--	--	--
3/4 (20)	599-10360(S)	--	16.00 (13.79)	13.9 (11.98)	12.4 (10.69)	--	--	--	--	--	--	--
1 (25)	599-10363(S)	--	--	25.00 (21.55)	22.5 (19.40)	21.2 (18.27)	--	--	--	--	--	--
1-1/4 (32)	599-10366(S)	--	--	--	40.00 (34.48)	36.9 (31.81)	33.3 (28.70)	--	--	--	--	--
1-1/2 (40)	599-10369(S)	--	--	--	--	63.00 (54.31)	55.3 (47.67)	51.00 (43.96)	--	--	--	--
2 (50)	599-10372(S)	--	--	--	--	--	100 (86.21)	94.3 (81.29)	86.1 (74.23)	--	--	--

= Valve may be oversized.
  = Optimal valve size.
  = Valve may be undersized.

## Application

Ball valves can control hot or chilled water and up to 50% glycol solution in mixing applications for air handlers, convectors, fan coil units, unit conditioners, radiation, and reheat coils. Three-way ball valves can be piped for either mixing or diverting applications. See Figure 1 and Figure 2 for piping configurations for mixing and diverting applications, respectively.

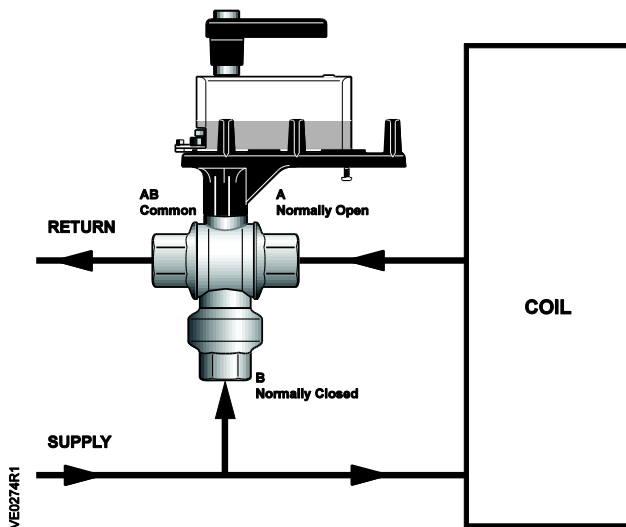

Figure 1. Mixing Application.

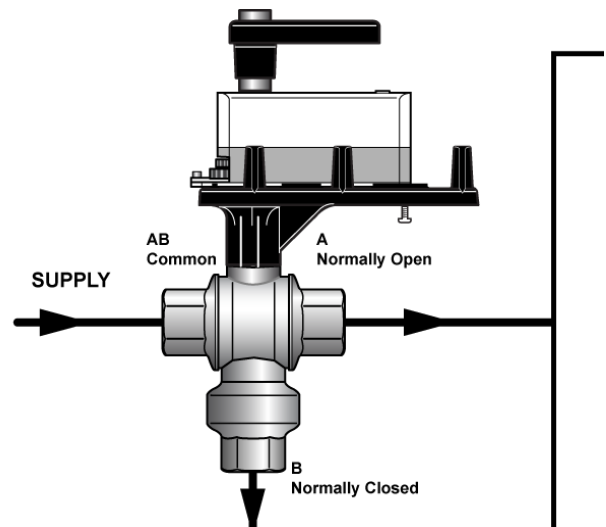

Figure 2. Three-way Diverting Application.

## Operation

The parabolic shape of the control port (A – AB) flow optimizer orifice (Figure 3) provides a slowly opening valve. Equal movements of the valve stem, at any point of the flow range, change the existing flow an equal percentage regardless of the existing flow. The ball valve equal percentage flow characteristic (Figure 4) mirrors the flow characteristic of a coil, resulting in linear heat transfer.

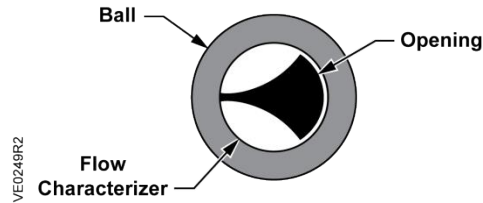

Figure 3. Ball Valve Flow Optimizer.

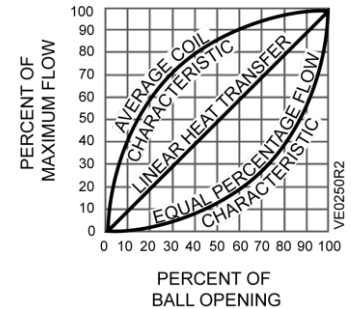

Figure 4. Ball Valve Equal Percentage Flow Control.

## Mounting and Installation

- Install the valve so that the flow follows the direction of the arrow cast on the valve body.

**NOTE:** Note: Valves with body part numbers -103xx may be installed as diverting valves.

- For added flexibility, the actuator mounting plate can be installed in any of the four (4) rotation angles relative to the valve body. See Figure 5.
- For best performance, install the valve assembly with the actuator above the valve body.
- The valve and actuator assembly can be installed in a horizontal pipe in any position between vertical and 90°. Do not install the valve assembly so that the actuator is below horizontal or upside-down.
- The ball valve also can be installed vertically.
- Allow sufficient space for servicing the valve and actuator. See Figure 6 for valve body dimensions and service envelope.

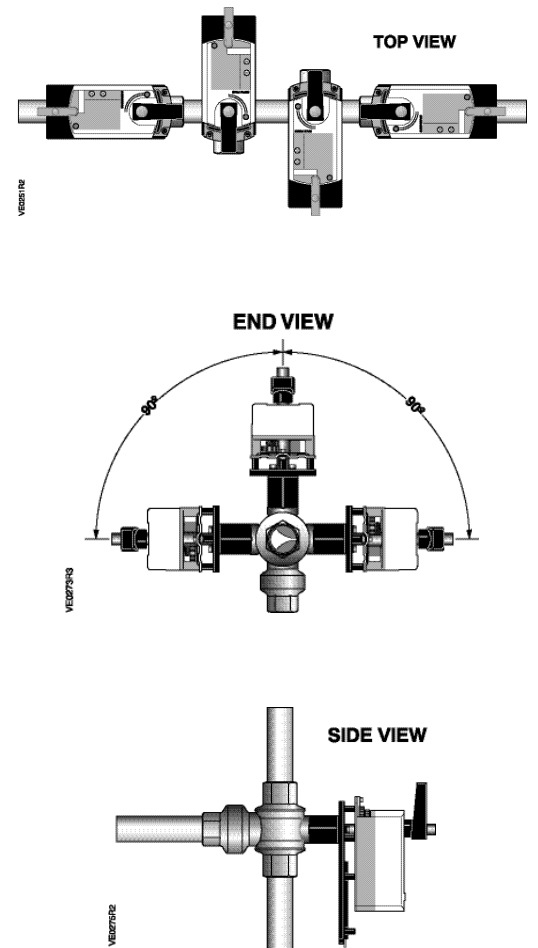
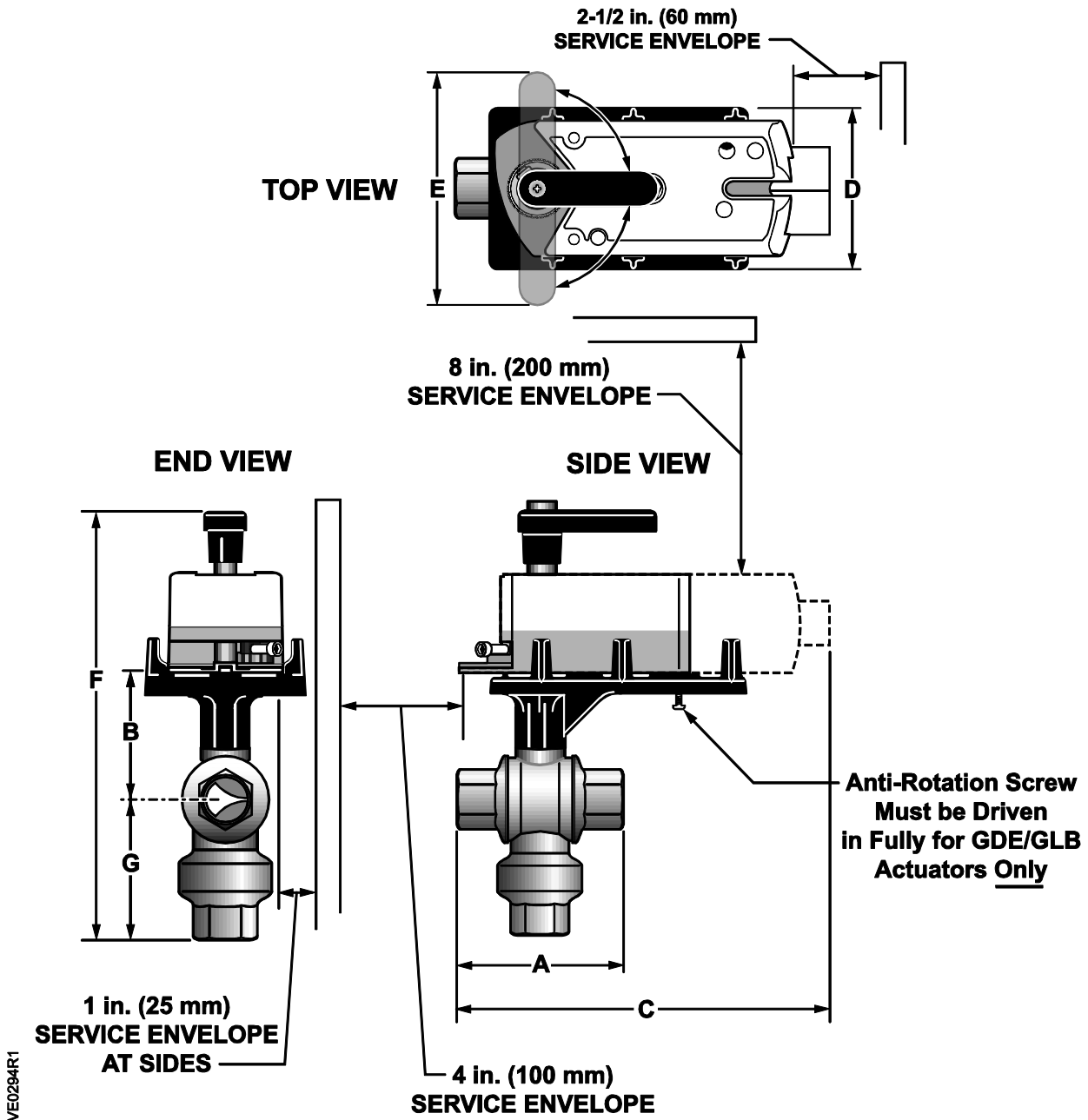

Figure 5. Mounting Positions.

## Service

Replace the valve or actuator if inoperable.

## Dimensions



**NOTES:**

1. All dimensions are in inches (mm) and weights are in pounds (kg).
2. Dimension D, Depth, is 3 inches (76 mm).
3. Dimension E, Handle, is 4 inches (102 mm).

**Figure 6. Dimensions and Service Envelope.**

**Table 4. Dimensions and Service Envelope.**

Line Size Inches (mm)	Product Number	A Length	C Length * for Actuator Codes 171A-D	C Length * for Actuator Codes 171E-G	B Height	G Height	F Height	Weight lbs (kg)
1/2 (15)	599-10350(S) through 599-10357(S)	2-9/16 (65)	6-11/16 (170)	7-3/4 (197)	3-1/4 (83)	1-3/8 (35)	8-5/8 (219)	1.50 (0.68)
3/4 (20)	599-10358(S) 599-10359(S)	2-3/4 (70)	6-11/16 (170)	8 (203)	3-1/4 (83)	1-3/8 (35)	8-5/8 (219)	1.60 (0.73)
	599-10360(S)	3-1/8 (79)				1-11/16 (43)		2.20 (1.00)
1 (25)	599-10361(S)	3-1/8 (79)	6-11/16 (170)	8 (203)	3-3/4 (95)	1-11/16 (43)	9-1/8 (232)	2.37 (1.08)
	599-10362(S) 599-10363(S)	3-13/16 (97)	6-15/16 (176)	8-1/2 (216)	4 (102)	2 (51)	9-5/8 (244)	2.74 (1.24)
1-1/4 (32)	599-10364(S) 599-10365(S)	3-5/8 (92)	6-7/8 (174)	8-1/2 (216)	4 (102)	2-1/8 (54)	9-3/4 (248)	3.50 (1.59)
	599-10366(S)	3-15/16 (100)	7 (178)	8-1/2 (216)		2-5/16 (59)	10-1/4 (260)	4.30 (1.95)
1-1/2 (40)	599-10367(S) 599-10368(S)	3-15/16 (100)	7 (178)	8-1/2 (216)	4 (102)	2-5/16 (59)	10-1/4 (260)	3.90 (1.76)
	599-10369(S)	4-5/8 (117)	7-1/4 (184)	8-3/4 (222)	4-1/2 (114)	2-13/16 (71)	11 (279)	7.83 (3.55)
2 (50)	599-10370(S)	4-5/8 (117)	7-1/4 (184)	8-3/4 (222)	4-1/2 (114)	2-7/8 (73)	10-3/8 (264)	6.70 (3.04)
	599-10371(S) 599-10372(S)				5-3/4 (146)		11-3/16 (284)	

\* Dimension C is maximum length, measured from the actuator, end fitting, or mounting plate, whichever extends the furthest.

Information in this publication is based on current specifications. The company reserves the right to make changes in specifications and models as design improvements are introduced. OpenAir is a registered trademark of Siemens Schweiz AG. Other product or company names mentioned herein may be the trademarks of their respective owners. © 2020-2025 Siemens Industry, Inc.