

SIEMENS

Siemens BT300 HVAC Drive Operator's Manual

Copyright Notice

Notice

Document information is subject to change without notice by Siemens Industry, Inc. Companies, names, and various data used in examples are fictitious unless otherwise noted. No part of this document may be reproduced or transmitted in any form or by any means, electronic or mechanical, for any purpose, without the express written permission of Siemens Industry, Inc.

Warning

This equipment generates, uses, and can radiate radio frequency energy. If equipment is not installed and used in accordance with the instructions manual, it may cause interference to radio communications. Equipment has been tested and found to comply within the limits for a Class B digital device pursuant to Part 15 of the FCC rules. These limits are designed to provide reasonable protection against such interference when operated in a commercial environment. Operation of this equipment in a residential area is likely to cause interference. Residential area equipment users are required to take whatever measures necessary to correct the interference at their own expense.

Service Statement

Control devices are combined to make a system. Each control device is mechanical in nature and all mechanical components must be regularly serviced to optimize their operation. Siemens Industry, Inc. branch offices and authorized distributors offer Technical Support Programs that will ensure continuous, trouble-free system performance.

For further information, contact your nearest Siemens Industry representative.

Copyright 2019 Siemens Industry, Inc.

FCC Regulations

The manual for an intentional or unintentional radiator shall caution the user that changes or modifications not expressly approved by the party responsible could void the user's authority to operate the equipment.

For a Class B digital device or peripheral, the instructions furnished the user shall include the following or similar statement, placed in a prominent location in the text of the manual:

NOTE: This equipment has been tested and found to comply with the limits for a Class B digital device, pursuant to part 15 of the FCC Rules. These limits are designed to provide reasonable protection against harmful interference in a residential installation. This equipment generates, uses and can radiate radio frequency energy and, if not in-stalled and used in accordance with the instructions, may cause harmful interference to radio communications. However, there is no guarantee that interference will not occur in a particular installation. If this equipment does cause harmful interference to radio or television reception, which can be determined by turning the equipment off and on, the user is encouraged to try to correct the interference by one or more of the following measures:

- *Reorient or relocate the receiving antenna.*
- *Increase the separation between the equipment and receiver.*

-
- *Connect the equipment into an outlet on a circuit different from that to which the receiver is connected.*
 - *Consult the dealer or an experienced radio/TV technician for help.*

To the Reader

Your feedback is important to us. If you have comments about this manual, please submit them to: SBT_technical.editor.us.sbt@siemens.com

Credits

APOGEE is a registered trademark of Siemens Industry, Inc. Other product or company names mentioned herein may be the trademarks of their respective owners.

Printed in the USA.

Table of contents

How to Use this Manual	9
Chapter 1 - User Interfaces on Siemens BT300	11
Drive Keypad.....	11
Keypad Buttons.....	11
Keypad Display.....	12
Using the Keypad.....	13
NET (Software Tool).....	15
Fieldbus.....	16
Chapter 2 - Control Board Terminal Connections	17
Analog Input Terminal Connections.....	18
Analog Input 1.....	18
Analog Input 2.....	18
Digital Input Terminal Connections.....	19
Digital Inputs 1 through 6.....	19
Analog Output Terminal Connections.....	19
Analog Output 1.....	19
Digital Output Terminal Connections.....	20
Chapter 3 - Start-up Information	21
Procedure and Checklist.....	21
Commissioning Flowchart.....	21
Wizards.....	22
Startup Wizard (P1.19).....	22
PID Mini-Wizard (P1.17).....	24
Multi-Pump Wizard (P1.18).....	25
Fire Mode Wizard (P1.20).....	26
Bypass Wizard (P1.21).....	26
Chapter 4 - Parameters and Menu Structure	29
Quick Setup (M1).....	30
Monitor Menu (M2).....	31
Multimonitor (M2.1).....	32
Basic (M2.2).....	32
Timer functions monitoring (M2.3).....	33
PID Controller 1 Monitoring (M2.4).....	34
PID Controller 2 Monitoring (M2.5).....	34
Multi-pump monitoring (M2.6).....	35
Fieldbus data monitoring (M2.8).....	35
Temperature inputs monitoring (M2.9).....	37
Parameters (M3).....	37
Motor Settings (M3.1).....	37

Basic Settings (M3.1.1)	38
Motor Control Settings (M3.1.2)	39
Start/Stop setup (M3.2)	41
Start Function (P3.2.4)	43
Stop Function (P3.2.5)	43
I/O start/stop logic (P3.2.6)	43
Control reference settings (M3.3)	50
Understanding Preset Frequencies	54
Ramp and Brakes Setup (M3.4)	55
I/O Configuration (M3.5)	57
Digital Inputs (M3.5.1)	57
Analog Inputs (M3.5.2)	62
Digital Outputs (M3.5.3)	65
Analog Outputs (M3.5.4)	69
Fieldbus Data Mapping (M3.6)	72
Prohibited Frequencies (M3.7)	75
Limit supervisions (M3.8)	76
Protections (M3.9)	78
Automatic Reset (M3.10)	85
Timer Functions (M3.11)	87
Time Channels	87
Intervals	87
Timers	90
Example	91
PID Controller 1 (M3.12)	92
Basic Settings (M3.12.1)	92
Setpoints (M3.12.2)	93
Feedbacks (M3.12.3)	95
Feedforward (M3.12.4)	97
Process Supervision (M3.12.5)	98
Pressure Loss Compensation (M3.12.6)	99
PID Control Sequence Details	99
PID Controller 2 (M3.13)	104
Basic Settings (M3.13.1)	105
Setpoints (M3.13.2)	105
Feedback (M3.13.3)	106
Process Supervision (M3.13.4)	107
Multi-pump (M3.14)	107
Multi-Pump	108
Fire Mode (M3.16)	112
Application Settings (M3.17)	115
Bypass (M3.18)	115
Diagnostics (M4)	117

Active faults (M4.1)	117
Reset faults (P4.2)	117
Fault History (M4.4)	118
Total Counters (M4.6)	118
Trip Counters (M4.7)	118
Software Info (M4.8)	119
I/O and Hardware (M5)	119
Basic I/O (M5.1)	120
Slot C (M5.2)	120
Slot D (M5.3)	121
Slot E (M5.4)	121
Real time clock (M5.5)	121
Power unit settings (M5.6)	122
Fan (M5.6.1)	122
Sine Filter (M5.6.4)	122
Keypad (M5.7)	122
RS-485 (M5.8)	123
Common Settings (M5.8.1)	124
N2 (M5.8.3)	125
BACnet MS/TP (M5.8.3)	130
P1 FLN (M5.8.3)	138
Modbus RTU (M5.8.3)	143
Ethernet (M5.9)	159
Common Settings (M5.9.1)	159
Modbus TCP (M5.9.2)	160
BACnet IP (M5.9.3)	165
User Settings (M6)	169
Parameter Backup (M6.5)	169
Parameter Compare (M6.6)	170
Favorites (M7)	170
User Levels (M8)	170
Chapter 5 - Fault Tracing	172
Fault Displays	172
Fault history	172
Fault Codes	173
Chapter 6 - Technical Information	178
Product Numbers	178
Power Ratings	179
Interpreting Serial Numbers and Date Codes	179
Technical Data	180
Control Board Technical Specifications	182
Fieldbus Technical Data	183
Accessories and Replacement Parts	184

How to Use this Manual

About This Manual

This manual is written for the owner and user of the BT300 HVAC Variable Speed Drive. It is designed to help you become familiar with the BT300 HVAC Variable Speed Drive and its applications.

This section covers manual organization, document conventions and symbols used in the manual, how to access help, related publications, and any other information that will help you use this manual.

Document Conventions



The following table lists conventions to help you use this manual in a quick and efficient manner.

Convention	Examples
Numbered Lists (1, 2, 3...) indicate a procedure with sequential steps.	<ol style="list-style-type: none"> 1. Turn OFF power to the field panel. 2. Turn ON power to the field panel. 3. Contact the local Siemens Industry representative.
<p>Conditions that must be completed or met before beginning a task are designated with a ►.</p> <p>Intermediate results (what will happen following the execution of a step), are designated with a ⇨.</p> <p>Results, which inform the user that a task was completed successfully, are designated with a ⇩.</p>	<p>►Composer software is properly installed.</p> <p>►A Valid license is available.</p> <ol style="list-style-type: none"> 1. Select Start > Programs > Siemens > GMS > Composer. <p>⇨The Project Management window displays.</p> <ol style="list-style-type: none"> 2. Open an existing project or create a new one. <p>⇩The project window displays.</p>
Actions that should be performed are specified in boldface font.	<p>Type F for Field panels.</p> <p>Click OK to save changes and close the dialog box.</p>
Error and system messages are displayed in Courier New font.	The message <code>Report Definition successfully renamed</code> displays in the status bar.
New terms appearing for the first time are italicized.	The field panel continuously executes a user-defined set of instructions called the <i>control program</i> .
	This symbol signifies Notes. Notes provide additional information or helpful hints.
Cross references to other information are indicated with an arrow and the page number, enclosed in brackets: [→92]	For more information on creating flowcharts, see Flowcharts [→92].
Placeholders indicate text that can vary based on your selection. Placeholders are specified by italicized letters, and enclosed with brackets [].	Type A C D H [<i>username</i>] [<i>field panel #</i>].

Safety Symbols

The following table lists the safety symbols used in this manual to draw attention to important information.

Table 1: Warning Symbols.

Symbol	Description
	DANGER or WARNING : Dangerous voltage is present. DANGER ou AVERTISSEMENT : Présence de tension dangereuse.
	WARNING or CAUTION AVERTISSEMENT ou ATTENTION
	NOTE REMARQUE

The following table describes the safety notices used in this manual to draw attention to important information.

Table 2: Warning Descriptions.

Warning Type	Description
DANGER	Serious injury, death, or severe equipment damage is imminent if a procedure or instruction is not followed as specified. Le non respect d'une procédure ou instruction peut provoquer instantanément des blessures graves, voir mortelles, ou endommager l'équipement
WARNING	Serious injury, death, or severe equipment damage could occur if a procedure or instruction is not followed as specified. Le non respect d'une procédure ou instruction peut provoquer des blessures graves voir mortelles ou endommager l'équipement.
CAUTION	Minor or moderate injury may occur if a procedure or instruction is not followed as specified. Le non respect d'une procédure ou instruction peut provoquer des blessures mineures ou modérés.
NOTICE	Equipment damage or unwanted operation may occur if a procedure or instruction is not followed as specified. Le non respect d'une procédure ou instruction peut endommager l'équipement ou entraîner un fonctionnement intempestif.
NOTE	Notes provide additional information or helpful hints. Les remarques fournissent des informations supplémentaires ou des conseils utiles.

Getting Help

For more information about BT300 products, contact your local Siemens Industry representative.

Chapter 1 - User Interfaces on Siemens BT300

This chapter presents the different user interfaces on Siemens BT300:

- Keypad
- Siemens NET
- Fieldbus

Drive Keypad

The control keypad with graphical interface is the interface between the Siemens BT300 HVAC Drive and the user. With the control keypad it is possible to control the speed of a motor, to supervise the state of the equipment and to set the variable frequency driver's parameters.

Keypad Buttons

The keypad features nine buttons used to configure and control the drive.



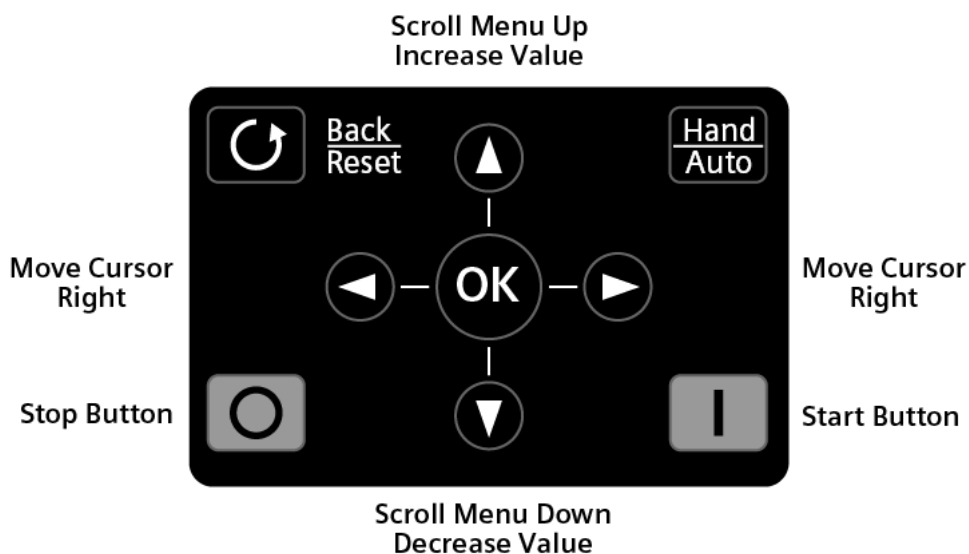

Back
Reset

Move Backward in Menu
Exit Edit Mode
Reset Faults with long Press









Enter Active Level/Item
Confirm Selection

Figure 1: Keypad Buttons.

-  This button (back/reset) allows you to move backwards in the menu, backup a step when using a wizard, exit the edit mode, or reset a fault (when held for approximately one second).
-  or  These buttons allow you to scroll up (or down) in the menu or increase (or decrease) a parameter value when editing.

BT0129R1

-  or  These buttons allow you to move the cursor left (or right) when editing a parameter value.
-  This button allows you to move to the next step when using a wizard, select an item in the menu, or select a setting for a parameter when editing.
-  This button allows you to quickly access the Control Page and to easily change between the Hand (Keypad) or Auto mode of operation. If an Electronic Bypass is present, this button provides access to the drive-off bypass functions.
-  This button allows you to start the drive in Keypad (Hand) mode of operation.
-  This button allows you to stop the drive in Keypad (Hand) mode of operation. This button can also be used as an emergency stop (unless limited by the **Keypad Stop Button** [P3.2.3]).

Keypad Display

The keypad display indicates the status of the motor and the drive and any irregularities in motor or drive functions. On the display, you can view information about the present location in the menu structure and the item displayed.

See *Chapter 4* for a comprehensive view of the menu structure.

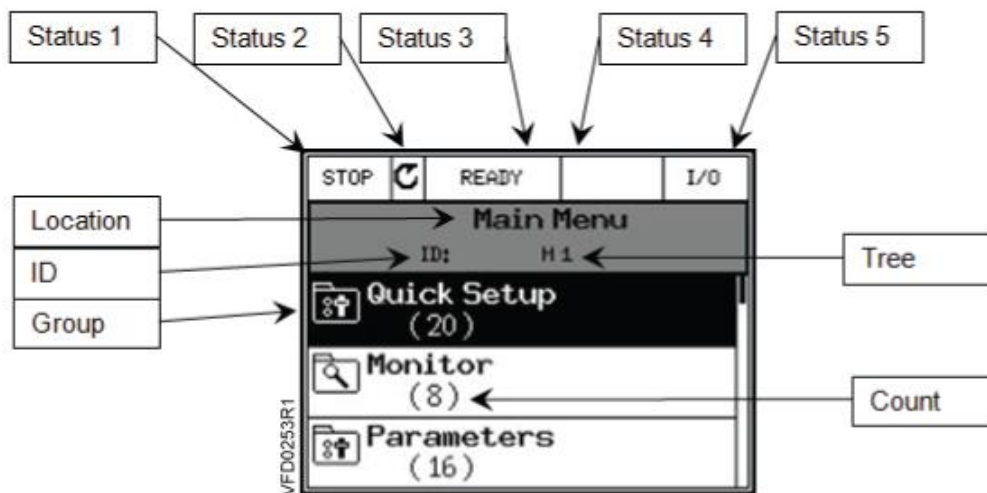

Figure 2: Keypad Display.

Several pieces of information are available on the display at any given moment. Five status fields are provided across the top of the display, as well as the location/parameter selected. Group information is also available. These fields are:





- Status 1:** Indicates the drive's run status.
- Status 2:** Indicates the drive's run direction.
- Status 3:** Indicates if the drive is **READY** to run, **NOT READY** to run, in **FAULT**, or in **BYPASS** (if **Electronic Bypass** is enabled).
- Status 4:** Indicates if the drive is in **ALARM**.
- Status 5:** Indicates the current control place, such as **I/O**, **FB**, **KEYPAD**, **PC**, or **OFF** (if **Electronic Bypass** is enabled).

- **Location:** Indicates the Menu name, Sub-menu name, or parameter name that is currently selected.
- **ID:** Indicates the parameter ID (if applicable) for the parameter selected.
- **Tree:** Indicates the menu, sub-menu, or parameter tree structure number.

**NOTE:**

This field always shows standard English digits regardless of the language selected by Language Selections (P6.1).

- **Group:** Indicates the group, sub-group, or parameter name that is in the list. The highlight represents the selected item.
- **Count:** Indicates the count of items listed in the group or sub-group.

The data on the control keypad are arranged in menus and sub-menus. Use the UP  and DOWN  arrows to move between the menus. Enter the group/item by pressing the  button and return to the previous level by pressing the Back/Reset  button.

Using the Keypad

This section covers the editing of parameter values, resetting of faults, accessing the control page, obtaining help related to parameters, and configuring the items for the Favorites menu.

Editing Values

**NOTES:**

1. Some parameters cannot be changed when the drive is in the Run state.
2. Some parameters require a power cycle to implement changes.

Change the value of a parameter by using the following procedure:

1. Locate the parameter. See *Chapter 4* for parameter details.
2. Highlight the parameter and complete one of the following:



Press the  button to enter the parameter choice menu, which contains **Edit**, **Help**, and **Add To** (or



Remove From) **Favorites**. Highlight **Edit** and press the  button a second time.

Press the  button to enter directly into the parameter editing mode.

3. Set the new value using the  or  buttons.

**NOTE:**

You can move from digit-to-digit using the  or  buttons if the value is numerical.

4. Confirm the change with the  button or ignore the change by returning to the previous level with the  button.

5. To exit a parameter, press the  button.

Resetting a Fault

When a fault has occurred, there are four ways to reset the fault:



NOTE:

Remove the external control signal before resetting the fault to prevent unintentional restart of the drive.

- If fieldbus communication is in use, command the Reset Fault object.
- If a digital input is programmed for **Fault Reset Close** (P3.5.1.9) or **Fault Reset Open** (P3.5.1.10), toggle the digital input.



NOTE:

The default setting for **Fault Reset Close** (P3.5.1.9) is **Digital Input 6** (DigIN SlotA.6).

- Press and hold the  button on the keypad for one second.
- Enter the **Diagnostics (M4)** menu, enter **Reset Faults** (P4.2) parameter, and select **Reset Faults**. See *Chapter 6* for further information on fault diagnostics.

Control Places





A *control place* is the source of control where the drive can be started and stopped. Every control place has its own parameter for selecting the frequency reference source. In **Hand**, the control place is the keypad (by default). The auto control place is determined by the setting in **Auto Control Place** (P1.15 or P3.2.1). The selected control place is displayed on the keypad in the area marked **Status 5** (see *Figure 2*).

Auto Control Place





I/O A, I/O B, and fieldbus can be used as auto control places.

- I/O A and fieldbus have the lowest priority and can be chosen with **Auto Control Place** (P3.2.1).
- I/O B can bypass the auto control place selected using a digital input. The digital input is selected with **I/O B Control Force** (P3.5.1.5).
- The keypad is always used as a control place while in Hand Control.

Selection of Hand from Auto





1. From any screen in the menu structure, press the  button.
2. Use the  or  buttons to highlight **Hand** and press the  button.
3. When **Activate** displays, press the  button to confirm.

Selecting Auto from Hand

1. From any screen in the menu structure, press the  button.
2. Use the  or  buttons to highlight **Auto** and press the  button.
3. When **Activate** displays, press the  button to confirm.

Accessing the Control Page

The Control Page enables easy operation and monitoring of the most essential values. It contains the setpoint (in hertz) and four additional pieces of information (output frequency, energy counter, motor current, and motor power) that you can change.

1. From any screen in the menu structure, press the  button.
2. Use the  or  buttons to highlight **Control Page** and press the  button.
3. When **Activate** displays, press the  button to confirm.

Help

The graphical keypad features instant help, and information displays for various items.

All parameters offer an instant help display. Select **Help** and press the  button.

Text information is also available for faults, alarms and the Start-up Wizard.

Adding an Item to Favorites

At times, you may need to refer to certain parameter values or other items. Instead of locating them one-by-one in the menu structure, you can add them to a folder called **Favorites**, where they can easily be reached.

To remove an item from **Favorites**, see Favorites (M7) [→ 170] in *Chapter 4*.

NET (Software Tool)

NET is a personal computer tool used for commissioning and maintaining the BT300 HVAC Drive. Contact your local Siemens Representative to obtain a copy of the Siemens NET Tool.

The tool includes the following features:

- Parameterization, monitoring, drive information, data logging, and so on.
- Integrated software download tool--Siemens LoadTool.
- RS-422 and Ethernet support.
- Windows 7 support.
- Multiple languages: English, Chinese, Czech, Danish, Dutch, Finnish, French, German, Italian, Polish, Portuguese, Romanian, Russian, Slovak, Spanish, Swedish, and Turkish.
- Connection can be made using the USB/RS-422 cable (Part Number BT300-CABLE) or any standard Category 5 Ethernet cable.
- USB/RS-422 drivers are automatically installed during the Siemens NET installation.
- When the connection is made, Siemens NET automatically finds the connected drive.



NOTE:

See the software's **Help** menu for more information on using Siemens NET.

Fieldbus

The BT300 HVAC Drive has both RS-485 communication and Ethernet protocols built into the core product; there are no special order requirements for obtaining the desired protocols. The RS-485 protocols are: APOGEE-P1, BACnet MS/TP, Johnson N2, and Modbus RTU. The Ethernet protocols are: BACnet IP and Modbus TCP.

The built-in RS-485 protocols are documented in section *RS-485* in Chapter 4. The built-in Ethernet protocols are documented in the *Ethernet* section in Chapter 4.

Chapter 2 - Control Board Terminal Connections

The control board terminals are located on the control module. The control module is identical for all sizes of the BT300 HVAC Drive. It contains the keypad, terminals, and the control processor of the drive.

Connect the control wiring to the BT300 control terminals per the site-specific drawings.

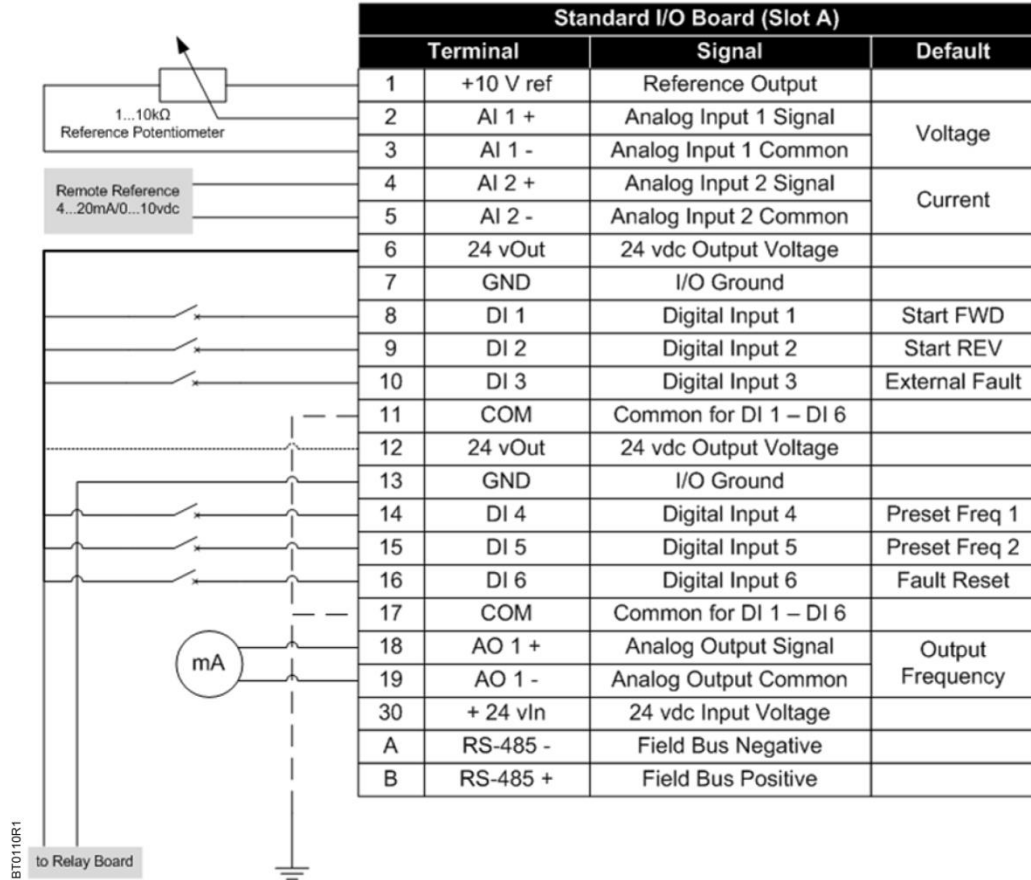

Figure 3: Slot A Terminal Connections.

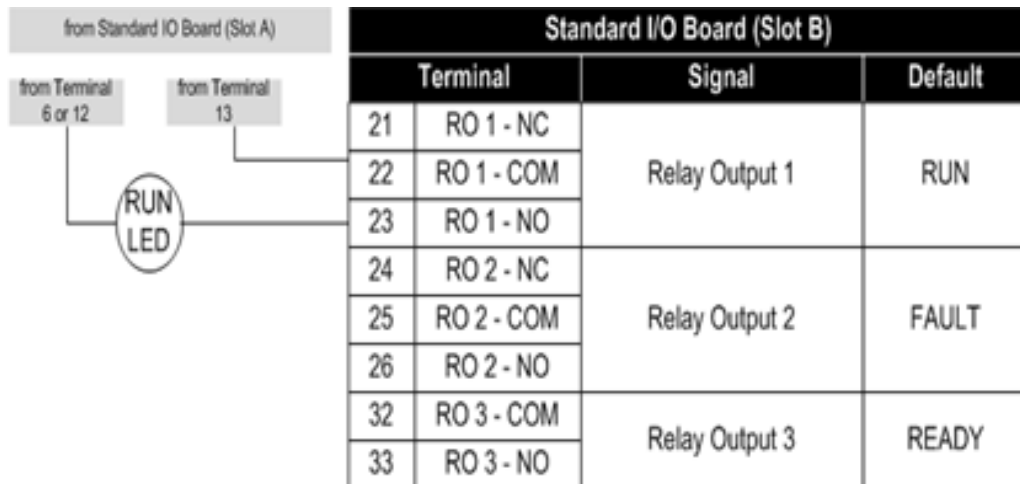

Figure 4: Slot B Terminal Connections.

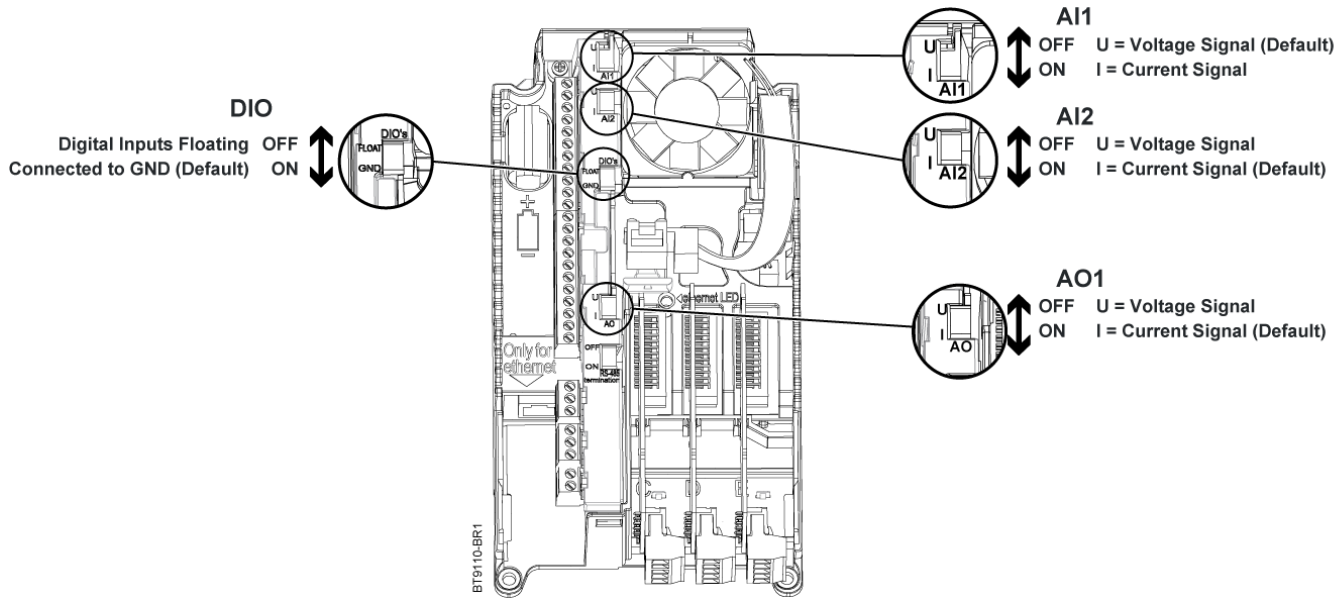

Figure 5: I/O-Related DIP Switches.

Analog Input Terminal Connections

The BT300 HVAC Drive consists of two analog inputs built on Slot A. When using analog inputs, the DIP switches must be correctly set and the analog inputs correctly configured before enabling them.

When using an analog input for speed reference, the signal is automatically scaled for **Minimum Frequency** (P3.3.1) to **Maximum Frequency** (P3.3.2) in accordance with the signal range (for example, on a 0 to 10 Vdc signal, 0V represents Minimum Frequency and 10V represents Maximum Frequency). This scaling can be modified. See the analog input parameters listed in *Chapter 3*.

Analog Input 1

By default, Analog Input 1 is configured for a 0 to 10 Vdc signal source. The wiring is shown below. See Figure 5 for the location of the AI1 DIP switch. The DIP switch is set to the **U** (voltage) position at the factory. **AI1 Signal Range** (P3.5.2.3) is used for programming the signal range of the analog input. Possible settings are 0 to 10 Vdc/0 to 20 mA or 2 to 10 Vdc/4 to 20 mA.

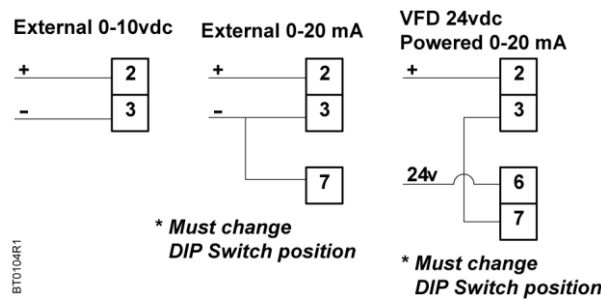

Figure 6: Analog Input 1 Terminal Connections.

Analog Input 2

By default, Analog Input 2 is configured for a 4 to 20 mA signal source. The wiring is shown below. See Figure 5 for the location of the AI2 DIP switch. The DIP switch is set to the **I** (current) position at the factory. **AI2**

Signal Range (P3.5.2.9) is used for programming the signal range of the analog input. Possible settings are 0 to 10 Vdc/0 to 20 mA or 2 to 10 Vdc/4 to 20 mA.

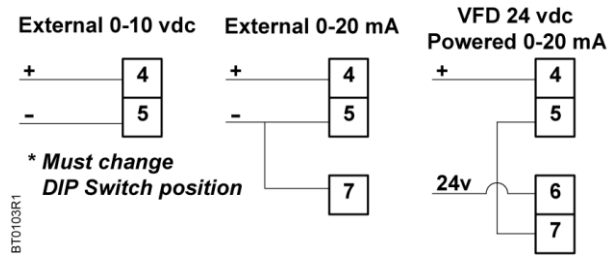

Figure 7: Analog Input 2 Terminal Connections.

Digital Input Terminal Connections

The BT300 HVAC Drive consists of six digital inputs built on Slot A. When using digital inputs, the DIP switch must be correctly set and digital inputs correctly configured before enabling them.

Digital Inputs 1 through 6

See Figure 5 for the location of the DIO DIP switch. The DIP switch is set to the GND (Grounded) position at the factory.

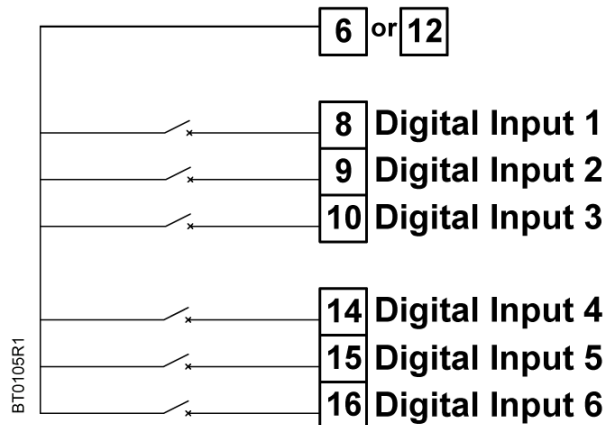

Figure 8: Digital Input Terminal Connections.

Analog Output Terminal Connections

The BT300 HVAC consists of one analog output built on Slot A. When using the analog output, the DIP switch must be correctly set and the analog output correctly configured.

Analog Output 1

By default, Analog Output 1 is configured for a 4 to 20 mA signal. The wiring is shown below. See Figure 5 for the location of the AO1 DIP switch. The DIP switch is set to the I (current) position at the factory.

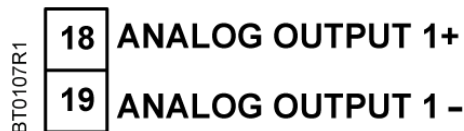

Figure 9: Analog Output 1 Terminal Connections.

Digital Output Terminal Connections

The BT300 HVAC Drive consists of three digital (relay) outputs built on Slot B. See Figure 5 for the location of the DIO DIP switch. When using the digital outputs, the DIP switch must be correctly set and digital outputs correctly configured.

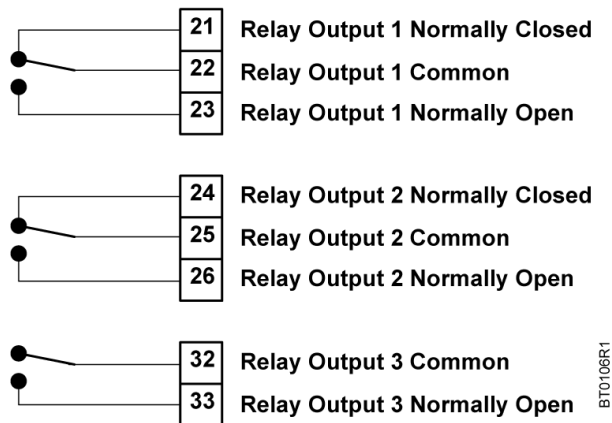

Figure 10: Digital Output Terminal Connections.

Chapter 3 - Start-up Information

Procedure and Checklist

To provide the most reliable drive available, and to avoid any extra costs related to loss or reduction of warranty coverage, a factory-certified specialist should complete the startup procedures covered in the *Startup Procedure and Checklist* (125-1006).

Commissioning Flowchart

Table 3: Commissioning Flowchart.

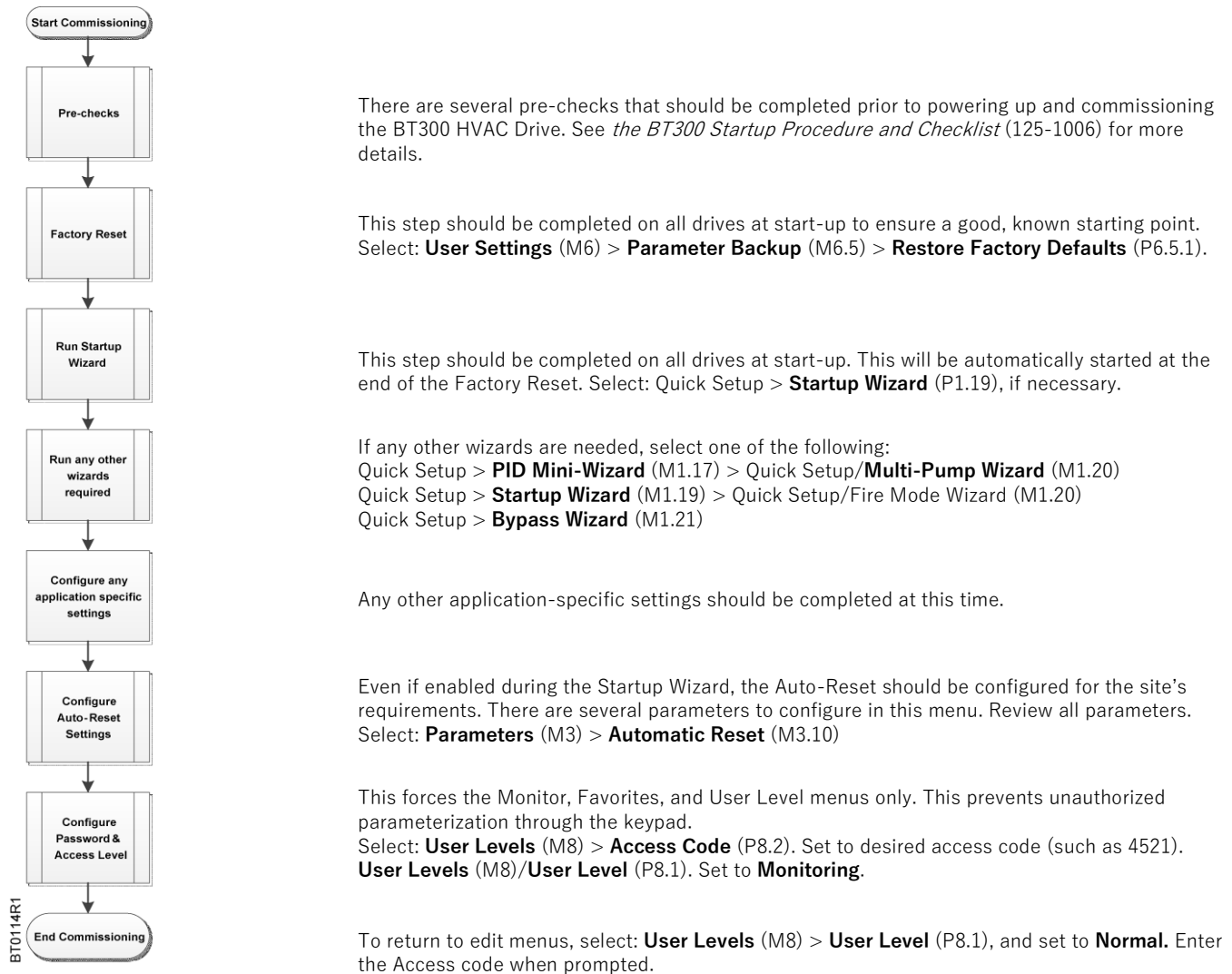

Wizards

Wizards are available in the **Quick Setup (M1)** menu. The wizards assist you with various start-up and commissioning functions. There are five wizards available in the BT300 HVAC Drive that prompt for essential information needed for the following:

- **Start-up Wizard** - Easy commissioning of the drive.
- **PID Mini-Wizard** - Proper configuration of internal PID Loop Controller 1.
- **Multi-Pump Wizard** - Proper configuration of the Multi-pump application.
- **Fire-Mode Wizard** - Proper configuration of the Fire-mode.
- **Bypass Wizard** - Proper configuration of the bypass options (if connected).

Startup Wizard (P1.19)

The Startup Wizard prompts you for the essential information needed by the drive so that it can start controlling the output as desired. Once power is connected to the BT300 HVAC Drive, the Startup Wizard should run automatically. If it is not running, it can be activated in the **Quick Setup (M1)** menu or by completing **Restore Factory Defaults** (P6.5.1)

The following steps are required to successfully complete the Startup Wizard:

Step	Parameter/Question	Settings
1	Language Selections (P6.1)	Select the icon for the language you want applied to the keypad. This varies depending upon the language package installed.
2	Daylight Saving (P5.5.5)	Select the Daylight Saving Rule 1 = Off 2 = EU 3 = US 4 = Russia
3	Time (P5.5.2)	Specify the current time of day in the following format: hh:mm:ss where h = hour, m = minute, s = seconds.
4	Year (P5.5.4)	Specify the current year in the following format: yyyy where yyyy = 4-digit year.
5	Date (P5.5.3)	Specify the current date in the following format: dd.mm where dd = 2-digit day, mm = 2-digit month.
6	Startup Wizard?	Specify if the Startup Wizard should be activated: Yes, No

If the option **Yes** is selected for Startup Wizard (recommended), you will be prompted for the following values:

Step	Parameter/Question	Settings
7	Fan or Pump (Application Type)	Pump Automatically sets the following: Accel Time 1 (P1.13) = 30 Decel Time 1 (P1.14) = 30 Start Function (P3.2.4) = Ramping Stop Function (P3.2.5) = Ramping Fan Automatically sets the following: Accel Time 1 (P1.13) = 120 Decel Time 1 (P1.14) = 120 Start Function (P3.2.4) = Flying Start Stop Function (P3.2.5) = Coast to Stop
8	Motor Nom Voltg (P3.1.1.1)	Defines nominal motor voltage from motor nameplate data.
9	Motor Nom Freq (P3.1.1.2)	Defines nominal motor frequency from motor nameplate data.
10	Motor Nom Speed (P3.1.1.3)	Defines nominal motor speed from motor nameplate data.
11	Motor Nom Currnt (P3.1.1.4)	Defines nominal motor current from motor nameplate data.
12	Motor Cos Phi (P3.1.1.5) (Power Factor)	Defines nominal motor Cos Phi (power factor) from motor nameplate data.
13	Motor Nom Power (P3.1.1.6)	Defines nominal motor power from motor nameplate data.
14	Min Frequency (P3.3.1)	Minimum allowed frequency reference.
15	Max Frequency (P3.3.2)	Maximum allowed frequency reference.
16	I/O Ctrl Ref (P3.3.3)	Selects location of frequency setpoint source when in I/O A control. In the following list of possible settings, the main setpoint is selected: 1 = Preset Freq 0 2 = Keypad Reference 3 = Fieldbus 4 = AI1 5 = AI2 6 = AI1+AI2 7 = PID 1 Reference 8 = Motor Potentiometer
17	Accel Time (P3.4.2)	Defines the time required to increase output frequency from 0 to Max Frequency (P3.3.1).
18	Decel Time (P3.4.3)	Defines the time required to decrease output frequency from Max Frequency (P3.3.1) to 0 frequency.
19	Ctrl Place Auto (P3.2.1)	Start/Stop commands are given differently depending upon the control place. This parameter defines whether the Start/Stop command is controlled by digital inputs as defined in Control Signal 1 A (P3.5.1.1) and Control Signal 2 A (P3.5.1.2) in accordance with the I/O A Start/Stop Logic (P3.2.6) or if the Start/Stop command is controlled by the Fieldbus that is in use. Settings: 0 = I/O Control (control is from the physical I/O, PID control, or time channels) 1 = Fieldbus (control is from the configured fieldbus found in Ethernet or RS-485 settings).
20	Automatic Reset (P3.10.1)	Determines if the Automatic Reset feature can be used.

Step	Parameter/Question	Settings
21	Start Function (P3.2.4)	Defines the start function of the drive. 0 = Ramping Start 1 = Flying Start
22	Stop Function (P3.2.5)	Defines the stop function of the drive. 0 = Coast to Stop 1 = Ramping Stop
23	Motor Switch (P3.1.2.2)	Prevents the drive from tripping when a motor switch is located between the drive and motor. 0 = No 1 = Yes
24	Bypass Wizard (P1.21)	Enable parameter for the Bypass Wizard. This wizard can be activated during the Startup Wizard.

The Startup Wizard is now complete.

PID Mini-Wizard (P1.17)

The PID Mini-Wizard is activated in the **Quick Setup (M1)** menu. This wizard will assist with configuring the drive for use with the PID Controller 1 in a “one-feedback/one-setpoint” mode. The control place will be I/O A and the default process unit is %.

The following steps are required to successfully complete the PID Mini-Wizard:

Step	Parameter/Question	Settings
1	Process unit selection (P3.12.1.4)	Several selections, see P3.12.1.4.

If a process unit other than % is selected, the following questions display. Otherwise, the wizard jumps directly to Step 5:

Step	Parameter/Question	Settings
2	Process Unit Min (P3.12.1.5)	Varies
3	Process Unit Max (P3.12.1.6)	Varies
4	Process Unit Decimals (P3.12.1.7)	Range: 0 to 4
5	Feedback 1 Source Selection (P3.12.3.3)	Several selections, see P3.12.3.3.

If one of the analog input signals is selected, Step 6 displays. Otherwise, the wizard jumps directly to Step 7.

Step	Parameter/Question	Settings
6	Analog Input Signal Range	0 to 10V/0 to 20 mA 2 to 10V/4 to 20 mA
7	Error Inversion (P3.12.1.8)	Reverse Acting Direct Acting
8	Setpoint Source Selection (P3.12.2.4)	Several selections, see P3.12.3.4.

If one of the analog input signals is selected, Step 9 displays. If the either of the options **Keypad SP1** or **Keypad SP2** is selected, then Step 10 displays. Otherwise, the wizard jumps directly to Step 11.

Step	Parameter/Question	Settings
9	Analog Input Signal Range	0 to 10V/0 to 20 mA 2 to 10V/4 to 20 mA
10	Keypad SP1 (P3.12.2.1) or Keypad SP2 (P3.12.2.2)	Varies
11	Sleep Function?	No Yes

If the option **Yes** is selected for Sleep Function, you will be prompted for the sleep function settings:

Step	Parameter/Question	Settings
12	Sleep Frequency Limit 1 (P3.13.2.7)	Varies
13	Sleep Delay 1 (P3.12.2.8)	Varies
14	Wake-up Level 1 (P3.12.2.9)	Varies

The PID Mini-Wizard is now complete.

Multi-Pump Wizard (P1.18)

The Multi-Pump Wizard is activated in the **Quick Setup (M1)** menu. This wizard assists with configuring the drive for use with PID Controller 1, and then asks the most important questions for setting up a multi-pump system.

The following steps are required to successfully complete the Multi-Pump Wizard:

Step	Parameter/Question	Settings
1 – 14	Same as PID Mini-Wizard	
15	Number of Motors (P3.14.1)	1 to 4
16	Interlock Function (P3.14.2)	Not Used Enabled
17	Auto-change (P3.14.4)	Disabled Enabled

If the Auto-change function is enabled, the following will display. Otherwise, the wizard jumps directly to Step 21:

Step	Parameter/Question	Settings
18	Include FC (P3.14.3)	Disabled Enabled
19	Auto-change Interval (P3.14.5)	0.0 to 3000.0 h
20	Auto-change Frequency Limit (P3.14.6)	0.0 to 60.0 Hz
21	Bandwidth (P3.14.8)	0 to 100%
22	Bandwidth Delay (P3.14.9)	0 to 3600 s

After this, the keypad displays the digital input and relay output configuration done by the application. It is recommended that these values are written down for future reference.

The Multi-Pump Wizard is now complete.

Fire Mode Wizard (P1.20)

The Fire Mode feature of the drive is designed to place the drive in a mode that ignores all commands from the keypad, fieldbuses, and the personal computer tool. In addition, the drive will ignore all alarms and faults of the drive and continue providing frequency to the attached motor. This is designed for instances when the destruction of equipment is better than loss of life. The Fire Mode feature can be operated so that the PID loop is still in control of the attached motor. The Fire Mode Wizard allows for easy commissioning of the Fire Mode function.

The Fire Mode Wizard is activated in the **Quick Setup (M1)** menu. The wizard assists with configuring the drive for use with the Fire Mode feature.



NOTE:

The warranty is void if the Fire Mode function is activated. Test Mode can be used to test the Fire Mode function without voiding the warranty. Read important information about the password and warranty issues in Chapter 4 before you proceed.

Test Mode can be used to test the Fire Mode function without voiding the warranty.

The Fire Mode Wizard can be initiated by choosing **Activate** for **Fire Mode Wizard (P1.20)** in the **Quick Setup (M1)** Menu.

The following steps are required to successfully complete the Fire-Mode Wizard:

Step	Parameter/Question	Settings
1	Fire Mode Frequency Source (P3.16.5)	Several selections; see P3.16.5.

If **Fire Mode Frequency** is selected, the following will display. Otherwise, the wizard jumps directly to Step 3:

Step	Parameter/Question	Settings
2	Fire Mode Frequency (P3.16.4)	Range: 0 to Maximum Frequency (P1.9)
3	Signal Activation?	Open Contact Closed Contact
4	Fire Mode Activation Open (P3.16.2) Or Fire Mode Activation Close (P3.16.3)	Choose the digital input to activate Fire Mode.
5	Fire Mode Reverse (P3.16.6)	Choose the digital input to activate the reverse command in Fire Mode. DigIN Slot0.1 = FORWARD DigIN Slot0.2 = REVERSE
6	Fire Mode Password (P3.16.1)	Choose the password to enable the Fire Mode Function.: 1234 = Test Mode 1002 = Enable Fire Mode

The Fire Mode Wizard is now complete.

Bypass Wizard (P1.21)

The Bypass Wizard is activated in the **Quick Setup (M1)** menu. The wizard assists with configuring the drive for use with the Conventional or Electronic Bypass options. If the **Electronic Bypass** option is selected, additional features can be enabled, if desired. The standard I/O is re-mapped for use with the Electronic Bypass option. Additional parameters are available when the **Electronic Bypass** option is enabled.

The following steps are required to successfully complete the Bypass Wizard:

Step	Parameter/Question	Settings
1	Select the Bypass (P3.17.4) mode	Electronic Conventional Disabled

If **Conventional** is selected, the following changes occur automatically, the wizard completes, and the message: *Bypass Wizard is now complete. Press OK to continue.* displays.

- **Control Signal 2 A** (P3.5.1.2) is set to **DigIN Slot0.1** to disable the reverse command on Digital Input 2.
- **Run Interlock 2** (P3.5.1.13) is set to **DigIN SlotA.2** to enable the run interlock on Digital Input 2. The status of the Output Contactor (M2) is factory-wired to digital input 2.
- **Preset Freq Sel0** (P3.5.1.15) is set to **DigIN Slot0.1** to disable the Preset Frequency Selection **0** on Digital Input 4.
- **Overload** (P3.5.1.53) is set to **DigIN SlotA.5** to enable the overload on Digital Input 5. The status of the Overload is factory-wired to Digital Input 5.

If **Electronic** is selected, the following change occurs automatically:

Overload (P3.5.1.53) is set to **DigIN SlotA.5** to enable the overload on Digital Input 5. The status of the Overload is factory-wired to Digital Input 5.

The wizard continues with the following steps:

Step	Parameter/Question	Settings
2	Bypass Delay (P3.18.1) Time	Defines the amount of time between the unit being placed into Bypass mode and the M1 contactor closing. Range: 1 to 30 s
3	Essential Services* (P3.18.5)	Enabled Disabled

If **Enabled** is selected for Essential Services, Step 4 displays. Otherwise, the wizard jumps directly to Step 5.

Step	Parameter/Question	Settings
4	Essential Services Activation (P3.5.1.52)	DigIN SlotA.6
5	Remote Bypass* (P3.18.6)	Enabled Disabled

If **Enabled** is selected for Remote Bypass, Step 6 displays. Otherwise, the wizard jumps directly to Step 7.

Step	Parameter/Question	Settings
6	Command Source (P3.5.1.1)	Fieldbus CTRL I/O Control
7	Interlock* (P3.2.11)	Enabled Disabled

If **Enabled** is selected for Interlock, Step 8 displays. Otherwise, the wizard jumps directly to Step 9.

Step	Parameter/Question	Settings
8	Interlock Delay (P3.2.12)	Range: 0 to 120 s
9	Auto Bypass* (P3.18.2)	Enabled Disabled

If **Enabled** is selected for Auto Bypass, Step 10 displays. Otherwise, the wizard jumps directly to Step 11.

Step	Parameter/Question	Settings
10	Auto Bypass Delay (P3.18.4)	Range: 0 to 30 s
11	Fault Selection (P3.18.3)	Select faults to enable auto Bypass: Any Fault Undervoltage Overvoltage Overcurrent AI Low Unit Temperature Motor Overtemp External Fault Underload Fault

* Feature of the Electronic Bypass Option. For more details, see *BT300 Bypass Operator's Manual* (DPD01391)
The Bypass Wizard is now complete. The following message displays: Bypass Wizard is now complete. Press OK to continue.

If **Disabled** is selected, no changes occur and the wizard completes The following message displays: Bypass Wizard is now complete. Press OK to continue.

For more information on the bypass options, see the *BT300 Variable Frequency Drive Bypass Installation Instructions* (DPD01375) and the *BT300 Variable Frequency Drive Bypass Operator's Manual* (DPD01391).

Chapter 4 - Parameters and Menu Structure

All information and parameters are organized in a menu structure:

Quick Setup (M1) <i>All basic parameters required to quickly setup the BT300 VFD for operation and all available wizards.</i>	P1.17 PID Mini-Wizard	Diagnostics (M4) <i>Diagnostics information such as active faults, fault history and counters.</i>	M4.1 Active Faults	
	P1.18 Multi-Pump Wizard		M4.2 Reset Faults	
	P1.19 Startup Wizard		M4.3 Fault History	
	P1.20 Fire Mode Wizard		M4.4 Total Counters	
	P1.21 Bypass Wizard		M4.5 Trip Counters	
Monitor (M2) <i>Access to the Multi-monitor display and parameters used for monitoring.</i>	M2.1 Multimonitor	I/O and Hardware (M5) <i>Parameters for status of I/O, real time clock, keypad, and fieldbus configuration.</i>	M4.6 Software Info	
	M2.2 Basic		M5.1 Basic IO	
	M2.3 Timer Functions		M5.2 Slot C	
	M2.4 PID Controller 1		M5.3 Slot D	
	M2.5 PID Controller 2		M5.4 Slot E	
	M2.6 Multi-Pump		M5.5 Real Time Clock	
	M2.8 Fieldbus Data		M5.6 Power Unit Settings	
Parameters (M3) <i>Parameters used for basic and advanced configuration requirements.</i>	M2.9 Temp. Inputs	User Settings (M6) <i>User information such as keypad language selection, parameter backup/restore, and drive name.</i>	M5.7 Keypad	
	M3.1 Motor Settings		M5.8 RS-485	
	M3.2 Start/Stop Setup		M5.8.1 Common Settings	
	M3.3 References		M5.8.3 BACnet MSTP ¹	
	M3.4 Ramps and Brakes		M5.8.3 Modbus RTU ¹	
	M3.5 I/O Config		M5.8.3 N2 ¹	
	M3.5.1 Digital Inputs		M5.8.3 P1 ¹	
	M3.5.2 Analog Inputs		M5.9 Ethernet	
	M3.5.3 Digital Outputs		M5.9.1 Common Settings	
	M3.5.4 Analog Outputs		M5.9.2 Modbus TCP	
	M3.6 Fieldbus DataMap		M5.9.3 BACnet IP	
	M3.7 Prohibit Freq		M6.1 Language Selection	
	M3.8 Limit Superv		M6.5 Parameter Backup	
	M3.9 Protections		M6.6 Parameter Compare	
	M3.10 Automatic Reset		M6.7 Drive Name	
	M3.11 Timer Function		Favorites (M7) <i>List of user-defined parameter list.</i>	
	M3.12 PID Controller 1			
	M3.13 PID Controller 2			
M3.14 Multi-Pump	User Levels (M8) <i>Restricts the visibility of parameters</i>	P8.1 User Level		
M3.16 Fire Mode		P8.2 Access Code		
M3.17 Appl. Settings				
M3.18 Bypass ²	¹ Displayed based on value of Protocol (P5.8.1.1)			
	² Displayed based on value of Bypass (P3.17.4)			

Quick Setup (M1)

The Quick Setup parameter group is a collection of parameters that are the most commonly used during installation and commissioning. They are collected in the first parameter group so that they can be found quickly and easily. However, they can be also be reached and edited in the actual parameter groups. Changing a parameter value in the Quick Setup group also changes the value of this parameter in its actual group.

The Quick Setup parameters are presented in the following table:

Table 4: Quick Setup Parameters.

Structure	Parameter	Unit	ID	Description
P1.1	Motor Nom Voltg	V	110	Defines nominal motor voltage from motor nameplate data. Also see <i>Menu Structure P3.1.1.1</i> .
P1.2	Motor Nom Freq	Hz	111	Defines nominal motor frequency from motor nameplate data. Also see <i>Menu Structure P3.1.1.2</i> .
P1.3	Motor Nom Speed	rpm	112	Defines nominal motor speed from motor nameplate data. Also see <i>Menu Structure P3.1.1.3</i> .
P1.4	Motor Nom Currnt	A	113	Defines nominal motor current from motor nameplate data. Also see <i>Menu Structure P3.1.1.4</i> .
P1.5	Motor Cos Phi		120	Defines nominal motor Cos Phi (power factor) from motor nameplate data. Also see <i>Menu Structure P3.1.1.5</i> .
P1.6	Motor Nom Power	hp	116	Defines nominal motor power from motor nameplate data. Also see <i>Menu Structure P3.1.1.6</i> .
P1.7	Current Limit	A	107	Defines maximum current limit for motor. Suggested to use Motor Nominal Current (P1.4) multiplied by motor service factor from motor nameplate data. Also see <i>Menu Structure P3.1.1.7</i> .
P1.8	Min Frequency	Hz	101	Sets minimum motor frequency at which motor will run irrespective of frequency setpoint. Also see <i>Menu Structure P3.3.1</i> .
P1.9	Max Frequency	Hz	102	Sets maximum motor frequency at which motor will run irrespective of frequency setpoint. Also see <i>Menu Structure P3.3.2</i> .
P1.10	I/O A Ctrl Ref		117	Selects location of frequency setpoint source when in I/O A control. In the following list of possible settings, the main setpoint is selected: 1 = Preset Freq 0 2 = Keypad Reference 3 = Fieldbus 4 = AI1 5 = AI2 6 = AI1+AI2 7 = PID 1 Reference 8 = Motor Potentiometer Also see <i>Menu Structure P3.3.3</i> .
P1.11	Preset Freq 1	Hz	105	Used according to state of digital input defined for Preset Frequency Selection 1 (P3.5.1.16). Decoding mode chosen with Preset Frequency Mode (P3.3.10). Also see <i>Menu Structure P3.3.12</i> .
P1.12	Preset Freq 2	Hz	106	Used according to state of digital inputs Preset Frequency Selection 2 (P3.5.1.17). Decoding mode chosen with Preset Frequency Mode (P3.3.10). Also see <i>Menu Structure P3.3.13</i> .
P1.13	Accel Time 1	s	103	Time allowed for motor to accelerate from a standstill (0) up to Maximum Frequency (P1.9). This parameter can also be found in Menu Structure P3.4.2

Structure	Parameter	Unit	ID	Description
P1.14	Decel Time 1	s	104	Time allowed for motor to decelerate from Maximum Frequency (P1.9) to a standstill (0). Also see <i>Menu Structure P3.4.3</i> .
P1.15	Ctrl. Place Auto		172	Start/Stop commands are given differently depending upon the control place. This parameter defines whether the Start/Stop command is controlled by digital inputs as defined in Control Signal 1 A (P3.5.1.1) and Control Signal 2 A (P3.5.1.2) in accordance with the I/O A Start/Stop Logic (P3.2.6) or if the Start/Stop command is controlled by the Fieldbus that is in use. Settings: 0 = I/O Control (control is from the physical I/O, PID control, or time channels) 1 = Fieldbus (control is from the configured fieldbus found in Ethernet or RS-485 settings) Also see <i>Menu Structure P3.2.1</i> .
P1.16	Automatic Reset		731	Enable parameter for the Automatic Reset function of the drive. This feature is configured in the Parameters (M3) ... Automatic Reset (M3.10) menu. Also see <i>Menu Structure P3.10.1</i> .
P1.17	PID Mini-Wizard		1803	Enable parameter for the PID Mini-Wizard. This wizard assists with the configuration of the PID Controller 1 using a single feedback and single setpoint.
P1.18	MultiPump Wizard			Enable parameter for the Multi-Pump Wizard. This wizard assists with the configuration of the Multi-Pump function of the drive. The PID Mini Wizard will precede this wizard.
P1.19	Startup Wizard		1171	Enable parameter for the Startup Wizard. This wizard assist with the essential information required for drive operation. This wizard is automatically enabled after Restore Factory Defaults (P6.5.1) is activated.
P1.20	Fire Mode Wizard		1672	Enable parameter for the Fire Mode Wizard.
P1.21	Bypass Wizard		1823	Enable parameter for the Bypass Wizard. This wizard can be activated during the Startup Wizard.





Monitor Menu (M2)

The Siemens BT300 HVAC Drive allows you to monitor actual values, parameters, and signals as well as status and measurements. Some of the monitored values are customizable.

Table 5: Monitor Menu.

Menu and Parameter Group	Description
Multimonitor (M2.1)	Display of 9 monitored values.
Basic (M2.2)	Display of basic drive monitoring parameters.
Timer Functions (M2.3)	Display of timer function specific monitoring parameters.
PID Controller 1 (M2.4)	Display of PID Controller 1 specific monitoring parameters.
PID Controller 2 (M2.5)	Display of PID Controller 2 specific monitoring parameters.
Multi-Pump (M2.6)	Display of Multi-Pump specific monitoring parameters.
Fieldbus Data (M2.8)	Display of Mapped Fieldbus Data monitoring parameters.
Temp. Inputs (M2.9)	Display of connected temperature inputs.

Multimonitor (M2.1)

On the Multi-Monitor page, you can collect nine values to monitor. The display fields can be changed by selecting the display field to be changed with the  and  arrow buttons, and then pressing the  button. Scroll through the list of items until the desired value to be monitored is highlighted. Items with a  checkmark are already actively displayed in the multimonitor display. With an item chosen, press the  button again to add to the display field.

Basic (M2.2)

The basic monitoring values are the actual values of selected parameters and signals as well as statuses and measurements. Different applications may have different statuses and different numbers of monitoring values.



NOTE:

Only Standard I/O board statuses are available in the Monitor menu. Statuses for all I/O board signals can be found as raw data in the I/O and Hardware (M5) menu.

The basic monitoring values are presented in the following table:

Table 6: Monitoring Menu Items.

Structure	Parameter	Unit	ID	Description
M2.2.1	Output Frequency	Hz	1	Displays the actual output frequency.
M2.2.2	FreqReference	Hz	25	Displays the actual frequency reference (setpoint).
M2.2.3	Motor Speed	rpm	2	Displays the actual motor speed.
M2.2.4	Motor Current	A	3	Displays the actual motor current.
M2.2.5	Motor Torque	%	4	Displays the calculated motor torque.
M2.2.7	Motor Power	%	5	Total power consumption of the drive in %
M2.2.8	Motor Power	hp	73	Total power consumption of the drive in kW or hp
M2.2.9	Motor Voltage	V	6	Voltage feed to the motor
M2.2.10	DC-Link Voltage	V	7	Voltage available on the DC Link
M2.2.11	Unit Temperature	°F	8	Heat sink temperature
M2.2.12	MotorTemperature	%	9	Calculated motor temperature
M2.2.13	Analog Input 1	%	59	Signal of used range in %
M2.2.14	Analog Input 2	%	60	Signal of used range in %
M2.2.15	Analog Output 1	%	81	Signal of used range in %
M2.2.16	Motor PreHeat		1228	0 = Off 1 = Heating (feeding DC current)

Structure	Parameter	Unit	ID	Description
M2.2.17	DriveStatusWord		43	Bit coded status of the drive B1 = Ready B2 = Run B3 = Fault B6 = Run Enable B7 = Alarm Active B10 = DC Current (in stop) B11 = DC Brake Active B12 = Run Request B13 = Motor Regulator Active
M2.2.18	Last ActiveFault		37	Fault code of last activated fault that has not been reset. <i>See Fault Codes.</i>
M2.2.19	FireMode Status		1597	0 = Disabled 1 = Enabled 2 = Activated (Enabled & DI) 3 = Test Mode
M2.2.20	DIN StatusWord1		56	B0 = SlotA.1...B5 = SlotA.6 B6 = SlotB.1...B11 = SlotB.6 B12 = SlotC.1...B15 = SlotC.4
M2.2.21	DIN StatusWord2		57	B0 = SlotC.5...B1 = SlotC.6 B2 = SlotD.1...B7 = SlotD.6 B8 = SlotE.1...B13 = SlotE.4
M2.2.22	MotCurrent1Deci.		45	Motor current monitor value with fixed number of decimals and less filtering. For example, can be used for fieldbus purpose to always get the right value regardless of frame size, or monitoring when less filtering time is needed for motor current.
M2.2.23	Appl.StatusWord1		89	Bit coded application status word 1 B0 = Interlock1 B1 = Interlock2 B5 = I/O A Control Active B6 = I/O B Control Active B7 = Fieldbus Control Active B8 = Hand Control Active B9 = PC Control Active B10 = Preset Freq Active B12 = FireMode Active B13 = PreHeat Active
M2.2.24	Appl.StatusWord2		90	Bit coded application status word 2 B0 = Acc/Dec Prohibited B1 = MotorSwitch Active
M2.2.25	kWhTripCounter Low		1054	Energy counter with kWh output (low word)
M2.2.26	kWhTripCounter High		1067	# of times energy counter has spun around (high word)
M2.2.27	Appl.StatusWord3		1851	Bit coded application status word 3
M2.2.28	Safety StatusWord		1852	Bit coded Safety Status Word
M2.2.29	Bypass Runtime	h	1850	Bypass Running Hours

Timer functions monitoring (M2.3)

The timer functions monitoring values and the actual values of the timer functions and the real time clock. See *Timer Functions (M3.11)*.

Table 7: Monitoring of Timer Functions.

Structure	Parameter	Unit	ID	Description
M2.3.1	TC 1, TC 2, TC 3		1441	Status of the three time channels
M2.3.2	Interval 1		1442	Status of timer interval
M2.3.3	Interval 2		1443	Status of timer interval
M2.3.4	Interval 3		1444	Status of timer interval
M2.3.5	Interval 4		1445	Status of timer interval
M2.3.6	Interval 5		1446	Status of timer interval
M2.3.7	Timer 1	s	1447	Remaining time on timer (if active)
M2.3.8	Timer 2	s	1448	Remaining time on timer (if active)
M2.3.9	Timer 3	s	1449	Remaining time on timer (if active)
M2.3.10	Real Time Clock		1450	Current Time of Day

PID Controller 1 Monitoring (M2.4)

The PID Controller 1 monitoring values are the actual values of the first PID controller, which is used to control the speed of the motor that is physically connected to the drive's output. See *PID Controller 1 (M3.12)*.

The PID Controller 1 monitoring values are presented in the following table:

Table 8: PID1-Controller Value Monitoring.

Structure	Parameter	Unit	ID	Description
M2.4.1	PID1 Setpoint	Varies	20	Setpoint for the PID controller for the attached motor
M2.4.2	PID1 Feedback	Varies	21	Feedback for the PID controller for the attached motor
M2.4.3	PID1 Error	Varies	22	Error value of the PID controller for the attached motor
M2.4.4	PID1 Output	%	23	Output of the PID controller for the attached motor
M2.4.5	PID1 Status		24	0 = Stopped 1 = Running 3 = Sleep Mode 4 = In dead band

PID Controller 2 Monitoring (M2.5)

The PID Controller 2 monitoring values are the actual values of the second PID controller, which is used for external devices that require PID loop control. See *PID Controller 2 (M3.13)*.

The PID Controller 2 monitoring values are presented in the following table:

Table 9: PID2-Controller Value Monitoring.

Structure	Parameter	Unit	ID	Description
M2.5.1	PID2 Setpoint	Varies	83	Setpoint for the PID controller for the external device (AO)
M2.5.2	PID2 Feedback	Varies	84	Feedback for the PID controller for the external device (AO)
M2.5.3	PID2 Error	Varies	85	Error value of the PID controller for the external device (AO)
M2.5.4	PID2 Output	%	86	Output of the PID controller for the external device (AO)
M2.5.5	PID2 Status		87	0 = Stopped 1 = Running 4 = In dead band

Multi-pump monitoring (M2.6)

The Multi-Pump monitoring values are the actual values related to the use of several drives/motors. See *Multi-Pump (M3.14)*.

The Multi-Pump monitoring values are presented in the following table:

Table 10: Multi-Pump Monitoring.

Structure	Parameter	Unit	ID	Description
M2.6.1	Motors Running		30	The number of motors running at the moment when Multi-Pump functionality is used.
M2.6.2	Autochange		1114	If an autochange is requested, <i>requested</i> means that the autochange time has elapsed and the drive is waiting until the rest of the autochange criteria is fulfilled. For example, output frequency of controlled drive and number of running motors.

Fieldbus data monitoring (M2.8)

The Fieldbus Data monitoring values are shown for debugging purposes. See *Fieldbus Data Mapping (M3.6)*.

The Fieldbus Data monitoring values are presented in the following table:

Table 11: Fieldbus Data Monitoring.

Structure	Parameter	Unit	ID	Description
M2.8.1	FB Control Word		874	Fieldbus control word used by application in bypass mode/format. Depending on the fieldbus type or profile the data might be modified before sent to the application.
M2.8.2	FB Speed Reference	Hz	875	Speed reference scaled between minimum and maximum frequency at the moment it was received to the application. Minimum and maximum frequency might have been changed after the reference was received without affecting the reference.
M2.8.3	FB Data In 1		876	Raw value of process data in 32-bit signed format.
M2.8.4	FB Data In 2		877	Raw value of process data in 32-bit signed format.
M2.8.5	FB Data In 3		878	Raw value of process data in 32-bit signed format.
M2.8.6	FB Data In 4		879	Raw value of process data in 32-bit signed format.
M2.8.7	FB Data In 5		880	Raw value of process data in 32-bit signed format.
M2.8.8	FB Data In 6		881	Raw value of process data in 32-bit signed format.
M2.8.9	FB Data In 7		882	Raw value of process data in 32-bit signed format.
M2.8.10	FB Data In 8		883	Raw value of process data in 32-bit signed format.
M2.8.11	FB Status Word		864	Fieldbus status word sent by application in bypass mode/format. Depending on the fieldbus type or profile the data might be modified before sent to the fieldbus.
M2.8.12	FB Speed Actual	%	865	Actual speed in %. 0 and 100% corresponds to minimum and maximum frequency respectively. This is continuously updated depending on the momentary min and max frequency and output frequency.
M2.8.13	FB Data Out 1		866	Raw value of process data out 32-bit signed format.
M2.8.14	FB Data Out 2		867	Raw value of process data out 32-bit signed format.
M2.8.15	FB Data Out 3		868	Raw value of process data out 32-bit signed format.
M2.8.16	FB Data Out 4		869	Raw value of process data out 32-bit signed format.

Structure	Parameter	Unit	ID	Description
M2.8.17	FB Data Out 5		870	Raw value of process data out 32-bit signed format.
M2.8.18	FB Data Out 6		871	Raw value of process data out 32-bit signed format.
M2.8.19	FB Data Out 7		872	Raw value of process data out 32-bit signed format.
M2.8.20	FB Data Out 8		873	Raw value of process data out 32-bit signed format.

Temperature inputs monitoring (M2.9)

The Temperature Inputs monitoring values are the actual values of the temperature inputs connected using slot C, D, or E. If no sensor is available, the monitoring values do not exist.

The Temperature Inputs monitoring values are presented in the following table:

Table 12: Temperature Inputs Monitoring.

Structure	Parameter	Unit	ID	Description
M2.9.1	Temp Input 1	°F	50	Measured value of temperature input 1.
M2.9.2	Temp Input 2	°F	51	Measured value of temperature input 2.
M2.9.3	Temp Input 3	°F	52	Measured value of temperature input 3.

Parameters (M3)

The Parameters group is a collection of parameters that are used during installation and commissioning. The parameters group is used for configuration of the application in better detail than the Startup Wizard alone.

The parameters menu and application contain the following parameter groups:

Table 13: Parameter Groups.

Menu and Parameter group	Description
Motor Settings (M3.1)	Basic and advanced motor settings.
Start/Stop Setup (M3.2)	Start and stop functions.
References (M3.3)	Frequency references setup.
Ramps and Brakes (M3.4)	Acceleration and deceleration setup.
I/O Config (M3.5)	Input/Output (I/O) configuration.
Fieldbus DataMap (M3.6)	Fieldbus data out setup.
Prohibited Freq (3.7)	Prohibited frequencies setup.
Limit Superv (M3.8)	Programmable limit controllers.
Protections (M3.9)	Protections configuration.
Automatic Reset (M3.10)	Automatic reset after fault setup.
Timer Functions (M3.11)	Setup of time of day operation based on real time clock.
PID Controller 1 (M3.12)	Configuration of PID Controller 1. Used for motor control or external usage.
PID Controller 2 (M3.13)	Configuration of PID Controller 2. Used for external usage.
Multi-Pump (M3.14)	Configuration for multi-pump usage.
Fire Mode (M3.16)	Configuration for fire mode usage.
Appl. Settings (M3.17)	Parameters for regional settings and application.
ByPass (M3.18)	Parameters for Electronic Bypass option (when used).

Motor Settings (M3.1)

This structure contains basic (such as motor nameplate data) and advanced (such as pre-heat function) motor settings.

Basic Settings (M3.1.1)

Table 14: Basic Motor Settings.

Structure	Parameter	Unit	Min	Max	Default	ID	Description
P3.1.1.1	Motor Nom Voltg	V	Varies	Varies	Varies	110	Defines nominal motor voltage from motor nameplate data. Also see <i>Menu Structure P1.1</i> .
P3.1.1.2	Motor Nom Freq	Hz	8	320	60	111	Defines nominal motor frequency from motor nameplate data. Also see <i>Menu Structure P1.2</i> .
P3.1.1.3	Motor Nom Speed	rpm	24	19200	Varies	112	Defines nominal motor speed from motor nameplate data. Also see <i>Menu Structure P1.3</i> .
P3.1.1.4	Motor Nom Currnt	A	Varies	Varies	Varies	113	Defines nominal motor current from motor nameplate data. Also see <i>Menu Structure P1.4</i> .
P3.1.1.5	Motor Cos Phi		0.3	1	Varies	120	Defines nominal motor Cos Phi (power factor) from motor nameplate data. Also see <i>Menu Structure P1.5</i> .
P3.1.1.6	Motor Nom Power	hp	Varies	Varies	Varies	116	Defines nominal motor power from motor nameplate data. Also see <i>Menu Structure P1.6</i> .
P3.1.1.7	Current Limit	A	Varies	Varies	Varies	107	Defines maximum current limit for motor. Suggested to use Motor Nominal Current (P3.1.1.4) multiplied by motor service factor from motor nameplate data. Also see <i>Menu Structure P1.7</i> .
P3.1.1.8	Motor Type		IM	PMM	IM	650	Selection of the motor type as follows: 0 = IM = Asynchronous Induction Motor 1 = PMM = PM Synchronous Motor

Motor Control Settings (M3.1.2)

Table 15: Motor Control Settings.

Structure	Parameter	Unit	Min	Max	Default	ID	Description
P3.1.2.1	Switching Freq	kHz	1.5	Varies	Varies	601	Motor noise can be minimized using a high switching frequency. Increasing the switching frequency reduces the capacity of the drive. It is recommended to use a lower frequency when the motor cable is long in order to minimize capacitive currents in the cable.
P3.1.2.2	Motor Switch		No	Yes	No	653	Prevents the drive from tripping when a motor switch is located between the drive and motor. 0 = No 1 = Yes
P3.1.2.4	Zero Freq Voltg	%	0	40	Varies	606	Defines the zero frequency voltage of the U/f curve.
P3.1.2.5	Preheat Function		Not Used	Temp Limit	Not Used	1225	Defines the use of the PreHeat Function (P3.1.2.5). 0 = Not Used 1 = Always in Stop State 2 = Controlled by Digital Input 3 = Temp Limit (based on Heat Sink)
P3.1.2.6	Preheat TempLimit	°F	-20	80	0	1226	Defines the temperature the heat sink falls below for pre-heating the motor and drive when PreHeat Function (P3.1.2.5) is set to Temp Limit .
P3.1.2.7	Preheat Current	A	0	.5*IL	Varies	1227	Defines the DC current to be use for pre-heating the motor and drive when PreHeat Function (P3.1.2.5) is set to Stop State .
P3.1.2.9	U/f Ratio Select		Linear	Squared	Varies	108	Type of U/F curve between zero frequency and the field weakening point. 0 = Linear 1 = Squared
P3.1.2.15	Over Volt Contr		Disabled	Enabled	Enabled	607	Enable parameter for the over voltage controller. When enabled, the drive acceleration and speed can be modified by the controller to prevent the drive from tripping.

Structure	Parameter	Unit	Min	Max	Default	ID	Description
P3.1.2.16	Under Volt Contr		Disabled	Enabled	Enabled	608	Enable parameter for the over voltage controller. When enabled, the drive acceleration and speed can be modified by the controller to prevent the drive from tripping.
P3.1.2.17	StatorVoltAdjust	%	50	150	100	659	Parameter for adjusting stator voltage in permanent magnet motors.
P3.1.2.18	Energy Optimization		Disabled	Enabled	Disabled	666	Enable parameter to have the drive search for the minimum motor current in order to save energy and to lower the motor noise.
P3.1.2.19	Flying Start Options		Both Directions	FreqRefDirection	Both Directions	1590	0 = Shaft direction is searched in both directions. 1 = Shaft direction is searched in setpoint direction only.

U/f ratio selection (P3.1.2.9)

Table 16: Ratio Selections.

Selection Number	Selection Name	Description
0	Linear	The voltage of the motor changes linearly as a function of output frequency from zero frequency voltage (P3.1.2.4) to the field weakening point (FWP) voltage at FWP frequency. This default setting should be used if there is no special need for another setting.
1	Squared	The voltage of the motor changes from zero point voltage (P3.1.2.4) following a squared curve form from zero to the field weakening point. The motor runs under-magnetized below the field weakening point and produces less torque. Squared U/f ratio can be used in applications where torque demand is proportional to the square of the speed (for example, in centrifugal fans and pumps).

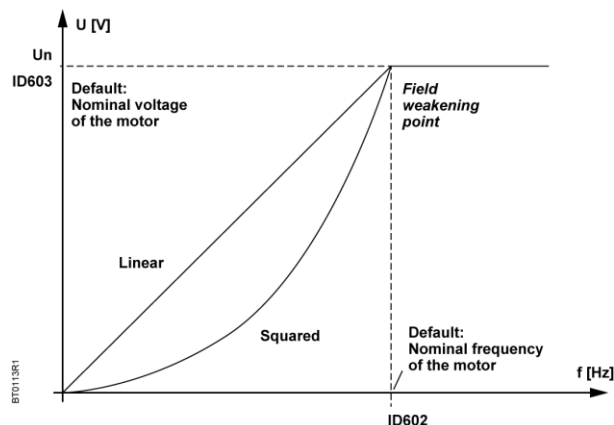

Figure 11: Linear and Squared Change of Motor Voltage.

Over-voltage controller (P3.1.2.15) and Under-voltage controller (P3.1.2.16)

These parameters allow the under-/overvoltage controllers to be switched out of operation. This may be useful, for example, if the mains supply voltage varies more than -15% to +10% and the application will not tolerate this over-/under-voltage. In this case, the regulator controls the output frequency taking the supply fluctuations into account. Over-voltage and Under-voltage controllers are enabled by default.

Start/Stop setup (M3.2)

The start/stop commands are given from different locations depending on the selected control place.

Auto Control Place I/O A: Start, stop, and reverse commands are controlled by two digital inputs chosen with **Control Signal 1 A** (P3.5.1.1) and **Control Signal 2 A** (P3.5.1.2). The functionality/logic for these inputs is selected with **I/O A Start/Stop Logic** (P3.2.6). The **I/O B Control Force** (P3.5.1.5) will determine when the Auto Control Place I/O B is in use.

Auto Control Place I/O B: Start, stop, and reverse commands are controlled by two digital inputs chosen with **Control Signal 1 B** (P3.5.1.3) and **Control Signal 2 B** (P3.5.1.4). The functionality/logic for these inputs is selected with **I/O B Start/Stop Logic** (P3.2.7). The **I/O B Control Force** (P3.5.1.5) will determine when the Auto Control Place I/O B is in use.

Keypad (Hand) Control Place: Start and stop commands come from the keypad buttons, while the direction of the rotation is selected by **Keypad Direction** (P3.3.7). The speed of the motor is controlled from the keypad buttons or by setting **Keypad Reference** (P3.3.6). The **Keypad Control Reference Selection** (P3.3.5) must be set to a value of Keypad Reference for this work as stated.

Fieldbus Control Place: Start, stop, and reverse commands come from the fieldbus. The functionality/logic for the start/stop is selected with **Fieldbus Start Logic** (P3.2.8). The speed of the motor is controlled as selected with **Fieldbus Control Reference Selection** (P3.3.9).

Table 17: Start/Stop Parameters.

Structure	Parameter	Unit	Min	Max	Default	ID	Description
P3.2.1	Ctrl. Place Auto		I/O Control	Fieldbus Ctrl	I/O Control	172	Start/Stop commands are given differently depending upon the control place. This parameter defines whether the Start/Stop command is controlled by digital inputs as defined in Control Signal 1 A (P3.5.1.1) and Control Signal 2 A (P3.5.1.2) in accordance with the I/O A Start/Stop Logic (P3.2.6) or if the Start/Stop command is controlled by the fieldbus that is in use. Settings: 0 = I/O Control (<i>control is from the physical I/O, PID control, or time channels</i>) 1 = Fieldbus (<i>control is from the configured fieldbus found in Ethernet or RS-485 settings</i>)
P3.2.2	Hand/Auto		Auto	Hand	Auto	211	Defines the operational mode of the unit. 0 = Auto (controlled with I/O or fieldbus) 1 = Hand (controlled with keypad)
P3.2.3	KeypadStopButton		No	Yes	No	114	Defines the operational status of the keypad stop button as follows: 0 = No (stop button is not functional in all control places) 1 = Yes (stop button functions in all control places)
P3.2.4	Start Function		Ramping	Flying Start	Varies	505	Defines the start function of the drive. 0 = Ramping Start 1 = Flying Start

Structure	Parameter	Unit	Min	Max	Default	ID	Description
P3.2.5	Stop Function		Coasting	Ramping	Coasting	506	Defines the stop function of the drive. 0 = Coast to Stop 1 = Ramping Stop
P3.2.6	I/O A Logic		Forw-Back	Start-Rev (edge)	Forw-Back	300	See <i>I/O Table</i> .
P3.2.7	I/O B Logic		Forw-Back	Start-Rev (edge)	Forw-Back	363	Same as I/O A Logic (P3.2.6). I/O B Ctrl Force (P3.5.1.5) is used to determine when this logic is followed.
P3.2.8	FB Start Logic		Rising edge	State	Rising Edge	889	Defines the start logic when Ctrl. Place Auto (P3.2.1) is set to FieldbusCTRL. : 0 = Rising edge required 1 = State
P3.2.9	Start Delay		Disabled	Enabled	Disabled	14063	Enable parameter for a delayed start. If enabled, the drive will not start when a start is active until the amount of time defined in Start Delay Time (P3.2.10) has passed.
P3.2.10	Start Delay Time	s	0	320	0	14064	Defines the delay time before the drive will start after command is issued. Start Delay (P3.2.9) must be enabled.
P3.2.11	Mot. Interlock Start		Disabled	Enabled	Disabled	1811	Enable point for the interlock application. If enabled, the drive will energized the relay output defined for DmprIntlckLogic when a start is active. The drive will not start until Run Interlock 1 (P3.5.1.12) and Run Interlock 2 (P3.5.1.13) become active if Mot. InterlockTimeout (P3.1.12) is set to 0. Otherwise will activate after the time defined in Mot. InterlockTimeout (P3.1.12)
P3.2.12	Mot. InterlockTimeout	s	0	120	0	1816	Defines the amount of time the drive will wait for the interlock feedback to be given before starting. 0 = No timeout time used. Unit will wait indefinitely for the feedback before starting the drive. > 0 = Unit will only wait this time for the feedback, then start the drive.
P3.2.13	Run Interlock Proof					14060	Defines the run interlock proof timeout time. If Run Interlock 1 (P3.5.1.12) or Run Interlock 2 (P3.5.1.13) do not activate within the time defined, the response action defined in Run Interlock Fault (P3.9.29) will occur. This requires Mot. Interlock Start (P3.2.11) to be enabled.

Start Function (P3.2.4)

Table 18: Start Function.

Selection	Name	Description
0	Ramping	After the Start command, the speed of the motor is accelerated according to the set acceleration parameters to frequency setpoint.
1	Flying Start	After the Start command, the drive quickly adjusts the output frequency until the actual motor speed has been found. Then the motor ramps to the frequency setpoint.

Stop Function (P3.2.5)

Table 19: Stop Function.

Selection number	Selection name	Description
0	Coasting	The motor is allowed to stop on its own inertia. The control by the drive is discontinued and the drive current drops to zero as soon as the stop command is given.
1	Ramp	After the Stop command, the speed of the motor is decelerated according to the set deceleration parameters to zero speed.

I/O start/stop logic (P3.2.6)

Values 0 through 4 offer possibilities to control the starting and stopping of the drive with a digital signal connected to digital inputs. CS = Control signal.

Table 20: I/O Logic.

Logic	Operation Description
0	Ctrl Signal 1 A (P3.5.1.1) = Start Forward Ctrl Signal 2 A (P3.5.1.2) = Start Reverse Ctrl Signal 1 B (P3.5.1.3) = Start Forward Ctrl Signal 2 B (P3.5.1.4) = Start Reverse
1	Ctrl Signal 1 A (P3.5.1.1) = Start Forward (Edge) Ctrl Signal 2 A (P3.5.1.2) = Start Reverse (Edge) Ctrl Signal 1 B (P3.5.1.3) = Inverted Stop Ctrl Signal 2 B (P3.5.1.4) = Inverted Stop
2	Ctrl Signal 1 A (3.5.1.1) = Forward (Edge) Ctrl Signal 2 A (3.5.1.2) = Backward (Edge) Ctrl Signal 1 B (3.5.1.3) = Forward (Edge) Ctrl Signal 2 B (3.5.1.4) = Backward (Edge)
3	Ctrl Signal 1 A (P3.5.1.1) = Start Ctrl Signal 2 A (P3.5.1.2) = Reverse Ctrl Signal 1 B (P3.5.1.3) = Start Ctrl Signal 2 B (P3.5.1.4) = Reverse
4	Ctrl Signal 1 A (P3.5.1.1) = Start (Edge) Ctrl Signal 2 A (P3.5.1.2) = Reverse Ctrl Signal 1 B (P3.5.1.3) = Start (Edge) Ctrl Signal 2 B (P3.5.1.4) = Reverse

The selections including the text 'edge' shall be used to exclude the possibility of an unintentional start when, for example, power is connected, re-connected after a power failure, after a fault reset, after the drive is stopped by **Run Enable** (Run Enable = False) or when the control place is changed to I/O control.

NOTE: The Start/Stop contact must be opened before the motor can be started.
The used stop mode is *Coasting* in all examples.

Logic	Selection Name	Note
0	CS1: Forward CS2: Backward	The functions take place when the contacts are closed.

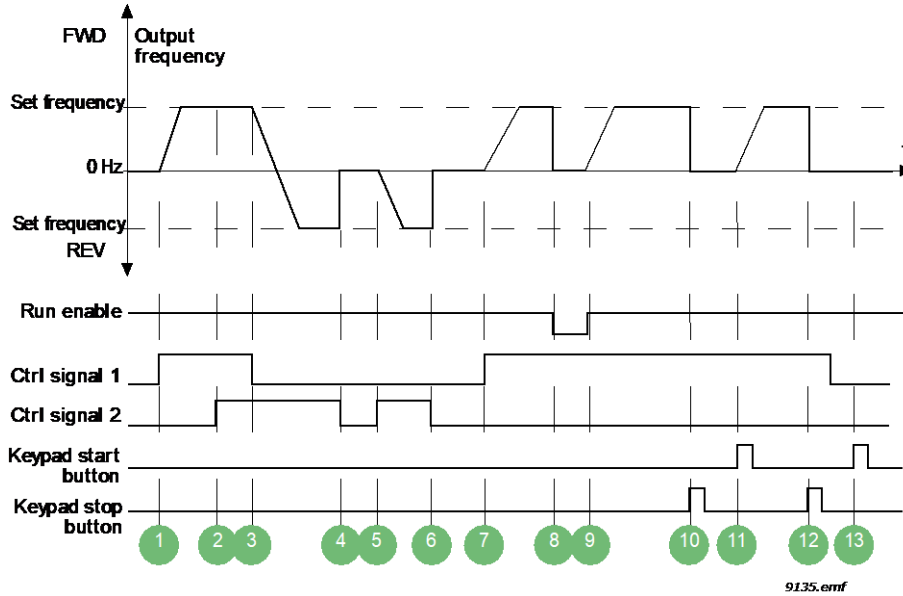

Figure 12: I/O A Start/Stop logic = 0.

Table 21: Legend to I/O A Start/Stop logic = 0.

1	Control signal (CS) 1 activates causing the output frequency to rise. The motor runs forward.	8	Run enable signal is set to FALSE, which drops the frequency to 0. The run enable signal is configured with RunEnable (P3.5.1.11).
2	CS2 activate, but has no effect on the output frequency because the first selected direction has the highest priority.	9	Run enable signal is set to TRUE, which causes the frequency to rise towards the set frequency because CS1 is still active.
3	CS1 is inactivated which causes the direction to start changing (FWD to REV) because CS2 is still active.	10	Keypad stop button is pressed and the frequency fed to the motor drops to 0. (This signal only works if KeypadStopButton [P3.2.3] = Yes)
4	CS2 inactivates and the frequency fed to the motor drops to 0.	11	The drive starts through pressing the Start button on the keypad.
5	CS2 activates again causing the motor to accelerate (REV) towards the set frequency.	12	The keypad stop button is pressed again to stop the drive.
6	CS2 inactivates and the frequency fed to the motor drops to 0.	13	The attempt to start the drive through pressing the Start button is not successful because CS1 is inactive.
7	CS1 activates and the motor accelerates (FWD) towards the set frequency.		

Logic	Selection Name	Note
1	CS1: Forward (edge) CS2: Inverted stop	

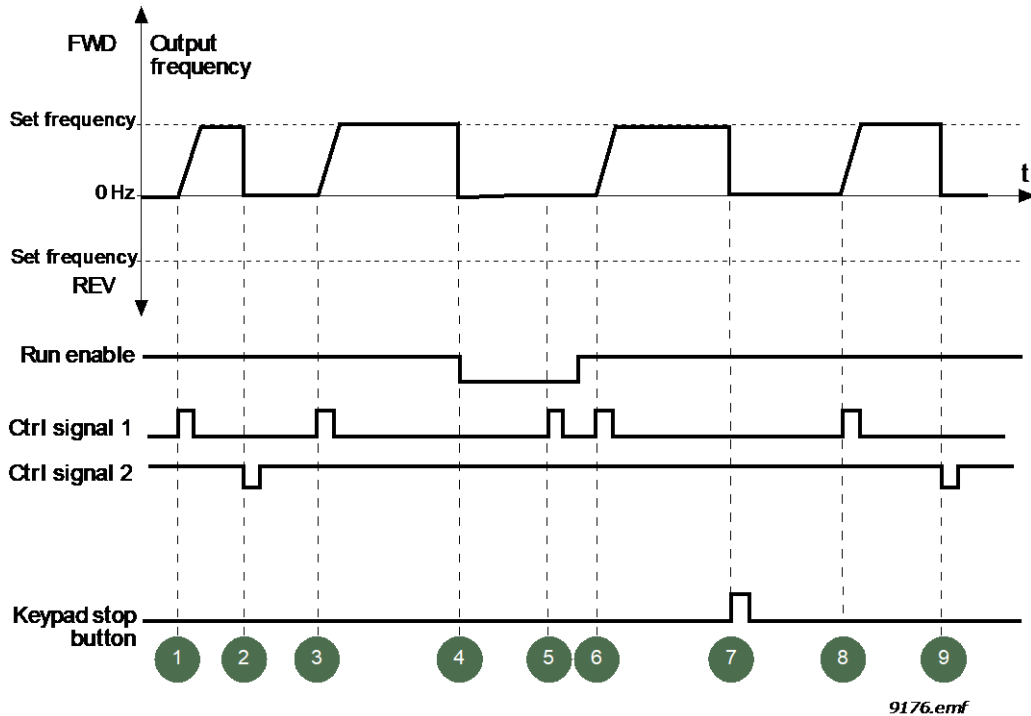
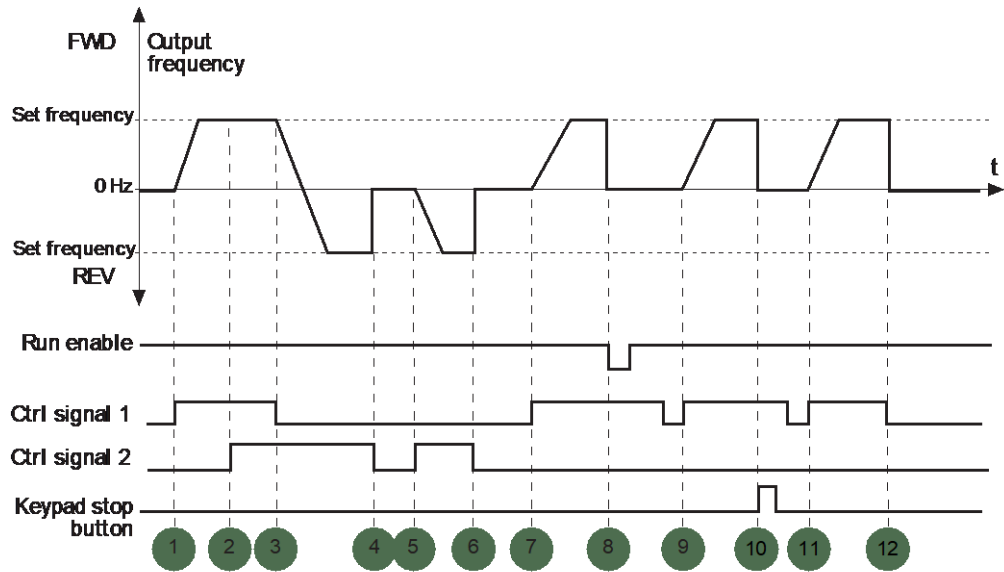

Figure 13: I/O A Start/Stop logic = 1.

Table 22: Legend to IO A Start/Stop logic = 1.

1	Control signal (CS) 1 activates causing the output frequency to rise. The motor runs forward.	6	CS1 activates and the motor accelerates (FWD) towards the set frequency because the Run enable signal has been set to TRUE.
2	CS2 inactivates causing the frequency to drop to 0.	7	Keypad stop button is pressed and the frequency fed to the motor drops to 0. (This signal only works if KeypadStopButton [P3.2.3] = Yes)
3	CS1 activates causing the output frequency to rise again. The motor runs forward.	8	CS1 activates causing the output frequency to rise again. The motor runs forward.
4	Run enable signal is set to FALSE, which drops the frequency to 0. The run enable signal is configured with Run Enable (P3.5.1.10).	9	CS2 inactivates causing the frequency to drop to 0.
5	Start attempt with CS1 is not successful because Run enable signal is still FALSE.		

Logic	Selection Name	Note
2	CS1: Forward (edge) CS2: Backward (edge)	Used to exclude the possibility of an unintentional start. The Start/Stop contact must be opened before the motor can be restarted.



11093.emf

Figure 14: I/O A Start/Stop logic = 2.

Table 23: Legend to I/O A Start/Stop logic = 2.

1	Control signal (CS) 1 activates causing the output frequency to rise. The motor runs forward.	7	CS1 activates and the motor accelerates (FWD) towards the set frequency
2	CS2 activates, but has no effect on the output frequency because the first selected direction has the highest priority.	8	Run enable signal is set to FALSE, which drops the frequency to 0. The run enable signal is configured with RunEnable (P3.5.1.11).
3	CS1 is inactivated which causes the direction to start changing (FWD to REV) because CS2 is still active.	9	Run enable signal is set to TRUE, which, unlike if value 0 is selected for this parameter, has no effect because rising edge is required to start even if CS1 is active.
4	CS2 inactivates and the frequency fed to the motor drops to 0.	10	Keypad stop button is pressed and the frequency fed to the motor drops to 0. (This signal only works if KeypadStopButton [P3.2.3] = Yes).
5	CS2 activates again causing the motor to accelerate (REV) towards the set frequency.	11	CS1 is opened and closed again which causes the motor to start.
6	CS2 inactivates and the frequency fed to the motor drops to 0.	12	CS1 inactivates and the frequency fed to the motor drops to 0.

Logic	Selection Name	Note
3	CS1: Start CS2: Reverse	

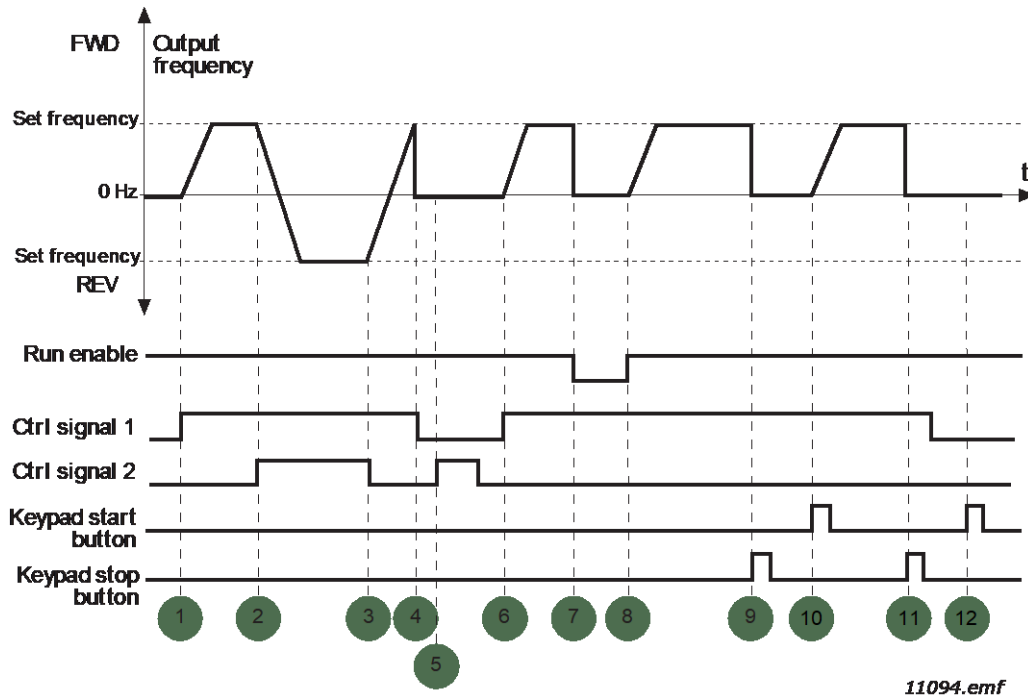
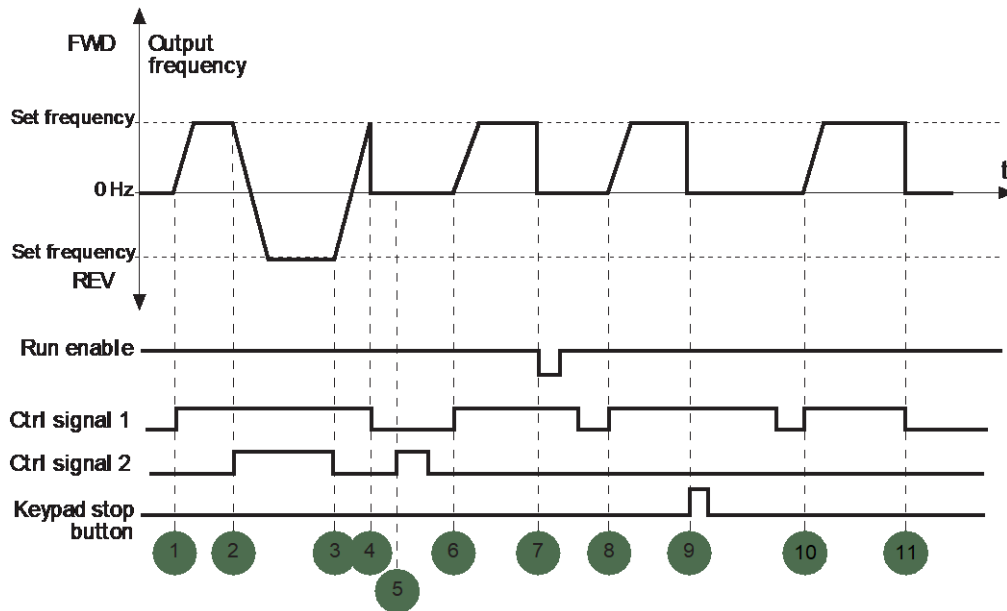

Figure 15: I/O A Start/Stop logic = 3.

Table 24: Legend to I/O A Start/Stop logic = 3.

1	Control signal (CS) 1 activates causing the output frequency to rise. The motor runs forward.	7	Run enable signal is set to FALSE, which drops the frequency to 0. The run enable signal is configured with Run Enable (P3.5.1.11).
2	CS2 activates which causes the direction to start changing (FWD to REV).	8	Run enable signal is set to TRUE, which causes the frequency to rise towards the set frequency because CS1 is still active.
3	CS2 is inactivated which causes the direction to start changing (REV to FWD) because CS1 is still active.	9	Keypad stop button is pressed and the frequency fed to the motor drops to 0. (This signal only works if KeypadStopButton [P3.2.3] = Yes).
4	Also CS1 inactivates and the frequency drops to 0.	10	The drive starts through pressing the Start button on the keypad.
5	Despite the activation of CS2, the motor does not start because CS1 is inactive.	11	The drive is stopped again with the stop button on the keypad.
6	CS1 activates causing the output frequency to rise again. The motor runs forward because CS2 is inactive.	12	The attempt to start the drive through pressing the Start button is not successful because CS1 is inactive.

Logic	Selection Name	Note
4	CS1: Start (edge) CS2: Reverse	Used to exclude the possibility of an unintentional start. The Start/Stop contact must be opened before the motor can be restarted.



11095.emf

Figure 16: I/O A Start/Stop logic = 4.

Table 25: Legend to I/O A Start/Stop logic = 4.

1	Control signal (CS) 1 activates causing the output frequency to rise. The motor runs forward because CS2 is inactive.	7	Run enable signal is set to FALSE , which drops the frequency to 0. The run enable signal is configured with Run Enable (P3.5.1.11).
2	CS2 activates which causes the direction to start changing (FWD to REV).	8	Before a successful start can take place, CS1 must be opened and closed again.
3	CS2 is inactivated which causes the direction to start changing (REV to FWD) because CS1 is still active.	9	Keypad stop button is pressed and the frequency fed to the motor drops to 0. (This signal only works if KeypadStopButton [P3.2.3] = Yes).
4	Also CS1 inactivates and the frequency drops to 0.	10	Before a successful start can take place, CS1 must be opened and closed again.
5	Despite the activation of CS2, the motor does not start because CS1 is inactive.	11	CS1 inactivates and the frequency drops to 0.
6	CS1 activates causing the output frequency to rise again. The motor runs forward because CS2 is inactive.		

Control reference settings (M3.3)

The frequency reference source is programmable for all control places except the computer, which always takes the reference from the PC tool.

Auto Control Place I/O A: The source of frequency reference can be selected **with I/O Control Reference A Selection** (P3.3.3). The **I/O B Reference Force** (P3.5.1.6) will determine when the I/O Control Reference B is in use.

Auto Control Place I/O B: The source of frequency reference can be selected **with I/O Control Reference B Selection** (P3.3.4). The **I/O B Reference Force** (P3.5.1.6) will determine when the I/O Control Reference B is in use.

Keypad (Hand) Control Place: The source of the frequency reference can be selected with **Keypad Control Reference Selection** (P3.3.5). If set to a value of Keypad Reference; then the keypad buttons or **Keypad Reference** (P3.3.6) can be used to set the frequency reference.

Fieldbus Control Place: The source of the frequency reference can be selected with **Fieldbus Control Reference Selection** (P3.3.9).

Table 26: Control Reference Settings.

Structure	Parameter	Unit	Min	Max	Default	ID	Description
P3.3.1	Min Frequency	Hz	0	Parameter P3.3.2	0	101	Minimum allowed frequency reference
P3.3.2	Max Frequency	Hz	Parameter P3.3.1	320	60	102	Maximum allowed frequency reference
P3.3.3	I/O A Ctrl Ref		PresetFreq0	Motor Pot Ref	AI1 + AI2	117	Selects location of frequency setpoint source when in I/O A control. In the following list of possible settings, the main setpoint is selected: 1 = Preset Freq 0 2 = Keypad Reference 3 = Fieldbus 4 = AI1 5 = AI2 6 = AI1+AI2 7 = PID 1 Reference 8 = Motor Potentiometer <i>Also see M1.10.</i>
P3.3.4	I/O B Ctrl Ref		PresetFreq0	Motor Pot Ref	AI1	131	Selects location of frequency setpoint source when in I/O B control. In the following list of possible settings, the main setpoint is selected: 1 = Preset Freq 0 2 = Keypad Reference 3 = Fieldbus 4 = AI1 5 = AI2 6 = AI1+AI2 7 = PID 1 Reference 8 = Motor Potentiometer I/O B Ref Force (P3.5.1.6) is used to determine when this reference is to be followed.

Structure	Parameter	Unit	Min	Max	Default	ID	Description
P3.3.5	Keypad Ctrl Ref		PresetFreq0	Motor Pot Ref	Keypad Ref	121	Defines the location of Keyboard Control Reference: 1 = Preset Freq 0 2 = Keypad Reference 3 = Fieldbus 4 = AI1 5 = AI2 6 = AI1+AI2 7 = PID 1 Reference 8 = Motor Potentiometer
P3.3.6	Keypad Reference	Hz	0	Parameter P3.3.2	0	184	Defines the frequency reference when in HAND (keypad) mode of operation.
P3.3.7	Keypad Direction		Forward	Reverse	Forward	123	Defines the motor rotation when in HAND (keypad) mode of operation 0 = Forward 1 = Reverse
P3.3.8	KeypadRefCopy		Copy Ref Run	No Copying	Copy Ref Run	181	Defines the function of Run State & Reference copy when switching to Keypad control. 0 = Copy Reference 1 = Copy Ref & Run State 2 = No Copy
P3.3.9	FieldbusCtrl Ref		PresetFreq0	Motor Pot Ref	Fieldbus	122	Defines the location of Fieldbus Control Reference: 1 = Preset Freq 0 2 = Keypad Reference 3 = Fieldbus 4 = AI1 5 = AI2 6 = AI1+AI2 7 = PID 1 Reference 8 = Motor Potentiometer
P3.3.10	PresetFreqMode		Binary Coded	Number of inputs	Binary Coded	182	Defines the preset frequency mode to be used: 0 = Binary Coded 1 = Number of inputs. Preset freq selected according to number of digital inputs.
P3.3.11	Preset Freq 0	Hz	Parameter P1.8 or P3.3.1	Parameter P1.9 or P3.3.2	5	180	Defines the frequency to be used when I/O A Ctrl Ref (P3.3.3), I/O B Ctrl Ref (P3.3.4), Keypad Ctrl Ref (P3.3.5) and/or FieldbusCtrl Ref (P3.3.9) is set to a value of Preset Freq 0 .

Structure	Parameter	Unit	Min	Max	Default	ID	Description
P3.3.12	Preset Freq 1	Hz	Parameter P1.8 or P3.3.1	Parameter P1.9 or P3.3.2	10	105	Defines the frequency to be used when the following occurs: 1. PresetFreqMode (P3.3.10) is set to Binary Coded and Preset Freq Sel0 (P3.5.1.15) is activated. Preset Freq Sel1 (P3.5.1.16) is deactivated. Preset Freq Sel2 (P3.5.1.17) is deactivated. 2. PresetFreqMode (P3.3.10) is set to Number of Inputs & Preset Freq Sel0 (3.5.1.15) is activated. Preset Freq Sel1 (3.5.1.16) is deactivated. Preset Freq Sel2 (3.5.1.17) is deactivated.
P3.3.13	Preset Freq 2	Hz	Parameter P1.8 or P3.3.1	Parameter P1.9 or P3.3.2	15	106	Defines the frequency to be used when the following occurs: 1. PresetFreqMode (P3.3.10) is set to Binary Coded and Preset Freq Sel0 (P3.5.1.15) is deactivated. Preset Freq Sel1 (P3.5.1.16) is activated. Preset Freq Sel2 (P3.5.1.17) is deactivated. 2. PresetFreqMode (P3.3.10) is set to Number of Inputs & Preset Freq Sel0 (P3.5.1.15) is deactivated. Preset Freq Sel1 (P3.5.1.16) is activated. Preset Freq Sel2 (P3.5.1.17) is deactivated.
P3.3.14	Preset Freq 3	Hz	Parameter P1.8 or P3.3.1	Parameter P1.9 or P3.3.2	20	126	Defines the frequency to be used when the following occurs: 1. PresetFreqMode (P3.3.10) is set to Binary Coded & Preset Freq Sel0 (P3.5.1.15) is activated. Preset Freq Sel1 (P3.5.1.16) is activated. Preset Freq Sel2 (P3.5.1.17) is deactivated. 2. PresetFreqMode (P3.3.10) is set to Number of Inputs & Preset Freq Sel0 (P3.5.1.15) is deactivated. Preset Freq Sel1 (P3.5.1.16) is deactivated. Preset Freq Sel2 (P3.5.1.17) is activated.

Structure	Parameter	Unit	Min	Max	Default	ID	Description
P3.3.15	Preset Freq 4	Hz	Parameter P1.8 or P3.3.1	Parameter P1.9 or P3.3.2	25	127	Defines the frequency to be used when the following occurs: 1. PresetFreqMode (P3.3.10) is set to Binary Coded & Preset Freq Sel0 (P3.5.1.15) is deactivated. Preset Freq Sel1 (P3.5.1.16) is deactivated. Preset Freq Sel2 (P3.5.1.17) is activated.
P3.3.16	Preset Freq 5	Hz	Parameter P1.8 or P3.3.1	Parameter P1.9 or P3.3.2	30	128	Defines the frequency to be used when the following occurs: 1. PresetFreqMode (P3.3.10) is set to Binary Coded & Preset Freq Sel0 (P3.5.1.15) is activated. Preset Freq Sel1 (P3.5.1.16) is deactivated. Preset Freq Sel2 (P3.5.1.17) is activated.
P3.3.17	Preset Freq 6	Hz	Parameter 1.8 or P3.3.1	Parameter 1.9 or P3.3.2	40	129	Defines the frequency to be used when the following occurs: 1. PresetFreqMode (P3.3.10) is set to Binary Coded & Preset Freq Sel0 (P3.5.1.15) is deactivated. Preset Freq Sel1 (P3.5.1.16) is activated. Preset Freq Sel2 (P3.5.1.17) is activated.
P3.3.18	Preset Freq 7	Hz	Parameter P1.8 or P3.3.1	Parameter P1.9 or P3.3.2	50	130	Defines the frequency to be used when the following occurs: 1. PresetFreqMode (P3.3.10) is set to Binary Coded & Preset Freq Sel0 (P3.5.1.15) is activated. Preset Freq Sel1 (P3.5.1.16) is activated. Preset Freq Sel2 (P3.5.1.17) is activated.
P3.3.19	PresetAlarmFreq	Hz	Parameter P1.8 or P3.3.1	Parameter P1.9 or P3.3.2	25	183	Defines the frequency to be followed when fault responses (found in Protections [P3.9]) are defined for Alarm + Preset Freq. AI Low Fault (P3.9.1) FieldbusComm Flt (P3.9.19)
P3.3.20	MotPot Ramp Time	Hz/s	0.1	500	10	331	Rate of change in the motor potentiometer reference when increased or decreased.
P3.3.21	MotPot Reset		No Reset	Powered down	Stop State	367	Motor potentiometer frequency reference reset logic 0 = No Reset 1 = Reset if stop state 2 = Reset if powered down

Understanding Preset Frequencies

Preset frequency mode (P3.3.10)

You can use the preset frequency parameters to define certain frequency references in advance. These references are then applied by activating/deactivating the digital inputs connected to parameters **Preset frequency selection 0** (P3.5.1.15), **Preset frequency selection 1** (P3.5.1.16) and **Preset frequency selection 2** (P3.5.1.17). Two different logics can be selected:

Table 27: Preset Frequency Logic.

Selection number	Selection name	Note
0	Binary coded	Combine activated inputs according to the table below to choose the Preset frequency needed.
1	Number (of inputs used)	You can apply the <i>Preset frequencies</i> 1 to 3, depending on how many of the inputs assigned for <i>Preset frequency selections</i> are active.

Binary Coded Operation

The values of the preset frequencies are automatically limited between the **Minimum Frequency** (P3.3.1) and **Maximum Frequency** (P3.3.2). The following table displays the operation to select the preset frequencies:

Table 28: Preset Frequencies 1 Through 7.

Required Action For use with 1/O Control Reference (P3.3.3), Preset Freq0 is selected.			Activated Frequency Preset Frequency 0 (P3.3.11)
B2 (P3.5.1.17)	B1 (P3.5.1.16)	B0 (P3.5.1.15)	
Off	Off	On	Preset Frequency 1 (P3.3.12)
Off	On	Off	Preset Frequency 2 (P3.3.13)
Off	On	On	Preset Frequency 3 (P3.3.14)
On	Off	Off	Preset Frequency 4 (P3.3.15)
On	Off	On	Preset Frequency 5 (P3.3.16)
On	On	Off	Preset Frequency 6 (P3.3.17)
On	On	On	Preset Frequency 7 (P3.3.18)

Number of Inputs Operation

The values of the preset frequencies are automatically limited between the **Minimum Frequency** (P3.3.1) and **Maximum Frequency** (P3.3.2). The following table displays the operation to select the preset frequencies:

Table 29: Number of Inputs Used: Preset Frequencies 1 through 3.

Required Action For use with 1/O Control Reference (P3.3.3), Preset Freq0 is selected.			Activated Frequency Preset Frequency 0 (P3.3.11)
B2 (P3.5.1.17)	B1 (P3.5.1.16)	B0 (P3.5.1.15)	
Off	Off	On	Preset Frequency 1 (P3.3.12)
Off	On	Off	Preset Frequency 2 (P3.3.13)
On	Off	On	Preset Frequency 3 (P3.3.14)

Ramp and Brakes Setup (M3.4)

Two ramps are available (two sets of acceleration times, deceleration times, and ramp shapes). The second ramp can be activated using a digital input.



NOTE:

Ramp 2 always has higher priority and is used if a digital input for **Accel/Decel Time Selection** (P.5.1.33) is activated.

The ramps and brakes settings are presented in the following table:

Table 30: Ramp and Brakes Settings.

Structure	Parameter	Unit	Min	Max	Default	ID	Description
P3.4.1	Ramp 1 Shape	s	0	10	0	500	S-curve time ramp 1.
P3.4.2	Accel Time 1	s	0.1	3000	20	103	Defines the time required to increase output freq from 0 to Max Frequency (P3.3.1).
P3.4.3	Decel Time 1	s	0.1	3000	20	104	Defines the time required to decrease output freq from Max Frequency (P3.3.1) to 0 frequency.
P3.4.4	Ramp 2 Shape	s	0	10	0	501	S-curve time ramp 2.
P3.4.5	Accel Time 2	s	0.1	3000	10	502	Defines the time required to increase output freq from 0 to Max Frequency (P3.3.1).
P3.4.6	Decel Time 2	s	0.1	3000	10	503	Defines the time required to decrease output freq from Max Frequency (P3.3.1) to 0 frequency.
P3.4.7	StartMagnTime	s	0	600	0	516	Defines the time for how long DC current is fed to motor before acceleration starts.
P3.4.8	StartMagnCurrent	A	Varies	Varies	Varies	517	Defines the DC current to be used at start of the motor.
P3.4.9	DC Time Stop	s	0	600	0	508	Determines if braking is ON or OFF and the braking time of the DC brake when the motor is stopping.
P3.4.10	DC Brake Current	A	Varies	Varies	Varies	507	Defines the current injected into the motor during DC braking. 0 = Disabled
P3.4.11	DC BrakeFreqStop	Hz	0.1	10	1.5	515	The output frequency at which the DC braking is applied.
P3.4.12	Flux Braking		Disabled	Enabled	Disabled	520	Settings: 0 = Disabled 1 = Enabled
P3.4.13	FluxBrakeCurrent	A	0	Varies	Varies	519	Defines the current level for Flux braking.

Ramp 1 shape (P3.4.1)

The start and end of acceleration and deceleration ramps can be smoothed with this parameter. Setting value 0 gives a linear ramp shape which causes acceleration and deceleration to act immediately to the changes in the reference signal.

Setting value 0.1 to 10 seconds for this parameter produces an S-shaped acceleration/deceleration. The acceleration time is determined with **Accel Time 1** (P3.4.2) and **Decel Time 1** (P3.4.3). See the following figure.

These parameters are used to reduce mechanical erosion and current spikes when the reference is changed.

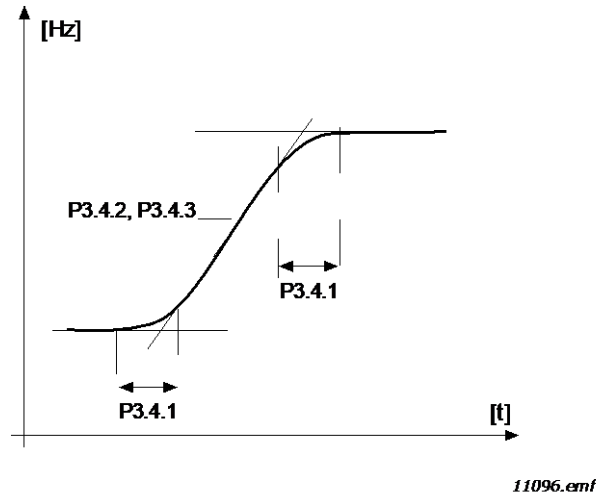

Figure 17: Acceleration/Deceleration (S-shaped).

Flux braking (P3.4.12)

Instead of DC braking, flux braking is a useful way to raise the braking capacity in cases where additional brake resistors are not needed.

When braking is needed, the frequency is reduced and the flux in the motor is increased, which in turn increases the motor's capability to brake. Unlike DC braking, the motor speed remains controlled during braking.

The flux braking can be set ON or OFF.



NOTE:

Flux braking converts the energy into heat at the motor, and should be used intermittently to avoid motor damage.

I/O Configuration (M3.5)

The I/O configuration is used to attach features/functions of the drive to the controlling I/O or control source. There are four I/O configuration areas: Digital Inputs, Digital Outputs, Analog Inputs, and Analog Outputs.

Digital Inputs (M3.5.1)

The digital inputs are very flexible to use. Parameters are functions/features that are connected to the required digital input terminals. The digital inputs are represented by the slot they exist on. For example, **DigIN Slot A.2** means the second digital input on slot A (basic I/O). It is possible for the function/feature to be always disabled (or enabled) by using the virtual slot0. For example, to leave a parameter as normally open all the time, it would be programmed as **DigIN Slot0.1**. Likewise, to leave a parameter as normally closed all the time, it would be programmed as **DigIN Slot0.2**.

It is also possible to connect the digital inputs to time channels which are also represented as terminals. For example, to run the drive in reverse in accordance with the first time channel, it would be programmed as **TimeChannel.1**.



NOTE:

The status of the digital inputs can be monitored in the **multimonitor** (M2.1) view, or in the I/O and **Hardware** (M5) menu.

The digital inputs settings are presented in the following table:

Table 31: Digital Inputs Settings.

Structure	Parameter	Default	ID	Description
P3.5.1.1	Ctrl Signal 1 A (Start Forward)	DigIN SlotA.1	403	Defines the location for selection of Control Signal 1 A as defined by I/O A Logic (P3.2.6) [Start Forward]. Possible settings are as follows: TimeChannel.# DigIN Slot0.# DigIN SlotA.# DigIN SlotC.# DigIN SlotD.# DigIN SlotE.# <i>Where # is the channel number or occurrence number.</i> NOTE: Slot C, D, and E available if option cards are installed and contain Digital Input type objects.
P3.5.1.2	Ctrl Signal 2 A (Start Reverse)	DigIN SlotA.2	404	Defines the location for selection of Control Signal 2 A as defined by I/O A Logic (P3.2.6) [Start Reverse]. Possible settings are the same as Ctrl Signal 1 A (P3.5.1.1).
P3.5.1.3	Ctrl Signal 1 B (Start Forward)	DigIN Slot0.1	423	Defines the location for selection of Control Signal 1 B as defined by I/O B Logic (P3.2.7) [Start Forward]. Possible settings are the same as Ctrl Signal 1 A (P3.5.1.1).
P3.5.1.4	Ctrl Signal 2 B (Start Reverse)	DigIN Slot0.1	424	Defines the location for selection of Control Signal 2 B as defined by I/O B Logic (P3.2.7) [Start Reverse]. Possible settings are the same as Ctrl Signal 1 A (P3.5.1.1).
P3.5.1.5	I/O B Ctrl Force	DigIN Slot0.1	425	Defines the location to determine when I/O B Logic (P3.2.7) should be followed. Open Contact = I/O A Logic (P3.2.6) is followed. Contact Closure = I/O B Logic (P3.2.7) is followed.
P3.5.1.6	I/O B Ref Force	DigIN Slot0.1	343	Defines the location to determine when I/O B Ctrl Ref (P3.3.4) should be followed. Open Contact = I/O A Ctrl Ref (P3.3.3) is followed. Contact Closure = I/O B Ctrl Ref (P3.3.4) is followed.
P3.5.1.7	Ext Fault Close	DigIN SlotA.3	405	Defines the location to monitor to generate response to External Fault (P3.9.2) on contact closure. Open Contact = OK Contact Closure = External Fault Active
P3.5.1.8	Ext Fault Open	DigIN Slot0.2	406	Defines the location to monitor to generate response to External Fault (P3.9.2) on contact open. Open Contact = External Fault Active Contact Closure = OK
P3.5.1.9	Fault Reset Close	DigIN SlotA.6	414	Defines the location of fault reset on contact closure (rising edge). Contact Closure = Reset
P3.5.1.10	Fault Reset Open	DigIN Slot0.1	213	Defines the location of fault reset on open contact (falling edge). Open Contact = Reset
P3.5.1.11	Run Enable	DigIN Slot0.2	407	Defines the location of the run enable. Open Contact = Disabled = NOT READY Contact Closure = Enabled = READY The VFD is stopped according to the Stop Function (P3.2.5). NOTE: When fieldbus is used, refer to FB Run Enable (P3.6.9).

Structure	Parameter	Default	ID	Description
P3.5.1.12	Run Interlock 1	DigIN Slot0.2	1041	Defines the input monitored for proof of the interlock application when Mot. Interlock Start (P3.2.11) is enabled . The drive cannot be started if any of the interlocks are open. This function can be used for a damper interlock, preventing the drive from starting with the damper closed.
P3.5.1.13	Run Interlock 2	DigIN Slot0.2	1042	Defines the input monitored for proof of the interlock application when Mot. Interlock Start (P3.2.11) is enabled . The Drive cannot be started if any of the interlocks are open. This function can be used for a damper interlock, preventing the Drive from starting with the damper closed.
P3.5.1.14	PreHeat ON	DigIN Slot0.1	1044	Used when Preheat Function (P3.1.2.5) is set to 2 0 = No action 1 = Used motor preheat DC current in Stop state
P3.5.1.15	Preset Freq Sel0	DigIN SlotA.4	419	Defines the location for the binary selector 0 used with PresetFreqMode (P3.3.10), and Preset Freq 1 (P3.3.12), through Preset Freq 7 (P3.3.18).
P3.5.1.16	Preset Freq Sel1	DigIN SlotA.5	420	Defines the location for the binary selector 0 used with PresetFreqMode (P3.3.10), and Preset Freq 1 (P3.3.12), through Preset Freq 7 (P3.3.18).
P3.5.1.17	Preset Freq Sel2	DigIN Slot0.1	421	Defines the location for the binary selector 0 used with PresetFreqMode (P3.3.10), and Preset Freq 1 (P3.3.12), through Preset Freq 7 (P3.3.18).
P3.5.1.18	Timer 1	DigIN Slot0.1	447	Defines the location to the rising edge to start timer 1 as programmed in Timer Functions (P3.11) menu structure.
P3.5.1.19	Timer 2	DigIN Slot0.1	448	Defines the location to the rising edge to start timer 2 as programmed in Timer Functions (P3.11) menu structure.
P3.5.1.20	Timer 3	DigIN Slot0.1	449	Defines the location to the rising edge to start timer 3 as programmed in Timer Functions (P3.11) menu structure.
P3.5.1.21	Disable Timer Funct.	DigIN Slot0.1	1499	Enable parameter for all timer functions including Intervals 1-5 and Timer 1-3 (programmable in Timer Functions (P3.11) menu structure). Contact closure = Timer functions and reset timers disabled Open Contact = Timer functions and reset timers enabled
P3.5.1.22	PID1 Boost SP	DigIN Slot0.1	1047	Defines the location for applying boost to PID1 setpoint. Contact closure = Boost Open Contact = No Boost
P3.5.1.23	PID1 Select SP	DigIN Slot0.1	1046	Defines the location to determine which setpoint is to be used with PID1. Open Contact = Setpoint 1 Contact Closure = Setpoint 2
P3.5.1.24	PID2 Start Signal	DigIN Slot0.2	1049	Parameter will have no effect if PID2 controller is not enabled in the basic menu for PID2. Open Contact = PID2 in stop mode Contact Closure = PID2 regulating
P3.5.1.25	PID2 Select SP	DigIN Slot0.1	1048	Defines the location to determine which setpoint is to be used with PID2. Open Contact = Setpoint 1 Contact Closure = Setpoint 2
P3.5.1.26	Interlock 1	DigIN Slot0.1	426	Defines the location for the interlock feedback for motor 1 when using the multi-pump feature.
P3.5.1.27	Interlock 2	DigIN Slot0.1	427	Defines the location for the interlock feedback for motor 2 when using the multi-pump feature.

Structure	Parameter	Default	ID	Description
P3.5.1.28	Interlock 3	DigIN Slot0.1	428	Defines the location for the interlock feedback for motor 3 when using the multi-pump feature.
P3.5.1.29	Interlock 4	DigIN Slot0.1	429	Defines the location for the interlock feedback for motor 4 when using the multi-pump feature.
P3.5.1.30	Interlock 5	DigIN Slot0.1	430	Defines the location for the interlock feedback for motor 5 when using the multi-pump feature.
P3.5.1.31	MotPot UP	DigIN Slot0.1	418	Defines the location for the motor potentiometer reference that will be used to increase the speed. Contact closure = increase speed setpoint.
P3.5.1.32	MotPot Down	DigIN Slot0.1	417	Defines the location for the motor potentiometer reference that will be used to decrease the speed Contact closure = decrease speed setpoint
P3.5.1.33	Acc/Dec Time Sel	DigIN Slot0.1	408	Defines the location for accel/decel time selection. Open Contact = Ramp 1 shape (P3.4.1), Accel1 (P3.4.2), and Decel1 (P3.4.3) to be followed Contact Closure = Ramp 2 shape (P3.4.4), Accel2 (P3.4.5), and Decel 2 (P3.4.6) to be followed
P3.5.1.34	Fieldbus Ctrl	DigIN Slot0.1	411	Defines the location to force control place to fieldbus. Open Contact = I/O Control Contact closure = Fieldbus Control
P3.5.1.39	FireMode Activ.Open	DigIN Slot0.2	1569	Defines location of fire mode activation on contact opening. Open Contact = Fire Mode Active Contact Closure = No Action <i>Also see Menu Structure P3.16.2.</i>
P3.5.1.40	FireMode Activ.Close	DigIN Slot0.1	1619	Defines location of fire mode activation on contact closing. Open Contact = No Action Contact Closure = Fire Mode Active <i>Also see Menu Structure P3.16.3.</i>
P3.5.1.41	FireMode Reverse	DigIN Slot0.1	1618	Defines location of the reverse command when fire mode is active as defined by FireMode Activ.Open (P3.16.2) or FireMode Activ.Close (P3.16.3). Open Contact = Forward Contact Closure = Reverse NOTE: This function has no effect in normal mode of operation. <i>Also see Menu Structure P3.16.6.</i>
P3.5.1.42	Keypad CTRL	DigIN Slot0.1	410	Defines the location monitored to force the Control Place to Keypad.
P3.5.1.43	Reset kWh Counter	DigIN Slot0.1	1053	Defines the location of the kWh trip counter reset.
P3.5.1.44	Remote Safety 1*	DigIN SlotA.2	1814	Defines the location of the remote safety.
P3.5.1.45	Remote Safety 2*	DigIN SlotA.3	1815	Defines the location of the remote safety.
P3.5.1.46	Remote Safety 3*	DigIN Slot0.2	1819	Defines the location of the remote safety.
P3.5.1.47	Remote Safety 4*	DigIN Slot0.2	1820	Defines the location of the remote safety.
P3.5.1.48	Remote Safety 5*	DigIN Slot0.2	1821	Defines the location of the remote safety.
P3.5.1.49	Remote Safety 6*	DigIN Slot0.2	1822	Defines the location of the remote safety.

Structure	Parameter	Default	ID	Description
P3.5.1.50	Remote Safety 7*	DigIN Slot0.2	1823	Defines the location of the remote safety.
P3.5.1.51	Remote Safety 8*	DigIN Slot0.2	1824	Defines the location of the remote safety.
P3.5.1.52	Essential Services*	DigIN Slot0.1	1827	Defines the location of the essential service activation signal. NOTE: Requires EssentServEnable (P3.18.5) to be enabled to take effect.
P3.5.1.53	Overload (Accessible when Bypass (P3.17.4) = Electronic or Conventional)	DigIN SlotA.5	1825	Defines the location of the bypass overload relay. NOTE: Is it not recommended to change this value. The overload relay is factory wired to digital input 5 on all Conventional and Electronic Bypass options.

*Accessible only when **Bypass** (P3.17.4) is set to a value of **Electronic**.

Analog Inputs (M3.5.2)

The analog inputs are very flexible to use. Parameters are functions/features that connect to the required analog input terminals. The analog inputs are represented by the slot they exist on. Analog inputs 1 and 2 exist by default on SlotA. For example, **AI 1 Signal Selection** (P3.5.2.1) would connect analog input 1 when set as **AnIN SlotA.1**.



NOTE:

The status of the analog inputs can be monitored in the **Multimonitor** (M2.1) view, or in the I/O and **Hardware** (M5) menu.

The analog inputs settings are presented in the following table:

Table 32: Analog Inputs Settings.

Structure	Parameter	Unit	Min	Max	Default	ID	Description
P3.5.2.1	AI1 Signal Sel				AnIN SlotA.1	377	Defines the location of the signal to be used as analog input 1.
P3.5.2.2	AI1 Filter Time	s	0	300	1	378	Defines the time it takes to reach 63% of a step change in the analog input signal defined by AI1 Signal Sel (P3.5.2.1). When this parameter is given a value > 0, the function that filters out disturbances from the incoming analog signal is activated. NOTE: Long filtering time makes the regulation response slower.
P3.5.2.3	AI1 Signal Range		0-10V/ 0-20 mA	2-10V/ 4-20 mA	0-10V/ 0-20 mA	379	Defines the signal range for the analog input defined by AI1 Signal Sel (P3.5.2.1). Ranges are as follows: 0 = 0 to 10 Vdc/0 to 20 mA 1 = 2 to 10 Vdc 4 to 20 mA NOTE: This setting can be bypassed by using AI1 Custom Min (P3.5.2.4) and AI1 Custom Max (P3.5.2.5).
P3.5.2.4	AI1 Custom Min	%	-160	160	0	380	Defines the custom minimum to be used for bypassing the AI1 Signal Range (P3.5.2.3).

Structure	Parameter	Unit	Min	Max	Default	ID	Description
P3.5.2.5	AI1 Custom Max	&	-160	160	100	381	Defines the custom maximum to be used for bypassing the AI1 Signal Range (P3.5.2.3).
P3.5.2.6	AI1 Signal Inv		Normal	Inverted	Normal	387	Defines the operation of the analog input 1 signal as follows: Normal = 0V or 0 mA = 0%, 10V or 20 mA = 100%. Inverted = 0V or 0 mA = 100%, 10V or 20 mA = 0%.
P3.5.2.7	AI2 Signal Sel				AnIN SlotA.2	388	Defines the location of the signal to be used as analog input 2.
P3.5.2.8	AI2 Filter Time	s	0	300	1	389	Defines the time it takes to reach 63% of a step change in the analog input signal defined by AI2 Signal Sel (P3.5.2.7).
P3.5.2.9	AI2 Signal Range		0-10V/0-20mA	2-10V/4-20mA	0-10V/0-20mA	390	Defines the signal range for the analog input defined by AI2 Signal Sel (P3.5.2.7). Ranges are as follows: 0 = 0 to 10 Vdc/0 to 20 mA 1 = 2 to 10 Vdc / 4..20 mA NOTE: This setting can be bypassed by using AI2 Custom Min (P3.5.2.10) and AI2 Custom Max (P3.5.2.11).
P3.5.2.10	AI2 Cutom Min	%	-160	160	0	391	Defines the custom minimum to be used for bypassing the AI2 Signal Range (P3.5.2.9).
P3.5.2.11	AI2 Custom Max	&	-160	160	100	392	Defines the custom maximum to be used for bypassing the AI2 Signal Range (P3.5.2.9).
P3.5.2.12	AI2 Signal Inv		Normal	Inverted	Normal	398	Defines the operation of the analog input 2 signal as follows: Normal = 0V or 0 mA = 0%, 10V or 20 mA = 100% Inverted = 0V or 0 mA = 100%, 10V or 20 mA = 0%
P3.5.2.13	AI3 Signal Sel				AnIN Slot0.1	141	Defines the location of the signal to be used as analog input 3.
P3.5.2.14	AI3 Filter Time	s	0	300	1	142	Defines the time it takes to reach 63% of a step change in the analog input signal defined by AI3 Signal Sel (P3.5.2.13).
P3.5.2.15	AI3 Signal Range		0-10V/0-20mA	2-10V/4-20mA	0-10V/0-20 mA	143	Defines the signal P3.5.2.13). Ranges are as follows: 0 = 0 to 10 Vdc/0 to 20 mA 1 = 2 to 10 Vdc/4 to 20 mA NOTE: This setting can be bypassed by using AI3 Custom Min (P3.5.2.16) and AI3 Custom Max (P3.5.2.17).
P3.5.2.16	AI3 Cutom Min	%	-160	160	0	144	Defines the custom minimum to be used for bypassing the AI3 Signal Range (P3.5.2.15).

Structure	Parameter	Unit	Min	Max	Default	ID	Description
P3.5.2.17	AI3 Custom Max	&	-160	160	100	145	Defines the custom maximum to be used for bypassing the AI3 Signal Range (P3.5.2.15).
P3.5.2.18	AI3 Signal Inv		Normal	Inverted	Normal	151	Defines the operation of the analog input 3 signal as follows: Normal = 0V or 0 mA = 0%, 10V or 20 mA = 100% Inverted = 0V or 0 mA = 100%, 10V or 20m A = 0%
P3.5.2.19	AI4 Signal Sel				AnIN Slot0.1	152	Defines the location of the signal to be used as analog input 4.
P3.5.2.20	AI4 Filter Time	s	0	300	1	153	Defines the time it takes to reach 63% of a step change in the analog input signal defined by AI4 Signal Sel (P3.5.2.19).
P3.5.2.21	AI4 Signal Range		0-10V/ 0-20mA	2-10V/ 4-20mA	0-10V/ 0-20mA	154	Defines the signal range for the analog input defined by AI4 Signal Sel (P3.5.2.19). Ranges are as follows: 0 = 0 to 10 Vdc/0 to 20 mA 1 = 2 to 10 Vdc/4 to 20 mA NOTE: This setting can be bypassed by using AI4 Custom Min (P3.5.2.22) and AI4 Custom Max (P3.5.2.23).
P3.5.2.22	AI4 Cutom Min	%	-160	160	0	155	Defines the custom minimum to be used for bypassing the AI4 Signal Range (P3.5.2.21).
P3.5.2.23	AI4 Custom Max	&	-160	160	100	156	Defines the custom maximum to be used for bypassing the AI4 Signal Range (P3.5.2.21).
P3.5.2.24	AI4 Signal Inv		Normal	Inverted	Normal	162	Defines the operation of the analog input 4 signal as follows: Normal = 0V or 0 mA = 0%, 10V or 20 mA = 100% Inverted = 0V or 0 mA = 100%, 10V or 20 mA = 0%
P3.5.2.25	AI5 Signal Sel				AnIN Slot0.1	188	Defines the location of the signal to be used as analog input 5.
P3.5.2.26	AI5 Filter Time	s	0	300	1	189	Defines the time it takes to reach 63% of a step change in the analog input signal defined by AI5 Signal Sel (P3.5.2.25).
P3.5.2.27	AI5 Signal Range		0-10V/ 0-20 mA	2-10V/ 4-20 mA	0-10V/ 0-20 mA	190	Defines the signal range for the analog input defined by AI5 Signal Sel (P3.5.2.25). Ranges are as follows: 0 = 0 to 10 Vdc/0 to 20 mA 1 = 2 to 10 Vdc/4 to 20 mA NOTE: This setting can be bypassed by using AI5 Custom Min (P3.5.2.28) and AI5 Custom Max (P3.5.2.29).

Structure	Parameter	Unit	Min	Max	Default	ID	Description
P3.5.2.28	AI5 Cutom Min	%	-160	160	0	191	Defines the custom minimum to be used for bypassing the AI5 Signal Range (P3.5.2.27).
P3.5.2.29	AI5 Custom Max	&	-160	160	100	192	Defines the custom maximum to be used for bypassing the AI5 Signal Range (P3.5.2.27).
P3.5.2.30	AI5 Signal Inv		Normal	Inverted	Normal	198	Defines the operation of the analog input 5 signal as follows: Normal = 0V or 0 mA = 0%, 10V or 20 mA = 100% Inverted = 0V or 0 mA = 100%, 10V or 20 mA = 0%
P3.5.2.31	AI6 Signal Sel				AnIN Slot0.1	199	Defines the location of the signal to be used as analog input 6.
P3.5.2.32	AI6 Filter Time	s	0	300	1	200	Defines the time it takes to reach 63% of a step change in the analog input signal defined by AI6 Signal Sel (P3.5.2.31).
P3.5.2.33	AI6 Signal Range		0-10V/ 0-20mA	2-10V/ 4-20 mA	0-10V/ 0-20 mA	201	Defines the signal range for the analog input defined by AI6 Signal Sel (P3.5.2.31). Ranges are as follows: 0 = 0 to 10 Vdc/0 to 20 mA 1 = 2 to 10 Vdc/4 to 20 mA NOTE: This setting can be bypassed by using AI6 Custom Min (P3.5.2.34) and AI6 Custom Max (P3.5.2.35).
P3.5.2.34	AI6 Cutom Min	%	-160	160	0	203	Defines the custom minimum to be used for bypassing the AI6 Signal Range (P3.5.2.33).
P3.5.2.35	AI6 Custom Max	&	-160	160	100	204	Defines the custom maximum to be used for bypassing the AI6 Signal Range (P3.5.2.33).
P3.5.2.36	AI6 Signal Inv		Normal	Inverted	Normal	209	Defines the operation of the analog input 6 signal as follows: Normal = 0V or 0 mA = 0%, 10V or 20 mA = 100% Inverted = 0V or 0 mA = 100%, 10V or 20 mA = 0%

Digital Outputs (M3.5.3)

The digital/relay outputs are very flexible to use. Parameters are functions/features that are connected to the required digital/relay output terminals. The digital outputs are configured by the slot they exist on. If no expansion board exists, then the option does not populate with data.



NOTE:

The status of the Digital/Relay Outputs can be monitored in the **Multimonitor** (M2.1) view, or in the **I/O and Hardware (M5)** menu.

Digital outputs, slot B (Basic)

Table 33: Digital Outputs, Slot B.

Structure	Parameter	Unit	Min	Max	Default	ID	Description
P3.5.3.2.1	RO1 Function		None	Remote Start	Run	11001	See <i>Basic RO Functions Table</i> .
P3.5.3.2.2	RO1 ON Delay	s	0	320	0	11002	Defines the amount of time that will pass before the relay output will energize (ON) after trigger of the RO1 Function (P3.5.3.2.1).
P3.5.3.2.3	RO1 OFF Delay	s	0	320	0	11003	Defines the amount of time that will pass before the relay output will de-energize (OFF) after trigger of the RO1 Function (P3.5.3.2.1).
P3.5.3.2.4	RO2 Function		None	Remote Start	General Fault	11004	See <i>Basic RO Functions Table</i> .
P3.5.3.2.5	RO2 ON Delay	s	0	320	0	11005	Defines the amount of time that will pass before the relay output will energize (ON) after trigger of the RO2 Function (P3.5.3.2.4).
P3.5.3.2.6	RO2 OFF Delay	s	0	320	0	11006	Defines the amount of time that will pass before the relay output will de-energize (OFF) after trigger of the RO2 Function (P3.5.3.2.4).
P3.5.3.2.7	RO3 Function		None	Remote Start	Ready	11007	See <i>Basic RO Functions Table</i> .

Basic RO functions

Table 34: Basic RO Functions.

Selection	Selection name	Description
0	Not used	
1	Ready	The variable frequency drive is ready to operate.
2	Run	The variable frequency drive operates (motor is running).
3	General fault	A fault trip has occurred.
4	General fault inverted	A fault trip has <i>not</i> occurred.
5	General alarm	
6	Reversed	The reverse command has been selected.
7	At speed	The output frequency has reached the set reference.
8	Motor regulator activated	One of the limit regulators (for example, current limit or torque limit) is activated.
9	Preset frequency active	The preset frequency has been selected with digital input.
10	Keypad control active	Keypad control mode selected.
11	I/O control B active	I/O control place B selected.
12	Limit supervision 1	

Selection	Selection name	Description
13	Limit supervision 2	Activates if the signal value falls below or exceeds the set supervision limit (P3.8.3 or P3.8.7) depending on the selected function.
14	Start command active	Start command is active.
15	Reserved	
16	Fire mode ON	
17	RTC timer 1 control	Time channel 1 is used.
18	RTC timer 2 control	Time channel 2 is used.
19	RTC timer 3 control	Time channel 3 is used.
20	FB Control WordB.13	
21	FB Control WordB.14	
22	FB Control WordB.15	
23	PID1 in Sleep mode	
24	Reserved	
25	PID1 supervision limits	PID1 feedback value is beyond supervision limits.
26	PID2 supervision limits	PID2 feedback value is beyond supervision limits.
27	Motor 1 control	Contact control for <i>Multi-pump</i> function.
28	Motor 2 control	Contact control for <i>Multi-pump</i> function.
29	Motor 3 control	Contact control for <i>Multi-pump</i> function.
30	Motor 4 control	Contact control for <i>Multi-pump</i> function.
31	Reserved	(Always open.)
32	Reserved	(Always open.)
33	Reserved	(Always open.)
34	Maintenance warning	
35	Maintenance fault	
36	Thermistor fault	
37	Motor switch	
38	Bypass active	Selects relay output for the Bypass active signal. This signal is on when the drive is in Bypass mode.
39	Bypass running	Selects relay output terminal for Bypass contactor control.
40	Drive active	Selects relay output for the Drive active signal. This signal is on when the drive is in Drive mode.
41	Drive output contactor	Controls the Drives Output contactor.
42	Overload Fault	Selects relay output for the Overload fault signal. This signal is on when the Overload fault is active.
43	Essential Services active	Selects relay output for the Essential services signal.
44	Auto Bypass active	Selects relay output for the Auto Bypass active signal

Selection	Selection name	Description
45	Interlock Proofing	Selects relay output for the Interlock Proofing signal.
46	Interlock Proofed	Selects relay output for the Interlock Proofed signal.
47	Stop Forced	Selects relay output for the Local Stop Forced from keypad signal.
48	Remote Start	Selects relay output for the Remote Start signal

Slot C (M3.5.3.3)

If an expansion I/O board that contains a digital/relay output exists in slot C, then this section will be populated with parameters to represent that I/O.

Table 35: Digital Outputs, Slot C.

Structure	Parameter	Unit	Min	Max	Default	ID	Description
P3.5.3.3.1	RO1 Function		None	Remote Start	None	12001	See <i>Basic RO Functions Table</i> .
P3.5.3.3.2	RO2 Function		None	Remote Start	None	12002	
P3.5.3.3.3	RO3 Function		None	Remote Start	None	12003	
P3.5.3.3.4	RO4 Function		None	Remote Start	None	12004	
P3.5.3.3.5	RO5 Function		None	Remote Start	None	12005	
P3.5.3.3.6	RO6 Function		None	Remote Start	None	12006	

Slot D (M3.5.3.4)

If an expansion I/O board that contains a digital/relay output exists in slot D, then this section will be populated with parameters to represent that I/O.

Table 36: Digital Outputs, Slot D.

Structure	Parameter	Unit	Min	Max	Default	ID	Description
P3.5.3.4.1	RO1 Function		None	Remote Start	None	13001	See <i>Basic RO Functions Table</i> .
P3.5.3.4.2	RO2 Function		None	Remote Start	None	13002	
P3.5.3.4.3	RO3 Function		None	Remote Start	None	13003	
P3.5.3.4.4	RO4 Function		None	Remote Start	None	13004	
P3.5.3.4.5	RO5 Function		None	Remote Start	None	13005	
P3.5.3.4.6	RO6 Function		None	Remote Start	None	13006	

Slot E (M3.5.3.5)

If an expansion I/O board that contains a digital/relay output exists in slot E, then this section will be populated with parameters to represent that I/O.

Table 37: Digital Outputs, Slot E.

Structure	Parameter	Unit	Min	Max	Default	ID	Description
P3.5.3.5.1	RO1 Function		None	Remote Start	None	14001	See <i>Basic RO Functions Table</i> .
P3.5.3.5.2	RO2 Function		None	Remote Start	None	14002	
P3.5.3.5.3	RO3 Function		None	Remote Start	None	14003	
P3.5.3.5.4	RO4 Function		None	Remote Start	None	14004	
P3.5.3.5.5	RO5 Function		None	Remote Start	None	14005	
P3.5.3.5.6	RO6 Function		None	Remote Start	None	14006	

Analog Outputs (M3.5.4)

The analog outputs are very flexible to use. Parameters are functions/features that are connected to the required analog output terminals. The analog outputs are configured by the slot they exist on. If no expansion board exists, then the option does not populate with data.



NOTE:

The status of the Analog Outputs can be monitored in the **Multimonitor (P2.1)** view, or in the **I/O and Hardware (M5)** menu.

Slot A Basic (M3.5.4.1)

Table 38: Analog Outputs, Slot A (Basic).

Structure	Parameter	Unit	Min	Max	Default	ID	Description
P3.5.4.1.1	AO1 Function		0% Test	ProcessDataIn8	Output Frequency	10050	See <i>AO Functions Table</i> .
P3.5.4.1.2	AO1 Filter Time	s	0	300	1	10051	Filter time of analog output signal 0 = No filtering
P3.5.4.1.3	AO1 Min Signal		0 Vdc/0 mA	2 Vdc/4 mA	0 Vdc/0 mA	10052	Settings: 0 = 0 Vdc/0 mA 1 = 2 Vdc/4 mA
P3.5.4.1.4	AO1 MinScale		Varies	Varies	Varies	10053	Min Scale in process unit.
P3.5.4.1.5	AO1 MaxScale		Varies	Varies	Varies	10054	Max Scale in process unit

Table 39: Analog Output Functions.

Settings		Description
0	0% Test	AO is not used. 0 output.
1	100% Test	AO is max. 10 Vdc or 20 mA output.
2	Output Frequency	Track the Output Frequency based on 0 to Max Frequency (P3.3.2) .
3	Freq Reference	Track the Frequency Reference base on 0 to Max Frequency (P3.3.2) .
4	Motor Speed	Track the Motor Speed based on 0 to Motor Nom Speed (P3.1.1.3) .
5	Output Current	Track the Output Current based on 0 to Motor Nom Currnt (P3.1.1.4) .
6	Motor Torque	Track the Motor Torque based on 0 to TnMotor.

Settings		Description
7	Motor Power	Track the Motor Power based on 0 to PnMotor.
8	Motor Voltage	Track the Motor Voltage based on 0 to VnMotor.
9	DC Link Voltage	Track the DC Link Voltage based on 0 - 1000 Vdc.
10	PID 1 Output	Track the PID1 Output based on 0 - 100%
11	PID 2 Output	Track the PID2 Output based on 0 - 100%.
12	Process Data In 1	Track the Process Data In 1 where 5000 = 50.00%.
13	Process Data In 2	Track the Process Data In 2 where 5000 = 50.00%.
14	Process Data In 3	Track the Process Data In 3 where 5000 = 50.00%.
15	Process Data In 4	Track the Process Data In 4 where 5000 = 50.00%.
16	Process Data In 5	Track the Process Data In 5 where 5000 = 50.00%.
17	Process Data In 6	Track the Process Data In 6 where 5000 = 50.00%.
18	Process Data In 7	Track the Process Data In 7 where 5000 = 50.00%.
19	Process Data In 8	Track the Process Data In 8 where 5000 = 50.00%.

Slot C (M3.5.4.3)

If an expansion I/O board that contains an analog output exists in slot C, then this section will be populated with parameters to represent that I/O.

Table 40: Analog Outputs, Slot C.

Structure	Parameter	Unit	Min	Max	Default	ID	Description
P3.5.4.3.1	AO1 Function		0% Test	ProcessDataIn8	0% Test	12050	See <i>AO Functions Table</i> .
P3.5.4.3.2	AO1 Filter Time	s	0	300	1	12051	Filter time of analog output signal 0 = No filtering
P3.5.4.3.3	AO1 Min Signal		0 Vdc/0 mA	2 Vdc/4 mA	0 Vdc/0 mA	12052	Settings: 0 = 0 Vdc/0 mA 1 = 2 Vdc/4 mA
P3.5.4.3.4	AO1 MinScale		Varies	Varies	Varies	12053	Min Scale in process unit.
P3.5.4.3.5	AO1 MaxScale		Varies	Varies	Varies	12054	Max Scale in process unit
P3.5.4.3.6	AO2 Function		0% Test	ProcessDataIn8	0% Test	12055	See <i>AO Functions Table</i> .
P3.5.4.3.7	AO2 Filter Time	s	0	300	1	12056	Filter time of analog output signal 0 = No filtering
P3.5.4.3.8	AO2 Min Signal		0 Vdc/0 mA	2 Vdc/4 mA	0 Vdc/0 mA	12057	Settings: 0 = 0 Vdc/0 mA 1 = 2 Vdc/4 mA
P3.5.4.3.9	AO2 MinScale		Varies	Varies	Varies	12058	Min Scale in process unit.
P3.5.4.3.10	AO2 MaxScale		Varies	Varies	Varies	12059	Max Scale in process unit

Slot D (M3.5.4.4)

If an expansion I/O board that contains an analog output exists in slot C, then this section will be populated with parameters to represent that I/O.

Table 41: Analog Outputs, Slot D.

Structure	Parameter	Unit	Min	Max	Default	ID	Structure
P3.5.4.4.1	AO1 Function		0% Test	ProcessDataIn8	0% Test	13050	See <i>AO Functions Table</i> .
P3.5.4.4.2	AO1 Filter Time	s	0	300	1	13051	Filter time of analog output signal 0 = No filtering
P3.5.4.4.3	AO1 Min Signal		0 Vdc/0 mA	2 Vdc/4 mA	0 Vdc/0 mA	13052	Settings: 0 = 0 Vdc/0 mA 1 = 2 Vdc/4 mA
P3.5.4.4.4	AO1 MinScale		Varies	Varies	Varies	13053	Min Scale in process unit.
P3.5.4.4.5	AO1 MaxScale		Varies	Varies	Varies	13054	Max Scale in process unit
P3.5.4.4.6	AO2 Function		0% Test	ProcessDataIn8	0% Test	13055	See <i>AO Functions Table</i> .
P3.5.4.4.7	AO2 Filter Time	s	0	300	1	13056	Filter time of analog output signal 0 = No filtering
P3.5.4.4.8	AO2 Min Signal		2 Vdc/0 mA	2 Vdc/4 mA	0 Vdc/0 mA	13057	Settings: 0 = 0 Vdc/0 mA 1 = 2 Vdc/4 mA
P3.5.4.4.9	AO2 MinScale		Varies	Varies	Varies	13058	Min Scale in process unit.
P3.5.4.4.10	AO2 MaxScale		Varies	Varies	Varies	13059	Max Scale in process unit

Slot E (M3.5.4.5)

If an expansion I/O board that contains an analog output exists in slot C, then this section will be populated with parameters to represent that I/O.

Table 42: Analog Outputs, Slot E.

Structure	Parameter	Unit	Min	Max	Default	ID	Description
P3.5.4.5.1	AO1 Function		0% Test	ProcessDataIn8	0% Test	14050	See Table <i>AO Functions</i> .
P3.5.4.5.2	AO1 Filter Time	s	0	300	1	14051	Filter time of analog output signal 0 = No filtering
P3.5.4.5.3	AO1 Min Signal		0 Vdc/0 mA	2 Vdc/4 mA	0 Vdc/0 mA	14052	Settings: 0 = 0 Vdc/0 mA 1 = 2 Vdc/4 mA
P3.5.4.5.4	AO1 MinScale		Varies	Varies	Varies	14053	Min Scale in process unit.
P3.5.4.5.5	AO1 MaxScale		Varies	Varies	Varies	14054	Max Scale in process unit
P3.5.4.5.6	AO2 Function		0% Test	ProcessDataIn8	0% Test	14055	See Table <i>AO Functions</i> .
P3.5.4.5.7	AO2 Filter Time	s	0	300	1	14056	Filter time of analog output signal 0 = No filtering
P3.5.4.5.8	AO2 Min Signal		0 Vdc/0 mA	2 Vdc/4 mA	0 Vdc/0 mA	14057	Settings: 0 = 0 Vdc/0 mA 1 = 2 Vdc/4 mA
P3.5.4.5.9	AO2 MinScale		Varies	Varies	Varies	14058	Min Scale in process unit.
P3.5.4.5.10	AO2 MaxScale		Varies	Varies	Varies	14059	Max Scale in process unit

Fieldbus Data Mapping (M3.6)

Fieldbus data In/Out mappings provide further information over the fieldbus that is not available in the current object mappings. Data sent to the fieldbus can be chosen with a parameter ID number, and the data is scaled to an unsigned 16-bit format according to the format on the keypad. For example, 25.5 on the keypad becomes 255 over the fieldbus data mapping.

The fieldbus data mapping settings are presented in the following table:

Table 43: Fieldbus Data Mapping Settings.

Structure	Parameter	Unit	Min	Max	Default	ID	Description
P3.6.1	FB DataOut 1 Sel		0	35000	Output Frequency (1)	852	Defines the data to be sent to the fieldbus as FB DataOut 1. This is chosen with the parameter ID. The data is scaled to unsigned 16-bit format according to the format on the keypad. For example, this parameter is set to a value of 1 which is Output Frequency (P2.2.1) ID 1. If the keypad is displaying 25.5 Hz, then the data over the FB will be 255. BACnet = AV_20 P1 = Subpoint 50
P3.6.2	FB DataOut 2 Sel		0	35000	Motor Speed (2)	853	Defines the data to be sent to the fieldbus as FB DataOut 2. See FBDataOut 1 Sel (P3.6.1) for further details. BACnet = AV_21 P1 = Subpoint 51
P3.6.3	FB DataOut 3 Sel		0	35000	Current (45)	854	Defines the data to be sent to the fieldbus as FB DataOut 3. Refer to FBDataOut 1 Sel (P3.6.1) for further details. BACnet = AV_22 P1 = Subpoint 52
P3.6.4	FB DataOut 4 Sel		0	35000	Torque (4)	855	Defines the data to be sent to the fieldbus as FB DataOut 4. See FBDataOut 1 Sel (P3.6.1) for further details. BACnet = AV_23 P1 = Subpoint 53
P3.6.5	FB DataOut 5 Sel		0	35000	Power (5)	856	Defines the data to be sent to the fieldbus as FB DataOut 5. Refer to FBDataOut 1 Sel (P3.6.1) for further details. BACnet = AV_24 P1 = Subpoint 54

Structure	Parameter	Unit	Min	Max	Default	ID	Description
P3.6.6	FB DataOut 6 Sel		0	35000	Voltage (6)	857	Defines the data to be sent to the fieldbus as FB DataOut 6. See FBDataOut 1 Sel (P3.6.1) for further details. BACnet = AV_25 P1 = Subpoint 55
P3.6.7	FB DataOut 7 Sel		0	35000	DC Link (7)	858	Defines the data to be sent to the fieldbus as FB DataOut 7. See FBDataOut 1 Sel (P3.6.1) for further details. BACnet = AV_26 P1 = Subpoint 56

Structure	Parameter	Unit	Min	Max	Default	ID	Description
P3.6.8	FB DataOut 8 Sel		0	35000	Last Fault (37)	859	Defines the data to be sent to the fieldbus as FB DataOut 8. See FBDataOut 1 Sel (P3.6.1) for further details. BACnet = AV_27 P1 = Subpoint 57
P3.6.9	FB Run Enable		Disabled	Enabled	Enabled	1829	Defines the run enable when in fieldbus control. NOTE: When fieldbus is not in use, see Run Enable (P3.5.1.11)

For example, to provide the PID1 Feedback over the fieldbus. Complete the following:

Set Fieldbus Data Out 1 Selection (P3.6.1) can be set to a value of 21 [which represents **PID Feedback** (P2.4.2)].

Prohibited Frequencies (M3.7)

In some systems it may be necessary to avoid certain frequencies due to mechanical resonance problems. By setting up prohibited frequencies, these ranges are skipped.

The prohibited frequencies settings are presented in the following table:

Table 44: Prohibited Frequencies Settings.

Structure	Parameter	Unit	Min	Max	Default	ID	Description
P3.7.1	Range 1 Low Lim	Hz	0	320	0	509	Defines the low limit of the first prohibited frequency. The drive will change its accel/decel time by the RampTimeFactor (P3.7.7) while within the range of this low limit and the Range 1 High Lim (P3.7.2). NOTE: The drive will not control within these ranges, it will either be faster or slower, but never within the range defined.
P3.7.2	Range 1 High Lim	Hz	0	320	0	510	Defines the high limit of the first prohibited frequency. The drive will change its accel/decel time by the RampTimeFactor (P3.7.7) while within the range of this high limit and the Range 1 Low Lim (P3.7.1). NOTE: The drive will not control within these ranges; it will either be faster or slower, but never within the range defined.
P3.7.3	Range 2 Low Lim	Hz	0	320	0	511	Defines the low limit of the second prohibited frequency. See Range 1 Low Lim (P3.7.1) for further details.
P3.7.4	Range 2 High Lim	Hz	0	320	0	512	Defines the high limit of the second prohibited frequency. See Range 1 High Lim (P3.7.2) for further details.
P3.7.5	Range 3 Low Lim	Hz	0	320	0	513	Defines the low limit of the third prohibited frequency. See Range 1 Low Lim (P3.7.1) for further details.
P3.7.6	Range 3 High Lim	Hz	0	320	0	514	Defines the high limit of the third prohibited frequency. See Range 1 High Lim (P3.7.2) for further details.
P3.7.7	RampTimeFactor		0.1	10	1	518	Defines the multiplier of the currently selected ramp time (accel time 1/2 and decel time 1/2) between the prohibited frequency limits.

Example:

A resonance noise is occurring on an air handling unit when the drive speed is around 75% (45 Hz). Complete the following:

1. Set **Prohibited Frequency Range 1 Low Limit** (P3.7.1) to a value of **44.5**.
2. Set **Prohibited Frequency Range 1 High Limit** (P3.7.2) to a value of **45.5**.

**NOTE:**

The drive will still ramp through these speeds, but will not control within this range. The speed at which the drive ramps through this range can be changed by the **Ramp Time Factor** (P3.7.7) to make it faster.

For example. If **Acceleration Time 1** (P3.4.2) is set to a value of 120, **Minimum Frequency** (P3.3.1) is set to a value of 0, and **Maximum Frequency** (P3.3.2) is set to a value of 60; then it takes 2 seconds to speed up 1 hertz. If **Ramp Time Factor** (P3.7.7) is set to a value of 2, then it takes 1 second to speed up 1 hertz when within the range as defined by **Prohibited Frequency Range 1 Low Limit** (P3.7.1) and **Prohibited Frequency Range 1 High Limit** (P3.7.2)

Limit supervisions (M3.8)

Two signal values can be selected for supervision. High or low limits are supervised.

The limit supervisions settings are presented in the following table:

Table 45: Limit Supervisions Settings.

Structure	Parameter	Unit	Min	Max	Default	ID	Description
P3.8.1	Superv1 Item		Output Frequency	Analog Input 2	Output Frequency	1431	Defines the drive data to supervise for Superv1 Mode (P3.8.2) in accordance with the Superv1 Limit (P3.8.3) with deadband defined with Superv1 Hyst (P3.8.4) 0 = Output Frequency 1 = Frequency Reference 2 = Motor Current 3 = Motor Torque 4 = Motor Power 5 = DC-Link Voltage 6 = Analog Input 1 7 = Analog Input 2 NOTE: A relay output can be triggered in accordance with this supervised item. Set Relay Output Function to a value of Superv1 Lmt.
P3.8.2	Superv1 Mode		Not Used	High Limit	Not Used	1432	Defines the type of supervision of the Superv1 Item (P3.8.1) in accordance with the Superv1 Limit (P3.8.3) with deadband defined with Superv1 Hyst (P3.8.4) 0 = Not used 1 = Low Limit Supervision 2 = High Limit Supervision
P3.8.3	Superv1 Limit	Varies	-200	200	25	1433	Defines the limit that Superv1 Item (P3.8.1) is compared to, which determines if Superv1 Mode (P3.8.2) has occurred. Unit of measure displays automatically.
P3.8.4	Superv1 Hyst	Varies	-200	200	5	1434	Defines the deadband of Superv1 Item (P3.8.1).

Structure	Parameter	Unit	Min	Max	Default	ID	Description
P3.8.5	Superv2 Item		Output Frequency	Analog Input 2	Output Frequency	1435	Defines the drive data to supervise for Superv2 Mode (P3.8.6) in accordance with the Superv2 Limit (P3.8.7) with deadband defined with Superv2 Hyst (P3.8.8) Refer to <i>Superv1 Item</i> (P3.8.1) for settings. NOTE: A relay output can be triggered in accordance with this supervised item. Set Relay Output Function to a value of <i>Superv2 Lmt</i> .
P3.8.6	Superv2 Mode		Not Used	High Limit	Not Used	1436	Defines the type of supervision of the Superv2 Item (P3.8.5) in accordance with the Superv2 Limit (P3.8.7) with deadband defined with Superv2 Hyst (P3.8.8) 0 = Not used 1 = Low Limit Supervision 2 = High Limit Supervision
P3.8.7	Superv2 Limit	Varies	-200	200	25	1437	Defines the limit that Superv2 Item (P2.8.5) is compared to, which determines if Superv2 Mode (P3.8.6) has occurred. Unit of measure appears automatically.
P3.8.8	Superv2 Hyst	Varies	-200	200	5	1438	Defines the deadband of Superv1 Item (P3.8.5).

Example:

To energize relay output 1 when the motor output current has reached 4 amps and have the drive act like a current transducer (CT). Complete the following:

1. Set **Supervision Item 1 Selection** (P3.8.1) to a value of **Motor Current**.
2. Set **Supervision Item 1 Mode** (P3.8.2) to a value of **High Limit**.
3. Set **Supervision Item 1 Limit** (P3.8.3) to a value of **4**.
4. Set **RO1 Function** (P3.5.3.2.1) to a value of **LimSuperv1**.

Protections (M3.9)

Protections define the way the drive is to respond to conditions that can occur in the drive.

Table 46: Protections Settings.

Structure	Parameter	Unit	Min	Max	Default	ID	Description
P3.9.1	AI Low Fault		No Action	Fault, Coast	No Action	700	Defines the response to a low analog input signal. Response settings are as follows: 0 = No Action 1 = Alarm 2 = Alarm and run to PresetAlarmFreq (P3.3.19) 3 = Fault (<i>stop according to stop mode</i>) 4 = Fault (<i>stop by coasting</i>)
P3.9.2	External Fault		No Action	Fault, Coast	Fault	701	Defines the response to activation of an Ext Fault Close (P3.5.1.7) or Ext Fault Open (P3.5.1.8). Response settings are as follows: 0 = No Action 1 = Alarm 2 = Fault (<i>stop according to stop mode</i>) 3 = Fault (<i>stop by coasting</i>)
P3.9.3	InputPhaseFault		3-phase	1-phase	3-phase	730	Defines the input phase support. 0 = 3-phase support 1 = 1-phase support NOTE: If single phase supply is used, 1-phase support must be selected.
P3.9.4	Undervoltage Flt		Fault Stored	No History	Fault Stored	727	Defines if the under-voltage fault is stored in the fault history or not. 0 = Fault Stored 1 = No History
P3.9.5	OutputPhase Flt		No Action	Fault, Coast	Fault	702	Defines the response to an output phase loss. Response settings are as follows: 0 = No Action 1 = Alarm 2 = Fault (<i>stop according to stop mode</i>) 3 = Fault (<i>stop by coasting</i>)
P3.9.6	Motor Therm Prot		No Action	Fault, Coast	Fault	704	Defines the response to a motor thermal protection. Response settings are as follows: 0 = No Action 1 = Alarm 2 = Fault (<i>stop according to stop mode</i>) 3 = Fault (<i>stop by coasting</i>)
P3.9.7	MotAmbient Temp	°F	-4	212	104	705	Defines the ambient temperature that is to generate a response to a Motor Thermal Protection fault as defined by Motor Therm Prot (P3.9.6).
P3.9.8	ZeroSpeedCooling	%	5	150	60	706	Defines the cooling factor at zero speed in relation to the point where the motor is running at nominal speed without external cooling.
P3.9.9	ThermTimeConst	min	1	200	Varies	707	The time constant is the time within which the calculated thermal stage has reached 63% of its final value.

Structure	Parameter	Unit	Min	Max	Default	ID	Description
P3.9.10	MotThermLoadbil	%	0	150	100	708	Motor thermal loadability states how much the motor can be thermally loaded.
P3.9.11	MotorStall Flt		0	3	0	709	Defines the response to a motor stall. Response settings are as follows: 0 = No Action 1 = Alarm 2 = Fault (<i>stop according to stop mode</i>) 3 = Fault (<i>stop by coasting</i>)
P3.9.12	Stall Current	A	0	2*I _H	I _H	710	For a stall stage to occur, the current must have exceeded this limit.
P3.9.13	Stall Time Limit	s	1	120	15	711	This is the maximum time allowed for a stall stage.
P3.9.14	Stall Freq.Limit	Hz	1	Parameter P1.9 or P3.3.2	25	712	For a stall stage to occur, the output frequency must have remained below this limit for a certain time.
P3.9.15	Underload Flt		0	3	0	713	Defines the response to an underload. Response settings are as follows: 0 = No Action 1 = Alarm 2 = Fault (<i>stop according to stop mode</i>) 3 = Fault (<i>stop by coasting</i>)
P3.9.16	UL FieldweakLoad	%	10	150	50	714	This parameter gives the value for the min torque allowed when the output frequency is above the field weakening point.
P3.9.17	UL ZeroFreq.Load	%	5	150	10	715	This parameter gives the value for the min torque allowed with zero frequency.
P3.9.18	UL Time Limit	s	2	600	20	716	This is the maximum time allowed for an underload state to exist.
P3.9.19	FieldbusComm Flt		No Action	4	Fault	733	Defines the response to a fieldbus communications signal loss. Response settings are as follows: 0 = No Action 1 = Alarm 2 = Alarm and run to PresetAlarmFreq (P3.3.19) 3 = Fault (<i>stop according to stop mode</i>) 4 = Fault (<i>stop by coasting</i>)
P3.9.20	SlotComm Flt		No Action	Fault, Coast	Fault	734	Defines the response to an option card slot communications failure. Response settings are as follows: 0 = No Action 1 = Alarm 2 = Fault (<i>stop according to stop mode</i>) 3 = Fault (<i>stop by coasting</i>)
P3.9.21	Thermistor Fault		No Action	Fault, Coast	No Action	732	Defines the response to a thermistor failure. Response settings are as follows: 0 = No Action 1 = Alarm 2 = Fault (<i>stop according to stop mode</i>) 3 = Fault (<i>stop by coasting</i>) NOTE: It is recommend to set to a value of Fault (<i>according to stop mode</i>) if a BT300-OPT-B4-V option card is installed.

Structure	Parameter	Unit	Min	Max	Default	ID	Description
P3.9.22	PID1 Supervision		No Action	Fault, Coast	Fault	749	Defines the response to a PID1 fault. Response settings are as follows: 0 = No Action 1 = Alarm 2 = Fault (<i>stop according to stop mode</i>) 3 = Fault (<i>stop by coasting</i>)
P3.9.23	PID2 Supervision		No Action	Fault, Coast	Fault	757	Defines the response to a PID2 fault. Response settings are as follows: 0 = No Action 1 = Alarm 2 = Fault (<i>stop according to stop mode</i>) 3 = Fault (<i>stop by coasting</i>)
P3.9.25	TempFault Signal		Not Used	TempInput1 -3	Not Used	739	Defines the source signal to monitor for TempAlarm Limit (P3.9.26) and TempFault Limit (P3.9.27) triggering. Settings: 0 = Not used 1 = Temperature Input 1 2 = Temperature Input 2 3 = Temperature Input 3 4 = Temperature Inputs 1 & 2 5 = Temperature Inputs 2 & 3 6 = Temperature Inputs 1 & 3
P3.9.26	TempAlarm Limit		-30	200	130	741	Defines the temperature that TempFault Signal (P3.9.25) must reach for triggering an alarm.
P3.9.27	TempFault Limit		-30	200	155	742	Defines the temperature that TempFault Signal (P3.9.25) must reach for triggering a fault.
P3.9.28	TempFault Response		No Action	Fault, Coast	Fault	740	Defines the response action when TempFault Signal (P3.9.25) has past TempFault Limit (P3.9.27). Response settings are as follows: 0 = No Action 1 = Alarm 2 = Fault (<i>stop according to stop mode</i>) 3 = Fault (<i>stop by coasting</i>)
P3.9.29	Run Interlock Flt		No Action	Fault, Coast	No Action	14061	Defines the response action to a Run Interlock Fault. This requires Mot. Interlock Start (P3.2.11) to be enabled, Run Interlock 1 (P3.5.1.12) or Run Interlock 2 (P3.5.1.13) to be defined to a digital input and a value defined for Run Interlock Proof (P3.2.13) other than 0.

Response to external fault (P3.9.2)

An alarm message or a fault action and message is generated by an external fault signal in one of the programmable digital inputs (DI3 by default) using parameters **Ex Fault Close** (P3.5.1.7) and **Ex Fault Open** (P3.5.1.8). The information can also be programmed into any of the relay outputs.

Motor thermal protection (P3.9.6 through P3.9.10)

The motor thermal protection protects the motor from overheating. The drive is capable of supplying higher than nominal current to the motor. If the load requires this high current, there is a risk that the motor will thermally overload. This commonly happens at low frequencies. At low frequencies, the cooling effect of the

motor is reduced as well as its capacity. If the motor is equipped with an external fan, the load reduction at low speeds is small.

The motor thermal protection is based on a calculated model and uses the output current of the drive to determine the load on the motor. The motor thermal protection can be adjusted with parameters. The thermal current I_T specifies the load current above which the motor is overloaded. This current limit is a function of the output frequency.

The thermal stage of the motor can be monitored on the keypad display.

**NOTE:**

The calculated model does not protect the motor if the airflow to the motor is reduced by a blocked air intake grill. The model starts from zero if the control board is powered off

Motor thermal zero speed cooling (P3.9.8)

Defines the cooling factor at zero speed in relation to the point where the motor is running at nominal speed without external cooling. See the Table *Protections Settings* in the *Protections (M3.9)* section.

The default value is set assuming that there is no external fan cooling the motor. If an external fan is used this parameter can be set to 90% (or even higher).

If you change **Motor nominal current** (P3.1.1.4), this parameter is automatically restored to the default value.

Setting this parameter does not affect the maximum output current of the drive which is determined by **Current Limit** (P3.1.1.7) alone.

The corner frequency for the thermal protection is 70% of the **Motor nominal frequency** (P3.1.1.2).

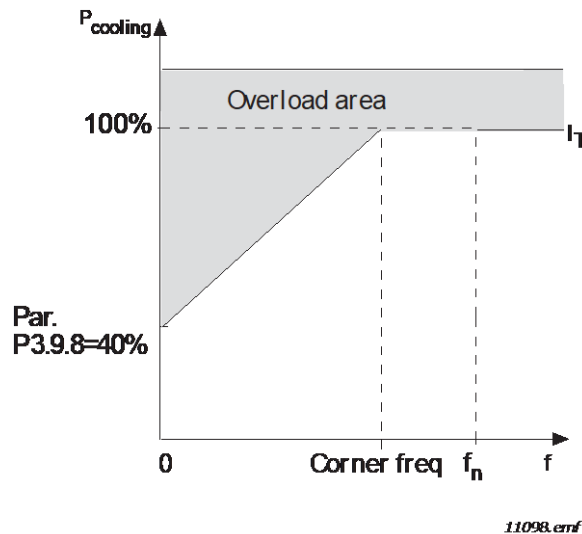

Figure 18: Motor thermal current I_T curve.

Motor thermal time constant (P3.9.9)

The time constant is the time within which the calculated thermal stage has reached 63% of its final value. The bigger the frame and/or the slower the speed of the motor, the longer the time constant.

The motor thermal time is specific to the motor design and it varies between different motor manufacturers. The default value of the parameter varies from size to size.

If the motor's t_6 -time (t_6 is the time in seconds the motor can safely operate at six times the rated current) is known (given by the motor manufacturer), the time constant parameter can be set based on it. As a rule of thumb, the motor thermal time constant in minutes is equal to $2 \cdot t_6$. If the drive is in stop stage, the time constant is internally increased to three times the set parameter value. The cooling in stop stage is based on convection and the time constant is increased. See Figure *Motor Temperature Calculation*.

Motor thermal load (P3.9.10)

Setting the value to 130% means that the nominal temperature will be reached with 130% of the motor's nominal current.

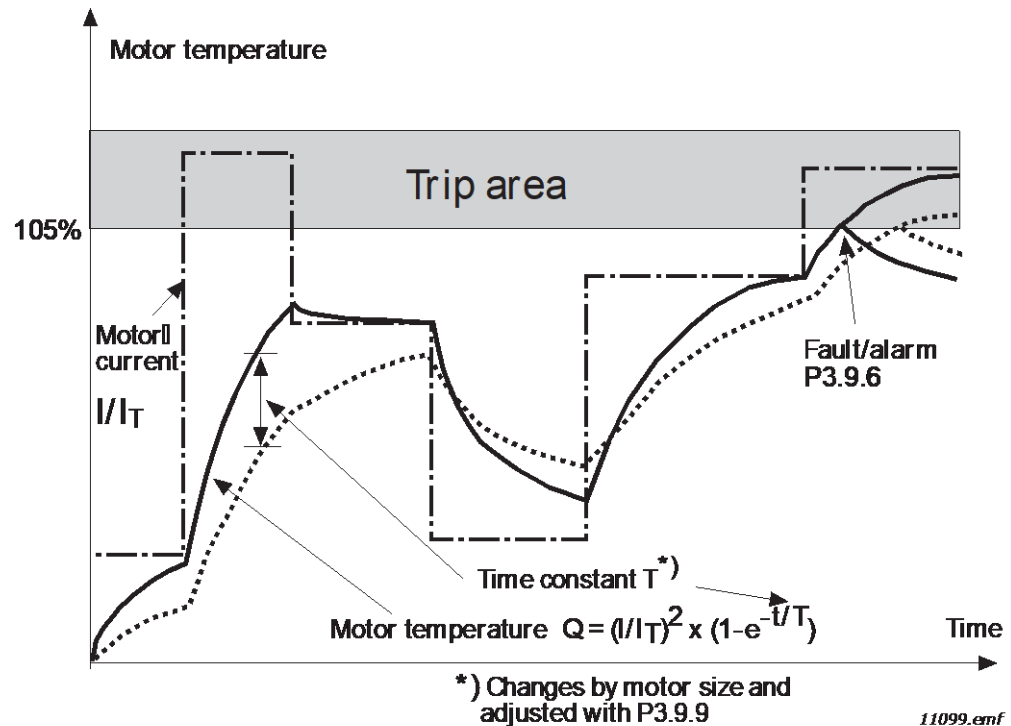

Figure 19: Motor Temperature Calculation.

Stall Protection (P3.9.11 through P3.9.14)

The motor stall protection protects the motor from short-time overload situations such as one caused by a stalled shaft. The reaction time of the stall protection can be set shorter than that of the motor thermal protection. The stall state is defined with two parameters: **Stall Current** (P3.9.12) and **Stall Frequency Limit** (P3.9.14). If the current is higher than the set limit and the output frequency is lower than the set limit, the stall state is true. There is actually no real indication of the shaft rotation. Stall protection is a type of over-current protection.

Stall current (P3.9.12)

The current can be set to $0.0 \dots 2 \cdot I_L$. For a stall stage to occur, the current must have exceeded this limit. See the following figure. If **Motor current limit** (P3.1.1.7) is changed, this parameter is automatically calculated to 90% of the current limit.



NOTE:

To guarantee desired operation, this limit must be set below the current limit.

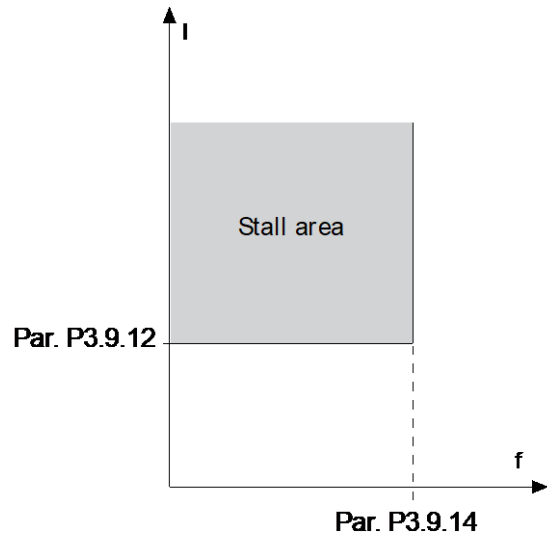

11100.emf

Figure 20: Stall characteristics settings.

Stall time limit (P3.9.13)

This time can be set between 1.0 and 120.0s.

This is the maximum time allowed for a stall stage. The stall time is counted by an internal up/down counter. If the stall time counter value goes above this limit, the protection will cause a trip (see *Parameters of Stall Protection* [P3.9.11]).

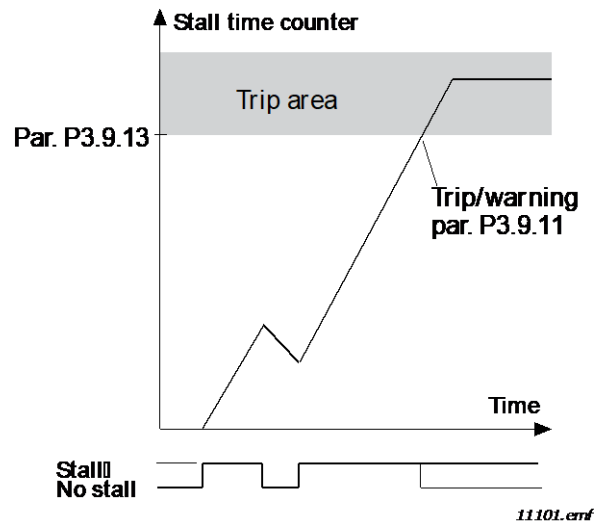

11101.emf

Figure 21: Stall time count.

Under-load protection (P3.9.15 through P3.9.18)

The motor under-load protection ensures that there is load on the motor when the drive is running. If the motor loses its load, there might be a problem in the process (for example, a broken belt or a dry pump).

Motor under-load protection can be adjusted by setting the under-load curve **with Field Weakening Area Load** (P3.9.16) and **Zero Frequency Load** (P3.9.17). The under-load curve is a squared curve set between the zero frequency and the field weakening point. The protection is not active below 5 Hz (the under-load time counter is stopped).

The torque values for setting the under-load curve are set in percentage which refers to the nominal torque of the motor. The motor's name plate data, parameter motor nominal current and drives nominal current IL are used to find the scaling ratio for the internal torque value. If other than a nominal motor is used with the drive, the accuracy of the torque calculation decreases.

Under-load protection: Field weakening area load (P3.9.16)

The torque limit can be set between 10.0 and $150.0\% \times T_n$ Motor.

This parameter gives the value for the minimum torque allowed when the output frequency is above the field weakening point. See the following figure.

If you change **Motor Nom Currnt** (P3.1.1.4), this parameter is automatically restored to the default value.

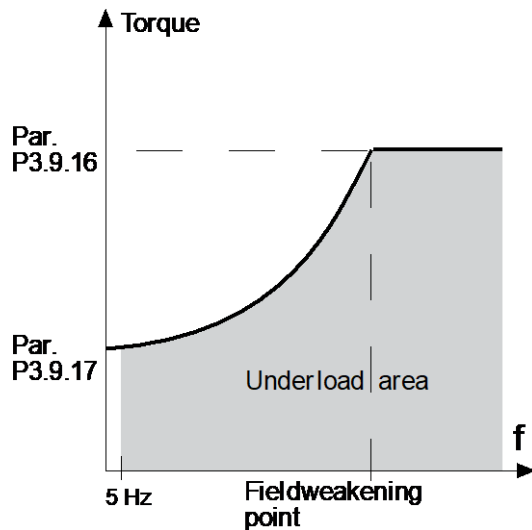

11102.enf

Figure 22: Setting of minimum load.

Under-load protection: Time limit (P3.9.18)

This time can be set between 2.0 and 600.0 s.

This is the maximum time allowed for an under-load state to exist. An internal up/down counter counts the accumulated under-load time. If the under-load counter value goes above this limit the protection will cause a trip according to **Underload Flt** (P3.9.15). If the drive is stopped the under-load counter is reset to zero.

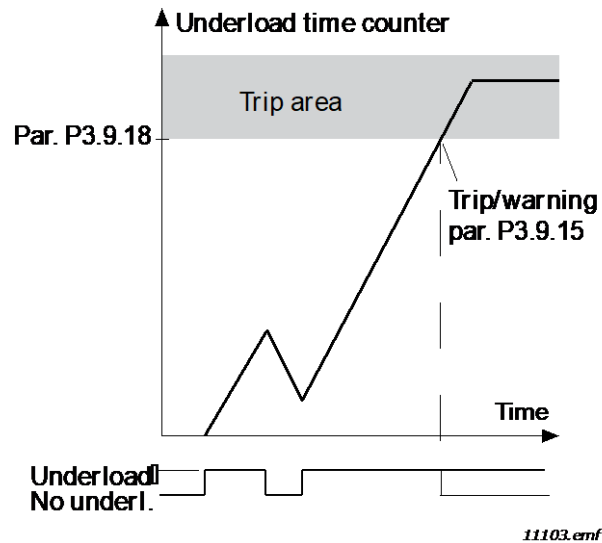

Figure 23: Underload time counter function.

Automatic Reset (M3.10)

The Automatic Reset settings define how the automatic reset feature operates as well as what faults are allowed to be reset automatically.

The automatic reset settings are presented in the following table:

Structure	Parameter	Unit	Min	Max	Default	ID	Description
P3.10.1	Automatic Reset		Disabled	Enabled	Disabled	731	Determines if the Automatic Reset feature can be used.
P3.10.2	Restart Function		Flying Start	Start Function	Start Function	719	Start mode for Automatic Reset activation: 0 = Flying Start 1 = According to Start Function (P3.2.4)
P3.10.3	Wait Time	s	0.1	10000	30	717	Wait time before first reset is executed.
P3.10.4	Trial Time	s	0	10000	330	718	When the trial time has elapsed, and the fault is still active, the drive will trip on fault.
P3.10.5	Number of Trials		1	10	10	759	Number of restart attempts (irrespective of fault type).
P3.10.6	Undervoltage Flt		No	Yes	Yes	720	Determines if the automatic reset feature can reset when an undervoltage fault condition occurs.
P3.10.7	OverVoltage Flt		No	Yes	Yes	721	Determines if the automatic reset feature can reset when an overvoltage fault condition occurs.
P3.10.8	OverCurrent Flt		No	Yes	Yes	722	Determines if the automatic reset feature can reset when an overcurrent fault condition occurs.
P3.10.9	AI Low Fault		No	Yes	Yes	723	Determines if the automatic reset feature can reset when an analog input low signal condition occurs.

Structure	Parameter	Unit	Min	Max	Default	ID	Description
P3.10.10	UnitOverTemp Flt		No	Yes	Yes	724	Determines if the automatic reset feature can reset when a unit over temperature fault condition occurs.
P3.10.11	MotorOverTempFlt		No	Yes	Yes	725	Determines if the automatic reset feature can reset when a motor over temperature fault condition occurs.
P3.10.12	External Fault		No	Yes	No	726	Determines if the Automatic Reset feature can reset when this fault occurs.
P3.10.13	Underload Flt		No	Yes	No	738	Determines if the Automatic Reset feature can reset when this fault occurs.
P3.10.14	Rem Safety Flt		No	Yes	No	728	Determines if the Automatic Reset feature can reset when this fault occurs.
P3.10.15	Run Interlock Flt		No	Yes	No	14062	Determines if the Automatic Reset feature can reset when this fault occurs.

Automatic reset (P3.10.1)

Activate the *Automatic reset* after fault with this parameter.



NOTE:

Automatic reset is allowed for certain faults only. By giving the parameters **Undervoltage flt** (P3.10.6) to **Wait Time** (P3.10.13) the value **0** or **1** you can either allow or deny the automatic reset after the respective faults.

Wait time (P3.10.3), Trial time (P3.10.4), and Number of trials (P3.10.5)

The Automatic reset function keeps resetting the faults appearing during the time set with this parameter. If the number of faults during the trial time exceeds the value of **Number of Trials** (P3.10.5), a permanent fault is generated. Otherwise, the fault is cleared after the trial time has elapsed and the next fault starts the trial time count again.

Number of Trials (P3.10.5) determines the maximum number of automatic fault reset attempts during the trial time set by this parameter. The time count starts from the first auto-reset. The maximum number is independent of the fault type.

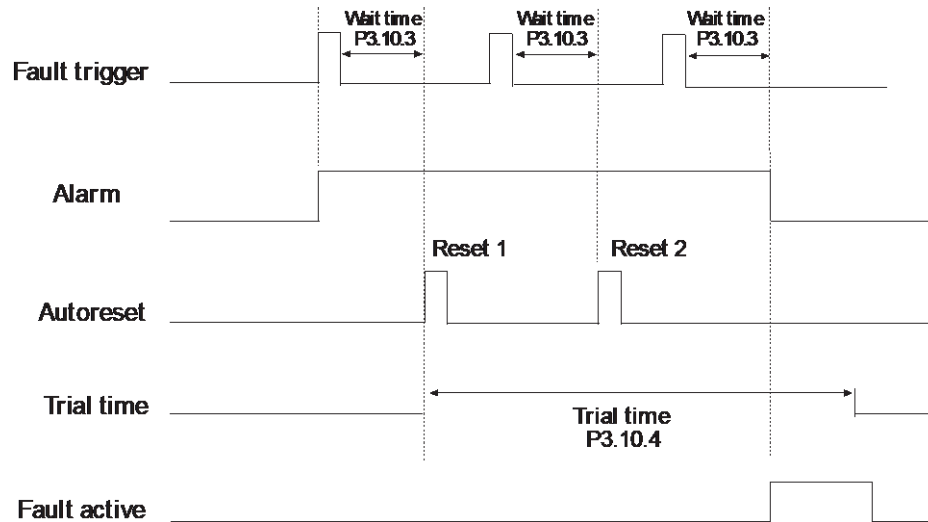

Number of trials: (P3.10.5 = 2)

11104.emf

Figure 24: Automatic reset function.

Timer Functions (M3.11)

The timer functions (time channels) in the BT300 drive allow you to program functions to be controlled by the internal RTC (Real Time Clock). Almost every function that can be controlled by a digital input can also be controlled by a time channel. Instead of having an external PLC or Field Panel controlling a digital input, you can internally program the closed and opened intervals of the input.

Time Channels

The on/off logic for the time channels is configured by assigning intervals and/or timers to them. One time channel can be controlled by many intervals or timers by assigning as many of these as needed to the time channel.

Intervals

Every interval is given an **ON Time** and **OFF Time**. This is the daily time that the interval will be active during the days set with **From Day** and **To Day**. For example, the settings below indicate that the interval is active from 7:00 A.M. to 9:00 A.M. every weekday (Monday through Friday). The time channel this interval is assigned to will be seen as a closed virtual digital input during that period.

ON Time: 07:00:00

OFF Time: 09:00:00

From Day: Monday

To Day: Friday

Interval 1 (M3.11.1)

Table 47: Interval 1.

Structure	Parameter	Unit	Min	Max	Default	ID	Description
P3.11.1.1	ON Time	hh:mm:ss	0:00:00	23:59:59	1464	ON Time	Defines the time ON is issued to the time the channel defined in AssignToChannel (P3.11.1.5) on the day of week defined in From Day (P3.11.1.3) to and including day defined in To Day (P3.11.1.4).
P3.11.1.2	OFF Time	hh:mm:ss	0:00:00	23:59:59	1465	OFF Time	Defines the time OFF is issued to the time channel defined in AssignToChannel (P3.11.1.5) on the day of week defined in From Day (P3.11.1.3) to and including day defined in To Day (P3.11.1.4).
P3.11.1.3	From Day		Sunday	Saturday	1466	From Day	Defines the beginning day of the week the ON Time (P3.11.1.1) and OFF Time (P3.11.1.2) are issued to the unit. 0 = Sunday 1 = Monday 2 = Tuesday 3 = Wednesday 4 = Thursday 5 = Friday 6 = Saturday
P3.11.1.4	To Day		Sunday	Saturday	1467	To Day	Defines the ending day of the week the ON Time (P3.11.1.1) and OFF Time (P3.11.1.2) are issued to the unit. 0 = Sunday 1 = Monday 2 = Tuesday 3 = Wednesday 4 = Thursday 5 = Friday 6 = Saturday
P3.11.1.5	AssignToChannel		Not Used	Time Channel 3	1468	AssignToChannel	Defines the affected time channel of the ON Time (P3.11.1.1) and OFF Time (P3.11.1.2) 0 = Not used 1 = Time Channel 1 2 = Time Channel 2 3 = Time Channel 3

Interval 2 (M3.11.2)

Table 48: Interval 2.

Structure	Parameter	Unit	Min	Max	Default	ID	Description
P3.11.2.1	ON Time	hh:mm:ss	0:00:00	23:59:59	0:00:00	1469	See description for P3.11.1.1
P3.11.2.2	OFF Time	hh:mm:ss	0:00:00	23:59:59	0:00:00	1470	See description for P3.11.1.2
P3.11.2.3	From Day		Sunday	Saturday	Sunday	1471	See description for P3.11.1.3
P3.11.2.4	To Day		Sunday	Saturday	Sunday	1472	See description for P3.11.1.4
P3.11.2.5	AssignToChannel		Not Used	Time Channel 3	Not Used	1473	See description for P3.11.1.5

Interval 3 (M3.11.3)

Table 49: Interval 3.

Structure	Parameter	Unit	Min	Max	Default	ID	Description
P3.11.3.1	ON Time	hh:mm:ss	0:00:00	23:59:59	0:00:00	1474	See description for P3.11.1.1
P3.11.3.2	OFF Time	hh:mm:ss	0:00:00	23:59:59	0:00:00	1475	See description for P3.11.1.2
P3.11.3.3	From Day		Sunday	Saturday	Sunday	1476	See description for P3.11.1.3
P3.11.3.4	To Day		Sunday	Saturday	Sunday	1477	See description for P3.11.1.4
P3.11.3.5	AssignToChannel		Not Used	Time Channel 3	Not Used	1478	See description for P3.11.1.5

Interval 4 (M3.11.4)

Table 50: Interval 4.

Structure	Parameter	Unit	Min	Max	Default	ID	Description
P3.11.4.1	ON Time	hh:mm:ss	0:00:00	23:59:59	0:00:00	1479	See description for P3.11.1.1
P3.11.4.2	OFF Time	hh:mm:ss	0:00:00	23:59:59	0:00:00	1480	See description for P3.11.1.2
P3.11.4.3	From Day		Sunday	Saturday	Sunday	1481	See description for P3.11.1.3
P3.11.4.4	To Day		Sunday	Saturday	Sunday	1482	See description for P3.11.1.4
P3.11.4.5	AssignToChannel		Not Used	Time Channel 3	Not Used	1483	See description for P3.11.1.5

Interval 5 (M3.11.5)

Table 51: Interval 5.

Structure	Parameter	Unit	Min	Max	Default	ID	Description
P3.11.5.1	ON Time	hh:mm:ss	0:00:00	23:59:59	0:00:00	1484	See description for P3.11.1.1
P3.11.5.2	OFF Time	hh:mm:ss	0:00:00	23:59:59	0:00:00	1485	See description for P3.11.1.2
P3.11.5.3	From Day		Sunday	Saturday	Sunday	1486	See description for P3.11.1.3
P3.11.5.4	To Day		Sunday	Saturday	Sunday	1487	See description for P3.11.1.4
P3.11.5.5	AssignToChannel		Not Used	Time Channel 3	Not Used	1488	See description for P3.11.1.5

Timers

Timers can be used to set a time channel as active during a certain time by commanding from a digital input (or a time channel). For example, the settings below will set the timer as active when Digital Input 1 on slotA is closed and kept active for 30 seconds after it opened.

Duration: 30s

Timer: DigIN SlotA.1

Timer 1 (M3.11.6)

Table 52: Timer 1.

Structure	Parameter	Unit	Min	Max	Default	ID	Description
P3.11.6.1	Duration	s	0	72000	0	1489	Defines the amount of time to added to AssignToChannel (P3.11.6.2)
P3.11.6.2	AssignToChannel		Not Used	Time Channel 3	Not Used	1490	Defines the affected time channel (1-3) for the timer. 0 = Not used 1 = Time Channel 1 2 = Time Channel 2 3 = Time Channel 3

Timer 2 (M3.11.7)

Table 53: Timer 2.

Structure	Parameter	Unit	Min	Max	Default	ID	Description
P3.11.7.1	Duration	s	0	72000	0	1491	See description for P3.11.6.1
P3.11.7.2	AssignToChannel		Not Used	Time Channel 3	Not Used	1492	See description for P3.11.6.2

Timer 3 (M3.11.8)

Table 54: Timer 3.

Structure	Parameter	Unit	Min	Max	Default	ID	Description
P3.11.8.1	Duration	s	0	72000	0	1491	See description for P3.11.6.1
P3.11.8.2	AssignToChannel		Not Used	Time Channel 3	Not Used	1494	See description for P3.11.6.2

Example

Problem:

We have a variable frequency drive for air conditioning in a warehouse. It needs to run between 7:00 A.M. until 5:00 P.M. on weekdays, and 9:00 A.M. until 1:00 P.M. on weekends. Additionally, the drive must be manually forced to run outside working hours if there are people in the building, and must continue to run for 30 minutes afterwards.

Solution:

Set up two intervals: one for weekdays, and one for weekends. A timer is also needed for activation outside the normal office hours. The example configuration is completed as follows:

1. Interval 1 (used for the weekdays)
 - Set **ON Time** (P3.11.1.1) to a value of **07:00:00**.
 - Set **OFF Time** (P3.11.1.2) to a value of **17:00:00**.
 - Set **From Day** (P3.11.1.3) to a value of **Monday**.
 - Set **To Day** (P3.11.1.4) to a value of **Friday**.
 - Set **Assign to Channel** (P3.11.1.5) to a value of **Time Channel 1**.
2. Interval 2 (used for the weekends)
 - Set **ON Time** (P3.11.2.1) to a value of **09:00:00**.
 - Set **OFF Time** (P3.11.2.2) to a value of **13:00:00**.
 - Set **From Day** (P3.11.2.3) to a value of **Saturday**.
 - Set **To Day** (P3.11.2.4) to a value of **Sunday**.
 - Set **Assign to Channel** (P3.11.2.5) to a value of **Time Channel 1**.
3. Timer 1 (used for the override operation outside of normal office hours)
 - Set **Duration** (P3.11.6.1) to a value of **1800** (30 minutes).
 - Set **Assign to Channel** (P3.11.6.2) to a value of **Time Channel 1**.
 - Set **Timer 1** (P3.5.1.18) to a value of **DigIN Slot A.1**.
4. Control Source (location of the start/stop)

Set **Control Signal 1 A** (P3.5.1.1) to a value of **TimeChannel.1**.

PID Controller 1 (M3.12)

The PID Controller 1 settings are used to configure the first PID controller, which controls the speed of the motor that is physically connected to the drive's output.

PID Controller 1 consists of the following settings:

- Basic Settings
- Setpoints
- Feedback
- Feedforward
- Soft Fill
- Process Supervision
- Pressure Loss Compensation

Basic Settings (M3.12.1)

Table 55: Basic Settings.

Structure	Parameter	Unit	Min	Max	Default	ID	Description
P3.12.1.1	Gain	%	0	1000	100	118	Defines the proportional gain of the PID loop.
P3.12.1.2	Integration Time	s	0	600	1	119	Defines the integration time of the PID loop.
P3.12.1.3	Derivation Time	s	0	100	0	132	Defines the derivation time of the PID loop.

Structure	Parameter	Unit	Min	Max	Default	ID	Description
P3.12.1.4	ProcessUnitSel.		%	F	%	1036	See Table <i>Process Unit Selection</i> .
P3.12.1.5	ProcessUnitMin	Varies	Varies	Varies	0	1033	Defines the minimum of the range for the process unit.
P3.12.1.6	ProcessUnitMax	Varies	Varies	Varies	100	1034	Defines the maximum of the range for the process unit.
P3.12.1.7	ProcessUnitDeci.		0	4	2	1035	Defines the number of positions after the decimal place that will display.
P3.12.1.8	Error Inversion		Reverse Acting	Direct Acting	Reverse Acting	340	Defines the action of the PID loop. 0 = Reverse Acting (Fdbk < Stpt = > Increase PID Output) 1 = Direct Acting (Fdbk < Stpt = > Decrease PID Output)
P3.12.1.9	Dead Band	Varies	Varies	Varies	0	1056	Defines the dead band area around the setpoint in process units. The PID output is locked if the feedback stays within the dead band area for the Dead Band Delay (P3.12.1.10)
P3.12.1.10	Dead Band Delay	s	0	320	0	1057	Defines the time for dead band.

Table 56: Process Units Selection.

	Unit		Unit		Unit		Unit
0	%	10	kg/h	20	kW	30	ft3/h
1	l/min	11	m3/s	21	C	31	in wg
2	rpm	12	m3/min	22	gal/s	32	ft wg
3	ppm	13	m3/h	23	gal/min	33	PSI
4	pps	14	m/s	24	gal/h	34	lb/in2
5	l/2	15	mbar	25	lb/s	35	hp
6	l/min	16	bar	26	lb/min	36	F
7	l/h	17	Pa	27	lb/h		
8	kg/s	18	kPa	28	ft3/s		
9	kg/min	19	mVS	29	ft3/min		

Setpoints (M3.12.2)

Table 57: Setpoints.

Structure	Parameter	Unit	Min	Max	Default	ID	Description
P3.12.2.1	Keypad SP 1	Varies	Varies	Varies	0	167	Defines the primary keypad setpoint if selected by SP1 Source (P3.12.2.4).
P3.12.2.2	Keypad SP 2	Varies	Varies	Varies	0	168	Defines the secondary keypad setpoint if selected by SP1 Source (P3.12.2.4).
P3.12.2.3	Ramp Time	s	0	300	0	1068	Defines the rising and falling ramp times for setpoint changes.

Structure	Parameter	Unit	Min	Max	Default	ID	Description
P3.12.2.4	SP 1 Source		Not Used	Test Sequence	Keypad SP1	332	See Table <i>Setpoint Source</i> . AIs and ProcessDataIn's are handled as percent and scaled according to Setpoint Min and Setpoint Max. NOTE: ProcessDataIn uses two decimals.
P3.12.2.5	SP 1 Minimum	%	-200	200	0	1069	Minimum value of Setpoint at Analog Signal Minimum.
P3.12.2.6	SP 1 Maximum	%	-200	200	100	1070	Maximum value of Setpoint at Analog Signal Maximum.
P3.12.2.7	SP 1 Sleep Freq	Hz	0	320	0	1016	Define the frequency at which Sleep Mode activates.
P3.12.2.8	SP 1 Sleep Delay	s	0	3000	0	1017	Minimum amount of time the frequency has to remain below Sleep Level before the drive is stopped.
P3.12.2.9	SP 1 WakeUpLevel	Varies			0	1018	Defines the level for the PID feedback value wake-up supervision.
P3.12.2.10	SP 1 Boost	x	-2	2	1	1071	Setpoint can be boosted with a digital input.
P3.12.2.11	SP 2 Source		Not Used	Test Sequence	Keypad SP2	431	See description for SP 1 Source (P3.12.2.4)
P3.12.2.12	SP 2 Minimum	%	-200	200	0	1073	Minimum value of Setpoint at Analog Signal Minimum.
P3.12.2.13	SP 2 Maximum	%	-200	200	100	1074	Maximum value of Setpoint at Analog Signal Maximum.
P3.12.2.14	SP 2 Sleep Freq	Hz	0	320	0	1075	Define the frequency at which Sleep Mode activates.
P3.12.2.15	SP 2 Sleep Delay	s	0	3000	0	1076	Minimum amount of time the frequency has to remain below Sleep Level before the drive is stopped.
P3.12.2.16	SP 2 WakeUpLevel	Varies			0	1077	Defines the level for the PID feedback value wake-up supervision.
P3.12.2.17	SP 2 Boost	x	-2	2	1	1078	Setpoint can be boosted with a digital input.

Table 58: Setpoint Source.

Settings	Description
0	Not Used Setpoint is not used.
1	Keypad Setpoint 1 Use keypad setpoint 1.
2	Keypad Setpoint 2 Use keypad setpoint 2.
3	AI1 Use analog input 1.
4	AI2 Use analog input 2.

Settings		Description
5	AI3	Use analog input 3.
6	AI4	Use analog input 4.
7	AI5	Use analog input 5.
8	AI6	Use analog input 6.
9	ProcessDataIn1	Use ProcessDataIn1.
10	ProcessDataIn2	Use ProcessDataIn2.
11	ProcessDataIn3	Use ProcessDataIn3.
12	ProcessDataIn4	Use ProcessDataIn4.
13	ProcessDataIn5	Use ProcessDataIn5.
14	ProcessDataIn6	Use ProcessDataIn6.
15	ProcessDataIn7	Use ProcessDataIn7.
16	ProcessDataIn8	Use ProcessDataIn8.
17	Test Sequence	

Feedbacks (M3.12.3)

Table 59: Feedback.

Structure	Parameter	Unit	Min	Max	Default	ID	Description
P3.12.3.1	Function		Source1	Mean	Source1	333	Settings: 1 = Only Source 1 in use 2 = $\text{SQRT}(\text{Source1})$; (Flow = $\text{Constant} \times \text{SQRT}[\text{Pressure}]$) 3 = $\text{SQRT}(\text{Source1} - \text{Source2})$ 4 = $\text{SQRT}(\text{Source1}) + \text{SQRT}(\text{Source2})$ 5 = $\text{Source1} + \text{Source2}$ 6 = $\text{Source1} - \text{Source2}$ 7 = $\text{Min}(\text{Source1}, \text{Source2})$ 8 = $\text{Max}(\text{Source1}, \text{Source2})$ 9 = $\text{Mean}(\text{Source1}, \text{Source2})$
P3.12.3.2	Gain	%	-1000	1000	100	1058	Used with selection 2 in Feedback Function (P3.12.3.1)
P3.12.3.3	FB 1 Source		Not Used	ProcessDataIn8	AI2	334	See Table <i>Feedback Sources</i> . AIs and ProcessDataIn are handled as % and scaled according to feedback min & max. NOTE: ProcessDataIn settings use two decimal places.
P3.12.3.4	FB 1 Minimum	%	-200	200	0	336	Minimum value at Analog Signal Minimum.

Structure	Parameter	Unit	Min	Max	Default	ID	Description
P3.12.3.5	FB 1 Maximum	%	-200	200	100	337	Maximum value at Analog Signal Maximum.
P3.12.3.6	FB 2 Source		Not Used	ProcessDataIn8	Not Used	335	See FB 1 Source (P3.12.3.3).
P3.12.3.7	FB 2 Minimum	%	-200	200	0	338	Minimum value at Analog Signal Minimum.
P3.12.3.8	FB 2 Maximum	%	-200	200	100	339	Maximum value at Analog Signal Maximum.

Table 60: Feedback Sources.

Settings		Description
0	Not Used	Setpoint is not used.
1	AI1	Use analog input 1.
2	AI2	Use analog input 2.
3	AI3	Use analog input 3.
4	AI4	Use analog input 4.
5	AI5	Use analog input 5.
6	AI6	Use analog input 6.
7	ProcessDataIn1	Use ProcessDataIn1.
8	ProcessDataIn2	Use ProcessDataIn2.
9	ProcessDataIn3	Use ProcessDataIn3.
10	ProcessDataIn4	Use ProcessDataIn4.
11	ProcessDataIn5	Use ProcessDataIn5.
12	ProcessDataIn6	Use ProcessDataIn6.
13	ProcessDataIn7	Use ProcessDataIn7.
14	ProcessDataIn8	Use ProcessDataIn8.

Feedforward (M3.12.4)

Table 61: Feedforward.

Structure	Parameter	Unit	Min	Max	Default	ID	Description
P3.12.4.1	Function		Source1	Mean	Source1	1059	Settings: 1 = Only Source 1 in use 2 = SQRT(Source1); (Flow = ConstantxSQRT(Pressure)) 3 = SQRT(Source1-Source2) 4 = SQRT(Source1) + SQRT(Source2) 5 = Source1 + Source2 6 = Source1 - Source2 7 = Min(Source1, Source2) 8 = Max(Source1, Source2) 9 = Mean(Source1, Source2)
P3.12.4.2	Gain	%	-100	100	100	1060	Used with selection 2 in Feedforward Function (P3.12.4.1)
P3.12.4.3	FF 1 Source		Not Used	ProcessDataIn8	Not Used	1061	Settings: 0 = Not used 1 = AI1 2 = AI2 3 = AI3 4 = AI4 5 = AI5 6 = AI6 7 = ProcessDataIn1 8 = ProcessDataIn2 9 = ProcessDataIn3 10 = ProcessDataIn4 11 = ProcessDataIn5 12 = ProcessDataIn6 13 = ProcessDataIn7 14 = ProcessDataIn8 AIs and ProcessDataIn are handled as % and scaled according to feedback min and max. NOTE: ProcessDataIn settings use two decimal places.
P3.12.4.4	FF 1 Minimum	%	-200	200	0	1062	Minimum value at Analog Signal Minimum.
P3.12.4.5	FF 1 Maximum	%	-200	200	100	1063	Maximum value at Analog Signal Maximum.
P3.12.4.6	FF 2 Source		Not Used	ProcessDataIn8	Not Used	1064	See FF 1 Source (P3.12.4.3).
P3.12.4.7	FF 2 Minimum	%	-200	200	0	1065	Minimum value at Analog Signal Minimum.
P3.12.4.8	FF 2 Maximum	%	-200	200	100	1066	Maximum value at Analog Signal Maximum.

Process Supervision (M3.12.5)

Table 62: Process Supervision.

Structure	Parameter	Unit	Min	Max	Default	ID	Description
P3.12.5.1	Enable Superv		Disabled	Enabled	Disabled	735	Settings: 0 = Disabled 1 = Enabled
P3.12.5.2	Upper Limit	Varies	Varies	Varies	Varies	736	Upper actual/process value supervision.
P3.12.5.3	Lower Limit	Varies	Varies	Varies	Varies	758	Lower actual/process value supervision.
P3.12.5.4	Delay	s	0	30000	0	737	If the desired value is not reached within this time, a fault or alarm is created.

Pressure Loss Compensation (M3.12.6)

Table 63: Pressure Loss Compensation.

Structure	Parameter	Unit	Min	Max	Default	ID	Description
P3.12.6.1	Enable SP 1		Disabled	Enabled	Disabled	1189	Enables the drive to raise or lower the setpoint depending on output frequency. SP 1 Max Comp. (P3.12.6.2) is the compensation at maximum frequency. This can be used with incorrectly placed sensors. For example, if a pressure sensor is placed far away from the wanted pressure and the error in the measurement is in proportion to the flow/output frequency. 0 = Disabled 1 = Enabled
P3.12.6.2	SP 1 Max Comp.	%	-214748.36	214748.36	0	1190	Value added proportionally to the frequency. Setpoint Compensation = SP 1 Max Comp. (P3.12.6.2) * (Output Frequency [M2.2.1]) - Min Frequency [P3.3.1]) / (Max Frequency [P3.3.2] - Min Frequency [P3.3.1])
P3.12.6.3	Enable SP 2	Varies	Disabled	Enabled	Disabled	1191	Enables the drive to raise or lower the setpoint depending on output frequency. SP 2 Max Comp. (P3.12.6.2) is the compensation at maximum frequency. This can be used with incorrectly placed sensors. For example, if a pressure sensor is placed far away from the wanted pressure and the error in the measurement is in proportion to the flow/output frequency. 0 = Disabled 1 = Enabled
P3.12.6.4	SP 2 Max Comp.	%	-214748.36	214748.36	0	1192	Value added proportionally to the frequency. Setpoint Compensation = SP 2 Max Comp. (P3.12.6.4) * (Output Frequency [M2.2.1] - Min Frequency [P3.3.1]) / (Max Frequency [P3.3.2] - Min Frequency [P3.3.1].)

PID Control Sequence Details

Dead band hysteresis (P3.12.1.9) and Dead band delay (P3.12.1.10)

The PID controller output is locked if the actual value stays within the dead band area around the reference for a predefined time. This function prevents unnecessary movement and wear on actuators and valves.

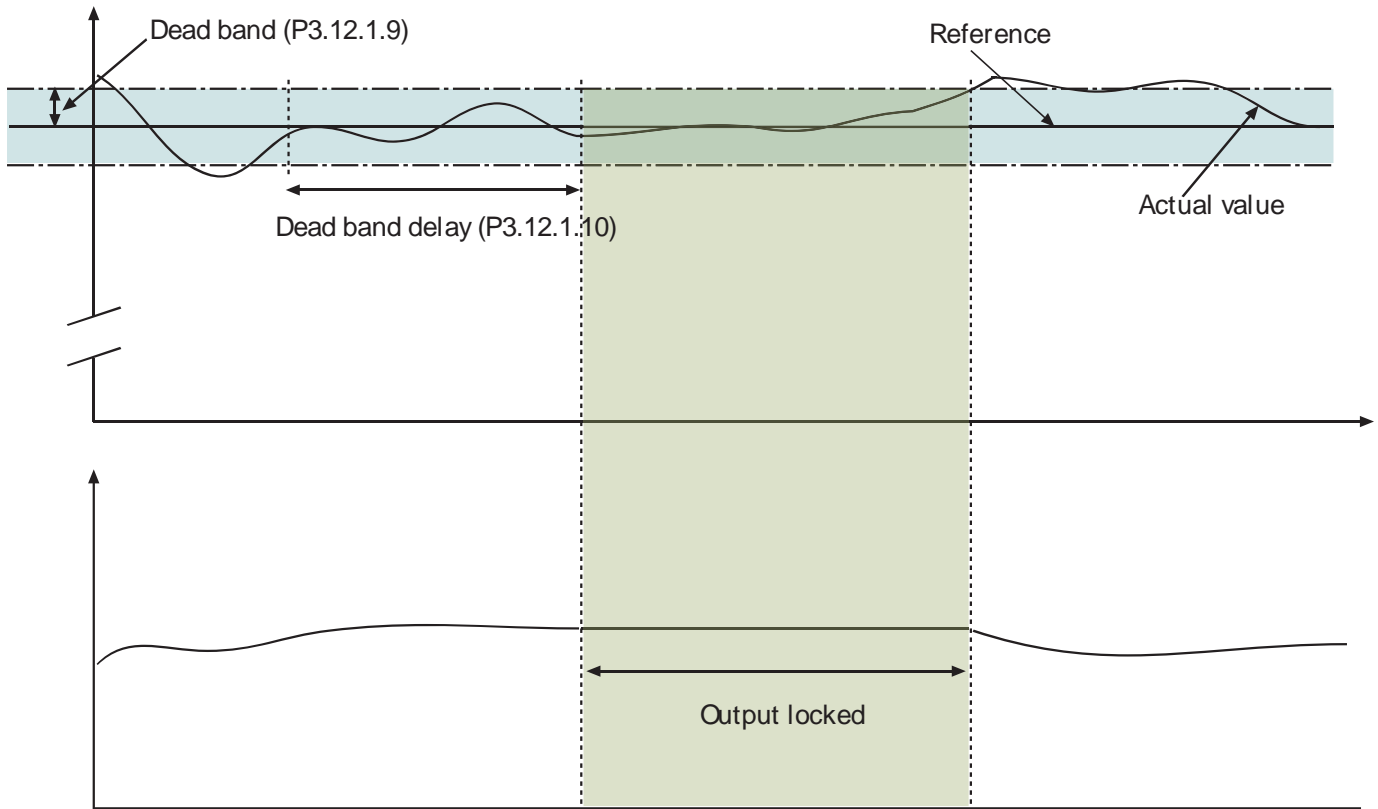

11105.emf

Figure 25: Dead band.

Sleep frequency limit 1 (P3.12.2.7), Sleep delay 1 (P3.12.2.8), and Wake-up level 1 (P3.12.2.9)

This function puts the drive into sleep mode if the frequency stays below the sleep limit for a longer period than that set with the **Sleep Delay** (P3.12.2.8). This means that the start command remains on, but the run request is turned off. When the actual value goes below or above the wake-up level depending on the set acting mode, the drive will activate the run request again, if the start command is still on.

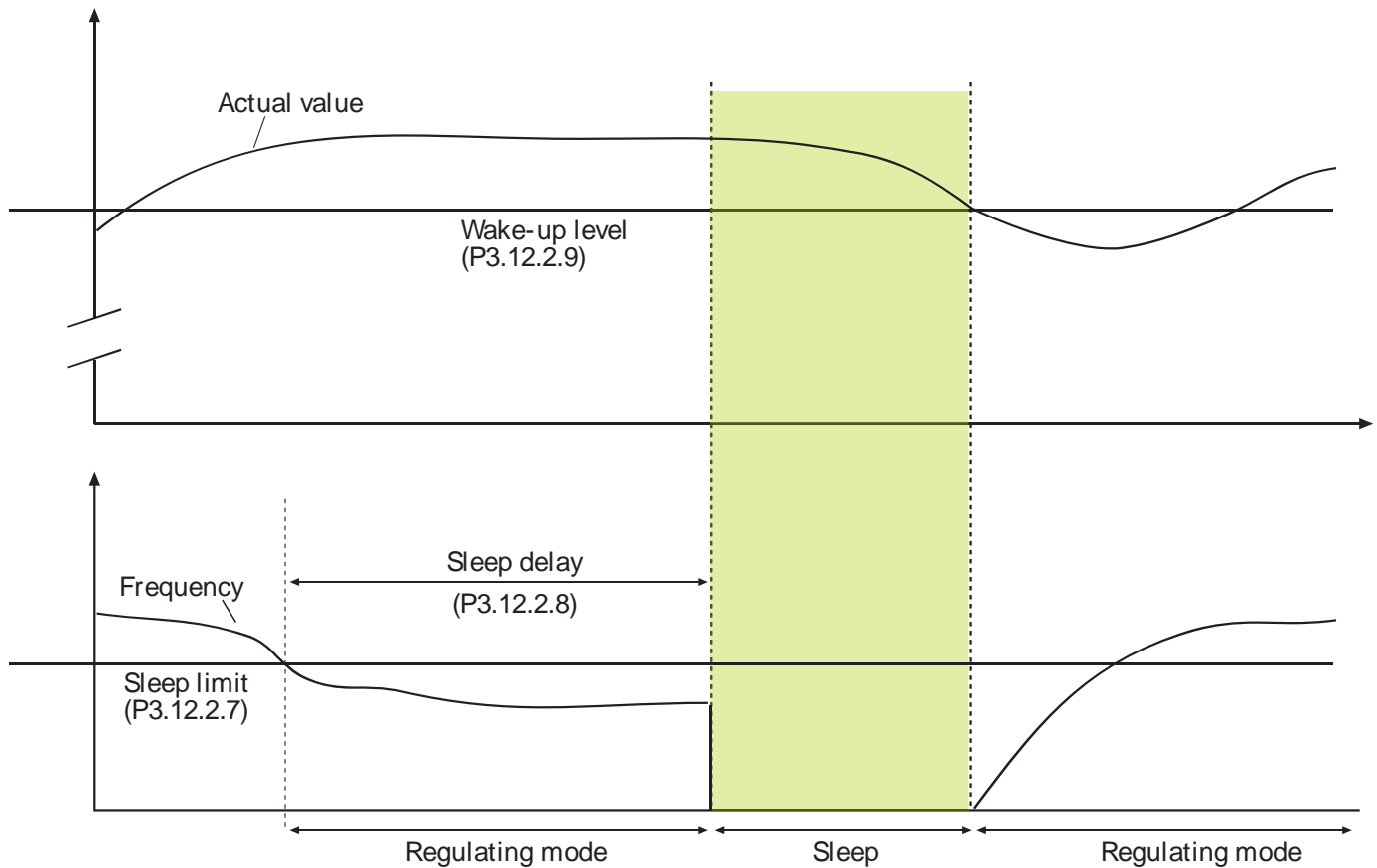

11106.emf

Figure 26: Sleep limit, Sleep delay, Wake-up level.

Feedforward function (P3.12.4.1)

Feedforward usually needs accurate process models, but in some cases, a gain + offset type of feedforward is enough. The feedforward part does not use any feedback measurements of the actual controlled process value (water level in the following Example). Siemens feedforward control uses other measurements which are indirectly affecting the controlled process value.

Example:

You are controlling the water level of a tank by means of flow control. The desired water level has been defined as a setpoint and the actual level as feedback. The control signal acts on the incoming flow.

Think of the outflow as a disturbance that can be measured. Based on the measurements of the disturbance, you can try to compensate for this disturbance with a simple feedforward control (gain and offset) which is added to the PID output.

This way, the controller will react much faster to changes in the outflow than if you had just measured the level.

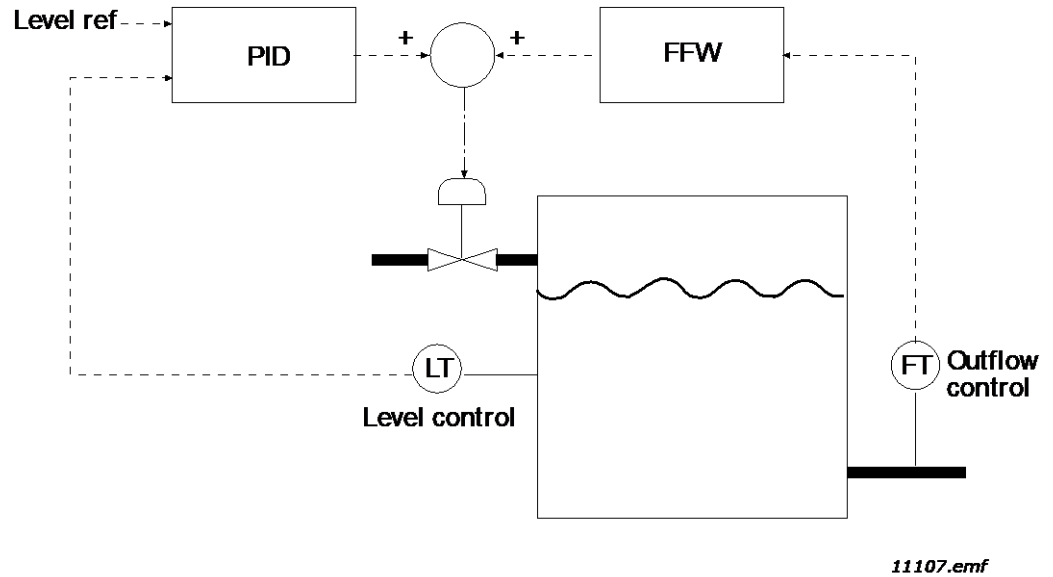

Figure 27: Feedforward Control.

Enable process supervision (P3.12.5.1)

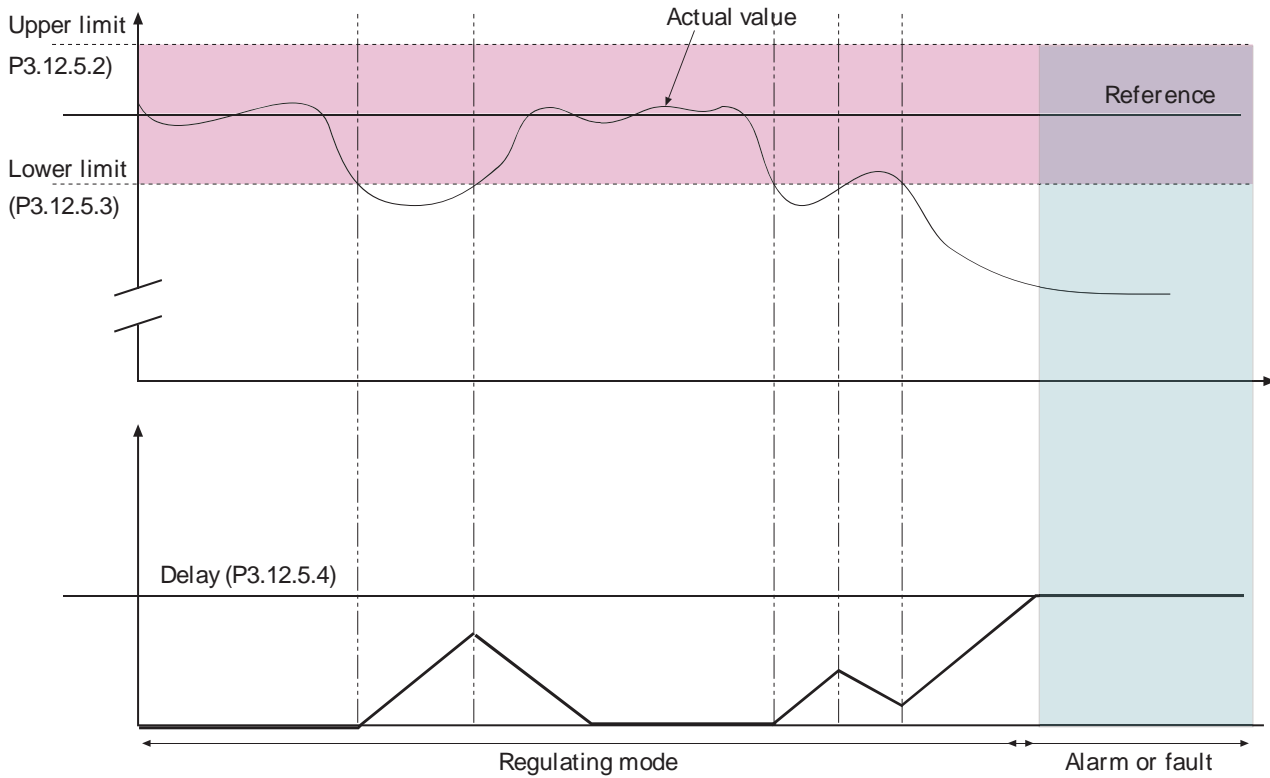
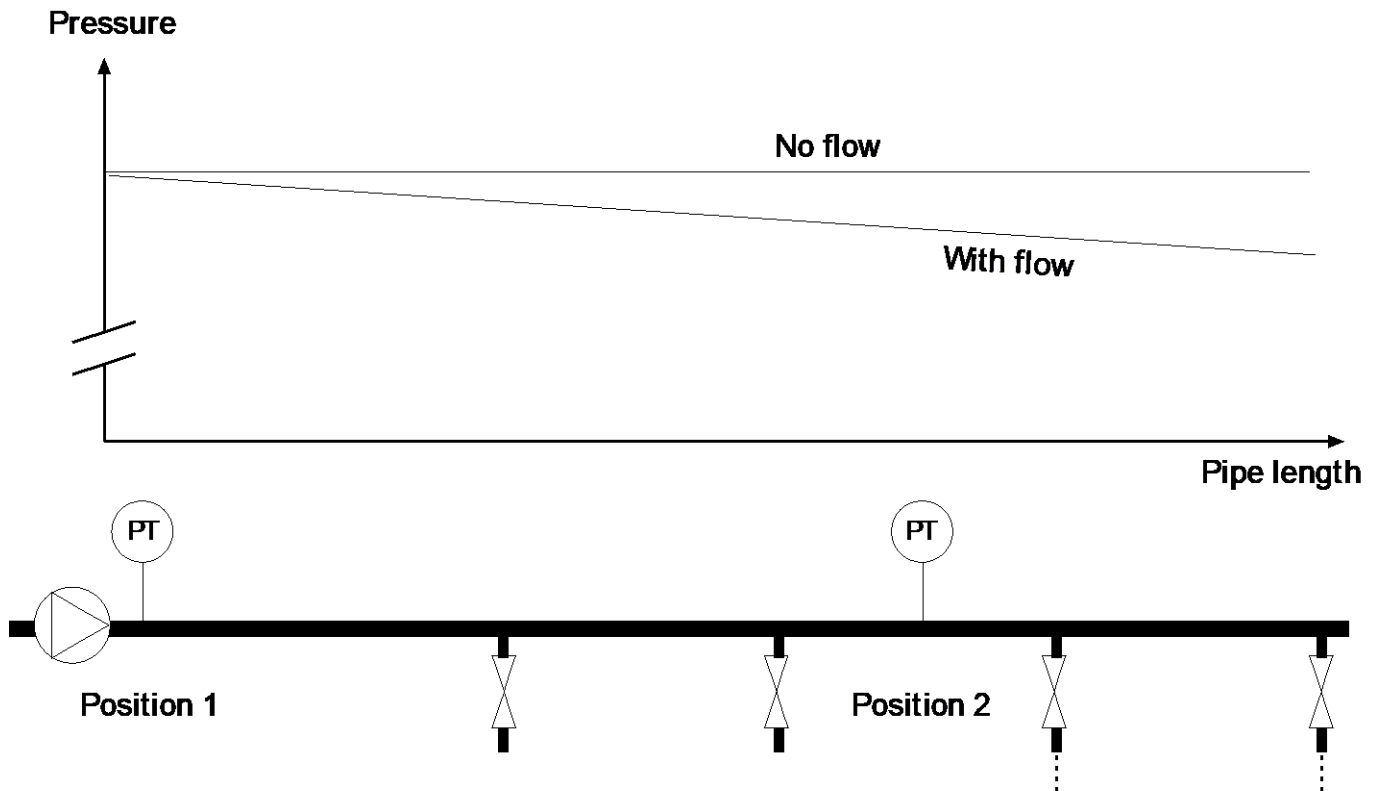

Figure 28: Process Supervision.

Upper and lower limits around the reference are set. When the actual value goes above or below, a counter starts counting up towards the **Delay** (P3.12.5.4). When the actual value is within the allowed area, the same counter counts down instead. Whenever the counter is higher than the Delay, an alarm or fault (depending on the selected response) is generated.



Pressure Loss Compensation



11109.emf

Figure 29: Position of Pressure Sensor.

If pressurizing a long pipe with many outlets, the best place for the sensor is probably halfway down the pipe (Position 2). However, sensors may, for example, be placed directly after the pump. This will give the right pressure directly after the pump, but farther down in the pipe the pressure will drop depending on the flow.

Enable Setpoint 1 (P3.12.6.1), and Setpoint 1 max compensation (P3.12.6.2)

The sensor is placed in Position 1. The pressure in the pipe will remain constant when we have no flow. However, with flow, the pressure will drop farther down in the pipe. This can be compensated by raising the setpoint as the flow increases. In this case, the flow is estimated by the output frequency and the setpoint is linearly increased with the flow as in the figure below.

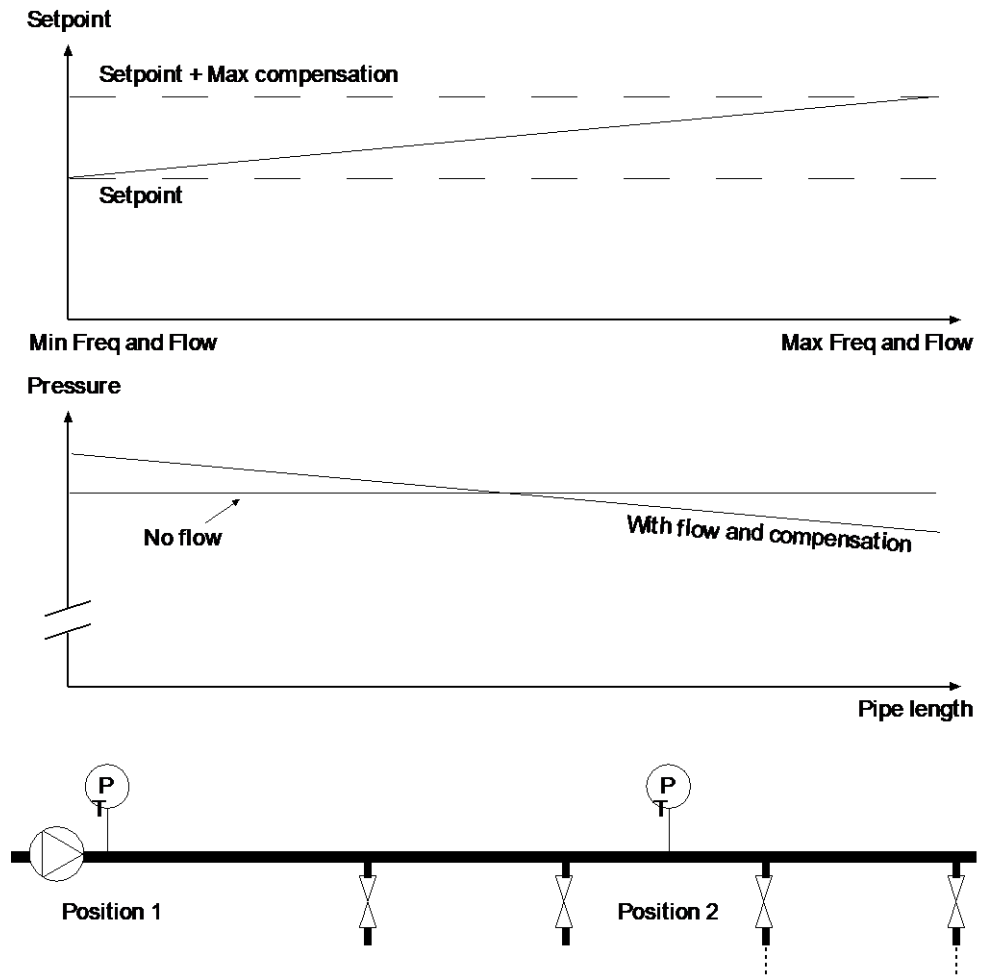

11110.emf

Figure 30: Enable Setpoint 1 for Pressure Loss Compensation.

PID Controller 2 (M3.13)

The PID Controller 2 settings configure the second PID controller, which controls an external device.

The PID Controller 2 consists of the following settings:

- Basic Settings
- Setpoints
- Feedback
- Process Supervision

Basic Settings (M3.13.1)

Table 64: PID Controller 2 Basic Settings.

Structure	Parameter	Unit	Min	Max	Default	ID	Description
P3.13.1.1	Enable PID		Disabled	Enabled	Disabled	1630	Enable parameter for the second PID controller.
P3.13.1.2	Output in Stop	%	0	100	0	1100	The output value of the PID control in % of its maximum output value while it is stopped using Digital Input.
P3.13.1.3	Gain	%	0	1000	100	1631	Defines the proportional gain of the PID loop.
P3.13.1.4	Integration Time	s	0	600	1	1632	Defines the integration time of the PID loop.
P3.13.1.5	Derivation Time	s	0	100	0	1633	Defines the derivation time of the PID loop.
P3.13.1.6	ProcessUnitSel.		%	F	%	1635	See Table <i>Process Unit Selection</i> .
P3.13.1.7	ProcessUnitMin	Varies	Varies	Varies	0	1664	Defines the minimum of the range for the process unit.
P3.13.1.8	ProcessUnitMax	Varies	Varies	Varies	100	1665	Defines the maximum of the range for the process unit.
P3.13.1.9	ProcessUnitDeci.		0	4	2	1666	Defines the number of positions after the decimal place that is to be displayed.
P3.13.1.10	Error Inversion		Normal	Inverted	Normal	1636	Defines the action of the PID loop. 0 = Reverse Acting (Fdbk < Stpt = > Increase PID Output) 1 = Direct Acting (Fdbk < Stpt = > Decrease PID Output)
P3.13.1.11	Dead Band	Varies	Varies	Varies	0	1637	Defines the dead band area around the setpoint in process units. The PID output is locked if the feedback stays within the dead band area for the Dead Band Delay (P3.13.1.12).
P3.13.1.12	Dead Band Delay	s	0	320	0	1638	Defines the time for dead band.

Setpoints (M3.13.2)

Table 65: PID Controller 2 Setpoints.

Structure	Parameter	Unit	Min	Max	Default	ID	Description
P3.13.2.1	Keypad SP 1	Varies	Varies	Varies	0	1640	Defines the primary keypad setpoint if selected by SP1 Source (P3.13.2.4).
P3.13.2.2	Keypad SP 2	Varies	Varies	Varies	0	1641	Defines the secondary keypad setpoint if selected by SP1 Source (P3.13.2.4).
P3.13.2.3	Ramp Time	s	0	300	0	1642	Defines the rising and falling ramp times for setpoint changes.

Structure	Parameter	Unit	Min	Max	Default	ID	Description
P3.13.2.4	SP 1 Source		Not Used	Test Sequence	Keypad SP1	1643	See Table <i>Setpoint Sources</i> . AIs and ProcessDataIn settings are handled as percent and scaled according to Setpoint Min and Setpoint Max. NOTE: Settings 9 through 16 use two decimal places.
P3.13.2.5	SP 1 Minimum	%	-200	200	0	1644	Minimum value of Setpoint at Analog Signal Minimum.
P3.13.2.6	SP 1 Maximum	%	-200	200	100	1645	Maximum value of Setpoint at Analog Signal Maximum.
P3.13.2.7	SP 2 Source		Not Used	Test Sequence	Not Used	1646	See SP1 Source (P3.13.2.4).
P3.13.2.8	SP 2 Minimum	%	-200	200	0	1647	Minimum value of Setpoint at Analog Signal Minimum.
P3.13.2.9	SP 2 Maximum	%	-200	200	100	1648	Maximum value of Setpoint at Analog Signal Maximum.

Feedback (M3.13.3)

Table 66: PID Controller 2 Feedback.

Structure	Parameter	Unit	Min	Max	Default	ID	Description
P3.13.3.1	Function		Source1	Mean	Source1	1650	Settings: 1 = Only Source 1 in use 2 = SQRT(Source1); (Flow = ConstantxSQRT(Pressure)) 3 = SQRT(Source1-Source2) 4 = SQRT(Source1) + SQRT(Source2) 5 = Source1 + Source2 6 = Source1 - Source2 7 = Min(Source1, Source2) 8 = Max(Source1, Source2) 9 = Mean(Source1, Source2)
P3.13.3.2	Gain	%	-1000	1000	100	1651	Used with selection 2 in Feedback Function (P3.12.3.1)
P3.13.3.3	FB 1 Source		Not Used	ProcessDataIn8	AI1	1652	See Table <i>Feedback Sources</i> . AIs and ProcessDataIn settings are handled as % and scaled according to feedback min and max. NOTE: Settings 7 through 14 use two decimal places.
P3.13.3.4	FB 1 Minimum	%	-200	200	0	1653	Minimum value at Analog Signal Minimum.
P3.13.3.5	FB 1 Maximum	%	-200	200	100	1654	Maximum value at Analog Signal Maximum.
P3.13.3.6	FB 2 Source		Not Used	ProcessDataIn8	AI2	1655	See FB 1 Source (P3.12.3.3).
P3.13.3.7	FB 2 Minimum	%	-200	200	0	1656	Minimum value at Analog Signal Minimum.
P3.13.3.8	FB 2 Maximum	%	-200	200	100	1657	Maximum value at Analog Signal Maximum.

Process Supervision (M3.13.4)

Table 67: PID Controller 2 Process Supervision.

Structure	Parameter	Unit	Min	Max	Default	ID	Description
P3.13.4.1	Enable Superv		Disabled	Enabled	Disabled	1659	Settings: 0 = Disabled 1 = Enabled
P3.13.4.2	Upper Limit	Varies	Varies	Varies	Varies	1660	Upper actual/process value supervision.
P3.13.4.3	Lower Limit	Varies	Varies	Varies	Varies	1661	Lower actual/process value supervision.
P3.13.4.4	Delay	s	0	30000	0	1662	If the desired value is not reached within this time, a fault or alarm is created.

Multi-pump (M3.14)

The Multi-Pump functionality controls up to four motors (pumps or fans) with PID Controller 1. The drive is connected to one motor which is the regulating motor. This motor connects and disconnects the other motors to/from the mains using contactors controlled with relays when needed, to maintain the correct setpoint.

The Auto-Change function controls the order/priority in which the motors are started to guarantee their equal wear. The controlling motor can be included in the Auto-Change and interlock logic, or it may be selected to always function as Motor 1. Motors can be taken out of use momentarily (for example, for service). This is completed using the interlock function.

The Multi-Pump settings are presented in the following table:

Table 68: Multi-pump Settings.

Structure	Parameter	Unit	Min	Max	Default	ID	Description
P3.14.1	Number of Motors		1	4	1	1001	Defines the total number of motors to be used with the multi-pump function.
P3.14.2	Interlock Funct.		Disabled	Enabled	Disabled	1032	Enables parameter for the interlock function to be used with the multi-pump function. Interlocks are used to tell the system if a motor is connected or not. 0 = Disabled 1 = Enabled
P3.14.3	Include FC		Disabled	Enabled	Enabled	1028	Defines if the motor connected to the drive is included in the auto-change function or not. 0 = Disabled (Not included) 1 = Enabled (included)
P3.14.4	Autochange		Disabled	Enabled	Disabled	1027	Disable/enable rotation of starting order and priority of motors. 0 = Disabled 1 = Enabled
P3.14.5	Autoch Interval	h	0	3000	48	1029	Defines the time between auto change in accordance with Autoch:FreqLim (P3.14.6) and AutochMotorLimit (P3.14.7).

Structure	Parameter	Unit	Min	Max	Default	ID	Description
P3.14.6	Autoch:FreqLim	Hz	0	50	25	1031	Defines the level which the auto change is capable to take place.
P3.14.7	AutochMotorLimit		0	4	1	1030	Defines the level which the auto change is capable to take place.
P3.14.8	Bandwidth	%	0	100	10	1097	Percentage of the setpoint.
P3.14.9	Bandwidth Delay	s	0	3600	10	1098	Feedback outside the bandwidth, time must pass before pumps are added or removed.

Multi-Pump

Motors are connected/disconnected if the PID controller is not able to keep the process value or feedback within the defined bandwidth around the setpoint.

Criteria for connecting/adding motors (also see the following figure):

- Feedback value outside the bandwidth area.
- Regulating motor running at a “close-to-max” frequency (-2 Hz).
- Conditions above are fulfilled for a time longer than the bandwidth delay.
- There are additional motors available.

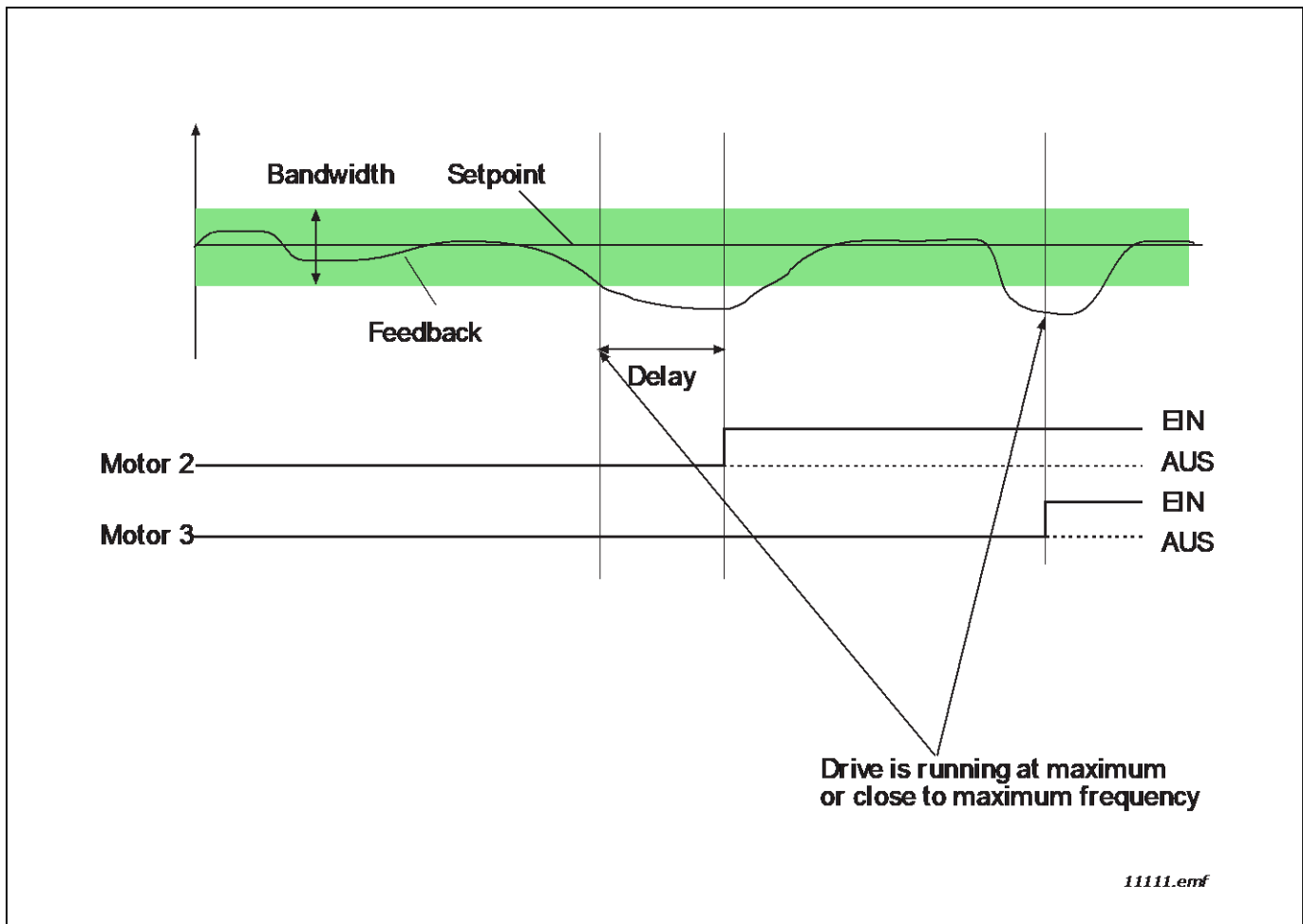

Figure 31:

Criteria for disconnecting/removing motors:

- Feedback value outside bandwidth area.
- Regulating motor running at a “close-to-min” frequency (+2 Hz).
- Conditions above are fulfilled for a time longer than the bandwidth delay
- There are more motors running than the regulating one.

Interlock function (P3.14.2)

Interlocks can be used to tell the Multi Pump system that a motor is not available, for example, because the motor is removed from the system for maintenance or bypassed for manual control.

Enable this function to use the interlocks. Choose the needed status for each motor by digital inputs (**Interlock1** (P3.5.1.26) to **Interlock 5** (P3.5.1.30)). If the input is closed (TRUE) the motor is available for the Multi-Pump system; otherwise, it will not be connected by the Multi-Pump logic.

Example of the Interlock logic:

If the motor starting order is

$1 \rightarrow 2 \rightarrow 3 \rightarrow 4 \rightarrow 5$

When the interlock of motor **3** is removed (the value of **Interlock 3** (P3.5.1.28) is set to **FALSE**) the order changes to:

$1 \rightarrow 2 \rightarrow 4 \rightarrow 5$

If motor **3** is taken into use again (changing the value of **Interlock 3** (P3.5.1.28) to TRUE), the system runs without stopping and motor **3** is placed last in the sequence:

$1 \rightarrow 2 \rightarrow 4 \rightarrow 5 \rightarrow 3$

The next time the system is stopped or goes to sleep mode, the sequence returns to its original order.

$1 \rightarrow 2 \rightarrow 3 \rightarrow 4 \rightarrow 5$

Include FC (P3.14.3)

Table 69: Include FC Selections.

Selection	Selection name	Description
0	Disabled	Motor 1 (motor connected to variable frequency drive) is always frequency controlled and not affected by interlocks.
1	Enabled	All motors can be controlled and are affected by interlocks.

Wiring

There are two different ways to make the connections depending on whether selection **0** or **1** is set as parameter value.

Selection 0, **Disabled**:

The variable frequency drive or the regulating motor is not included in the auto-change or interlocks logic. The drive is directly connected to motor 1 as in the following figure. The other motors are auxiliary ones connected to the mains by contactors and controlled by relays in the drive.

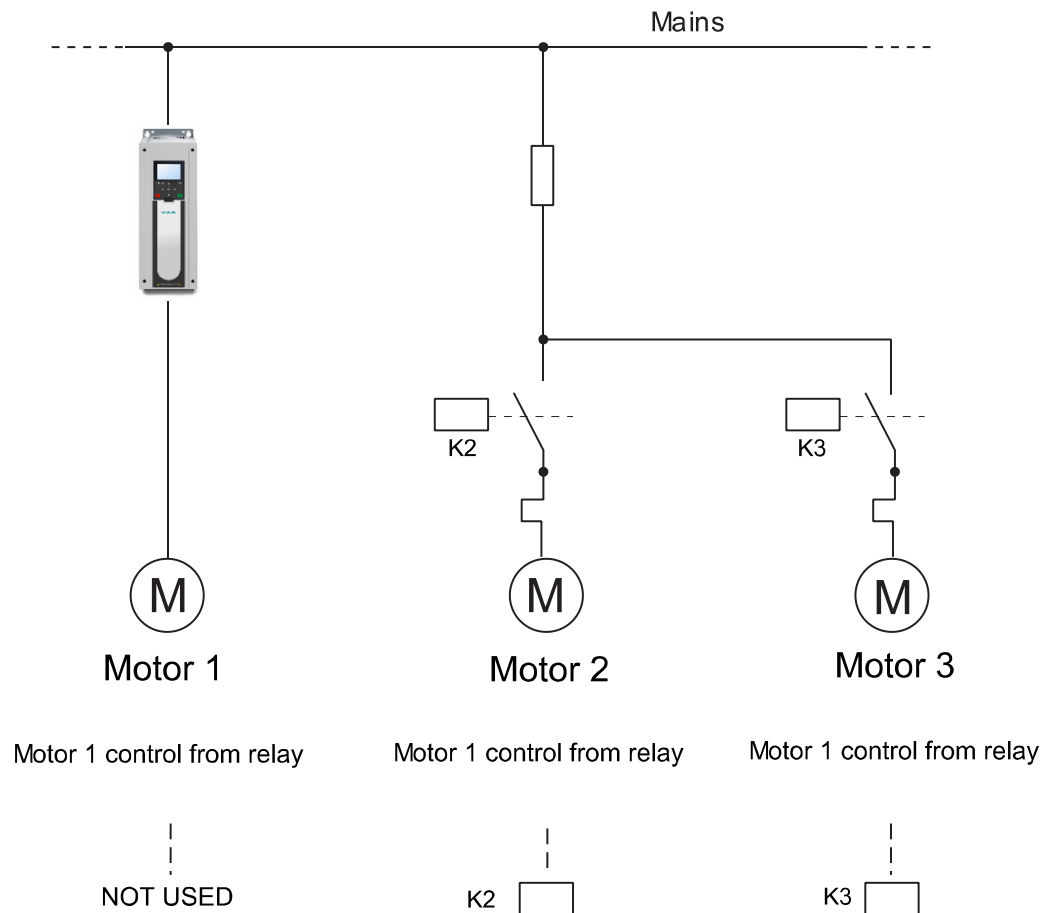

BT11112

Figure 32: Multi-pump: FC Disabled.

Selection 1, Enabled:

If the regulating motor needs to be included in the auto-change or interlock logic make the connection according to the following figure.

Each motor is controlled by a relay, but the contact logic ensures that the first connected motor is always connected to the drive and near the mains.

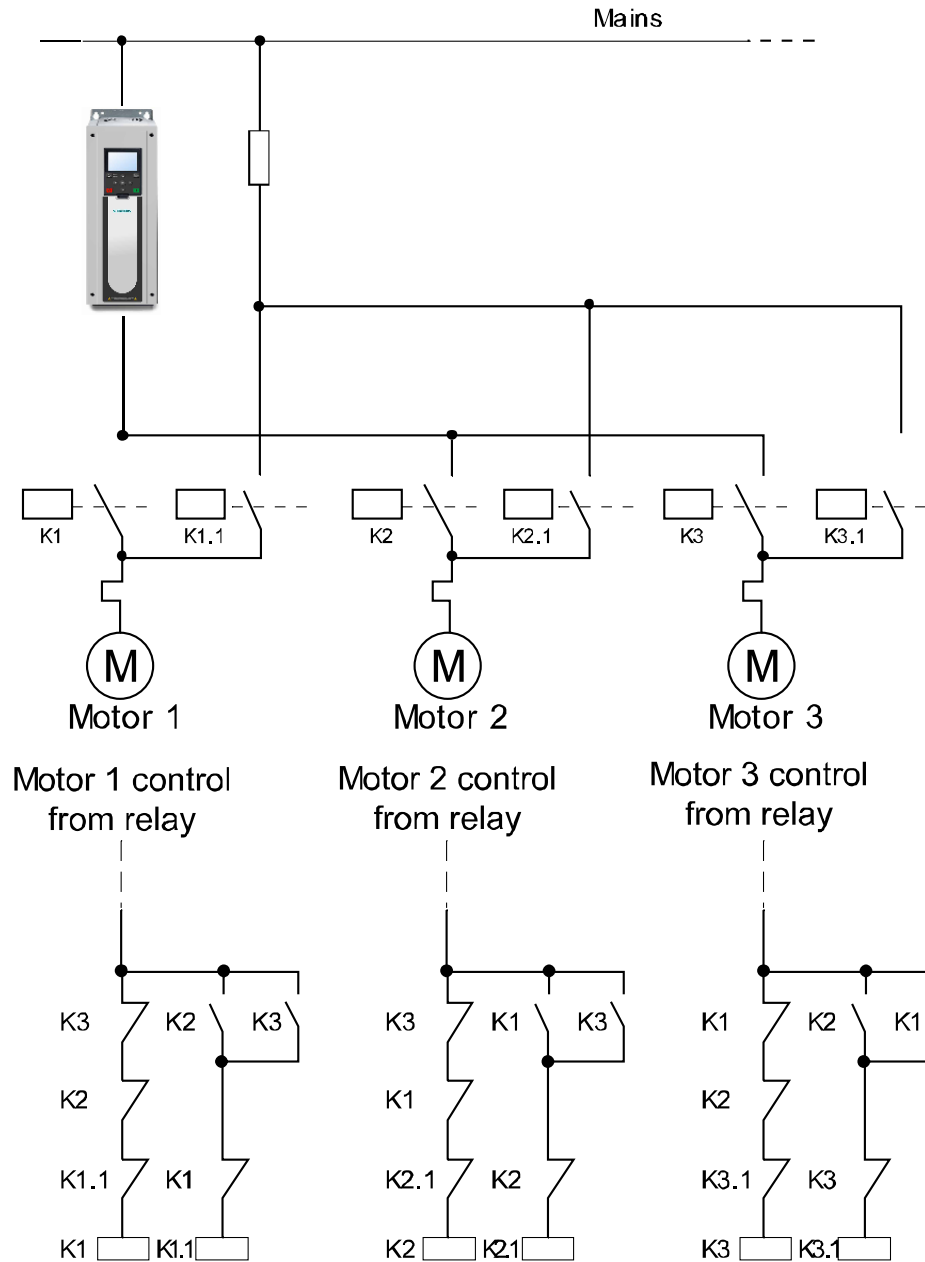

BT1113

Figure 33: Multi-pump: FC Enabled.

Auto-change (P3.14.4)

Table 70: Auto-Change Selections.

Selection	Selection Name	Description
0	Disabled	The priority/starting order of the motors is always 1-2-3-4-5 in normal operation. It may have changed during its run if interlocks have been removed and added again, but the priority/order is always restored after a stop.
1	Enabled	The priority is changed at certain intervals to get an equal wear on all motors. The intervals of the auto-change can be changedAutochInterval (P3.14.5). You can also set a limit for how many motors are allowed to run AutochMotorLimit (P3.14.7) as well as for the maximum frequency of the regulating drive when the auto-change is done Autoch:FreqLim (P3.14.6). If the auto-change interval Autoch Interval (P3.14.5) has expired, but the frequency and motor limits are not fulfilled, the auto-change will be postponed until all conditions are met (this is to avoid for example sudden pressure drops while the system is performing an auto-change when there is a high capacity demand at a pump station).

Example:

In the auto-change sequence after the auto-change has taken place, the motor with the highest priority is placed last and the others are moved up by one place:

Starting order/priority of motors: 1 → 2 → 3 → 4 → 5

→ *Autochange* →

Starting order/priority of motors: 2 → 3 → 4 → 5 → 1

→ *Autochange* →

Starting order/priority of motors: 3 → 4 → 5 → 1 → 2

Fire Mode (M3.16)

The drive ignores all commands from the keypad, fieldbuses, and the PC tool and runs at the speed defined in **Fire Mode Frequency Source** (P3.16.5) when the mode is activated. If activated, the alarm sign displays on the keypad and the warranty is void. To enable the function, a password must be set in **Fire Mode Password** (P3.16.1).



NOTE:

The warranty is void if the Fire Mode function is activated. Test Mode can be used to test the Fire Mode function without voiding the warranty.

There is a different password for test mode, to be used for testing the Fire Mode without the warranty becoming void.

The Fire Mode settings are presented in the following table:

Table 71: Fire Mode Settings.

Structure	Parameter	Unit	Min	Max	Default	ID	Description
P3.16.1	FireMode Passwd		0	9999	0	1599	Defines use of the Fire Mode. Fire Mode is enabled when set to a value of 1001 . A test mode can be entered by setting to a value of 1234 previous to the next activation as defined by FireMode Activ.Open (P3.16.2) or FireMode Activ.Close (P3.16.3).
P3.16.2	FireMode Activ.Open				DigIN Slot0.2	1596	Defines location of fire mode activation on contact opening. Open Contact = Fire Mode Active Contact Closure = No Action <i>Also see Menu Structure P3.5.1.39.</i>
P3.16.3	FireMode Activ.Close				DigIN Slot0.1	1597	Defines location of Fire Mode activation on contact closing. Open Contact = No Action Contact Closure = Fire Mode Active <i>Also see Menu Structure P3.5.1.40.</i>
P3.16.4	FireMode Freq	Hz	0	Parameter P1.9 or P3.3.2	0	1598	Defines the frequency setpoint to be followed when fire mode is activated as defined by FireMode Active.Open (P3.16.2) or FireMode Activ.Close (P3.16.3) when FireMode FreqSource (P3.16.5) is defined as Fire Mode Frequency .

Structure	Parameter	Unit	Min	Max	Default	ID	Description
P3.16.5	FireMode FreqSource		FireMode Freq	Motor Pot Ref	FireMode Freq	1617	Selection of the frequency reference source to be followed when fire mode has been activated as defined by FireMode Activ.Open (P3.16.2) or FireMode Activ.Close (P3.16.3). Possible settings: 0 = Fire Mode Frequency (as defined by FireMode Freq (P3.16.4)) 1 = Preset Speeds 2 = Keypad 3 = Fieldbus 4 = AI1 5 = AI2 6 = AI1 + AI2 7 = PID1 8 = Motor Potentiometer
P3.16.6	FireMode Reverse				DigIN Slot0.1	1618	Defines location of the reverse command when Fire Mode is active as defined by FireMode Activ.Open (P3.16.2) or FireMode Activ.Close (P3.16.3). Open Contact = Forward Contact Closure = Reverse NOTE: This function has no effect in normal mode of operation. <i>Also see Menu Structure P3.5.1.4.</i>
M3.16.7	FireMode Status		Disabled	Test Mode	Disabled	1597	Displays the status of the Fire Mode as follows: 0 = Disabled 1 = Enabled 2 = Activated (Enabled and DI active) 3 = Test Mode
M3.16.8	FireMode Counter		0	4294967295		1679	Displays the number of times the Fire Mode has been activated. NOTE: This counter cannot be reset.

Application Settings (M3.17)

The Applications Settings contain specific application information and are presented in the following table:

Table 72: Application Settings.Information.

Structure	Parameter	Unit	Min	Max	Default	ID	Description
P3.17.1	Password		0	65000	0		Location for entering a password to the unit that will grant access to development parameters.
P3.17.2	kW/HP Selection		kW	HP	HP	1198	Defines the selection of the unit's power type parameters. Selectable for kilowatt or horse power.
P3.17.3	° C/° F Selection		°C	°F	°F	1197	Defines the selection of the unit's temperature type parameters. Selectable for Celsius or Fahrenheit.
P3.17.4	ByPass		Disabled	Electronic	Disabled	1809	Defines the bypass option connected to the drive. NOTE: To set the proper value for this parameter, it is not recommended to change this parameter. This parameter is set during the run of the Bypass Wizard (P1.21) Possible settings are as follows: 0 = Disabled 1 = Conventional 2 = Electronic NOTE: The setting of Disabled should also be used with all SED2 Migration Bypass Kits.

Bypass (M3.18)

The Bypass settings can only be accessed if **Bypass** (P3.17.4) is set to **Electronic**. The best way to set this is by executing the **Bypass Wizard** (P1.21). The Bypass settings contain specific information about the Electronic Bypass configuration.

The bypass settings are presented in the following table:

Table 73: Bypass Settings.



Structure	Parameter	Unit	Min	Max	Default	ID	Description
P3.18.1	Bypass Delay	s	1	30	1	1818	Defines the time from when bypass is activated until the M1 (bypass) contactor is pulled in and the motor begins to spin.
P3.18.2	AutoBypass		Disabled	Enabled	Disabled	1813	Enables parameter to the Auto Bypass feature. If enabled, when a selected fault (as defined by AutoByp Faults [P3.18.3]) occurs and the amount of time defined in AutoBypass Delay (P3.18.4) has passed, the unit automatically switches to bypass mode of operation. The M2 (Output) contactor will be opened, the M1 (Bypass) contactor will be closed, and line voltage will be connected directly to the motor. Motor will spin at full speed.
P3.18.3	AutoByp Faults					1812	Defines the authorized faults for the Auto Bypass feature to activate.
P3.18.4	AutoBypass Delay	s	1	30	1	1817	Defines the delay time from when the drive faults and the bypass is enabled.
P3.18.5	EssentServEnable		Disabled	Enabled	Disabled	1826	Enables parameter to the Essential Services feature. If enabled, when activated by Essential Services (P3.5.1.52), an Essential Services fault (83) displays. This is a version of Fire Mode that uses bypass instead of the drive for controlling the motor. The unit automatically switches to bypass mode of operation. The M2 (Output) contactor will be opened, the M1 (Bypass) contactor will be closed, and line voltage will be connected directly to the motor. Motor will spin at full speed.
P3.18.6	RemoteBypEnable		Disabled	Enabled	Disabled	1828	Enables parameter to the Remote Bypass feature. If enabled, when unit is placed in bypass mode, the M1 (Bypass) contactor opens/closes in accordance with Rem. Ctrl. Place (P3.2.1)

Diagnostics (M4)

Table 74: Diagnostics.

Menu and Parameter Group	Description
Active Faults (M4.1)	Display of currently active faults 1 and 2.
Reset Faults (P4.2)	Parameter to acknowledge/reset a fault.
Fault History (M4.4)	Display of up to 40 previous faults.
Total Counters (M4.6)	Display of the overall counters (not resettable).
Trip Counters (M4.7)	Display of the counters (resettable).
Software Info (M4.8)	Display of the software information.

Active faults (M4.1)

Active Faults will display any active fault. When a fault/faults display(s), the display with the name of the fault blinks. Press the  button to return to the Diagnostics menu. The Active Faults sub-menu shows the number of faults. Select the fault and press the  button to see the fault-time data. The memory can store a maximum of 10 active faults, in the order of occurrence.

Reset faults (P4.2)

When a fault has occurred, this parameter can be used to reset the drive from the fault condition.



NOTES:

1. Remove external control signal before resetting the fault to prevent unintentional restart of the drive.
2. The fault remains active until it is cleared with one of the following methods:
 - If a fieldbus communication is in use, command the Reset Fault object.
 - If a digital input is programmed for **Fault Reset Close** (P3.5.1.9) or **Fault Reset Open** (P3.5.1.10), toggle the digital input.
3. The default setting for **Fault Reset Close** (P3.5.1.9) is digital input 4 (DigIN SlotA.4)
 - a. Press and hold the Back/Reset button on the keypad for one second.
 - b. Enter the Diagnostics (M4) menu, enter **Reset Faults** (P4.2) parameter, and select **Reset Faults**.

Structure	Parameter	Description
P4.2	Reset Faults	Resets/acknowledges alarms/faults that are waiting to be reset. Active faults cannot be reset. NOTE: This same action can be done by pressing and holding the Back/Reset button for approximately 1 second.

Fault History (M4.4)

Fault history can contain a maximum number of 40 faults. Once the count of 40 has been reached, the FIFO method is used to store the newest faults. On each fault in memory, you will also find additional information about the drive when the fault occurred. See *Chapter 5, Fault Tracing* for more information.

Total Counters (M4.6)

Total Counters contain all the totalized counters for energy usage, run time, power on time, and even start command count. These setting are not resettable.

The total counters are presented in the following table:

Table 75: Total Counters.

Structure	Parameter	Unit	Min	Max	Default	ID	Description
M4.6.1	Energy Counter	Varies				2291	The amount of energy taken from the supply. NOTE: This is not resettable. Highest energy unit that the display shows is MW (megawatts). If the counter scrolls past 999.9 MW, no unit will display. See Energy Counter (P4.7.1) for resettable version.
M4.6.3	Operating Time	y d hh:mm				2298	Displays the control units operating time in years, days, hours:minutes. NOTE: This is not resettable. See Operating Time (P4.7.3) for resettable version.
M4.6.7	Run Time	y d hh:mm				2293	Displays the motor run time in years, days, hours:minutes
M4.6.11	Power On Time	y d hh:mm					Displays the power on time in years, days, hours:minutes
M4.6.15	Start Cmd Counter					2295	Displays the number of times the power unit has been started.

Trip Counters (M4.7)

Trip Counters contain the reset objects for energy usage and time clock, and are presented in the following table:

Table 76: Trip Counters.

Structure	Parameter	Unit	Min	Max	Default	ID	Description
M4.7.1	Energy Counter	Varies				2296	The amount of energy taken from the supply. NOTE: This is resettable. Highest energy unit that the display shows is MW (megawatts). If the counter scrolls past 999.9 MW, no unit will display. See Energy Counter (M4.6.1) for non-resettable version.
M4.7.3	Operating Time	y d hh:mm				2299	Displays the control units operating time in years, days, hours:minutes. NOTE: This is resettable. See Operating Time (M4.6.3) for non-resettable version.

Software Info (M4.8)

Software Info contains software/firmware specific information. **Software Package (M4.8.1)** is vital information for Technical Support when troubleshooting issues.

The software info settings are presented in the following table:

Table 77: Software Information Settings.

Structure	Parameter	Unit	Min	Max	Default	ID	Description
M4.6.1	Software Package				FW0183V012	2524	Software Package (Drive Firmware Revision String).
M4.8.4	System Load	%	0	-100		2300	Load on control unit CPU.
M4.8.5	Application Name				HVAC	2525	Name of Application.
M4.8.6	Application ID				1114	837	Application ID.
M4.8.7	Application Ver.				117	838	Application Version.

I/O and Hardware (M5)

Under this menu are the following sections related to the I/O and hardware of the drive:

Table 78: I/O and Hardware.

Menu and Parameter Group	Description
Basic IO (M5.1)	Provides status of I/O found on Slot A and Slot B.
Slot C (M5.2)*	Provides status of I/O found on Slot C.
Slot D (M5.3)*	Provides status of I/O found on Slot D.
Slot E (M5.4)*	Provides status of I/O found on Slot E.
Real Time Clock (M5.5)	Configuration and status of the real time clock.
Power Unit Settings (M5.6)	Configuration and status of the fan and sine filter.
Keypad (M5.7)	Configuration of keypad specific information.
RS-485 (M5.8)	Configuration and status of the RS-485 type fieldbus protocols.
Ethernet (M5.9)	Configuration and status of the Ethernet type fieldbus protocols.

* If an option board has been installed in the slot, the name of this menu will change to the card name (such as, OPTB5).

Basic I/O (M5.1)

Displays the status of the Basic Slot A and Slot B I/O. See *I/O Configuration (M3.5)* for configuration information of the Basic I/O.

Table 79: Basic Slot A and Slot B I/O.

Structure	Parameter	Unit	Min	Max	Default	ID	Description
M5.1.1	Digital Input 1		OFF	ON		2502	Status of Digital Input 1 Signal
M5.1.2	Digital Input 2		OFF	ON		2503	Status of Digital Input 2 Signal
M5.1.3	Digital Input 3		OFF	ON		2504	Status of Digital Input 3 Signal
M5.1.4	Digital Input 4		OFF	ON		2505	Status of Digital Input 4 Signal
M5.1.5	Digital Input 5		OFF	ON		2506	Status of Digital Input 5 Signal
M5.1.6	Digital Input 6		OFF	ON		2507	Status of Digital Input 6 Signal
M5.1.7	Analog Input 1 Mode		0...20 mA	0...10 Vdc	0...0 Vdc	2508	Shows the selected mode (with jumper) for analog input signal 1 = 0...20 mA 3 = 0...10 Vdc
M5.1.8	Analog Input 1	%	0	100	0	2509	Status of Analog Input 1 Signal
M5.1.9	Analog Input 2 Mode		0...20 mA	0...10 Vdc	0...20 mA	2510	Shows the selected mode (with jumper) for analog input signal 1 = 0...20 mA 3 = 0 ...10 Vdc
M5.1.10	Analog Input 2	%	0	100	0	2511	Status of Analog Input 2 Signal
M5.1.11	Analog Output 1 Mode		0...20 mA	0...10 Vdc	0...20 mA	2512	Shows the selected mode (with jumper) for analog input signal 1 = 0...20 mA 3 = 0...10 Vdc
M5.1.12	Analog Output 1	%	0	100		2513	Status of Analog Output 1 Signal
M5.1.13	Relay Output 1		OFF	ON		2514	Status of Relay Output 1 Signal
M5.1.14	Relay Output 2		OFF	ON		2515	Status of Relay Output 2 Signal
M5.1.15	Relay Output 3		OFF	ON		2516	Status of Relay Output 3 Signal

Slot C (M5.2)

Displays the status of the available I/O for the option card installed in Slot C. The available parameters change depending upon the option card installed. See the *I/O Option Board Type "B" User's Manual* (DPD01158) for a list of available option cards and their I/O types.

Table 80: I/O Slot C.

Structure	Parameter	Min.	Max.	Default	Description
M5.2.1	I/O Monitor (depends upon the option card installed in slot C.)				
M5.2.4	Software Info				
M5.2.4.1	Version Number	Varies	Varies	Varies	Displays the version of the option board.
M5.2.4.2	Board Status				Displays status of the option board.

Slot D (M5.3)

Displays the status of the available I/O for the option card installed in Slot D. The available parameters change depending upon the option card installed. See the *I/O Option Board Type "B" User's Manual* (DPD01158) for a list of available option cards and their I/O types.

Table 81: I/O Slot D.

Structure	Parameter	Min.	Max.	Default	Description
M5.2.1	I/O Monitor (depends upon the option card installed in slot D.)				
M5.2.4	Software Info				
M5.2.4.1	Version Number	Varies	Varies	Varies	Displays the version of the option board.
M5.2.4.2	Board Status				Displays status of the option board.

Slot E (M5.4)

Displays the status of the available I/O for the option card installed in Slot E. The available parameters change depending upon the option card installed. See the *I/O Option Board Type "B" User's Manual* (DPD01158) for a list of available option cards and their I/O types.

Table 82: I/O Slot E.

Structure	Parameter	Min.	Max.	Default	Description
M5.2.1	I/O Monitor (depends upon the option card installed in slot E.)				
M5.2.4	Software Info				
M5.2.4.1	Version Number	Varies	Varies	Varies	Displays the version of the option board.
M5.2.4.2	Board Status				Displays status of the option board.

Real time clock (M5.5)

Table 83: Real Time Clock Settings.

Structure	Parameter	Unit	Min	Max	Default	ID	Description
M5.5.1	Battery State		Not Installed	Change Battery	Installed	2205	Status of battery 1 = Not installed 2 = Installed 3 = Change Battery
M5.5.2	Time	hh:mm:ss				2201	Current time of day.
M5.5.3	Date	dd.mm				2202	Current date.
M5.5.4	Year	yyyy				2203	Current year.
M5.5.5	Daylight Saving		Off	Russia	Off	2204	Daylight Saving Rule 1 = Off 2 = EU 3 = US 4 = Russia

Power unit settings (M5.6)

Fan (M5.6.1)

The cooling fan operates in Optimized or Always-On mode. In the Optimized mode, fan speed is controlled according to the drive's internal logic that receives data from temperature measurements; the fan stops five minutes after the drive is in a ready state. In Always-On mode, the fan runs at full speed, without stopping.

Table 84: Cooling Fan Settings.

Structure	Parameter	Unit	Min	Max	Default	ID	Description
P5.6.1.1	Fan Control Mode		Always On	Optimized	1	2377	Defines the heat sink cooling fan mode: 0 = Always On 1 = Optimized
M5.6.1.5	Fan Lifetime	h				849	Displays the cooling fan's run time in hours. NOTE: Fan Lifetime Reset (P5.6.1.7) will reset this value.
P5.6.1.6	Fan Lifetime Alarm Lim.	h	0	200000	50000	824	Defines the alarm limit for the cooling fan's useful life.
P5.6.1.7	Fan Lifetime Reset					823	Reset parameter for the Fan Lifetime (M5.6.1.5)

Sine Filter (M5.6.4)

Sine filter support restricts overmodulation depth and prevents thermal management functions from decreasing switching frequency.

Table 85: Sine Filter Settings.

Structure	Parameter	Unit	Min	Max	Default	ID	Description
P5.6.4.1	Sine Filter		Disabled	Enabled	Disabled	2527	Enable parameter for the Sine Filter.

Keypad (M5.7)

Configuration of the keypad-specific items such as contrast, backlight time, and the default screen are completed in this section.

In Firmware FW0183V011 and earlier, the display does not default to any particular place. Whatever was last entered on the screen will remain there until changed. However, in FW0183V012 and later, the screen defaults to the Multimonitor display after two minutes of inactivity of the keypad. If you prefer a different default screen, use the parameters in this section to make those changes.

Table 86: Keypad Configuration Settings.

Structure	Parameter	Unit	Min	Max	Default	ID	Description
P5.7.1	Timeout Time	min	0	60	0	804	Time until display returns to page defined in the Default Page (P5.7.2) 0 = Not used
P5.7.2	Default Page		None	Multimonitor	Multimonitor	2318	Defines the default page to appear after Timeout Time (P5.7.1) has passed. 0 = None 1 = Enter Menu Index (see Menu Index (P5.7.3)) 2 = Main Menu 3 = Control Page 4 = Multimonitor NOTE: Recommended to use Multimonitor.
P5.7.3	Menu Index				0.0.0.0.0	2499	Defines the parameter (in accordance with menu structure) to be displayed as default page when Default Page (P5.7.2) is set to a value of Enter Menu Index . For example, if Output Frequency (M2.2.1) is to be displayed, set this parameter to a value of 2.2.1.0.0.
P5.7.4	Contrast	%	30	70	50	830	Set the contrast of the display.
P5.7.5	Backlight Time	min	0	60	5	818	Defines the amount of time of keypad inactivity that must occur before the backlight of the display turns off. 0 = backlight always ON.

Example:

To set the drive's display to default to the Output Frequency display after five minutes, complete the following steps:

1. Set **Timeout Time** (P5.7.1) to a value of **5**.
2. Set **Default Page** (P5.7.2) to a value of **Enter Menu Index**.
3. Set **Menu Index** (P5.7.3) to a value of **2.2.1**.

RS-485 (M5.8)

The RS-485 settings are used to define and configure the desired the fieldbus protocol.

The wiring for RS-485 networks is the same no matter what fieldbus protocol is used. Connect to the appropriate terminals (A = negative; B = positive) as shown in the figure below:

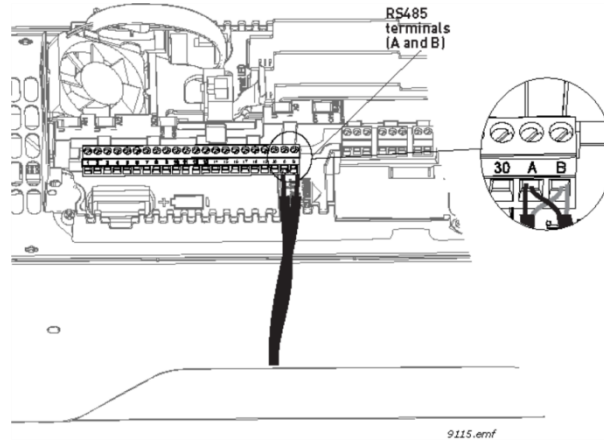

Figure 34: Connecting the RS-485 Cable.

If the Siemens BT300 HVAC Drive is the last device on the bus, the bus termination may be required. See the figure below for enabling to bus termination:

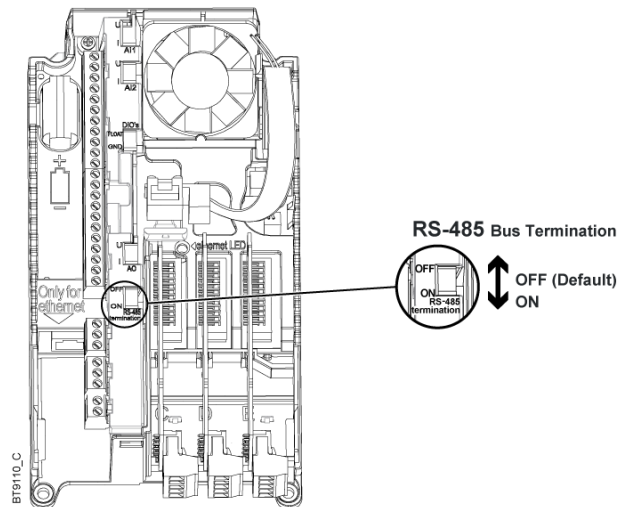

Figure 35: Bus Termination.

Common Settings (M5.8.1)

Common settings are presented in the following table:

Table 87: Common Settings.

Structure	Parameter	Min.	Max.	Default	ID	Description
P5.8.1.1	Protocol	No Protocol	Modbus RTU	No Protocol	2208	<p>Defines the RS-485 base fieldbus protocol to be used:</p> <p>0 = No Protocol 1 = N2 2 = BACnet MS/TP 3 = P14 = Modbus RTU</p> <p>NOTE: A new menu will be accessible at M5.8.3 depending upon the protocol selected. Configuration for protocol communications will be within that menu.</p> <p>NOTE: This selection enables monitoring only. If control (start/stop and speed reference) is to be from fieldbus, then Ctrl. Place Auto (P3.3.1) must be set to FieldbusCTRL.</p>

N2 (M5.8.3)

The N2 communications protocol is used by Johnson Controls and others to connect terminal unit controllers to supervisory controllers. It is open to any manufacturer and based upon a simple ASCII protocol widely used in the process control industry.

The physical characteristics of the N2 bus is an RS-485 3wire connection, with a maximum of 100 devices over a 4,000 foot distance, running at 9,600 bps. Logically, the N2 is a master-slave protocol; the supervisory controller is normally the master. Data is partitioned into common HVAC control objects, such as analog input, analog output, binary input, and binary output. N2 messaging supports the reading, writing, and overriding of these points. Additionally, there are messages defined to perform uploads and downloads of devices as well as to direct memory reads and writes.

The N2 fieldbus protocol supports the following point types:

- Analog Input (AI)
- Analog Output (AO)
- Binary Input (BI)
- Binary Output (BO)
- Internal Integer (ADI)

If **Protocol** (P5.8.1.1) is set to a value of **N2**, then configuration and status parameters related to the N2 fieldbus protocol are made available as listed in the Parameters and Monitoring sections below.

Parameters (M5.8.3.1)

The following configuration parameters are available for the N2 fieldbus protocol:

Table 88: N2 Protocol Parameters.

Menu	Parameter	ID	Unit	Mn.	Max.	Default	Description
P5.8.3.1.1	Device Address	2350		1	255	1	Defines the unique slave address to be used by the drive on the N2 network.
P5.8.3.1.2	Communications Timeout	2351	s	0	255	10	Defines the amount of time in which a packet is not received before a communications timeout is faulted/alarmed.

Monitoring (M5.8.3.2)

The following monitoring values are available for the N2 fieldbus protocol:

Table 89: N2 Fieldbus Protocol Monitoring.

Menu	Parameter	ID	Min	Max	Description
M5.8.3.2.1	Fieldbus Protocol Status	2399	Initializing	Faulted	Displays the current protocol status as follows: 0 = Initializing 1 = Stopped 2 = Operational 3 = Faulted
M5.8.3.2.2	Communication Status	2400	0.0	99.999	Displays the number of bad frames and good messages in the following format: xx.yyy where xx indicates the bad frames and yyy indicates the good messages.
M5.8.3.2.3	Invalid Data	2041			Active if one or more of the fields in a fieldbus packet contains a value that is out of the expected range.
M5.8.3.2.4	Invalid Commands	2402			Displays the number of commands that are not appropriate for the field or record.
M5.8.3.2.5	Command NACK	2403			Displays the number of negative acknowledgments due to problems with the device, so the command was ignored.
M5.8.3.2.6	Control Word	2402			Displays the control word in a bit coded format as follows: B0 = Start/Stop B2 = Fault Reset
M5.8.3.2.7	Status Word	2405			Displays the status word in a bit coded format as follows:

N2 Point Map

Analog Inputs (AI)

All analog inputs (AI) points have the following features:

- Support Change of State (COS) reporting based on high and low warning limits.
- Support Change of State (COS) reporting based on high and low alarm limits.
- Support Change of State (COS) reporting based on override status.
- Always considered reliable and never out of range.
- Writing alarm and warning limit values beyond the range that can be held by the drive's internal variable will result in having the limit replaced by the **Invalid Float** value even though the message is acknowledged. The net results will be the inactivation of the alarm or warning (the same as if the original out of range value was used).
- Overriding is supported from the standpoint that the "Override Active" bit will be set and the value reported to the N2 network will be the overridden value. However, the value in the drive remains unchanged. Therefore, the N2 system should be set up to prevent overriding AI point or have an alarm condition activated when an AI point is overridden.
- Overriding an AI point with a value beyond the limit allowed by the drive's internal variable will result in an **Invalid Data** error and the override status and value will remain unchanged.

Table 90: N2 Analog Inputs.

NPT	NPA	Description	Units	Note
AI	1	Speed Setpoint	Hz	2 decimal places
AI	2	Output Frequency	Hz	2 decimal places
AI	3	Motor Speed	RPM	0 decimal places
AI	4	Load (power)	%	1 decimal
AI	5	Megawatt Hours	MWh	Total counter
AI	6	Motor Current	A	2 decimal places
AI	7	Bus Voltage	V	0 decimal places
AI	8	Motor Volts	V	1 decimal place
AI	9	Heatsink Temperature	° C	0 decimal places
AI	10	Motor Torque	%	1 decimal place
AI	11	Operating Days (trip)	Day	0 decimal places
AI	12	Operating Hours (trip)	Hour	0 decimal places
AI	13	Kilowatt Hours (trip)	kWh	Trip Counter
AI	14	Torque Reference	%	1 decimal place
AI	15	Motor Temperature Rise	%	1 decimal place
AI	16	FBProcessDataOut1*		0 decimal places
AI	17	FBProcessDataOut2*		0 decimal places
V	18	FBProcessDataOut3*		0 decimal places
V	19	FBProcessDataOut4*		0 decimal places
AI	20	FBProcessDataOut5*		0 decimal places
AI	21	FBProcessDataOut6*		0 decimal places
AI	22	FBProcessDataOut7*		0 decimal places
AI	23	FBProcessDataOut8*		0 decimal places

Binary Inputs (BI)

All binary inputs (BI) points have the following features:

- Support Change of State (COS) reporting based on current state.
- Support Change of State (COS) reporting based on alarm condition.
- Support Change of State (COS) reporting based on override status.
- Always considered reliable.
- Overriding is supported from the standpoint that the “Override Active” bit will be set and the value reported to the N2 network will be the overridden value. However, the value in the drive remains unchanged. Therefore, the N2 system should be set up to disallow overriding BI point or have an alarm condition activated when a BI point is overridden.

Table 91: N2 Binary Inputs.

NPT	NPA	Description	0 =	1 =
BI	1	Ready	Not Ready	Ready
BI	2	Run	Stop	Run
BI	3	Direction	Clockwise	Counterclockwise

NPT	NPA	Description	0 =	1 =
BI	4	Faulted	Not Faulted	Faulted
BI	5	Alarm	Not Alarm	Alarm
BI	6	Ref. Frequency reached	False	True
BI	7	Motor running zero speed	False	True
BI	8	Flux ready	Not Ready	Ready

Analog Outputs (AO)

All analog outputs (AO) points have the following features:

- Support Change of State (COS) reporting based on override status.
- Always considered reliable.
- Overriding of the AO points is the method used to change a value. Overriding an AO point with a value beyond the limit allowed by the drive's internal variable will result in an `Invalid Data` error and the override status and value will remain unchanged. If the overridden value is beyond the drive's parameter limit but within the range that will fit in the variable, an acknowledge response is given and the value will be internally clamped to its limit.

Table 92: N2 Analog Outputs.

NPT	NPA	Description	Units	Note
AO	1	Comms Speed	%	2 decimal places
AO	2	Current Limit	A	2 decimal places
AO	3	Minimum Speed	Hz	2 decimal places
AO	4	Maximum Speed	Hz	2 decimal places
AO	5	Accel Time	s	1 decimal place
AO	6	Decel Time	s	1 decimal place
AO	7	FBProcessDataIn1*		2 decimal places
AO	8	FBProcessDataIn2*		2 decimal places
AO	9	FBProcessDataIn3*		2 decimal places
AO	10	FBProcessDataIn4*		2 decimal places
AO	11	FBProcessDataIn5*		2 decimal places
AO	12	FBProcessDataIn6*		2 decimal places
AO	13	FBProcessDataIn7*		2 decimal places
AO	14	FBProcessDataIn8*		2 decimal places
AO	15	Any parameter Read/Write		Depends on parameter

Binary Outputs (BO)

All binary outputs (BO) points have the following features:

- Support Change of State (COS) reporting based on override status.
- Always considered reliable.
- Overriding BO points control the drive. These points are input commands to the drive. When released, the drive's internal value remains at its last overridden value.

Table 93: N2 Binary Outputs.

NPT	NPA	Description	0 =	1 =
BO	1	Comms Start/Stop	Stop	Start
BO	2	Comms Forward/Reverse	Forward	Reverse
BO	3	Reset Fault	N/A	Reset
BO	4	Stop mode information 1		
BO	5	Stop mode information 2		
BO	6	Force ramp to zero		
BO	7	Freeze ramp		
BO	8	Reference to zero		
BO	9	BusCtrl		
BO	10	BusRef		

Internal Integers (ADI)

All Internal Integer (ADI) points have the following features:

- Do not support Change of State (COS) reporting.
- Can be overridden and the “Override Active” bit will be set. However, the internal value is unchanged (read only).

Table 94: Internal Integers.

NPT	NPA	Description	Units
ADI	1	Active Fault Code	
ADI	2	Control Word	
ADI	3	Status Word	
ADI	4	Any Parameter ID	

N2 Protocol Quick Setup

For monitoring of objects using the N2 protocol, complete the following changes:

1. Select: **Main Menu > I/O and Hardware (M5) > RS-485 (M5.8) > Common Settings (M5.8.1) > Protocol (P5.8.1.1) > Edit.**

2. Select **N2** from the list and press the  button.

3. Select: **Main Menu > I/O and Hardware (M5) > RS-485 (M5.8) > N2 (M5.8.3) > Parameters (M5.8.3.1) > Device Address (P5.8.3.1.1) > Edit.**

4. Enter the desired network device address and press the  button.

5. Select: **Main Menu > I/O and Hardware (M5) > RS-485 (M5.8) > N2 (M5.8.3) > Parameters (M5.8.3.1) > Comm. Timeout (P5.8.3.1.2) > Edit.**

6. Enter the desired time for drive to monitor for a communications loss and press the  button. A value of **0** disables this monitoring.

For commanding Start/Stop and Speed Reference using the N2 protocol, complete the following steps:

1. Complete all settings required for Monitoring as listed above.
2. Set **Ctrl. Place Auto** (P3.2.1) to a value of **FieldbusCTRL**.

For commanding Start/Stop through the N2 protocol and Speed Reference through an Analog Input, complete the following changes:

1. Complete all settings required for Monitoring as listed above.
2. Set **Ctrl. Place Auto** (P3.2.1) to a value of **FieldbusCTRL**.
3. Set **FieldbusCtrl Ref** (P3.3.9) to a value of **AI1** or **AI2** (depending upon which AI is in use).

For commanding Start/Stop through a Digital Input and Speed Reference through the N2 protocol, complete the following changes:

1. Complete all settings required for Monitoring as listed above.
2. Set **Ctrl. Place Auto** (P3.2.1) to a value of **I/O Control**.
3. Set **I/O A Ctrl Ref** (P3.3.3) to a value of **Fieldbus**.

BACnet MS/TP (M5.8.3)

BACnet stands for Building Automation and Control Networks. It is the common name for the communications standard ISO 16484-5 which defines the methods and the protocol for cooperating building automation devices to communicate. Devices can be designed to operate using BACnet communication protocol, as well as utilizing BACnet protocol to communicate between systems. BACnet is an internationally accepted protocol for building automation and control over a communications network.

BACnet provide a method by which computer-based control equipment from different manufacturers can work together, or “interoperate”. To achieve, components must be able to exchange and understand BACnet data messages.

The Siemens BT300 is standard equipped with BACnet support.

If **Protocol** (P5.8.1.1) is set to a value of **BACnet MS/TP**, then configuration and status parameters related to the BACnet MS/TP fieldbus protocol are made available.

Parameters (M5.8.3.1)

The following configuration parameters are available for the BACnet MS/TP fieldbus protocol:

Table 95: BACnet MS/TP Parameters.

Menu	Parameter	ID	Unit	Min	Max	Default	Description
P5.8.3.1.1	Baud Rate	2392	bps	9600	76800	9600	on the network as follows: 1 = 9600 2 = 19200 3 = 38400 4 = 76800
P5.8.3.1.2	Autobauding	2330		Disabled	Enabled	Disabled	Defines if autobauding can be used to configure the Baud Rate (P5.8.3.1.1).
P5.8.3.1.3	MAC Address	2331		1	127	1	Defines the unique device address for the RS-485 network.
P5.8.3.1.4	Instance Number	2332		0	4194303	0	Defines the unique device address for the IP network if a IP-MS/TP router is used.
P5.8.3.1.5	Communications Timeout	2333	s	0	65535	10	Defines the amount of time in which a packet is not received before a communications timeout is faulted/alarmed.

Monitoring (M5.8.3.2)

The following monitoring values are available for the BACnet MS/TP fieldbus protocol:

Table 96: BACnet MS/TP Monitoring.

Menu	Parameter	ID	Min	Max	Description
M5.8.3.2.1	Fieldbus Protocol Status	2393	Initializing	Faulted	Displays the current protocol status as follows: 0 = Initializing 1 = Stopped 2 = Operational 3 = Faulted
M5.8.3.2.2	Communication Status	2394	0.0	99.999	Displays the number of bad frames and good messages in the following format: xx.yyy where xx indicates the bad frames and yyy indicates the good messages.
M5.8.3.2.3	Actual Instance	2395			Displays the actual device BACnet instance number.
M5.8.3.2.4	Fault Code	2396	None	Baud Rate Fault	Displays the fieldbus communications fault status as follows: 0 = None 1 = Sole Master 2 = Duplicated MAC ID 3 = Baud Rate Fault
M5.8.3.2.5	Control Word	2397			Displays the control word in a bit-coded format as follows: B0 = Start/Stop B2 = Fault Reset
M5.8.3.2.6	Status Word	2398			Displays the status word in a bit-coded format as follows: B0 = Ready B2 = Fwd/Rev B4 = Alarm B6 = Zero Speed B3 = Fault B5 = At Reference

BACnet Object List

The BACnet object list was enhanced with FW0183V012. If using Firmware Revision FW0183V011 or earlier, see the *Siemens BT300 HVAC Drive Protocol Installation and User Manual* (DPD01162) for further information.

Analog Inputs (AI)

The analog inputs support the following BACnet properties:

- Event State
- Object Identifier
- Object Name
- Object Type
- Out of Service
- Present Value
- Status Flags
- Units

Table 97: BACnet Analog Inputs.

Instance ID	Object Name	Description	Units	PV Access	Menu
AI_0	ANALOG IN 1	This is the value of Analog Input 1	PCT	R	M2.2.13
AI_1	ANALOG IN 2	This is the value of Analog Input 2	PCT	R	M2.2.14

Binary Inputs (BI)

The binary inputs support the following BACnet properties:

- Active Text
- Event State
- Inactive Text
- Object Identifier
- Object Name
- Object Type
- Out of Service
- Present Value
- Status Flags

Table 98: BACnet Binary Inputs.

Instance ID	Object Name	Description	Active/Inactive Text	PV Access	Menu
BI_0	DI1 STATUS	Status of digital input 1 signal.	ON/OFF	R	M5.1.1
BI_1	DI2 STATUS	Status of digital input 2 signal.	ON/OFF	R	M5.1.2
BI_2	DI3 STATUS	Status of digital input 3 signal.	ON/OFF	R	M5.1.3
BI_3	DI4 STATUS	Status of digital input 4 signal.	ON/OFF	R	M5.1.4
BI_4	DI5 STATUS	Status of digital input 5 signal.	ON/OFF	R	M5.1.5
BI_5	DI6 STATUS	Status of digital input 6 signal.	ON/OFF	R	M5.1.6

Analog Outputs (AO)

The analog outputs support the following BACnet properties:

- Event State
- Object Identifier
- Object Name
- Object Type
- Out of Service
- Present Value
- Priority Array
- Relinquish Default
- Status Flags
- Units

Table 99: BACnet Analog Outputs.

Instance ID	Object Name	Description	Units	PV Access	Menu
AO_0	ANALOG OUT 1	Analog output command, if configured.	PCT	C	M2.2.15

Binary Outputs (BO)

The binary outputs support the following BACnet properties:

- Active Text
- Event State
- Inactive Text
- Object Identifier
- Object Name
- Object Type
- Out of Service
- Present Value
- Priority Array
- Relinquish Default
- Status Flags

Table 100: BACnet Binary Outputs.

Instance ID	Object Name	Description	Active/Inactive Text	PV Access	Menu
BO_0	RO1 CMD	This object is the command of the state for Relay Output 1	ON/OFF	C	FB ControlWord B13
BO_1	RO2 CMD	This object is the command of the state for Relay Output 2	ON /OFF	C	FB ControlWord B14
BO_2	RO3 CMD	This object is the command of the state for Relay Output 3	ON /OFF	C	FB ControlWord B15
BO_3	RUN ENABLE	Run Enable	ENABLE / DISABL	C	
BO_4	CMD RUN STOP	Run Stop Command	RUN / STOP	C	FB ControlWord B0
BO_5	CMD FWD REV	Forward Reverse Command	REVRSE / FORWRD	C	FB ControlWord B1

Analog Values (AV)

The analog value support the following BACnet properties:

- Event State
- Object Identifier
- Object Name
- Object Type
- Out of Service
- Present Value
- Priority Array*
- Relinquish Default*
- Status Flags
- Units

* For commandable values only.

Table 101: BACnet Analog Values.

Instance ID	Object Name	Description	Units	PV Access	Menu
AV_0	SPEED REF	Speed Reference, % of nominal speed.	PCT	C	
AV_1	FREQ STPT	Frequency Setpoint	Hz	R	
AV_2	OUTPUT PCT	Output Frequency in %	PCT	R	
AV_3	OUTPUT FREQ	Output Frequency	Hz	R	M2.2.1
AV_4	MOTOR SPEED	Motor Speed	rpm	R	M2.2.3
AV_5	MOTOR CRRNT	Motor Current	A	R	M2.2.4
AV_6	MOTOR VLTG	Motor Voltage	V	R	M2.2.9
AV_7	MOTOR TORQUE	Motor Torque	PCT	R	M2.2.5
AV_8	MOTOR TEMP	Motor Temperature	PCT	R	M2.2.12
AV_9	LOAD	Motor Shaft Power	PCT	R	M2.2.7
AV_10	KW HOURS	Kilowatt Hours (Resettable)	kWh	R	
AV_11	KW HOURS TOT	Kilowatt Hours (Non-Resettable)	kWh	R	
AV_12	OPER DAYS	Operating Days (Resettable)	Day	W	
AV_13	OPER HOURS	Operating Hours (Resettable)	Hour	W	
AV_14	DC LINK VLTG	DC Link Voltage	V	R	M2.2.10
AV_15	DRIVE TEMP	Heatsink Temperature	DEG	R	M2.2.11
AV_16	ACTIVE FAULT	Active Fault Code		R	M2.2.18
AV_17	LAST FAULT 1	Most recent fault		R	
AV_18	LAST FAULT 2	Second most recent fault		R	
AV_19	LAST FAULT 3	Third most recent fault		R	
AV_20	FBDATAOUT 01	Fieldbus Process Data Out 1		R	P3.6.1
AV_21	FBDATAOUT 02	Fieldbus Process Data Out 2		R	P3.6.2
AV_22	FBDATAOUT 03	Fieldbus Process Data Out 3		R	P3.6.3
AV_23	FBDATAOUT 04	Fieldbus Process Data Out 4		R	P3.6.4
AV_24	FBDATAOUT 05	Fieldbus Process Data Out 5		R	P3.6.5
AV_25	FBDATAOUT 06	Fieldbus Process Data Out 6		R	P3.6.6
AV_26	FBDATAOUT 07	Fieldbus Process Data Out 7		R	P3.6.7
AV_27	FBDATAOUT 08	Fieldbus Process Data Out 8		R	P3.6.8
AV_28	FB DATA IN 1	Fieldbus Process Data In 1		C	M2.8.3
AV_29	FB DATA IN 2	Fieldbus Process Data In 2		C	M2.8.4
AV_30	FB DATA IN 3	Fieldbus Process Data In 3		C	M2.8.5
AV_31	FB DATA IN 4	Fieldbus Process Data In 4		C	M2.8.6
AV_32	FB DATA IN 5	Fieldbus Process Data In 5		C	M2.8.7
AV_33	FB DATA IN 6	Fieldbus Process Data In 6		C	M2.8.8
AV_34	FB DATA IN 7	Fieldbus Process Data In 7		C	M2.8.9
AV_35	FB DATA IN 8	Fieldbus Process Data In 8		C	M2.8.10
AV_36	FBCTRLWORDLO	Fixed control word first 16 bits		C	M2.8.1

Instance ID	Object Name	Description	Units	PV Access	Menu
AV_37	FBCTRLWORDHI	Fixed control word last 16 bits		C	M2.8.1
AV_38	FBSTATWORDLO	Fixed status word first 16 bits		R	M2.8.11
AV_39	FBSTATWORDHI	Fixed status word last 16 bits		R	M2.8.11
AV_40	MIN FREQ	Minimum Frequency	Hz	W	P3.3.1
AV_41	MAX FREQ	Maximum Frequency	Hz	W	P3.3.2
AV_42	ACCEL TIME	Acceleration Time (1)	s	W	P3.4.2
AV_43	DECEL TIME	Deceleration Time (1)	s	W	P3.4.3
AV_44	CURRENT LMT	Current Limit	A	W	P3.1.1.7
AV_45	MTRNOM CRRNT	Motor Nominal Current	A	W	P3.1.1.4
AV_46	MTRNOM POWER	Motor Nominal Power	HP	W	P3.1.1.6
AV_47	MTRNOM SPEED	Motor Nominal Speed	rpm	W	P3.1.1.3
AV_48	MTRNOM VLTG	Motor Nominal Voltage	V	W	P3.1.1.1
AV_49	MTRNOM FREQ	Motor Nominal Frequency	Hz	W	P3.1.1.2
AV_50	MOTOR COSPHI	Motor COSPHI		W	P3.1.1.5
AV_51	BYPASS	Bypass Type		R	P3.17.4
AV_52	BYP SAFESTAT	Bypass Safety Status		R	
AV_53	BYP RUN TIME	Bypass Run Time		R	
AV_54	PID1 GAIN		%	R	P3.12.1.1
AV_55	PID1 I TIME		s	R	P3.12.1.2
AV_56	PID1 D TIME		s	R	P3.12.1.3
AV_57	PID1 STATUS			R	M2.4.5
AV_58	PID1 STPT			R	M2.4.1
AV_59	PID1 FDBK			R	M2.4.2
AV_60	PID1 OUTPUT			R	M2.4.4
AV_61	PID2 GAIN			R	P3.13.1.3
AV_62	PID2 I TIME		s	R	P3.13.1.4
AV_63	PID2 D TIME		s	R	P3.13.1.5
AV_64	PID2 STATUS			R	M2.5.5
AV_65	PID2 STPT			R	M2.5.1
AV_66	PID2 FDBK			R	M2.5.2
AV_67	PID2 OUTPUT		PCT	R	M2.5.4
AV_68	ANY PARAM	ID number that is use in AV71		W	
AV_69	ANY VALUE	Value of ID defined by AV70		W	

Binary Values (BV)

The binary outputs support the following BACnet properties:

- Active Text
- Event State
- Inactive Text
- Object Identifier
- Object Name
- Object Type
- Out of Service
- Present Value
- Priority Array*
- Relinquish Default*
- Status Flags

Table 102: BACnet Binary Values.

Instance ID	Object Name	Description	Active/Inactive Text	PV Access	Menu
BV_0	READY STATE	Status of the Ready State.	READY/NOTRDY	R	V2.2.17
BV_1	RUNENBL STAT	Status of Run Enable, regardless of the control source.	ENABLE/DISABL	R	V2.2.17
BV_2	RUNSTP STAT	Status of Run Stop, regardless of the control source.	RUN/STOP	R	V2.2.17
BV_3	FWD REV STAT	Status of Forward/ Reverse, regardless of the control source.	REVRSE/FORWRD	R	
BV_4	FAULT STATUS	Status of Fault, regardless of the control source.	FAULT/NOFLT	R	
BV_5	ALARM STATUS	Status of Alarm, regardless of the control source.	ALARM/NORMAL	R	
BV_6	AT ZERO	Motor is running at Zero speed.	TRUE/FALSE	R	
BV_7	AT SETPOINT	Motor is running at Setpoint.	TRUE/FALSE	R	
BV_8	RO1 STATUS	Status of relay output 1.	ON/OFF	R	P5.1.13
BV_9	RO2 STATUS	Status of relay output 2.	ON/OFF	R	P5.1.14
BV_10	RO3 STATUS	Status of relay output 3.	ON/OFF	R	P5.1.15
BV_11	M1 STATUS	Status of M1 contactor (if e-bypass enabled).	CLOSED/OPEN	R	
BV_12	M2 STATUS	Status of M2 contactor (if e-bypass enabled).	CLOSED/OPEN	R	
BV_13	FBDATAOUT1B0	Fieldbus Process Data Out 1 Bit 0	ON/OFF	R	
BV_14	FBDATAOUT1B1	Fieldbus Process Data Out 1 Bit 1	ON/OFF	R	
BV_15	FBDATAOUT1B2	Fieldbus Process Data Out 1 Bit 2	ON/OFF	R	
BV_16	FBDATAOUT1B3	Fieldbus Process Data Out 1 Bit 3	ON/OFF	R	
BV_17	FBDATAOUT1B4	Fieldbus Process Data Out 1 Bit 4	ON/OFF	R	





Instance ID	Object Name	Description	Active/Inactive Text	PV Access	Menu
BV_18	FBDATAOUT1B5	Fieldbus Process Data Out 1 Bit 5	ON/OFF	R	
BV_19	FBDATAOUT1B6	Fieldbus Process Data Out 1 Bit 6	ON/OFF	R	
BV_20	FBDATAOUT1B7	Fieldbus Process Data Out 1 Bit 7	ON/OFF	R	
BV_21	FBCNTRLBIT10	Fieldbus Control Word Bit 10	ON/OFF	C	
BV_22	FBCNTRLBIT11	Fieldbus Control Word Bit 11	ON/OFF	C	
BV_23	FBCNTRLBIT12	Fieldbus Control Word Bit 12	ON/OFF	C	
BV_24	FBCNTRLBIT13	Fieldbus Control Word Bit 13	ON/OFF	C	
BV_25	FBCNTRLBIT14	Fieldbus Control Word Bit 14	ON/OFF	C	
BV_26	FBCNTRLBIT15	Fieldbus Control Word Bit 15	ON/OFF	C	
BV_27	COAST2STOP	Command to issue a Coast to Stop	YES/READY	W	
BV_28	RAMP2STOP	Command to issue a Ramp to Stop	YES/READY	W	
BV_29	QUICK STOP	Command to issue a Quick Stop	YES/READY	W	
BV_30	FB CONTROL	Activates Fieldbus Control.	ON/OFF	C	
BV_31	FB REFERENCE	Activates Fieldbus Reference.	ON/OFF	C	
BV_32	INTERLOCK 1	Run Interlock 1	ON/OFF	R	P3.5.1.12
BV_33	INTERLOCK 2	Run Interlock 2	ON/OFF	R	P3.5.1.13
BV_34	ENERGY OPT	Energy Optimization	ON/OFF	R	P3.1.2.18
BV_35	AUTO RESET	Auto Reset	ON/OFF	R	P3.10.1
BV_36	FIREMODESTAT	Fire Mode Active	ACTIVE/INACTV	R	
BV_37	BYP ACTIVE		ACTIVE/INACTV	R	
BV_38	BYP RUNNING		YES/NO	R	
BV_39	REM SAFETY 1		FAULT/NOFLT	R	
BV_40	REM SAFETY 2		FAULT/NOFLT	R	
BV_41	REM SAFETY 3		FAULT/NOFLT	R	
BV_42	REM SAFETY 4		FAULT/NOFLT	R	
BV_43	REM SAFETY 5		FAULT/NOFLT	R	
BV_44	REM SAFETY 6		FAULT/NOFLT	R	
BV_45	REM SAFETY 7		FAULT/NOFLT	R	
BV_46	REM SAFETY 8		FAULT/NOFLT	R	

BACnet MS/TP Protocol Quick Setup

For monitoring objects through the BACnet MS/TP protocol, complete the following steps:

1. Select: **Main Menu > I/O and Hardware (M5) > RS-485 (M5.8) > Common Settings (M5.8.1) > Protocol (p5.8.1.1) > Edit.**

2. Select **BACnet MSTP** from the list and press the  button.

3. Select: **Main Menu > I/O and Hardware (M5) > RS-485 (M5.8) > BACnet MSTP (M5.8.3) > Parameters (M5.8.3.1) > Baud Rate (P5.8.3.1.1) > Edit.**
4. Enter the desired baud rate and press the  button.
5. Select: **Main Menu > I/O and Hardware (M5) > RS-485 (M5.8) > BACnet MSTP (M5.8.3) > Parameters (M5.8.3.1) > MAC Address (P5.8.3.1.2) > Edit.**
6. Enter the desired network device address and press the  button.
7. Select: **Main Menu > I/O and Hardware (M5) > RS-485 (M5.8) > BACnet MSTP (M5.8.3) > Parameters (M5.8.3.1) > Instance Number (P5.8.3.1.3) > Edit.**
8. Enter the desired instance number and press the  button. (Used when a BACnet MS/TP to BACnet IP router is on the network.)
9. Select: **Main Menu > I/O and Hardware (M5) > RS-485 (M5.8) > BACnet MSTP (M5.8.3) > Parameters (M5.8.3.1) > Comm. Timeout (P5.8.3.1.5) > Edit.**
10. Enter the desired time for drive to monitor for a communications loss and press the  button. A value of **0** disables this monitoring.

For commanding Start/Stop and Speed Reference using the BACnet MS/TP protocol, complete the following steps:

1. Complete all settings required for Monitoring as listed above.
2. Set **Ctrl. Place Auto** (P3.2.1) to a value of **FieldbusCTRL**.

For commanding Start/Stop through the BACnet MS/TP protocol and Speed Reference through an Analog Input, complete the following changes:

1. Complete all settings required for Monitoring as listed above.
2. Set **Ctrl. Place Auto** (P3.2.1) to a value of **FieldbusCTRL**.
3. Set **FieldbusCtrl Ref** (P3.3.9) to a value of **AI1** or **AI2** (depending upon which AI is in use).

For commanding Start/Stop through a Digital Input and Speed Reference through the BACnet MS/TP protocol, complete the following steps:

1. Complete all settings required for Monitoring as listed above.
2. Set **Ctrl. Place Auto** (P3.2.1) to a value of **I/O Control**.
3. Set **I/O A Ctrl Ref** (P3.3.3) to a value of **Fieldbus**.

P1 FLN (M5.8.3)

The Siemens P1 FLN fieldbus communications protocol is used by Siemens and others to connect terminal unit controllers to supervisory controllers. It is open to any manufacturer and widely used in the HVAC controls industry.

The physical characteristics of the P1 FLN bus is an RS-485 three-wire, with a maximum of 96 devices over a 4,000 foot (1219 m) distance, running at 4800 bps. The RS-485 interface is a half-duplex system. The transfer cable is supported as a Shielded Twisted Pair, type Belden 98410 or similar. However, on variable speed drives, the third wire (shield) is not terminated to the drive itself.

Logically, the P1 FLN is a master-slave protocol, with the supervisory controller being the master. Device points are partitioned into common HVAC control types, such as analog input, analog output, digital input, and digital output. P1 FLN messaging supports the reading, writing and overriding of these points.

The P1 FLN fieldbus protocol supports the following point types:

- Logical Digital Input (LDI) – a two-state input for reading status.
- Logical Digital Output (LDO) – a two-state output for commanding.
- Logical Analog Input (LAI) – a floating or multi-state input for status.
- Logical Analog Output (LAO) – a floating or multi-state output for commanding.

Each point type supports Change of Value (COV) reporting based on the point's present value, priority, and status (failed or normal). The output points are typically commandable from the P1 master panel where the input points are for monitoring purposes only.

If **Protocol** (5.8.1.1) is set to a value of **P1**, then configuration and status parameters related to the P1 fieldbus protocol are made available.

Parameters (M5.8.3.1)

The following configuration parameters are available for the P1 fieldbus protocol:

Table 103: P1 FLN Parameters.

Menu	Parameter	ID	Unit	Min	Max	Default	Description
P5.8.3.1.1	Slave Address	2534		0	127	99	Defines the unique slave address to be used by the drive on the P1 network. Broadcast messages are sent to device number 99 and all devices on the network respond to this address; therefore, address 99 is a reserved address and cannot be used on any device on the network.
P5.8.3.1.2	Baud Rate	2535	bps	4800	9600	4800	Defines the communications speed on the network which must match all devices on the network. Possible settings are: 1 = 4800 2 = 9600
P5.8.3.1.3	Communications Timeout	2536	s	0	65535	30	Defines the amount of time in which a packet is not received from the master before a communications timeout is faulted/alarmed. A setting of 0 means that no fault is generated.

Monitoring (M5.8.3.2)

The following monitoring values are available for the P1 fieldbus protocol:

Table 104: P1 FLN Monitoring.

Menu	Parameter	ID	Min	Max	Description
M5.8.3.2.1	Fieldbus Protocol Status	2537	Initializing	Faulted	Displays the current protocol status as follows: 0 = Initializing – Protocol is starting up. 1 = Stopped – Protocol is timed out or not in use. 2 = Operational – Protocol is running normally. 3 = Faulted – Major fault in protocol, requires restarting. If fault remains, contact Technical Support.

P1 FLN Point Map

The following is the P1 FLN point map for Application 2770 as used in the Siemens APOGEE Network:

Table 105: P1 FLN Point Map.

Point Number	Point Type	Subpoint Name	Factory Default	Engr. Units	Slope	Intercept	On Text	Off Text	Drive Menu
1	LAO	CTRL ADDRESS	99		1	0			
2	LAO	APPLICATION	2770		1	0			
3	LDI	AT SETPOINT	OFF				ON	OFF	
4	LAI	CURRENT	0	A	0.1	0			M2.2.4
5	LAI	DC BUS VOLT	0	V	0.1	0			M2.2.10
6	LDI	DRIVE READY	READY				READY	NOT READY	M2.2.17 Bit 1
7	LAI	DRIVE TEMP	0	°F	0.18	-58			M2.2.11
8	LAI	FREQ OUTPUT	0	HZ	0.1	-320			M2.2.1
9	LAI	MOTOR TEMP	0	%	0.1	0			M2.2.12
10	LAI	PCT OUTPUT	0	%	0.01	0			M2.8.12
11	LAI	POWER	0	%	0.1	0			M2.2.7
12	LAI	SPEED	0	RPM	1	0			M2.2.3
13	LAI	TORQUE	0	%	0.1	0			M2.2.5
14	LAI	VOLTAGE	0	V	0.1	0			M2.2.9
15	LAI	FIREMODESTAT	0		1	0			P3.16.7
16	LAI	DRIVE KWH	0	KWH	0.1	0			P4.4.1
17	LAI	DRIVE MWH	0	MWH	0.1	0			P4.4.1
18	LAI	RUN TIME	0	HRS	10	0			P4.4.7
20	LAO	OVRD TIME	1	HRS	1	0			
21	LDO	RUN ENABLE	STOP				ENABLE	STOP	P3.5.1.11
22	LDO	CMD FWD.REV	FWD				REV	FWD	
23	LDI	FWD.REV	FWD				REV	FWD	
24	LDO	CMD RUN.STOP	STOP				RUN	STOP	
25	LDI	RUN.STOP	STOP				RUN	STOP	
26	LDO	HAND AUTO	AUTO				HAND	AUTO	P3.2.2
27	LAO	INPUT REF A	0	PCT	0.01	0			
28	LAI	ACT FREQ REF	0	HZ	0.1	-320			M2.2.2
29	LDO	DAY.NGT	DAY				NIGHT	DAY	
30	LAI	ANALOG IN 1	0.00	PCT	0.01	0			P5.1.8
31	LAI	ANALOG IN 2	0.00	PCT	0.01	0			P5.1.10
32	LAI	ANALOG OUT 1	0.00	PCT	0.01	0			P5.1.12
33	LDI	DIGITAL IN 1	OFF				ON	OFF	P5.1.1
34	LDI	DIGITAL IN 2	OFF				ON	OFF	P5.1.2
35	LDI	DIGITAL IN 3	OFF				ON	OFF	P5.1.3

Point Number	Point Type	Subpoint Name	Factory Default	Engr. Units	Slope	Intercept	On Text	Off Text	Drive Menu
36	LDI	DIGITAL IN 4	OFF				ON	OFF	P5.1.4
37	LDI	DIGITAL IN 5	OFF				ON	OFF	P5.1.5
38	LDI	DIGITAL IN 6	OFF				ON	OFF	P5.1.6
39	LDO	RELAY OUT 1	OFF				ON	OFF	P5.1.13
40	LDO	RELAY OUT 2	OFF				ON	OFF	P5.1.14
41	LDO	RELAY OUT 3	OFF				ON	OFF	P5.1.15
42	LAO	FBDATA IN 1	0		1	0		P	
43	LAO	FBDATA IN 2	0		1	0			
44	LAO	FBDATA IN 3	0		1	0			
45	LAO	FBDATA IN 4	0		1	0			
46	LAO	FBDATA IN 5	0		1	0			
47	LAO	FBDATA IN 6	0		1	0			
48	LAO	FBDATA IN 7	0		1	0			
49	LAO	FBDATA IN 8	0		1	0			
50	LAI	FBDATA OUT 1	0		1	0			P3.6.1
51	LAI	FBDATA OUT 2	0		1	0			P3.6.2
52	LAI	FBDATA OUT 3	0		1	0			P3.6.3
53	LAI	FBDATA OUT 4	0		1	0			P3.6.4
54	LAI	FBDATA OUT 5	0		1	0			P3.6.5
55	LAI	FBDATA OUT 6	0		1	0			P3.6.6
56	LAI	FBDATA OUT 7	0		1	0			P3.6.7
57	LAI	FBDATA OUT 8	0		1	0			P3.6.8
58	LAO	PID1 GAIN	1000.00	PCT	0.1	0			P3.12.1.1
59	LAO	PID1 I TIME	10	SEC	0.1	0			P3.12.1.2
60	LAO	PID1 D TIME	0	SEC	0.1	0			P3.12.1.3
61	LAI	PID1 STATUS	0		1	0			M2.4.5
62	LAI	PID1 STPT	0		1	0			M2.4.1
63	LAI	PID1 FDBK	0		1	0			M2.4.2
64	LAI	PID1 OUTPUT	0	PCT	0.1	0			M2.4.4
65	LAO	PID 2 GAIN	1000.00	PCT	0.1	0			P3.13.1.3
66	LAO	PID2 I TIME	10.00	SEC	0.1	0			P3.13.1.4
67	LAO	PID2 D TIME	0	SEC	0.1	0			P3.13.1.5
68	LAI	PID2 STATUS	0		1	0			M2.5.5
69	LAI	PID2 STPT	0		1	0			M2.5.1
70	LAI	PID2 FDBK	0		1	0			M2.5.2
71	LAI	PID2 OUTPUT	0	PCT	0.1	0			M2.5.4
72	LAO	ANYPARM	0		1	0			

Point Number	Point Type	Subpoint Name	Factory Default	Engr. Units	Slope	Intercept	On Text	Off Text	Drive Menu
73	LAO	ANYVALUE	0		1	0			
74	LAI	ID VERSION	0		1	0			M4.8.6
75	LAI	AP VERSION	0		1	0			M4.8.7
76	LAO	ACCEL TIME	0	SEC	0.1	0.1			P3.4.2
77	LAO	DECEL TIME	0	SEC	0.1	0.1			P3.4.3
78	LDI	AUTORESET	OFF				ON	OFF	P3.10.1
79	LAI	CURRENT LMT	0	AMPS	0.1	0			P3.1.1.7
80	LDI	ENERGY OPT	OFF				ON	OFF	P3.1.2.18
81	LDI	INTERLOC1	OFF				ON	OFF	P3.5.1.12
82	LDI	INTERLOC2	OFF				ON	OFF	P3.5.1.13
83	LAI	MAX FREQ REF	500	HZ	0.1	0			P3.3.2
84	LAI	MIN FREQ REF	0	HZ	0.1	0			P3.3.1
85	LAI	MOTOR COSPHI			0.01	0.3			P3.1.1.5
86	LAI	MOTOR N CURR		AMPS	0.1	0			P3.1.1.4
87	LAI	MOTOR N PWR		HP	0.134	0			P3.1.1.6
88	LAI	MOTOR N SPD		RPM	1	24			P3.1.1.3
89	LAI	MOTOR N VOLT		VOLTS	1	0			P3.1.1.1
90	LAI	MOTOR N FREQ		HZ	0.01	8			P3.1.1.2
91	LDI	FAULT ACTIVE	NO				Yes	No	
92	LAI	FAULT ID	0		1	0			M2.2.18
93	LDO	RESET FAULT			1	0	RESET	NORMAL	
94	LAI	BYP ENABLE			1	0			P3.17.4
95	LAI	BYP SAFESTAT	0		1	0			M2.2.28
96	LDI	BYP ACTIVE	OFF				ON	OFF	
97	LDI	BYP RUNNING	OFF				ON	OFF	
98	LAI	BYP RUN TIME	0	HRS	1	0			M2.2.29
99	LAO	ERROR STATUS	0		1	0			

P1 Control Information

To monitor objects through P1 FLN, complete the following steps:

1. Set **Protocol** (P5.8.1.1) to a value of **P1**.
2. Set **Slave Address** (P5.8.3.1.1) to the desired P1 FLN node number.



NOTE:

Valid values are 0 through 127. Exception is 99; this is a broadcast address and is reserved. Do not assign an address of 99 to any device on the P1 FLN.

3. Set **Baud Rate** (P5.8.3.1.2) to the desired P1 FLN baud rate.

To command the Start/Stop and Speed Reference through P1 FLN, complete the following steps:

1. Complete all settings required for Monitoring as listed above.
2. Set **Control Place Auto** (P1.15 or P3.2.1) to a value of **FieldbusCTRL**.

To command Start/Stop through the P1 protocol, and Speed Reference through an Analog Input, complete the following steps:

1. Complete all settings required for Monitoring as listed above.
2. Set **Ctrl. Place Auto** (P3.2.1) to a value of **FieldbusCTRL**.
3. Set **FieldbusCtrl Ref** (P3.3.9) to a value of **AI1** or **AI2** (depending upon which AI is in use).

To command Start/Stop through a Digital Input, and Speed Reference through the P1 protocol, complete the following steps:

1. Complete all settings required for Monitoring as listed above.
2. Set **Ctrl. Place Auto** (P3.2.1) to a value of **I/O Control**.
3. Set **I/O A Ctrl Ref** (P3.3.3) to a value of **Fieldbus**.

Modbus RTU (M5.8.3)

Modbus RS-485 Parameters and Monitoring Values

Table 106: Parameters Related with Modbus Used through RTU.

Structure	Parameter	Unit	Min	Max	Default	ID	Description
Parameters							
P5.8.3.1.1	Slave Address		1	247	1	2320	Defines the Modbus RTU unique device address.
P5.8.3.1.2	Baud Rate	bps	300	230400	6	2378	Defines the communication speed of the Modbus RTU network. 1 = 300 2 = 600 3 = 1200 4 = 2400 5 = 4800 6 = 9600 7 = 19200 8 = 38400 9 = 57600 10 = 76800 11 = 115200 12 = 230400
P5.8.3.1.3	Parity Type		None	Even	None	2379	Defines the parity type of the Modbus RTU network: 0 = None 1 = Odd 2 = Even
P5.8.3.1.4	Stopbits		1 Sb	2 Sb	2 Sb	2380	Defines the stop bits of the Modbus RTU network: 1 = 1 Stop bit 2 = 1.5 Stop bits 3 = 2 Stop bits

Structure	Parameter	Unit	Min	Max	Default	ID	Description
P5.8.3.1.5	Comm. Timeout	s	0	65535	10	2321	Defines the time the device has to receive a token before indication of an error. 0 = Not used
P5.8.3.1.6	Operate Mode		Slave	Master	Slave	2374	Defines the operation mode on the Modbus RTU network: 0 = Slave 1 = Master
Monitoring							
M5.8.3.2.1	FB Protocol Status		Initializing	Faulted		2381	Displays the fieldbus protocol status as follows: 0 = Initializing (Protocol is starting) 1 = Stopped (Protocol is stopped) 2 = Operational (Protocol is communicating) 3 = Faulted (see <i>Last Fault (M5.8.3.2.4)</i> for detail) 4 = Inactive (No communications has occurred)
M5.8.3.2.2	Comm Status		0	99.999	0.0	2382	Displays the fieldbus protocol status as follows: 0 = Initializing (Protocol is starting) 1 = Stopped (Protocol is stopped) 2 = Operational (Protocol is communicating) 3 = Faulted (see <i>Last Fault (M5.8.3.2.4)</i> for detail) 4 = Inactive (No communications has occurred)
M5.8.3.2.3	Illegal Functions					2383	Format = <i>xx.yyy</i> where <i>xx</i> indicates bad frames and <i>yyy</i> indicates good messages
M5.8.3.2.4	Illegal data addr					2384	Displays the function code received that refers to an unallowed action for the server (slave).
M5.8.3.2.5	Illegal data values					2385	Displays the data address received that refers to an unallowed action for the server (slave).
M5.8.3.2.6	Slave device busy					2386	Displays the value received that refers to an unallowed action for the server (slave).
M5.8.3.2.7	Memory parity error					2387	Displays if the server (slave) is engaged in processing a long duration program command. The client (master) should retransmit the message later when the server (slave) is free.

Structure	Parameter	Unit	Min	Max	Default	ID	Description
M5.8.3.2.8	Slave Dev. Failure					2388	Displays if the server (slave) has detected a parity error in the memory when reading a record.
M5.8.3.2.9	Last Fault Response					2389	Displays the last fault response as fault code as follows: 0 = None (No fault detected since last power-up) 1 = Connection Timeout (time defined in Comm. Timeout (M5.8.3.1.5) has expired and token has not be received)
M5.8.3.2.10	Control Word					2390	Displays the control word received from the fieldbus. Based on 32 bits as described below: B0 = Start/Stop (0 = Stop; 1 = Start) B1 = Direction (0 = Forward; 1 = Reverse) B2 = Fault Reset (0 = No action; 1 = Reset faults) B3 - B31 = Not used
M5.8.3.2.11	Status Word					2391	Displays the status word sent to the fieldbus. Based on 32 bits as described below: B0 = Ready (0 = Not Ready; 1 = Ready) B1 = Run (0 = Stopped; 1 = Running) B2 = Direction (0 = Forward; 1 = Reverse) B3 = Fault (0 = No faulted; 1 = Faulted) B4 = Alarm (0 = No alarm; 1 = Alarm) B5 = At Reference (0 = False; 1 = True) B6 = Zero Speed (0 = False; 1 = True)

Modbus RTU Parameters

Slave address (P5.8.3.1.1)

Each slave must have a unique address (from 1 through 247) so that it can be addressed independently from other nodes.

Baud rate (P5.8.3.1.2)

Select the communication speed for the network. The default value is 9600 baud.

Parity type (P5.8.3.1.3)

You can select the parity type for the network.

Table 107: Parity Type.

Parity Type	Stopbits
Even	1
Odd	1
None	2

Communication Time-out (P5.8.3.1.5)

The Modbus board initiates a communication error for a time defined with this parameter. **0** means that no fault is generated.

Modbus RTU Monitoring Values

Fieldbus Protocol Status (P5.8.3.2.1)

Field Protocol Status indicates the status of the protocol.

Table 108: FB Protocol Statuses.

INITIALIZING	Protocol is starting up.
STOPPED	Protocol is timed out, or not used.
OPERATIONAL	Protocol is running.
FAULTED	Major fault in protocol, requires restarting. If fault persists, contact Technical Support.

Communication Status (P5.8.3.2.2)

The Communication Status shows how many errors and how many good messages the variable frequency drive has received. The Communication status includes a common error counter that counts CRC and parity errors and a counter for good messages.

Only messages to the current slave in use are counted in the good messages.

This parameter displays as **xx.yyy** where **xx** indicates **bad frames** and **yyy** indicates **good messages**.

For example, 01.002 would represent one bad frame and two good messages.

Illegal functions (P5.8.3.2.3)

The function code received in the query refers to an invalid action for the server (or slave).

Illegal data addresses (P5.8.3.2.4)

The data address received in the query refers to an invalid address for the server (or slave).

Illegal data values (P5.8.3.2.5)

A value **contained** in the query data field refers to an invalid value for server (or slave).

Slave device busy (P5.8.3.2.6)

The server (or slave) is engaged in processing a long-duration program command. The client (or master) should retransmit the message later when the server (or slave) is free.

Memory parity error (P5.8.3.2.7)

The server (or slave) attempted to read record file but detected a parity error in the memory.

Slave device failure (P5.8.3.2.8)

An unrecoverable error occurred while the server (or slave) was attempting to perform the requested action.

Last fault response (P5.8.3.2.9)

Displays the last fault response as **Fault code**.

Control word (P5.8.3.2.10)

Displays the **Control Word** received from the bus.

Word status (P5.8.3.2.11)

Displays the current **Status Word** that is sent to the bus.

Communications

Features of the Modbus-Siemens interface:

- Direct control of the Siemens drive (for example, Run, Stop, Direction, Speed reference, Fault reset)
- Full access to all Siemens parameters
- Monitor the Siemens status (Output frequency, Output current, Fault code)

Data addresses in Modbus messages

All data addresses in Modbus messages are referenced to zero. The first occurrence of a data item is addressed as item number zero. For example:

- The coil known as **Coil 1** in a programmable controller is addressed as **Coil 0000** in the data address field of a Modbus message.
- Coil 127 decimal is addressed as **Coil 007E hex** (126 decimal).
- Holding register 40001 is addressed as register 0000 in the data address field of the message. The function code field already specifies a 'holding register' operation. Therefore the **4XXXX** reference is implicit.
- Holding register 40108 is addressed as register 006B hex (107 decimal).

Modbus Memory Map

The Siemens variables and fault codes as well as the parameters can be read and written from Modbus. The parameter addresses are determined in the application. Every parameter and actual value has been given an ID number in the application. The ID numbering of the parameter as well as the parameter ranges and steps can be found in the operator's manual in question. The parameter value shall be given without decimals. If several parameters/actual values are read with one message, the addresses of the parameters/actual values must be consecutive.

Table 109: Supported Modbus Functions.

Function Code	Modbus Function Name	TCP/RTU	Access Type	Address Range (hex)
1 (0X01)	Read coils	TCP only	Discrete	00000 - 0FFFF
2 (0X02)	Read Discrete Inputs	TCP only	Discrete	10000 - 1FFFF
3 (0X03)	Read Holding Registers	TCP&RTU	16bit	40000 - 4FFFF
4 (0X04)	Read Input Registers	TCP&RTU	16bit	30000 - 3FFFF
5 (0X05)	Write Single Coils	TCP only	Discrete	00000 - 0FFFF

Function Code	Modbus Function Name	TCP/RTU	Access Type	Address Range (hex)
6 (0X06)	Write Single Register	TCP&RTU	16bit	40000 - 4FFFF
15 (0X0F)	Write Multiple Coils	TCP only	Discrete	00000 - 0FFFF
16 (0X10)	Write Multiple Registers	TCP&RTU	16bit	40000 - 4FFFF
23 (0X17)	Read/Write Multiple Registers	TCP&RTU	16bit	40000 - 4FFFF

**NOTE:**

Broadcasting is not supported in TCP. Broadcast is supported with function codes 06 and 16 in RTU.

Modbus Data Mapping

Coil registers

Coil registers contain binary data (Read/Write). For more information, see *Control word bits* in this chapter.

Table 110: Defined Modbus Coil Registers.

Address	Function	Purpose
0001	RUN/STOP	Control Word, bit 0.
0002	Direction	Control Word, bit 1.
0003	Fault reset	Control Word, bit 2.

Discrete inputs

Input discrete registers contain binary data (Read). For more information, see *Status word bits* in this chapter.

Table 111: Defined Modbus Discrete Inputs.

Address	Function	Purpose
10001	Ready	Status Word, bit 0.
10002	Run	Status Word, bit 1.
10003	Direction	Status Word, bit 2.
10004	Fault	Status Word, bit 3.
10005	Alarm	Status Word, bit 4.
10006	At reference	Status Word, bit 5.
10007	Zero speed	Status Word, bit 6.
10008	Flux ready	Status Word, bit 7.

Holding registers and input registers

All values can be read with function codes 3 and 4 (all registers are 3X and 4X reference). The Modbus registers are mapped to the Siemens BT300 Drive as follows:

Table 112: Defined Modbus Input and Holding Registers.

Register number	Purpose	Access type	See the Table...
0001 - 2000	Siemens Application IDs	16-bit	Parameter IDs [→ 149]
2001 - 2050	FBProcessDataIN	16-bit	Fieldbus Process Data IN [→ 149]
2051 - 2099	FBProcessDataIN	32-bit	Fieldbus Process Data IN [→ 149]
2101 - 2150	FBProcessDataOUT	16-bit	Fieldbus Process Data Out [→ 150]
2151 - 2199	FBProcessDataOUT	32-bit	Fieldbus Process Data Out [→ 150]
2200 - 10000	Siemens Application IDs	16-bit	Parameter IDs [→ 149]
10501 - 10530	IDMap	16-bit	ID Map Initialization [→ 152]
10601 - 10630	IDMap Read/Write	16-bit	Parameter Values in 16-bit IDMap Read/Write Registers [→ 152]
10701 - 10760	IDMap Read/Write	32-bit	Example of Parameter Values in 32-bit IDMap Read/Write Registers [→ 153]
20001 - 40000	Siemens Application IDs	32-bit	Parameter IDs [→ 149]
40001 - 40007	Operation day counter	16-bit	Operation Day Counter [→ 153]
40101 - 40107	Resettable operation day counter	16-bit	Resettable Operation Day Counter [→ 153]
40201 - 40203	Energy counter	16bit	Energy Counter [→ 154]
40301 - 40303	Resettable energy counter	16-bit	Resettable Energy Counter [→ 154]
40401 - 40430	Fault history	16-bit	Fault History [→ 154]

Application IDs

Application IDs are parameters that depend on the frequency converter's application. These parameters can be read and written by pointing the corresponding memory range directly or by using the so-called ID map. It is easiest to use a straight address if you want to read a single parameter value or parameters with consecutive ID numbers. It is possible to read 12 consecutive ID addresses.

Table 113: Modbus Parameter IDs.

Register number	Purpose	Application ID
0001-2000	Application parameters	1 through 2000
2200-10000	Application parameters	2200 through 10000

FB Process data IN

The process data fields are used to control the drive (for example, Run, Stop, Reference, Fault Reset) and to quickly read actual values (for example, Output frequency, Output current, Fault code). The fields are structured as follows:

Process Data Master → Slave (max 22 bytes)

Table 114: Fieldbus Process Data IN.

Address		Name	Range/Type
16-bit*	32-bit		
2001		2051 = High data 2052 = Low data	FB Control Word Binary coded
2002		-	Reserved Binary coded

Address		Name	Range/Type
16-bit*	32-bit		
2003		2053 = High data 2054 = Low data	FB Speed Reference 0 through 100.00% unit 0.01%
2004		2055 = High data 2056 = Low data	FB Process Data In 1 User-definable
2005		2057 = High data 2058 = Low data	FB Process Data In 2 User-definable
2006		2059 = High data 2060 = Low data	FB Process Data In 3 User-definable
2007		2061 = High data 2062 = Low data	FB Process Data In 4 User-definable
2008		2063 = High data 2064 = Low data	FB Process Data In 5 User-definable
2009		2065 = High data 2066 = Low data	FB Process Data In 6 User-definable

*In the Siemens BT300 Drive, the Control Word and the Status Word are formed of 32 bits. Only the initial 16 bits can be read in the 16-bit area.

Control word bits

The Control word is composed of 32 bits. The bits are described in the following table. Unused bits must be set to zero.

Table 115: Control Word Bits.

Bit	Name	Value 1	Value 0	Description
B0	Start/Stop	Start request	Stop request	Start/Stop command to application.
B1	Direction	Reverse	Forward	Command to change rotational direction.
B2	Fault reset	Reset faults	No action	Command to reset fault.
B3-B31		Not used		

FB Process data OUT

Process Data Slave → Master (max 22 bytes)

Table 116: Fieldbus Process Data Out.

Address		Name	Range/Type
16-bit	32-bit		
2101		2151 = High data 2152 = Low data	FB Status Word Binary coded.
2102		-	Reserved Binary coded.
2103		2153 = High data 2154 = Low data	FB Actual Speed 0 through 100.00, unit 0.01%.
2104		2155 = High data 2156 = Low data	FB Process Data Out 1 User-definable.
2105		2157 = High data 2158 = Low data	FB Process Data Out 2 User-definable.

Address		Name	Range/Type
16-bit	32-bit		
2106		2159 = High data 2160 = Low data	FB Process Data Out 3 User-definable.
2107		2161 = High data 2162 = Low data	FB Process Data Out 4 User-definable.
2108		2163 = High data 2164 = Low data	FB Process Data Out 5 User-definable.
2109		2165 = High data 2166 = Low data	FB Process Data Out 6 User-definable.
2110		2167 = High data 2168 = Low data	FB Process Data Out 7 User-definable.
2111		2169 = High data 2170 = Low data	FB Process Data Out 8 User-definable.

Status Word bits

The Status word is composed of 32 bits. The bits are described in the following table.

Table 117: Status Word Bits B1-B28.

Bit	Name	Value 1	Value 0	Description
B0	Ready	Ready	Not ready	Indicates whether the drive is ready or not.
B1	Run	Running	Stop	Indicates whether the drive is running or stopped.
B2	Direction	Counterclockwise	Clockwise	Indicates the rotation direction of the motor.
B3	Fault	Faulted	Not faulted	Indicates if a fault is active.
B4	Alarm	Alarm	No alarm	Indicates if an alarm is active.
B5	AtReference	True	False	Reference frequency reached.
B6	ZeroSpeed	True	False	Motor running at zero speed.
B7	FluxReady	True	False	Motor is magnetized.
B8-B28	Not used			

Table 118: Status Word Bits B29-B31, Descriptions of Bit Connections.

B29 Control place	B30 Control place	B31 Control place	Description
0	0	1	Fieldbus
0	1	0	Keypad
0	1	1	PC tool
1	0	0	I/O terminals

The use of process data depends on the application. In a typical situation, the device is started and stopped with the ControlWord (CW) written by the Master and the Rotating speed is set with Reference (REF). With PD1 through PD8 the device can be given other reference values (for example, Torque reference).

With the StatusWord (SW) read by the Master, the status of the device can be seen. Actual Value (ACT) and PD1 through PD8 show the other actual values.

ID Map

Using the ID map, you can read consecutive memory blocks that contain parameters whose IDs are not in a consecutive order. The address range 10501 through 10530 is called *IDMap*, and includes an address map in which you can write your parameter IDs in any order. The address range 10601 through 10630 is called *IDMap Read/Write*, and includes values for parameters written in the ID map. As soon as one ID number has been written in the map cell 10501, the corresponding parameter value can be read and written in the address 10601, and so on.

Table 119: ID Map Initialization.

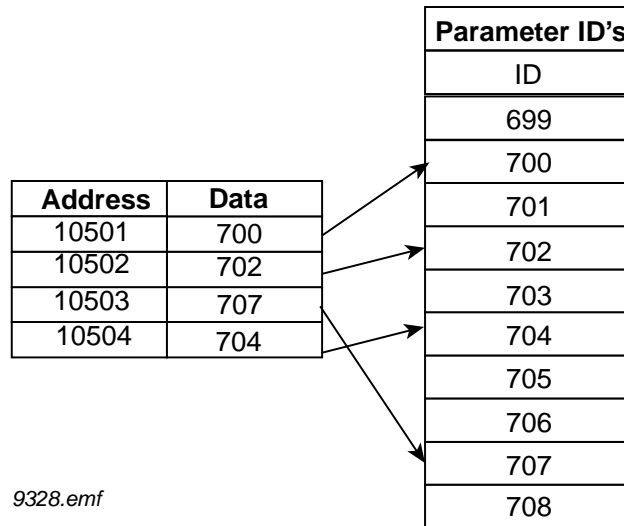

Once the IDMap address range has been initialized with any parameter ID number, the parameter value can be read and written in the IDMap Read/Write address range address IDMap address + 100.

Table 120: Parameter Values in 16-bit IDMap Read/Write Registers.

Address	Data
410601	Data included in parameter ID700
410602	Data included in parameter ID702
410603	Data included in parameter ID707
410604	Data included in parameter ID704

If the IDMap table has not been initialized, all fields show the index **0**. If it has been initialized, the parameter IDs included in it are stored in the flash memory of the OPT-CI board.

Example of 32-Bit IDMap

Table 121: Example of Parameter Values in 32-bit IDMap Read/Write Registers.

Address	Data
410701	Data High, parameter ID700
410702	Data Low, parameter ID700
410703	Data High, parameter ID702
410704	Data Low, parameter ID702

Operation Day Counter

Table 122: Operation Day Counter.

Address	Register	Purpose
40001	440001	Years
40002	440002	Days
40003	440003	Hours
40004	440004	Minutes
40005	440005	Seconds

Resettable Operation Day Counter

Reset the counter by writing **1** for Parameter ID2311.

Table 123: Resettable Operation Day Counter.

Address	Register	Purpose
40101	440101	Years
40102	440102	Days
40103	440103	Hours
40104	440104	Minutes
40105	440105	Seconds

Energy Counter

The last number of the **Format** field indicates the decimal point place in the **Energy** field. If the number is bigger than 0, move the decimal point to the left by the number indicated. For example, Energy = 1200, Format = 52. Unit = 1. Energy = 12.00 kWh.

Table 124: Energy Counter.

Address	Register	Purpose
40201	440201	Energy
40202	440202	Format
40203	440203	Unit 1 = kWh 2 = MWh 3 = GWh 4 = TWh

Resettable Energy Counter

Reset the counter by writing **1** for Parameter ID2312.

Table 125: Resettable Energy Counter.

Address	Register	Purpose
40301	440301	Energy
40302	440302	Format
40303	440303	Unit 1 = kWh 2 = MWh 3 = GWh 4 = TWh

Fault history

The fault history can be viewed by reading from address 40401 onward. The faults are listed in chronological order so that the latest fault is mentioned first and the oldest last. The fault history can contain 29 faults at the same time. The fault history contents are represented as follows.

Table 126: Fault History.

Address	Register	Purpose
40401	440401	
40402	440402	
40403	440403	
...	...	
40429	440429	

Example messages

Example 1

Write the process data 42001 through 42003 with command 16 (Preset Multiple Registers).

Command Master - Slave:

ADDRESS		01 hex Slave address 1 hex (= 1)
FUNCTION		10 hex Function 10 hex (= 16)
DATA	Starting address HI	07 hex Starting address 07D0 hex (= 2000)
	Starting address LO	D0 hex
	No. of registers HI	00 hex
	No. of registers LO	03 hex Number of registers 0003 hex (= 3)
	Byte count	06 hex Byte count 06 hex (= 6)
	Data HI	00 hex Data 1 = 0001 hex (= 1). Setting control word run bit to 1.
	Data LO	01 hex
	Data HI	00 hex Data 2 = 0000 hex (= 0).
	Data LO	00 hex
	Data HI	13 hex Data 3 = 1388 hex (= 5000), Speed Reference to 50.00%
	Data LO	88 hex
ERROR	CRC HI	C8 hex CRC field C8CB hex (= 51403)
CHECK	CRC LO	CB hex

Message frame:

01	10	07	D0	00	03	06	00	01	00	00	13	88	C8	CB
----	----	----	----	----	----	----	----	----	----	----	----	----	----	----

The reply to Preset Multiple Registers message is the echo of the 6 first bytes.

Answer Slave - Master:

ADDRESS		01 hex Slave address 1 hex (= 1)
FUNCTION		10 hex Function 10 hex (= 16)
DATA	Starting address HI	07 hex Starting address 07D0 hex (= 2000)
	Starting address LO	D0 hex
	No. of registers HI	00 hex Number of registers 0003 hex (= 3)
	No. of registers LO	03 hex
ERROR	CRC HI	80 hex CRC 8085 hex (= 32901)
CHECK	CRC LO	85 hex

Reply Frame:

01	10	07	D0	00	03	80	85
----	----	----	----	----	----	----	----

Example 2

Read the Process Data 42103 through 42104 with command 4 (Read Input Registers).

Command Master - Slave:

ADDRESS		01 hex Slave address 1 hex (= 1)
FUNCTION		04 hex Function 4 hex (= 4)
DATA	Starting address HI	08 hex
	Starting address LO	36 hex
	No. of registers HI	00 hex Number of registers 0002 hex (= 2)
	No. of registers LO	02 hex
ERROR	CRC HI	93 hex CRC field 93A5 hex (= 37797)
CHECK	CRC LO	A5 hex

Message frame:

01	04	08	36	00	02	93	A5
----	----	----	----	----	----	----	----

The reply to the Read Input Registers message contains the values of the read registers.

Answer Slave - Master:

ADDRESS		01 hex Slave address 1 hex (= 1)
FUNCTION		04 hex Function 4 hex (= 4)
DATA	Byte count	04 hex Byte count 4 hex (= 4)
	Data HI	13 hex Speed reference = 1388 hex (= 5000 = > 50.00%)
	Data LO	88 hex
	Data HI	09 hex Output Frequency = 09C4 hex (= 2500 = >25.00 Hz)
	Data LO	C4 hex
ERROR	CRC HI	78 hexCRC field 78E9 hex (= 30953)
CHECK	CRC LO	hex

Reply frame:

01	04	04	13	88	09	C4	78	E9
----	----	----	----	----	----	----	----	----

Example of an exception response

In an exception response, the Slave sets the *most-significant bit (MSB)* of the function code to **1**. The Slave returns an exception code in the data field.

Command Master - Slave:

ADDRESS		01 hex Slave address 1 hex (= 1)
FUNCTION		04 hex Function 4 hex (= 4)
DATA	Starting address HI	17 hex Starting address 1770 hex (= 6000)
	Starting address LO	70 hex

	No. of registers HI	00 hex Invalid number of registers 0005 hex (= 5)
	No. of registers LO	05 hex
ERROR	CRC HI	34 hex
CHECK	CRC LO	66 hex CRC field 3466 hex (= 13414)

Message frame:

01	04	17	70	00	05	34	66
----	----	----	----	----	----	----	----

Exception Response:

Answer Slave - Master:

ADDRESS	01 hex Slave address 1 hex (= 1)
FUNCTION	84 hex Most significant bit set to 1
ERROR CODE	04 hex Error code 04 => Slave Device Failure
ERROR CRC HI	42 hex CRC field 42C3 hex (= 17091)
CHECK CRC LO	C3 hex

Reply frame:

01	84	04	42	C3
----	----	----	----	----

Quick Setup

For monitoring of objects using ModBus RTU complete the following steps:

1. Select:
Main Menu > I/O and Hardware (M5) > RS-485 (M5.8) > Common settings (M5.8.1) > Protocol > Edit.
2. Select **ModBus RTU**.
3. Select:
Main Menu > I/O and Hardware (M5) > RS-485 (M5.8) > ModBus RTU (M5.8.3) > Parameters (M5.8.3.1) > Slave Address (M5.8.3.1.1) > Edit.
4. Enter desired **address**.
5. Select:
Main Menu > I/O and Hardware (M5) > RS-485 (M5.8) > ModBus RTU (M5.8.3) > Parameters (M5.8.3.1) > Baud Rate (M5.8.3.1.2) > Edit.
6. Select desired **baud rate**.
7. Select:
Main Menu > I/O and Hardware (M5) > RS-485 (M5.8) > ModBus RTU (M5.8.3) > Parameters (M5.8.3.1) > Parity Type (M5.8.3.1.3) > Edit.
8. Select desired **parity type**.

9. Select:
Main Menu > I/O and Hardware (M5) > RS-485 (M5.8) > ModBus RTU (M5.8.3) > Parameters (M5.8.3.1) > Stopbits (M5.8.3.1.4) > Edit.

10. Select desired **stop bits**.

For commanding of Run/Stop using ModBus RTU complete the following steps (in addition to the Monitoring steps above):

1. Select:
Main Menu > Quick Setup (M1) > Ctrl. Place Auto (M1.15) > Edit.
2. Select **FieldBusCTRL**.

For commanding of Speed Reference using ModBus RTU complete the following steps (in addition to the monitoring steps above):

1. Select:
Main Menu > Quick Setup (M1) > I/O A Ctrl Ref (M1.10) > Edit.
2. Select **Fieldbus**.

Ethernet (M.5.9)

Ethernet settings are used to define and configure the fieldbus protocol. The wiring is the same for all Ethernet protocol, as shown below.

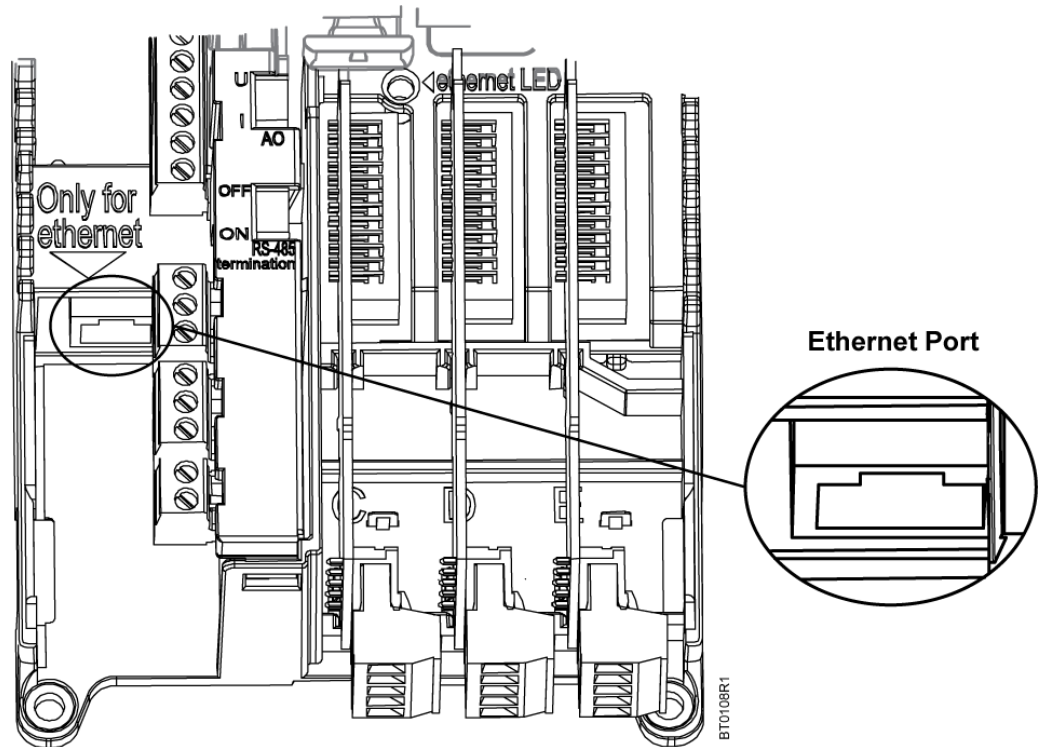

Figure 36: Ethernet Connection.

Common Settings (M5.9.1)

Table 127: Ethernet Common Settings (M5.9.1).

Structure	Parameter	Min	Max	Unit	Default	ID	Description
P5.9.1.1	IP Address Mode		DHCP with AutoIP	Fixed IP	DHCP with AutoIP	2482	Defines the IP addressing mode as follows: 0 = Fixed IP 1 = DHCP with AutoIP
P5.9.1.2	Fixed IP						See below.
P5.9.1.3	IP Address					2483	Displays the actual IP Address in use.
P5.9.1.4	Subnet Mask					2484	Displays the actual subnet mask in use.
P5.9.1.5	Default Gateway					2485	Displays the actual default gateway in use.
P5.9.1.6	MAC Address					2486	Displays the Ethernet card's MAC address.

Table 128: Fixed IP (M5.9.1.2)

Structure	Parameter	Min	Max	Unit	Default	ID	Description
P5.9.1.2.1	IP Address				192.168.0.10	2529	Defines the maximum number of clients (master) can access the server (slave) simultaneously.
P5.9.1.2.2	Subnet Mask				255.255.0.0	2530	Defines the Modbus TCP unique device address.
P5.9.1.2.3	Default Gateway				192.168.0.1	2531	Defines the time the device has to receive a token before indication of an error. 0 = Not used

Ethernet Common Settings

IP Address Mode (P5.9.1.1)

Selectable alternatives are **DHCP** (Dynamic Host Configuration Protocol) and **Fixed**.

DHCP protocol gives IP addresses to new devices connecting to local network. This address is valid for a certain period of time. If no DHCP server is found, an automatic random IP is given.

A fixed IP address is specified manually and does not change.

When the mode is changed from DHCP to Fixed, the addresses will read:

IP: 192.168.0.10

Subnet mask:255.255.0.0

Default gateway: 192.168.0.1

IP address (P5.9.1.3)

An **IP address** is a series of numbers (as above) specific to the device connected to the Internet.

Subnet Mask (P5.9.1.4)

The network mask marks all the bits of an IP address for the identification of the network and the subnetwork.

Default Gateway (P5.9.1.5)

The gateway address is the IP address of a network point that acts as an entrance to another network.

MAC address (P5.9.1.6)

The MAC address of the control board.

A MAC address (Media Access Control) is a unique address given to each network host. It is not editable.

Modbus TCP (M5.9.2)

For further information on the Modbus register list, see *Modbus RTU (M5.8.3)*.

Modbus TCP Parameters and Monitoring Values

Modbus TCP Settings

Table 129: Parameters Related to Modbus TCP.

Code	Parameter	Min	Max	Unit	Default	ID	Description
PARAMETERS (Common Settings)							
P5.9.2.1.1	Connection limit	0	3		2	2446	Number of allowed connections
P5.9.2.1.2	Unit identifier number	0	255		1	2447	See the <i>Modbus TCP Settings</i> section.
P5.9.2.1.3	Communication time-out	0	65535	s	0	2448	0 = Not used
MONITORING VALUES (Connection 1, Monitoring *							
M5.9.2.2.1.1	Fieldbus protocol status	1	3			2449	1 = Stopped 2 = Operational 3 = Faulted
M5.9.2.2.1.2	Communication status	0.0	99.999		0.0	2450	0-99 Number of messages with errors. 0-999 Number of messages without communication errors.
M5.9.2.2.1.3	Illegal functions	0				2451	See <i>Illegal functions (P5.9.2.2.1.3)</i> .
M5.9.2.2.1.4	Illegal data addresses	0				2452	See <i>Illegal data addresses (P5.9.2.2.1.4)</i> .
M5.9.2.2.1.5	Illegal data values	0				2453	See <i>Illegal data values (P5.9.2.2.1.5)</i> .
M5.9.2.2.1.6	Slave device busy	0				2454	See <i>Slave device busy (P5.9.2.2.1.6)</i> .
M5.9.2.2.1.7	Memory parity error	0				2455	See <i>Memory parity error (P5.9.2.2.1.7)</i> .
M5.9.2.2.1.8	Slave device failure	0				2456	See <i>Slave device failure (P5.9.2.2.1.8)</i> .
M5.9.2.2.1.9	Last fault response	0				2457	See <i>Last fault response (P5.9.2.2.1.9)</i> .
M5.9.2.2.1.10	Control word			hex		2458	See <i>Control Word Bits</i> .
M5.9.2.2.1.11	Status word			hex		2459	See <i>Status Word Bits</i> .
MONITORING VALUES (Connection 2, Monitoring)*							
P5.9.2.2.1.1	Fieldbus protocol status	1	3			2460	1 = Stopped 2 = Operational 3 = Faulted
P5.9.2.2.1.2	Communication status	0.0	99.999		0.0	2461	0-99 Number of messages with errors. 0-999 Number of messages without communication errors.
P5.9.2.2.1.3	Illegal functions	0				2462	See <i>Illegal functions (P5.9.2.2.1.3)</i> .
P5.9.2.2.1.4	Illegal data addresses	0				2463	See <i>Illegal data addresses (P5.9.2.2.1.4)</i> .

Code	Parameter	Min	Max	Unit	Default	ID	Description
P5.9.2.2.1.5	Illegal data values	0				2464	See <i>Illegal data values (P5.9.2.2.1.5)</i> .
P5.9.2.2.1.6	Slave device busy	0				2465	See <i>Slave device busy (P5.9.2.2.1.6)</i> .
P5.9.2.2.1.7	Memory parity error	0				2466	See <i>Memory parity error (P5.9.2.2.1.7)</i> .
P5.9.2.2.1.8	Slave device failure	0				2467	See <i>Slave device failure (P5.9.2.2.1.8)</i> .
P5.9.2.2.1.9	Last fault response	0				2468	See <i>Last fault response (P5.9.2.2.1.9)</i> .
P5.9.2.2.1.10	Control word			hex		2469	See <i>Control Word Bits</i> .
P5.9.2.2.1.11	Status word			hex		2470	See <i>Status Word Bits</i> .
MONITORING VALUES (Connection 3, Monitoring)*							
M5.9.2.2.1.1	Fieldbus protocol status	1	3			2471	1 = Stopped 2 = Operational 3 = Faulted
M5.9.2.2.1.2	Communication status	0.0	99.999		0.0	2472	0-99 Number of messages with errors. 0-999 Number of messages without communication errors.
M5.9.2.2.1.3	Illegal functions	0				2473	See <i>Illegal functions (P5.9.2.2.1.3)</i> .
M5.9.2.2.1.4	Illegal data addresses	0				2474	See <i>Illegal data addresses (P5.9.2.2.1.4)</i> .

*Only displays after a connection has been established.

Modbus TCP Settings

Common Settings

Connection limit (P5.9.2.1.1)

Defines how many clients can access the server simultaneously.

Unit identifier number (P5.9.2.1.2)

The Modbus **slave address** field usually used on Modbus Serial Line is replaced by a single byte **Unit Identifier**.

On TCP/IP, the Modbus server is addressed using its IP address; therefore, the Modbus Unit Identifier is not used.

Communication time out number (P5.9.2.1.3)

Modbus initiates a communication error if the Ethernet connection is lost. Communication time-out parameters define the minimum delay between packages received from the client. The timer is reset and started after each received package. This parameter can be used if the client is periodically polling the slaves.

Modbus TCP Monitoring Values

These values only display after a connection has been established.

Connection 1

Fieldbus protocol status (P5.9.2.2.1.1)

The **Fieldbus Protocol Status** provides the status of the protocol.

Table 130: FB Protocol Status.

INITIALIZING	Protocol is starting up.
STOPPED	Protocol is timed out or not used.
OPERATIONAL	Protocol is running.
FAULTED	Major fault in protocol, requires restarting. If fault remains contact your local Siemens Industry office or Technical Support.

Communication status (P5.9.2.2.1.2)

The **Communication status** shows how many error messages and how many good messages the frequency converter has received. The Communication status includes a common error counter that counts errors and a counter for good messages.

This parameter displays as **xx.yyy** where **xx** indicates **bad frames** and **yyy** indicates **good messages**. For example, 01.002 would represent one bad frame and two good messages.

Illegal functions (P5.9.2.2.1.3)

This value counts error situations. The function code received in the query refers to an invalid action for the server (or slave). This corresponds to Modbus fault code **01h**.

Illegal data addresses (P5.9.2.2.1.4)

This value counts error situations. The data address received in the query refers to an invalid address for the server (or slave). This corresponds to Modbus fault code **02h**.

Illegal data values (P5.9.2.2.1.5)

This value counts error situations. A value contained in the query data field refers to an invalid value for server (or slave). This corresponds to Modbus fault code **03h**.

Slave device busy (P5.9.2.2.1.6)

This value counts error situations. The server (or slave) is engaged in processing a long-duration program command. The client (or master) should retransmit the message later when the server (or slave) is free. This corresponds to Modbus fault code **06h**.

Memory parity error (P5.9.2.2.1.7)

This value counts error situations. The server (or slave) attempted to read record file but detected a parity error in the memory. This corresponds to Modbus fault code **08h**.

Slave device failure (P5.9.2.2.1.8)

This value counts error situations. An unrecoverable error occurred while the server (or slave) was attempting to perform the requested action. This corresponds to Modbus fault code **04h**.

Last fault response (P5.9.2.2.1.9)

Displays the last fault response as **Fault code**.

Control word (P5.9.2.2.1.10)

Displays the Control Word received from the bus.

Status word (P5.9.2.2.1.11)

Displays the current Status Word that is sent to the bus.

Connection 2

The monitoring values display the same pieces of information as for Connection 1 [→ 163], for the 2nd and 3rd connections.

Connection 3

The monitoring values display the same pieces of information as for Connection 1 [→ 163], for the 2nd and 3rd connections.

Quick Setup

For monitoring objects using ModBus TCP, complete the following steps:

	NOTICE The DHCP settings must be set properly. Otherwise, a Fixed IP address may have to be setup.
---	--

If using DHCP, complete the following steps:

1. Select:
Main Menu > I/O and Hardware (M5) > Ethernet (M5.9) > Common settings (M5.9.1) > IP Address Mode (M5.9.1.1).
2. Verify this is set to **DHCP with AutoIP**.
3. Select:
Main Menu > I/O and Hardware (M5) > Ethernet (M5.9) > Common settings (M5.9.1) > IP Address (M5.9.1.2).
4. Verify that a **valid IP Address** has been assigned.

If using a Fixed IP address, complete the following:

1. Select:
Main Menu > I/O and Hardware (M5) > Ethernet (M5.9) > Common settings (M5.9.1) > IP Address Mode (M5.9.1.1) > Edit.
2. Select **Fixed IP**.
3. Select:
Main Menu > I/O and Hardware (M5) > Ethernet (M5.9) > Common settings (M5.9.1) > IP Address (M5.9.1.2) > Edit.
4. Enter desired **IP address**.
5. Select:
Main Menu > I/O and Hardware (M5) > Ethernet (M5.9) > Common settings (M5.9.1) > Subnet Mask (M5.9.1.3) > Edit.

6. Enter the desired **subnet mask**.
7. Select:
Main Menu > I/O and Hardware (M5) > Ethernet (M5.9) > Common settings (M5.9.1) > Default Gateway (M5.9.1.4) > Edit.
8. Enter the desired **default gateway**.

For either DHCP or Fixed, the following steps must be completed:

1. Select:
Main Menu > I/O and Hardware (M5) > Ethernet (M5.9) > ModBusTCP (M5.9.2) > Common Settings (M5.9.2.1) > Connection Limit (M5.9.2.1.1) > Edit.
2. Select the desired connection limit.
3. Select:
Main Menu > I/O and Hardware (M5) > Ethernet (M5.9) > ModbusTCP (M5.9.2) > Common Settings (M5.9.2.1) > Slave Address (M5.9.2.1.2) > Edit.
4. Enter the desired address.

For commanding Run/Stop using BACnet/IP complete the following steps (in addition to the Monitoring steps above):

1. Select:
Main Menu > Quick Setup (M1) > Ctrl. Place Auto (M1.15) > Edit.
2. Select **FieldBusCTRL**

For commanding of Speed Reference using BACnet/IP complete the following steps (in addition to the monitoring steps above):

1. Select:
Main Menu > Quick Setup (M1) > I/O A Ctrl Ref (M1.10) > Edit.
2. Select **Fieldbus**.

BACnet IP (M5.9.3)

BACnet IP Parameters and Monitoring Values

Ethernet Common Settings (M5.9.1)

Table 131: Common Settings for BACnet/IP.

Code	Parameter	Min	Max	Unit	Default	ID	Description
P5.9.1.1	IP address mode						See <i>Ethernet common settings</i> .
P5.9.1.3	IP address						See <i>Ethernet common settings</i> .
P5.9.1.4	Subnet mask						See <i>Ethernet common settings</i> .
P5.9.1.5	Default gateway						See <i>Ethernet common settings</i> .
P5.9.1.6	MAC address						See <i>Ethernet common settings</i> .

BACnet IP Settings

Table 132: Parameters Related with BACnet Used Through Ethernet.

Code	Parameter	Min	Max	Unit	Default	ID	Description
P5.9.3.1.1	Instance number	0	4194304		0	2406	Device object's instance number 0 = Serial number
P5.9.3.1.2	Communication time-out	0	65535	m	0	2407	0 = Not used NOTE: This setting is in minutes.
P5.9.3.1.3	Protocol in use	0	1		0	2408	0 = Not used 1 = Used
P5.9.3.1.4	BBMD OP	0.0.0.1	255.255.255.255		192.168.0.1	2409	Network BBMD IP address.
P5.9.3.1.5	BBMD Port	1	65535		47808	2410	BBMD UDP Port number.
P5.9.3.1.6	Time to live	0	255		0	2411	

Table 133: Monitoring Values.

Code	Parameter	Min	Max	Unit	Default	ID	Description
M5.9.3.2.1	Fieldbus protocol status	1	3				1 = Stopped 2 = Operational 3 = Faulted
M5.9.3.2.2	Communication status	0.0	99.999		0.0		0-99 Number of messages with errors. 0-999 Number of messages without communication errors.
M5.9.3.2.3	Actual instance number	0	65535		Serial number		Shows actual Device Object's instance number.
M5.9.3.2.4	Control word			hex			See <i>IP monitoring values</i> .
M5.9.3.2.5	Status word			hex			See <i>IP monitoring values</i> .

BACnet IP Parameter Descriptions

Ethernet Common Settings

IP address mode (P5.9.1.1)

- Selectable alternatives are **DHCP** (Dynamic Host Configuration Protocol) and **Fixed**.
 - DHCP protocol gives IP addresses to new devices connecting to the local network. This address is valid for a certain period of time.
 - A Fixed IP address is specified manually and it does not change.
- When the mode is changed from **DHCP** to **Fixed**, the addresses will read:
 - IP:** 192.168.0.10
 - Subnet mask:** 0.0.0.0
 - Default gateway:** 0.0.0.0

IP address (P5.9.1.3)

An *IP address* is a series of numbers, such as **192.168.0.10**, which is specific to the device connected to the Internet.

Subnet mask (P5.9.1.4)

The network mask marks all the bits of an IP address for the identification of the network and the subnetwork.

Default gateway (P5.9.1.5)

Gateway address is the IP address of a network point that acts as an entrance to another network.

MAC address (P5.9.1.6)

- *MAC address* (Media Access Control) is a unique address given to each network host.
- The MAC address of the control board.

BACnet IP Settings

Instance number (P 5.9.3.1.1)

Similar to BACnet MS/TP device object instance number (see Instance Number (P5.9.3.1.4)).

Communication time-out (P5.9.3.1.2)

BACnet board initiates a communication error if the Ethernet connection is lost. Communication time-out parameters define the minimum delay between UDP packages received from the master.

The timer is reset and started after each received UDP package. This parameter can be used if the master is periodically polling the slaves.

Protocol in use (P5.9.3.1.3)

Use this parameter to enable and disable the BACnet/IP protocol.

- When the parameter value is set to **1**, the BACnet/IP protocol is enabled.
- When the parameter value is set to **0**, the BACnet/IP protocol is disabled.

IP Monitoring Values

Fieldbus protocol status (P5.9.3.2.1)

Fieldbus protocol status tells the status of the protocol.

Communication status (P5.9.3.2.2)

The Communication status displays how many error messages and how many good messages the variable frequency drive has received. The Communication status includes a common error counter that counts CRC and parity errors and a counter for good messages.

This parameter displays as **xx.yyy** where **xx** indicates **bad frames** and **yyy** indicates **good messages**.

For example, 01.002 would represent one bad frame and two good messages.

Actual instance number (P5.9.3.2.3)

The Device Object's actual instance number. This monitoring value is needed when value **0** is written to Parameter P5.9.3.1.1.

Control word (P5.9.3.2.3)

Displays the **Control word** received from the bus.

Status word (P5.9.3.2.4)

Displays the current **Status word** that is sent to the bus.

Quick Setup

For monitoring objects using BACnet IP, complete the following steps:

!	NOTICE
	The DHCP settings must be set properly. Otherwise, a Fixed IP address may have to be set up.

If using DHCP, complete the following steps:

1. **Select:**
Main Menu > I/O and Hardware (M5) > Ethernet (M5.9) > Common settings (M5.9.1) > IP Address Mode (M5.9.1.1).
2. Verify this is set to **DHCP with AutoIP**.
3. **Select:**
Main Menu > I/O and Hardware (M5) > Ethernet (M5.9) > Common settings (M5.9.1) > IP Address (M5.9.1.2).
4. Verify that a **valid IP Address** has been assigned.

If using a Fixed IP address, complete the following steps:

1. **Select:**
Main Menu > I/O and Hardware (M5) > Ethernet (M5.9) > Common settings (M5.9.1) > IP Address Mode (M5.9.1.1) > Edit.
2. Select **Fixed IP**.
3. **Select:**
Main Menu > I/O and Hardware (M5) > Ethernet (M5.9) > Common settings (M5.9.1) > IP Address (M5.9.1.2) > Edit.
4. Enter the desired **IP address**.
5. **Select:**
Main Menu > I/O and Hardware (M5) > Ethernet (M5.9) > Common settings (M5.9.1) > Subnet Mask (M5.9.1.3) > Edit.
6. Enter the desired **subnet mask**.
7. **Select:**
Main Menu > I/O and Hardware (M5) > Ethernet (M5.9) > Common settings (M5.9.1) > Default Gateway (M5.9.1.4) > Edit.
8. Enter the desired **default gateway**.

For either DHCP or Fixed, the following steps must be completed:

1. **Select:**
Main Menu > I/O and Hardware (M5) > Ethernet (M5.9) > BACnet IP (M5.9.3) > Settings (M5.9.3.1) > Instance Number (M5.9.3.1.1) > Edit.
2. Select desired **device instance number**.

3. Select:
Main Menu > I/O and Hardware (M5) > Ethernet (M5.9) > BACnet IP (M5.9.3) > Settings (M5.9.3.1) > Protocol in use (M5.9.3.1.3) > Edit.
4. Set to a value of 1.
5. Select:
Main Menu > I/O and Hardware (M5) > RS-485 (M5.9) > BACnetMSTP (M5.9.3) > Parameters (M5.9.3.1) > Instance Number (M5.9.3.1.4) > Edit.
6. Enter the desired **device instance number** between 0 and 4194303.

For commanding of Run/Stop using BACnet/IP complete the following steps (in addition to the Monitoring steps above):

1. Select:
Main Menu > Quick Setup (M1) > Ctrl. Place Auto (M1.15) > Edit.
2. Select **FieldBusCTRL**

For commanding Speed Reference using BACnet/IP complete the following steps (in addition to the monitoring steps above):

1. Select:
Main Menu > Quick Setup (M1) > I/O A Ctrl Ref (M1.10) > Edit.
2. Select **Fieldbus**.

User Settings (M6)

User settings (M6) are drive- and keypad-specific settings. This section contains the following information:

Table 134: User Settings.

Menu and Parameter Group	Description
Language Selection (P6.1)	Selection of the language the keypad is displayed in.
Parameter Backup (M6.5)	Backup and restore functions for the drive.
Parameter Compare (M6.6)	Parameter comparison to defaults, or backup files.
Drive Name (P6.7)	User-defined name for the drive.

User settings (M6) contain the following parameters:

Structure	Parameter	ID	Description
P.1	Language Selections	802	Selection of the language for the keypad use. This varies depending upon the language package installed.
P6.5	Parameter Backup		See <i>Parameter Backup (M6.5)</i> .
P6.6	Parameter Compare		See <i>Parameter Backup (M6.5)</i> .
P6.7	Drive Name	2528	User-defined name for the drive. Default value is the serial number of the drive.

Parameter Backup (M6.5)

The parameterization can be used to restore the drive to factory default values, stored in and restored from keypad, backup set 1 (in the drive), and backup set 2 (in the drive).

Table 135: Parameter Backup.

Structure	Parameter	ID	Description
P6.5.1	Restore Factory Default	831	Activation parameter for restoring parameters to the factory settings. NOTE: Does not reset: Time (P5.5.2), Date (P5.5.3), Year (P5.5.4), Daylight Saving (P5.5.5)
P6.5.2	Save to Keypad	2487	Initiates a copy of the active set of parameters to the keypad's storage location.
P6.5.3	Restore from Keypad	2488	Initiates a copy of the keypad's storage location to the active set of parameters.
P6.5.4	Save to Set 1	2489	Initiates a copy of the active set of parameters to the drives set 1 storage location.
P6.5.5	Restore from Set 1	2490	Initiates a copy of the drives set 1 storage location to the active set of parameters.
P6.5.6	Save to Set 2	2491	Initiates a copy of the active set of parameters to the drives set 2 storage location.
P6.5.7	Restore from Set 2	2492	Initiates a copy of the drives set 2 storage location to the active set of parameters.

Parameter Compare (M6.6)

The keypad can be used to compare the drive's active set of parameters to default values, stored sets on the drive, and the stored set on the keypad. See the *Parameter Backup (6.5)* section for details on how to back up and restore using these sets.

Table 136: Parameter Compare (M6.6).

Structure	Parameter	ID	Description
P6.6.1	Active Set-Set 1	2493	Initiates a compare of the drive's active parameter set to the saved set 1. All parameters that are different are displayed, with values.
P6.6.2	Active Set-Set 2	2494	Initiates a compare of the drive's active parameter set to the saved set 2. All parameters that are different are displayed, with values.
P6.6.3	Active Set-Defaults	2495	Initiates a compare of the drive's active parameter set to the default values. All parameters that are different are displayed, with values.
P6.6.4	Active Set-Keypad Se	2496	Initiates a compare of the drive's active parameter set to the keypad saved set. All parameters that are different are displayed, with values.

Favorites (M7)

Favorites are typically used to collect a set of commonly referred to sets of parameters or monitoring signals from any of the keypad menus. Items can be added to the **Favorites** folder by selecting the **Add To Favorites** option.

To remove an item from the **Favorites** menu, select the item in the **Favorites** menu, and then select the **Remove from Favorites** option.

User Levels (M8)

User level parameters are intended to restrict the visibility of parameters and prevent the unauthorized and inadvertent parameterization on the keypad.

To lock the keypad from unauthorized changes, complete the following steps:

1. Set **Access Code** (P8.2) to a value other than 0.

**NOTE:**

Store this access code in a safe place. If the code is lost, the only method to recover is to reload firmware and re-commission the drive.

2. Set **User Level** (P8.1) to a value of **Monitoring**.

When in the monitoring user level, only the Monitor (M2), Favorites (M7), and User Levels (M8) menu options are available through the keypad.

To switch back to Normal mode, complete the following steps:

1. Set **User Level** (P8.1) to a value of **Normal**.
2. When prompted for **Access Code** (P8.2), enter the value previously entered when locking the key-pad.

Table 137: User Level Settings.

Structure	Parameter	Unit	Min	Max	Default	ID	Description
P8.1	User Level		Normal	Monitoring	Normal	1194	Defines the user level mode of the keypad. 0 = Normal = All menus are available. 1 = Monitoring = Only the Monitor (M2), Favorites (M7), and User Levels (M8) menus are available.
P8.2	Access Code		0	99999	0	2362	Defines the access code to be used when switching User Level (P8.1).

Chapter 5 - Fault Tracing

When the drive control diagnostics detect an unusual operating condition, the drive initiates a visible notification on the keypad. The keypad displays the code, the name and a short description of the fault or alarm.

Notifications vary in consequence and required action. *Faults* make the drive stop and require a reset of the drive. *Alarms* inform of unusual operating conditions, but the drive will continue to run. *Infos* may require resetting but do not affect the drive's operation.

For some faults, you can program different responses in the application. See the parameter group Protections.

The fault can be reset with the **Reset** button on the control keypad or via the I/O terminal. The faults are stored in the **Fault history** menu which can be browsed. Fault codes are outlined in the following table.



NOTE:

For a fault condition, contact Technical Support.

Always write down all texts and codes on the keypad display and a description of the problem together with the Drive Info file.

Fault Displays

When a fault displays and the drive stops, examine the cause of the fault, perform the actions advised here and reset the fault as instructed below.

- Press the **Reset** button on the keypad for one second, or
- Select the **Diagnostics** Menu (M4), select **Reset Faults** (P4.2) and select **Reset Faults** parameter.

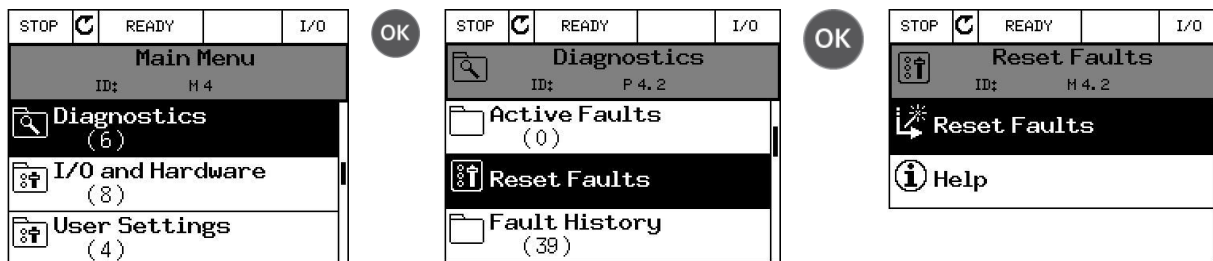

Fault history

In menu M4.3, Fault history, you find the maximum number of 40 occurred faults. On each fault in the memory, you will also find additional information. See the following figure.

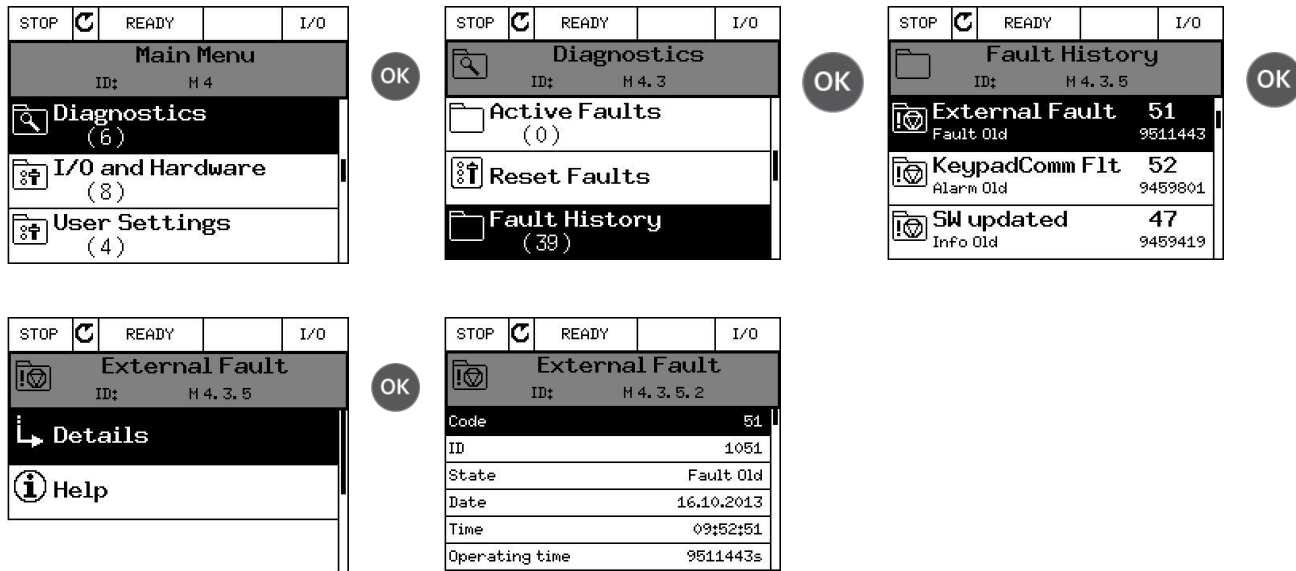

Fault Codes

Table 138: Fault Codes and Descriptions.

Fault Code	Fault ID	Fault Name	Possible Cause	Remedy
1	1	Over-current (hardware fault)	The drive has detected too high a current ($>4 \cdot I_{\mu}$) in the motor cable:	Check loading. Check motor. Check cables and connections. Make identification run. Check ramp times.
	2	Over-current (software fault)	<ul style="list-style-type: none"> ● sudden heavy load increase ● short circuit in motor cables ● unsuitable motor 	
2	10	Over-voltage (hardware fault)	The DC-link voltage has exceeded the limits defined.	Make deceleration time longer. Activate overvoltage controller. Check input voltage.
	11	Over-voltage (software fault)	<ul style="list-style-type: none"> ● too short a deceleration time ● high over-voltage spikes in supply ● Start/Stop sequence too fast 	
3	20	Earth fault (hardware fault)	Current measurement has detected that the sum of motor phase current is not zero.	Check motor cables and motor.
	21	Earth fault (software fault)	<ul style="list-style-type: none"> ● insulation failure in cables or motor 	
5	40	Charging switch	The charging switch is open, when the START command has been given. <ul style="list-style-type: none"> ● faulty operation ● component failure 	Reset the fault and restart. Should the fault re-occur, contact the distributor near to you.
7	60	Saturation	Various causes: <ul style="list-style-type: none"> ● Defective component ● Brake resistor short-circuit or overload 	Cannot be reset from keypad. Switch off power. DO NOT RECONNECT POWER! Contact the factory. If this fault appears simultaneously with F1, check motor cables and motor.

Fault Code	Fault ID	Fault Name	Possible Cause	Remedy
8	600	System fault	Communication between control board and power unit has failed.	Reset the fault and restart. Should the fault re-occur, contact your distributor.
	602		Watchdog has reset the CPU.	
	603		Voltage of auxiliary power in power unit is too low.	
	604		Phase fault: Voltage of an output phase does not follow the reference.	
	605		CPLD has faulted but there is no detailed information about the fault.	
	606		Control and power unit software are incompatible.	Update software. Should the fault re-occur, contact your distributor.
	607		Software version cannot be read. There is no software in the power unit.	Update power unit software. Should the fault re-occur, contact your distributor.
	608		CPU overload. Part of the software (for example, the application) has caused an overload situation. The source of the fault has been suspended.	Reset the fault and restart. Should the fault re-occur, contact your distributor.
	609		Memory access has failed. For example, retain variables could not be restored.	
	610		Necessary device properties cannot be read.	
	647		Software error.	Update the software. Should the fault re-occur, contact your distributor.
	648		Invalid function block used in application. System software and application are not compatible.	
	649		Resource overload. Error when loading parameter initial values. Error when restoring parameters. Error when saving parameters.	
9	80	Undervoltage (fault)	DC-link voltage is under the voltage limits defined. <ul style="list-style-type: none"> ● Most probable cause: too low a supply voltage ● AC drive internal fault ● Defect input fuse ● External charge switch not closed NOTE: This fault is activated only if the drive is in Run state.	In case of temporary supply voltage break reset the fault and restart the AC drive. Check the supply voltage. If it is adequate, an internal failure has occurred. Contact your distributor.
	81	Undervoltage (alarm)		
10	91	Input phase	Input line phase is missing.	Check supply voltage, fuses and cable.
11	100	Output phase supervision	Current measurement has detected that there is no current in one motor phase.	Check motor cable and motor.
13	120	AC drive undertemperature (fault)	Too low temperature measured in power unit's heatsink or board. Heatsink temperature is under -10° C (14° F).	
	121	AC drive undertemperature (alarm)		

Fault Code	Fault ID	Fault Name	Possible Cause	Remedy
14	130	AC drive overtemperature (fault, heatsink)	Too high temperature measured in power unit's heatsink or board. Heatsink temperature is over 100° C (212° F).	Check the correct amount and flow of cooling air. Check the heatsink for dust. Check the ambient temperature. Make sure that the switching frequency is not too high in relation to ambient temperature and motor load.
	131	AC drive overtemperature (alarm, heatsink)		
	132	AC drive overtemperature (fault, board)		
	133	AC drive overtemperature (alarm, board)		
15	140	Motor stalled	Motor is stalled.	Check motor and load.
16	150	Motor overtemperature	Motor is overloaded.	Decrease motor load. If no motor overload exists, check the temperature model parameters.
17	160	Motor underload	Motor is underloaded.	Check load.
19	180	Power overload (short-time supervision)	Drive power is too high.	Decrease load.
	181	Power overload (long-time supervision)		
25		Motor control fault	Start angle identification has failed. Generic motor control fault.	
26	250	Start-up Prevent	It is not possible to do a startup of the drive. When the Run request is ON, new software (firmware or an application), a parameter setting, or other file that affects the operation of the drive is loaded to the drive.	Reset the fault and stop the drive. Load the software and start the drive.
30	500	Safety Configuration	Appears when safety configuration switch has been installed.	Remove the safety configuration switch from the control board.
	501	Safety Configuration	Too many STO option boards have been detected in the drive, only one is supported.	Remove the extra STO option boards.
	502	Safety Configuration	STO option board has been installed in incorrect slot.	Place the STO option board in the correct slot.
	503	Safety Configuration	Safety configuration switch is missing from the control board.	Install the safety configuration switch on the control board.
	504	Safety Configuration	Safety configuration switch has been installed incorrectly on the control board.	Install the safety configuration switch in correct place on the control board.
	505	Safety Configuration	Safety configuration switch on the STO option board has been installed incorrectly.	Check the safety configuration switch installation on the STO option board.
	506	Safety Configuration	Communication with the STO option board has been lost.	Check the installation on the STO option board.
	507	Safety Configuration	Hardware does not support STO option board	Reset the drive and restart. If the fault reoccurs, contact Technical Support.
<p>When the RS-485 wiring is physically located too close to the input power and/or motor output wiring, this fault can occur. When the RS-485 wiring is not properly grounded per <i>Siemens BT300 HVAC Drive Installation Instructions</i> (DPD01148) , this fault can occur. When the STO jumper is not installed in the correct position, this fault can occur.</p>				

Fault Code	Fault ID	Fault Name	Possible Cause	Remedy
32	312	Fan cooling	Fan life time is up.	Change fan and reset fan life time counter.
33		Fire mode enabled	Fire mode of the drive is enabled. The drive's protections are not in use.	
37	360	Device changed (same type)	Option board changed for one previously inserted in the same slot. The board's parameter settings are saved.	Device is ready for use. Old parameter settings will be used.
38	370	Device changed (same type)	Option board added. The option board was previously inserted in the same slot. The board's parameter settings are saved.	Device is ready for use. Old parameter settings will be used.
39	380	Device removed	Option board removed from slot.	Device no longer available.
40	390	Device unknown	Unknown device connected (power unit/option board).	Device no longer available.
41	400	IGBT temperature	IGBT temperature (unit temperature + I_2T) is too high.	Check loading. Check motor size. Make identification run.
43	420	Encoder fault	Encoder 1 channel A is missing.	Check encoder connections. Check encoder and encoder cable. Check encoder board. Check encoder frequency in open loop.
	421		Encoder 1 channel B is missing.	
	422		Both encoder 1 channels are missing.	
	423		Encoder reversed.	
	424		Encoder board missing	
44	430	Device changed (different type)	Option board changed for one not present in the same slot before. No parameter settings are saved.	Reset the option board parameters.
45	440	Device changed (different type)	Option board added. The option board was not previously present in the same slot. No parameter settings are saved.	Reset the option board parameters.
50	1050	AI Low Fault	One or more of the available analog input signals is below 50% of the minimum signal range. A control cable is defective or loose. There is a malfunction in the signal source.	Verify I/O A Ctrl Ref (P3.3.3) for proper selection of analog input. Verify the AI1 Signal Range (P3.5.2.3) or AI2 Signal Range (P3.5.2.9). Replace the defective parts. Verify the analog input signal. Verify the analog input signal ranges are properly programmed.
51	1051	External fault	Digital input.	
52	1052 1352	Keypad communication fault	The connection between the control keypad and variable frequency drive is broken.	Check keypad connection and possible keypad cable
53	1053	Fieldbus communication fault	The data connection between the fieldbus master and fieldbus board is broken.	Check installation and fieldbus master.
54	1354	Slot A fault	Defective option board or slot.	Check board and slot.
	1454	Slot B fault		
	1554	Slot C fault		
	1654	Slot D fault		
	1754	Slot E fault		
65	1065	PC communication fault	The data connection between the computer and variable frequency drive is broken.	

66	1066	Thermistor fault	The thermistor input has detected an increase of motor temperature.	Check motor cooling and load. Check thermistor connection (If thermistor input is not in use it must be short circuited)
69	1310	Fieldbus mapping error	Non-existing ID number is used for mapping values to Fieldbus Process Data Out.	Check parameters in Fieldbus Data Mapping menu.
	1311		Not possible to convert one or more values for Fieldbus Process Data Out.	The value being mapped may be of an undefined type. Check parameters in the Fieldbus Data Mapping menu.
	1312		Overflow when mapping and converting values for Fieldbus Process Data Out (16-bit).	
80	1080	Remote Safety 1*	Digital input	Verify the status of the digital input as defined by Remote Safety 1 (P3.5.1.44).
	1180	Remote Safety 2*		Verify the status of the digital input as defined by Remote Safety 2 (P3.5.1.45).
	1280	Remote Safety 3*		Verify the status of the digital input as defined by Remote Safety 3 (P3.5.1.46).
	1380	Remote Safety 4*		Verify the status of the digital input as defined by Remote Safety 4 (P3.5.1.47).
	1480	Remote Safety 5*		Verify the status of the digital input as defined by Remote Safety 5 (P3.5.1.48).
	1580	Remote Safety 6*		Verify the status of the digital input as defined by Remote Safety 6 (P3.5.1.49).
	1680	Remote Safety 7*		Verify the status of the digital input as defined by Remote Safety 7 (P3.5.1.50).
	1780	Remote Safety 8*		Verify the status of the digital input as defined by Remote Safety 8 (P3.5.1.51).
81	1081	Overload**	Overload Relay has triggered the fault.	Reset the overload relay in the bypass cabinet.
82	1082	Bypass Not Possible*	OPT-B5 relay board is missing. Bypass is not possible without the relay board.	Verify connection of the OPT-B5 option board in Slot C, D, or E. Install if required when power is not applied to the drive.
83	1083	Essential Services*	Essential Services activated through digital input.	Verify the status of the digital input as defined by Essential Services (P3.5.1.52). Verify the status of the EssentServEnable (P3.18.5).
84	1084	Run Interlock Proof	The run interlock proof has failed to be provided within the time allotted in Run Interlock Proof (P3.2.13).	Verify proper operation of the proof feedback source.
101	1101	Process supervision fault (PID1)	PID controller: Feedback value outside of supervision limits (and the delay if set).	
105	1105	Process supervision fault (PID2)	PID controller: Feedback value outside of supervision limits (and delay, if set).	

* Faults only possible with an Electronic Bypass Option.

** Faults only possible with a Bypass Option.

Chapter 6 - Technical Information

This chapter provides general technical information for the BT300 Variable Frequency Drive.

Product Numbers

	Example: BT300	-	0	0	1	X	2	-	0	1	X
	Example: BT300	-	0	0	1	5	4	-	1	2	D
Model(s)	BT300 VFD Only										
Separator											
HP	1 ¹⁾ , 1.5 ²⁾ , 2 ²⁾ , 3, 5, 7.5, 10, 15, 20, 25, 30, 40, 50, 60, 75 ³⁾ , 100 ³⁾ , 125 ³⁾ , 150 ⁴⁾ , 200 ⁴⁾ , 250 ⁵⁾										
	X = no fraction, 5 = 1/2 hp										
Voltage											
	2	208 Vac to 240 Vac									
	4	380 Vac to 500 Vac									
	6	525 Vac to 600 Vac									
Separator											
NEMA											
	00 ⁶⁾	Chassis Version (IP 00)									
	01	NEMA Type 1 (IP 21)									
	12	NEMA Type 12 (IP 54)									
Type											
	X	Drive Only									
	D	Disconnect ⁷⁾									

BT0115R3

- ¹⁾ Available only with voltage code 2.
- ²⁾ Available only with voltage code 2 or 4.
- ³⁾ Use with voltages equal to or greater than 230 Vac.
- ⁴⁾ Available only with voltage code 4 or 6.
- ⁵⁾ Available only with voltage code 4.
- ⁶⁾ Available only with 50 hp and above @ 208 Vac or 100 hp and above @ 480 Vac (FS8 and FS9).
- ⁷⁾ Available only with NEMA Type 12 with 30 hp and below @ 240 Vac or 60 hp and below @ 480 Vac or 50 hp and below @ 600 Vac.

Example Product Numbers:

BT300-001X2-01X

BT300, 1 hp, 208 to 240 Vac, NEMA Type 1, Drive Only

BT300-00154-12D

BT300, 1.5 hp, 380 to 500 Vac, NEMA Type 12, Drive with disconnect

Figure 37:

Power Ratings

The following chart shows the BT300 HVAC Drive power ratings in accordance with frame sizes:

		Voltage											
		208-240	380-500	525-600	208-240	380-500	525-600	208-240	380-500	525-600	208-240	380-500	525-600
HP	kW	Frame Size			Input Current			Output Current			10% OL Current		
1	0.75				4.2			4.8			5.3		
1.5	1.1	4	4		6.0	3.4		6.7	3.4		7.4	3.7	
2	1.5				7.2	4.6		8.0	4.8		8.8	5.3	
3	2.2				9.7	5.4		2.7	11.0		5.6	3.9	
5	4	5	4	5	16.1	9.3	3.9	18.0	9.6	6.1	19.8	10.6	6.7
7.5	5.5				21.7	11.3	6.1	24.2	12.0	9.0	26.6	13.2	9.9
10	7.5				27.7	15.4	9.0	31.0	16.0	11.0	34.1	17.6	12.1
15	11	6	5	6	43.8	21.3	13.5	48.0	23.0	18.0	52.8	25.3	19.8
20	15				57.0	28.4	18.0	62.0	31.0	22.0	68.2	34.1	24.2
25	18.5	7	6	7	69.0	36.7	22.0	75.0	38.0	27.0	82.5	41.8	29.7
30	22				82.1	43.6	27.0	88.0	46.0	34.0	96.8	50.6	37.4
40	30				99.0	58.2	34.0	105.0	61.0	41.0	115.5	67.1	45.1
50	37	8	7	8	135.1	67.5	41.0	143.0	72.0	52.0	157.3	79.2	57.2
60	45				162.0	85.3	52.0	170.0	87.0	62.0	187.0	95.7	68.2
75*	55				200.0	100.6	62.0	208.0	105.0	80.0	228.8	115.5	88.0
100*	75	9	8	9	253.0	139.4	80.0	261.0	140.0	100.0	287.1	154.0	110.0
125*	90				301.0	166.5	100.0	310.0	170.0	125.0	341.0	187.0	137.5
150	110				199.6	125.0		205.0	144.0		225.5	158.4	
200	132				258.0	170.0		261.0	208.0		287.1	228.8	
250	160				303.0			310.0			341.0		

* For use with 230 Vac and above.

Interpreting Serial Numbers and Date Codes

Each BT300 HVAC Drive has a manufacturing/serial number. The date code is part of the serial number. The following example shows how to interpret the date code and serial number:

Serial Numbers

Example:	C - 1 3 1 0 0 0 7 4 7
Manufacturing Location	C
Separator	-
Year	13
Week	10
Sequence Number	000747

BT0112R2

Technical Data

Table 139: Drive Specifications.

Specification	Description
Input Voltages and Power Ranges (3-phase)	208 to 240 Vac (-10% to +10%): 1 hp to 125 hp (0.75 kW to 90 kW) 380 to 500 Vac (-10% to +10%): 1.5 hp to 250 hp (1.1 kW to 160 kW) 525 to 600 Vac (-10% to +10%): 3 hp to 200 hp (2.2 kW to 132 kW)
Input Frequency	45 to 66 Hz (50 to 60 Hz; -5% to +10%)
Output Voltage	0 to Input voltage
Output Frequency	0 to 320 Hz
Output Frequency Resolution	0.01 Hz
Efficiency	>97.5%
PWM (switching) frequency	FS4 to FS6 - 1.5 to 10 kHz Default FS4: 6 kHz; FS5: 4 kHz; FS6 = 4 kHz FS7 to FS9 - 1.5 to 6 kHz Default FS7: 4 kHz; FS8: 3 kHz; FS9: 2kHz Adjustable in .1 kHz increments Automatic switching frequency derating in case of overheating
Short circuit withstand rating	100,000 AIC
Frequency Reference Analog Input Keypad	Resolution 0.01 to 0.1% (10 bit), accuracy $\pm 1\%$ Resolution 0.01 Hz
Field weakening point	8 to 320 Hz
Acceleration time	0.1 to 3000.0 seconds
Deceleration time	0.1 to 3000.0 seconds
Ambient Operating Temperature	14° F (-10° C) (no frost) to 104° F (40° C) up to 122° F (50° C) with derating
Relative Humidity	0 to 95% rh, non-condensing, non-corrosive
Air quality: Chemical vapors Mechanical particles	IEC 60068-2-60 (H ₂ S [hydrogen sulfide] and SO ₂ [sulfur dioxide]). IEC 60721-3-3, unit in operation, class 3C2 IEC 60721-3-3, unit in operation, class 3S3.
Altitude	100% load capacity (no-derating) up to 3,280 ft (1,000 m) -1% derating for each 328 ft (100 m) above 3,280 ft (1,000 m) Maximum altitude: 208 to 240 Vac: 13,123 ft (4,000 m) 380 to 500 Vac: 13,123 ft (4,000 m) 525 to 600 Vac: 6,562 ft (2,000 m) Voltage for relay outputs: 240 Vac: $\leq 9,842$ ft (3,000 m) 120 Vac: $\leq 13,123$ ft (4,000 m) Corner-grounding (380 through 500 Vac systems only): $\leq 6,562$ ft (2,000 m)
Fixed frequencies	7 programmable
Skip (prohibited) frequency band	3 programmable
Vibration	EN61800-5-1 EN60068-2-6

Specification	Description
Seismic	2012 International Building Code (IBC), OSHPD
Shock	EN61800-5-1 EN60068-2-27
Enclosure Class	UL Type 1/IP 21 standard in entire HP/kW range. UL Type 12/IP 54 options
EMC Immunity	Fulfills IEC 61800-3 (2004), first and second environment
EMC Emissions	EN61800-3 (2004) Category C2 Can be field modified for IT networks for C3 or C4 ratings.
Embedded Protocols	RS-485: APOGEE P1, BACnet MS/TP (BTL), Modbus RTU, Metasys N2 Ethernet: BACnet IP (BTL), Modbus TCP
Heatsink cooling fan noise level in dB (low speed/high speed)	FS4: 45/56 FS5: 57/65 FS6: 63/72 FS7: 43/73 FS8: 58/73 FS9: 54/75
Heatsink cooling fan output	FS4: 49 CFM FS5: 88 CFM FS6: 219 CFM FS7: 159 CFM FS8: 426 CFM FS9: 560 CFM
Agency Approvals/Conformity	UL 508C; UL; cUL; CE; BTL ; RoHS compliant; EN61800-5-1 (2007).
Country Of Origin (COO)	Finland
Control Method	Linear, parabolic and programmable V/f; and flux current control low-power mode
Control I/O: Analog Inputs	2 - voltage (0/2 to 10 Vdc) or current (0/4 to 20 mA) Resolution 0.1%; Accuracy $\pm 1\%$
Analog Outputs	1 - voltage (0/2 to 10 Vdc) or current (0/4 to 20 mA) <500 W; Resolution 0.1%; Accuracy $\pm 1\%$
Digital Inputs	6 - programmable and isolated Positive or Negative logic; 5 kW; 0 to 5 Vdc = 0 ; 15 to 30 Vdc = 1
Relay Outputs	2 - Form C and 1 Normally Open 24 Vdc @ 8A; 250 Vac @ 8A; 125 Vac @ 0.4A
Auxiliary input	24 Vdc $\pm 10\%$, 250 mA
Auxiliary output	10 Vdc $\pm 3\%$, 10 mA (short-circuit protected) 24 Vdc $\pm 10\%$, 250 mA (short-circuit protected)

Specification	Description
Embedded Protocols	RS-485: APOGEE P1, BACnet MS/TP, Modbus RTU, Metasys N2 Ethernet: BACnet IP, Modbus TCP
Over voltage trip limit	208 to 240 Vac: 456 Vdc 380 to 500 Vac: 911 Vdc 525 to 600 Vac: 1094 Vdc
Under voltage trip limit	Depends on supply voltage (0.8775* supply voltage): 208 Vac: 182.5 Vdc 240 Vac: 210.6 Vdc 380 Vac: 333.5 Vdc 480 Vac: 421.2 Vdc 575 Vac: 504.6 Vdc
Protection features	Under-voltage trip limit Over-voltage trip limit Ground fault protection Input (mains) supervision Motor phase supervision Over-current protection Unit over-temperature protection Motor overload protection Motor stall protection Motor underload protection Short-circuit protection of 10 Vdc and 24 Vdc reference voltages

Control Board Technical Specifications

Table 140: Control Module Technical Specifications

Terminal	Signal/Description	Specification
Slot A		
1	+10 Vdc Reference Output	+3%; Maximum current 10 mA
2	Analog Input 1 Signal (+)	0 through 10 Vdc or 0 through 20 mA (selection with DIP switch) Resolution: 0.1%, Accuracy: ± 1%
3	Analog Input 1 Common (-)	
4	Analog Input 2 Signal (+)	0 through 10 Vdc or 0 through 20 mA (selection with DIP switch) Resolution: 0.1%, Accuracy: ± 1%
5	Analog Input 2 Common (-)	
6	24 Vdc Output Voltage	± 10%; Maximum 250 mA
7	I/O Ground	
8	Digital Input 1	Positive or negative logic; 0 Vdc - 5 Vdc = 0 ; 15 Vdc - 30 Vdc = 1
9	Digital Input 2	
10	Digital Input 3	
11	Common for DI 1 - DI 6	
12	24 Vdc Output Voltage	± 10%; Maximum 250 mA
13	I/O Ground	
14	Digital Input 4	Positive or negative logic; 0 Vdc - 5 Vdc = 0 ; 15 Vdc - 30 Vdc = 1
15	Digital Input 5	
16	Digital Input 6	

Terminal	Signal/Description	Specification
17	Common for DI 1 - DI 6	
18	Analog Output 1 Signal (+)	0 through 10 Vdc or 0 through 20 mA (selection with DIP switch) Resolution: 0.1%, Accuracy: ± 1%
19	Analog Output 1 Common (-)	
30	24 Vdc Input Voltage	± 10%; Maximum 250 mA; Used for power backup of control unit.
A	RS-485 -	Fieldbus Negative
B	RS-485 +	Fieldbus Positive
Slot B		
21	Relay Output 1 Normally Closed	Switching capacity: 24 Vdc/8A; 250 Vac/8A; 125 Vdc/0.4A Minimum switch load: 5 Vdc/0 mA
22	Relay Output 1 Common	
23	Relay Output 1 Normally Open	
24	Relay Output 2 Normally Closed	Switching capacity: 24 Vdc/8A; 250 Vac/8A; 125 Vdc/0.4A Minimum switch load: 5 Vdc/0 mA
25	Relay Output 2 Common	
25	Relay Output 2 Normally Open	
32	Relay Output 2 Common	Switching capacity: 24 Vdc/8A; 250 Vac/8A; 125 Vdc/0.4A Minimum switch load: 5 Vdc/0 mA
33	Relay Output 2 Normally Open	

Fieldbus Technical Data

	APOGEE P1	BACnet MS/TP	Modbus RTU	Metasys N2	BACnet IP	Modbus TCP
Interface	RS-485				100BaseT, 802.3	
Data Transfer Method	RS-485, half-duplex				Ethernet half/full duplex	
Transfer Cable	STP (Shielded Twisted Pair), Belden 9841 type or similar				CAT5e STP	
Connector	14 AWG (2.5 mm ²)				Shielded RJ45	
Baud Rate(s)	4800, 9600	9600, 19200, 38400, 76800	300, 600, 1200, 2400, 4800, 9600, 19200, 38400, 57600, 76800, 115200, 230400	9600	10/100 Mbits/s, auto-sensing	
Addresses	0 to 127	0 to 127	1 to 247	1 to 255	NA	

Accessories and Replacement Parts

Table 141: BT300 HVAC Drive Accessories and Replacement Parts (Frame Size-Specific).

Accessory Description		Frame Size		
		4	5	6
NEMA 1 to NEMA 12 Upgrade	NEMA 12 Cover	BT300-CVR-54-FS4	BT300-CVR-54-FS5	BT300-CVR-54-FS6
	NEMA 12 Gland Plate	BT300-EDPLT-54-FS4	BT300-EDPLT-54-FS5	BT300-EDPLT-54-FS6
	Internal Fan (for s/n C1407xxxx and earlier)	BT300-INTFAN-FS4	BT300-INTFAN-FS5	BT300-INTFAN-FS6
	Internal Fan (for s/n C1408xxxx and later)	BT300-INTFAN-456-F	BT300-INTFAN-456-F	BT300-INTFAN-456-F
Accessories Kit		BT300-ACCKIT-FS4	BT300-ACCKIT-FS5	BT300-ACCKIT-FS6
EMC Filter Kit		BT300-EMCKIT-FS4	BT300-EMCKIT-FS5	BT300-EMCKIT-FS6
Flange Mount Kit		BT300-FLG-FS4	BT300-FLG-FS5	BT300-FLG-FS6
Main Fan (heatsink)		BT300-MFAN-FS4	BT300-MFAN-FS5	BT300-MFAN-FS6
NEMA 1 Cover		BT300-CVR-21-FS4	BT300-CVR-21-FS5	BT300-CVR-21-FS6
NEMA 1 Gland Plate		BT300-EDPLT-N1-FS4	BT300-EDPLT-N1-FS5	BT300-EDPLT-N1-FS6
Accessory Description		Frame Size		
		7	8	8
NEMA 1 to NEMA 12 Upgrade	NEMA 12 Cover	BT300-CVR-2154-FS7	BT300-CVR-2154-FS8	N/A
	NEMA 12 Gland Plate	N/A	N/A	N/A
	Internal Fan (for s/n C1407xxxx and earlier)	BT300-INTFAN-FS7	BT300-INTFAN-FS8	BT300-INTFAN-FS9
	Internal Fan (for s/n C1408xxxx and later)			
Accessories Kit		BT300-ACCKIT-FS7	BT300-ACCKIT-FS8	BT300-ACCKIT-FS9
EMC Filter Kit		BT300-EMCKIT-FS7	N/A	N/A
Flange Mount Kit		BT300-FLG-FS7	N/A	N/A
Main Fan (heatsink)		BT300-MFAN-FS7	BT300-MFAN-FS8	BT300-MFAN-FS9
NEMA 1 Cover		BT300-CVR-2154-FS7	BT300-CVR-2154-FS8	N/A
NEMA 1 Gland Plate		N/A	N/A	N/A

Table 142: Accessories.

Part Number	Description
BT300-BATTERY	Battery package (5 pcs)
BT300-BATTERY-F	Battery package (5 pcs) for use with s/n 1408xxx and later
BT300-BYP-DEMO	VFD and Electronic Bypass Demo with carrying case
BT300-CABLE	USB to RS422 interface cable for computer-to-drive connection
BT300-CNTLUNIT	Control Module
BT300-CNTLUNIT-F	Control Module for use with s/n 1408xxx and later
BT300-HHPANEL	Hand held panel kit with magnetic base
BT300-KEYPAD	Graphical keypad

Part Number	Description
BT300-OPT-B1-V	Option board with six bi-directional terminals (digital input or digital output)
BT300-OPT-B2-V	Option board with one thermistor input and two relay outputs
BT300-OPT-B4-V	Option board with one analog input and two analog outputs
BT300-OPT-B5-V	Option board with three relay outputs
BT300-OPT-B9-V	Option board with five digital inputs and one relay output
BT300-OPT-BF-V	Option board with one analog output, one digital output and one relay output
BT300-OPT-BH-V	Option board with three analog inputs (for PT100, PT1000, NI 1000, KTY-84)
BT300-PNL-N12	NEMA 12 door keypad mounting kit



Issued by
Siemens Industry, Inc.
Smart Infrastructure
1000 Deerfield Pkwy
Buffalo Grove IL 60089
+1 847-215-1000

© Siemens Industry, Inc., 2019
Technical specifications and availability subject to change without notice.