

SSD Series Electronic Valve Actuator (For use with 1/2-Inch to 1-1/4-inch Pressure Independent Control Valves)

Product Description

The SSD Actuator requires a 24 Volt power supply and a 0 to 10 Vdc or floating control signal to control the 1/2-inch to 1-1/4-inch Siemens 599 Series Pressure Independent Control Valves with a 1/10-inch (2.5 mm) or 7/32-inch (5 mm) stroke.

Contents

SSD61U, SSD81U:

- One actuator
- One terminal plug
- One terminal connector



SSD61.5U, SSD81.5U:

- One actuator

Product Numbers

Product Number	Description	Actuator Code
SSD61U	0 to 10 Vdc control, NSR	231
SSD81U	Floating control, NSR	230
SSD61.5U	0 to 10Vdc control, SR	233
SSD81.5U	Floating control, SR	232

Warning/Caution Notations

WARNING:		Personal injury/loss of life may occur if you do not follow a procedure as specified.
CAUTION:		Equipment damage may occur if you do not follow a procedure as specified.

Required Tools

- 3 mm hex wrench
- Small flat-blade screwdriver
- Small, Phillips screwdriver
- Wire stripper

Expected Installation Time

20 minutes

Prerequisites



Figure 1. Acceptable Mounting Positions.

NOTE: Vertical mounting position recommended.

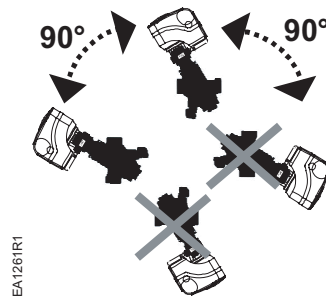

Figure 2. Acceptable Mounting Position with Valve.

NOTE: Vertical mounting is recommended.



WARNINGS:

- If mounting the actuator to a valve already in line, either close the shut-off valves in the piping (upstream first, then downstream), or switch off the pump to allow the differential pressure in the valve to drop.
- Disconnect the controller power before replacing the actuator. See *Removing an SSD61.5U/SSD81.5U Actuator from a Valve*.



CAUTION:

- Before applying power, make certain a valve is connected to the actuator.
- If applying power to the actuator when a valve is not connected, the actuator will respond to a control signal and the shaft will extend until it reaches its maximum end stop. Thereafter, it will not respond to any signal.
- If this occurs, disconnect the power. Insert a 3mm hex wrench into the manual override feature and retract the actuator to the zero position. Verify the actuator shaft is retracted completely. See Figure 14.
- Connect a valve to the actuator, reapply the power, and the actuator will return to normal operation.

Installation

Mounting an SSD61U/SSD81U Actuator on a Valve

1. Remove the protective plastic cap from the valve. See Figure 3.



Figure 3. Remove Plastic Cap.

2. Using a 3 mm hex wrench, turn the manual-position indicator on the top of the actuator to "0".
3. Attach the wires to the terminal plug. (Reference Wiring, See Figure 8 and Figure 11.)
4. Insert the terminal plug into the terminal connector. See Figure 4.

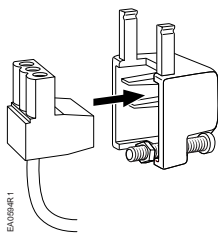

Figure 4. Terminal Plug and Terminal Connector.

5. Place the terminal connector and plug into the actuator, fitting the nut into the recess in the bottom of the actuator. See Figure 5.

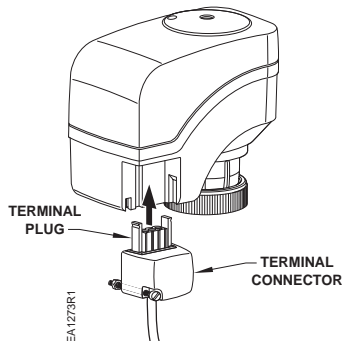

Figure 5. Insert Terminal Connector.

6. Tighten the screw to hold the connector in place. See Figure 6.

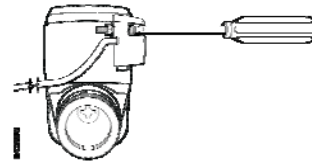

Figure 6. Tighten the Screw.

7. Place the actuator on the valve and firmly hand-tighten the coupling clockwise. See Figure 7.

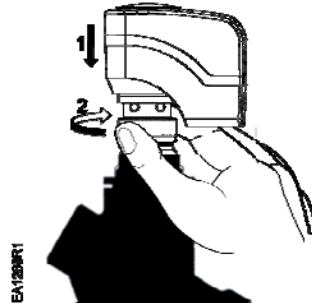

Figure 7. Hand-Tighten Clockwise.

NOTE: Be sure the visual position indicator is at the "0" position.

Installation is complete.

Mounting an SSD61.5U/SSD81.5U Actuator on a Valve

1. If you are attaching the actuator to a new valve, remove the protective plastic cap from the valve stem.
2. Use a 3mm hex wrench to retract the actuator to the 0 position (Figure 14).
3. Using a Phillips head screwdriver, remove the terminal cover (Figure 16).
4. Remove wiring retention screw.
5. Remove plenum cable adapter.
6. For plenum applications, complete wiring as follows:

- a. Route cable through plenum cable adapter so there is sufficient cable to complete wiring terminations.
- b. Insert plenum cable adapter into flex conduit adapter and secure in place with wiring retention screw.

NOTE: Insert wiring retention screw in hole of the flex conduit adapter. (The hole nearest the wiring terminals is to secure the terminal cover in place.)

- c. Continue with Step 8.
7. For 3/8-inch flex conduit applications, complete wiring as follows:
 - a. Discard plenum cable adapter.

- b. Insert flex conduit into flex conduit adapter and secure in place with wiring retention screw.
- NOTE:** Insert wiring retention screw in hole of the flex conduit adapter. (The hole nearest the wiring terminals is to secure the terminal cover in place.)

- c. Route wiring through flex conduit for wiring terminations.
- Connect wires to wiring terminals per the *Wiring* section of this document.
 - Secure the terminal cover in place over the wiring terminals (**Figure 16**) using a Phillips head screwdriver,
 - Place the actuator on the valve and firmly hand-tighten Figure 7.



CAUTION:
 Hand-tighten the actuator to the valve. The use of tools to tighten the assembly together will cause damage.

The installation is complete.

Wiring

- All wiring must conform to NEC and local codes and regulations.
- Use earth ground isolating step-down Class 2 transformers.
- Do not use autotransformers.
- Determine the supply transformer rating by summing the total VA of all actuators used.
- The maximum rating for a Class 2 step-down transformer is 100 VA.
- It is recommended that one transformer power no more than 10 actuators.

SSD81U

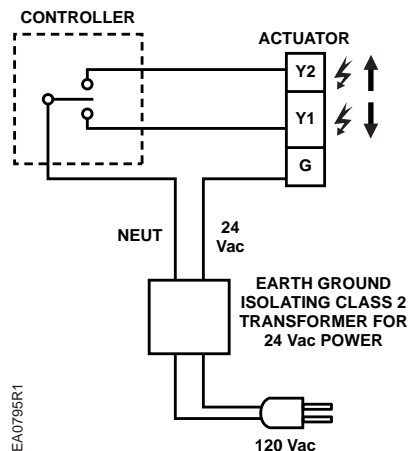

Figure 8. SSD81U Wiring Diagram.

Table 1. SSD81U Terminal Designations.

G	24 Vac Operating Voltage
Y1	Output shaft extends, valve opens
Y2	Output shaft retracts, valve closes

SSD81.5U

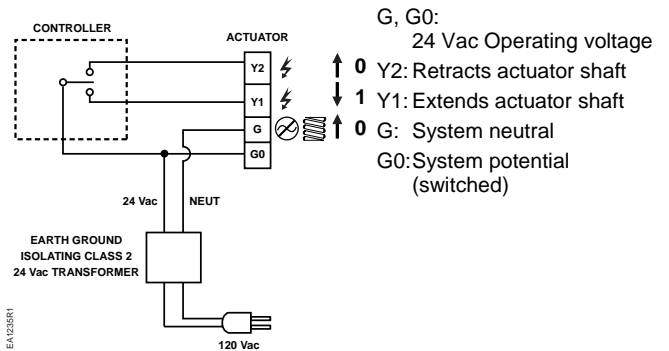

Figure 9. SSD81.5U Floating Control SR Hot-Switch.



CAUTION:
 Terminals must be properly wired for correct function and full life of the actuator.

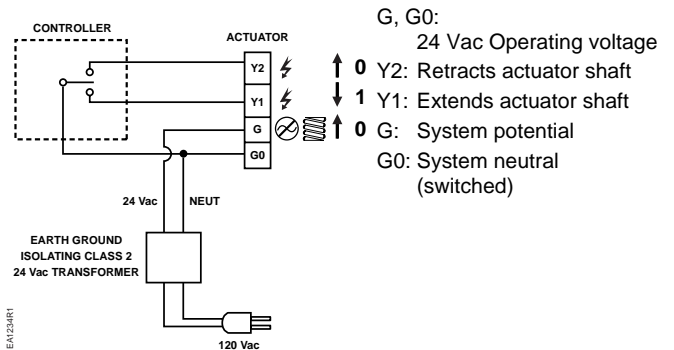

Figure 10. SSD81.5U Floating Control SR Neutral Switching Applications.

NOTE: For proper operation, it is recommended no more than three actuators be assigned to any single control signal.

SSD61U/SSD61.5U

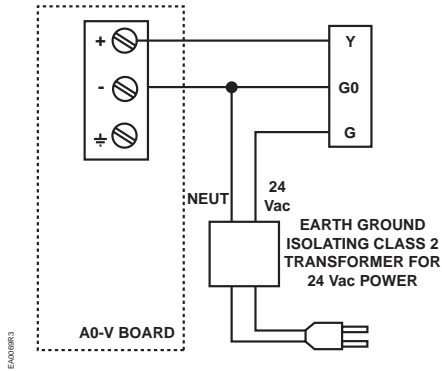

Figure 11. SSD61U/SSD61.5U Wiring Diagram.

Table 2. SSD61U Terminal Designations.

G, G0	24 Vac operating voltage
G	System potential, 24 Vac
G0	System neutral
Y	0 to 10 Vdc control signal



WARNING:

On the SSD61U/SSD61.5U the wire connection G is 24 Vac, system potential (HOT), not System neutral (ground).



CAUTION:

G0 and G must be properly wired for the correct function and full life of the actuator.

Start Up

Check the wiring and the position indication. See Figure 12 for referred positions "0" and "1" on the position indicator.

- When the position indicator disc rotates to position "1", the output shaft is extended.
- When the position indicator disc is at the "0" position the output shaft is retracted.

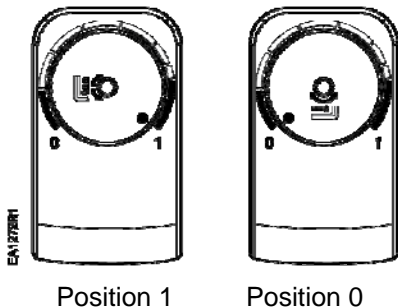

Figure 12. Visual Position Indication.

Note:
 The "0" and "1" position markings are intended for reference only and not for stroke measurement.

Calibration Stroke

The SSD61.5U writes its calibration stroke parameters to non-volatile memory on the first start-up of the actuator. Successive start-ups bypass the calibration stroke unless the memory is manually cleared. If installing the actuator on a different valve (such as on a replacement valve), manually clear the calibration stroke from memory as follows:

1. Remove the terminal cover using a Phillips head screwdriver.
2. Locate hole on the circuit board with the shorting bars. See Figure 13.
3. With power applied to the unit, insert and gently twist a flat-blade screwdriver to electrically connect the shorting bars. The SSD61.5U then performs a new calibration stroke.
4. Secure the terminal cover back in place.

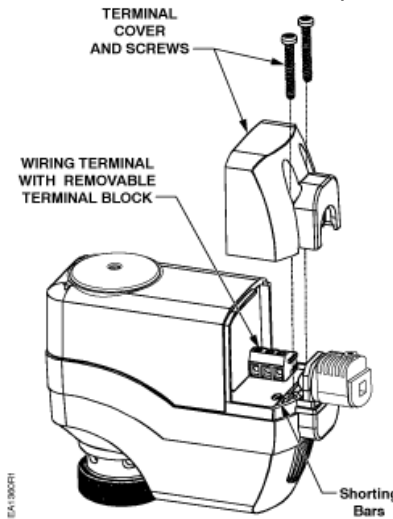

Figure 13. Manually Clearing Calibration Stroke from SSD61.5U Non-volatile Memory.

Manual Override

A 3 mm hex wrench can be used to move the actuator to any position between 0 and 1.

NOTE: A control signal from the controller takes priority in determining the position.

To retain the manually set position, unplug the connecting cable or switch off power and the control signal.



CAUTION:

SSD61U/SSD61.5U: If an override is performed while the power supply is connected, the actuator will not track accurately when the control signal is applied. A short power off/power on sequence is required to recalibrate the actuator.

Turn the wrench clockwise to extend the actuator shaft (counterclockwise to retract).

The actuator will maintain its position until power is provided or restored.

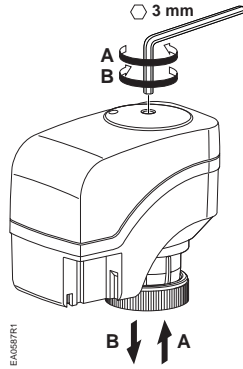

- (A) Turn hex wrench counterclockwise to retract the shaft.
- (B) Turn hex wrench clockwise to extend the shaft.

Figure 14. Manual Override.

Removing an SSD61U/SSD81U Actuator from a Valve

1. Loosen the terminal connector with a flat-blade screwdriver.
2. Remove the terminal connector and the terminal plug from the actuator.

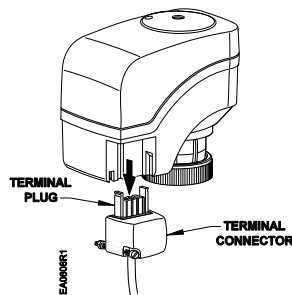

Figure 15. Removing Terminal Plug.

3. Remove the terminal plug from the connector and save.
4. Loosen the actuator coupling, turn counterclockwise.
5. Remove the actuator from the valve.

NOTE: Valve goes to closed position.

Removing an SSD61.5U/SSD81.5U Actuator from a Valve

1. Remove the terminal cover (Figure 16) using a Phillips head screwdriver.
2. Identify and disconnect wiring from the terminals.
3. Remove wiring retention screw.
4. Do one of the following:
 - Remove plenum cable adapter and plenum cable; *or*
 - Remove flex conduit.
5. Loosen the actuator coupling on the valve (Figure 7, reverse #2).
6. Remove the actuator from the valve.

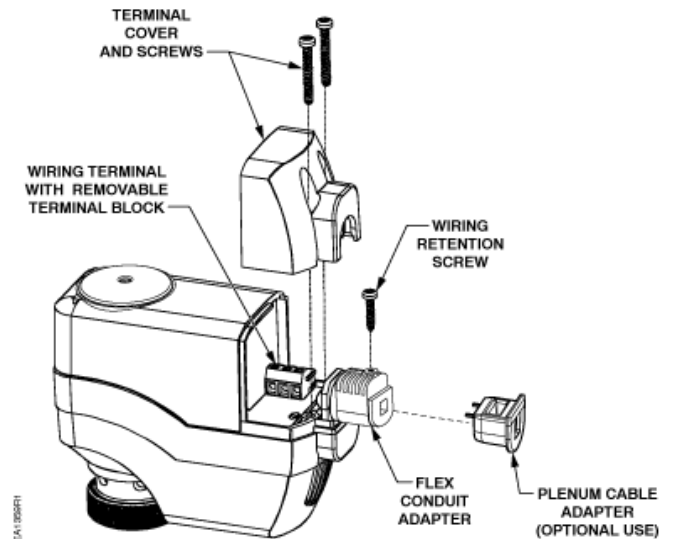

Figure 16. SSD61.5U/SSD81.5U Actuator Components.

Troubleshooting

- Check the wiring for the proper connections.
- If actuator becomes inoperable, replace the unit.

References

Technical Instructions	Document Number
SSD Series Electronic Valve Actuator	155-773
Pressure Independent Control Series 2-Way, Brass Valve Bodies, 1/2-inch to 2-inch, ANSI 250	155-774

Dimensions

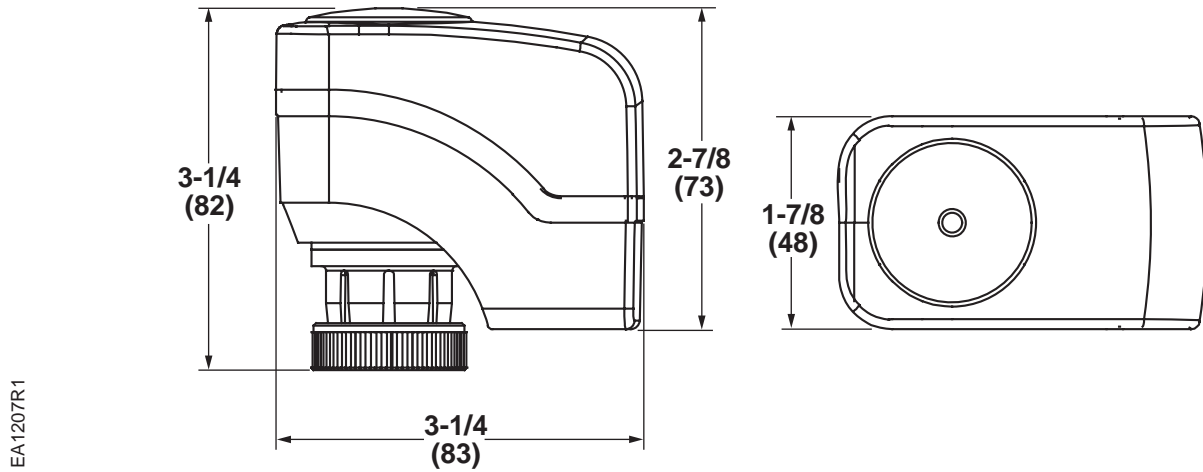

Figure 17. SSD61U/SSD81U Actuator in Inches (Millimeters).

Dimensions

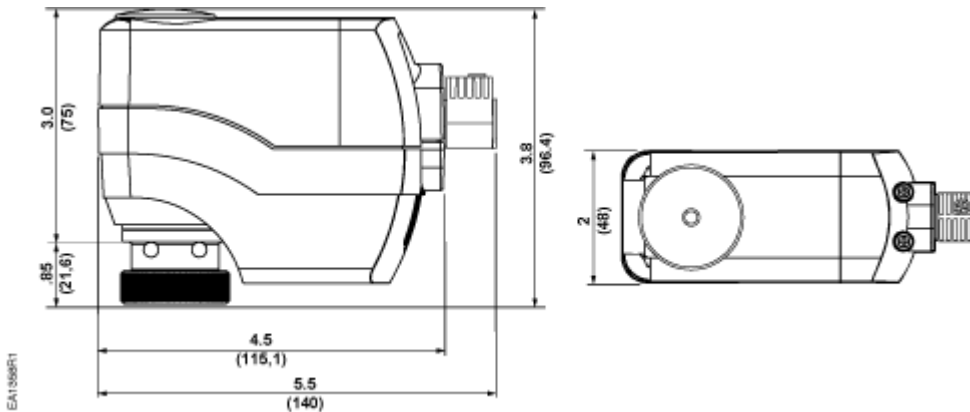

Figure 18. SSD61.5U/SSD81.5U Actuator Dimensions in Inches (Millimeters).

Service Envelope

Minimum access space recommended:

1. 8 inches (200 mm) above the actuator.
2. 8 inches (200 mm) beside the terminal cover.

Information in this publication is based on current specifications. The company reserves the right to make changes in specifications and models as design improvements are introduced. Product or company names mentioned herein may be the trademarks of their respective owners. © 2013 Siemens Industry, Inc.