

S-SERIES FURNACE

75011112

REV.
A

Upflow

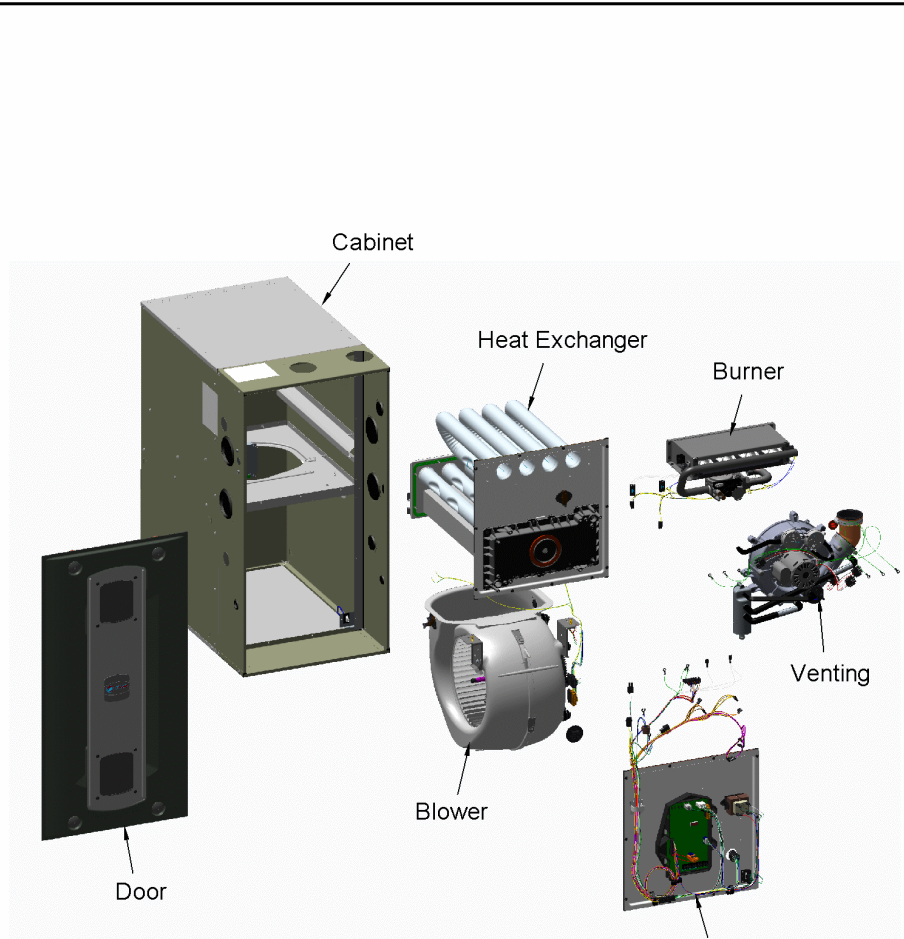

This is a typical illustration. The unit in the field may not appear exactly as shown.

Part No.	Reference No.	Quantity	Description
75011091#S9V2UP1~S	*		BLOWER
75011113#S9V2UP1~S	*		BURNER
75010934#S9V2UP1~S	*		CABINET
75010935#S9V2UP1~S	*		CONTROLS
75011003#S9V2UP1~S	*		FRONT DOOR PANEL
75011114#S9V2UP1~S	*		HEAT EXCHANGER
75011115#S9V2UP1~S	*		INDUCER & VENTING
75011116#S9V2UP1~S	*		MODEL NUMBER DESCRIPTION
S9V2ACCY#S9V2UP1~S	*		OPTIONAL ACCESSORIES
75011112_S9V2UP1_191255~P	*		S-SERIES FURNACE PARTS LIST
75011131#S9V2UP1~S	*		SHIP WITH PARTS

S-SERIES FURNACE

75011112

REV.
A

Upflow

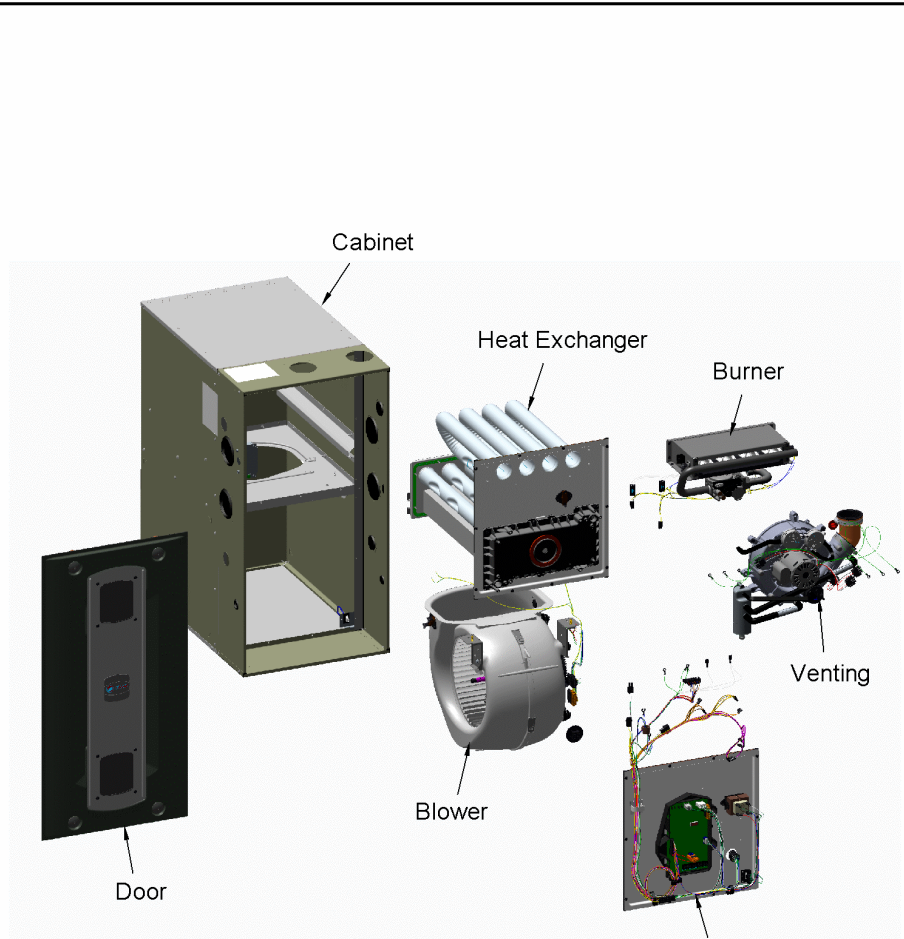

This is a typical illustration. The unit in the field may not appear exactly as shown.

CONTROLS

75010935

REV.
A

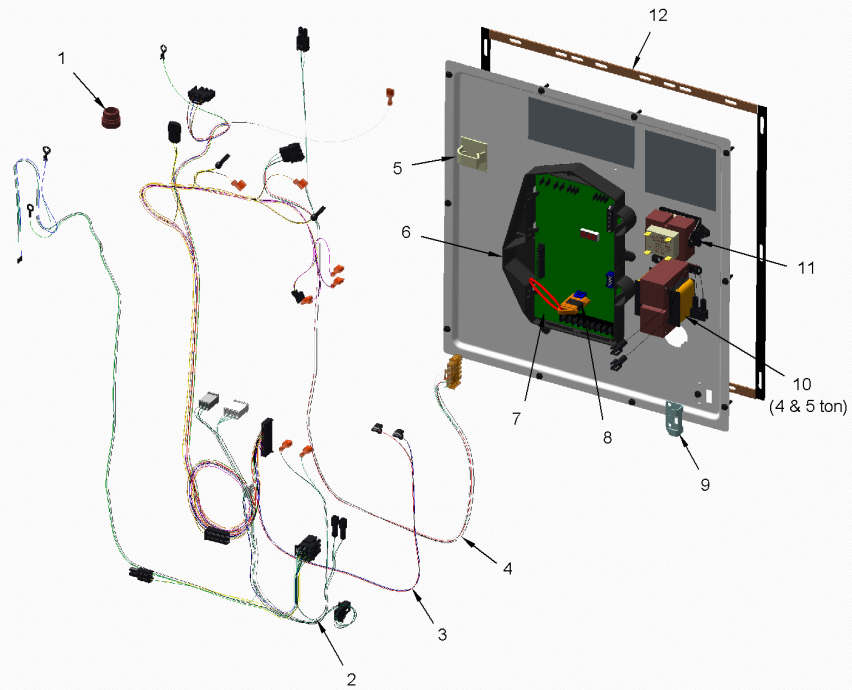

This is a typical illustration. The unit in the field may not appear exactly as shown.

CONTROLS

Parts List Number :75011112#S9V2UP1

Model Number :S9V2C100U4PSBBB

Part No.	Reference No.	Quantity	Description
75010935_S9V2UP1_238116~P	*		CONTROLS PARTS LIST

CONTROLS

75010935

REV.
A

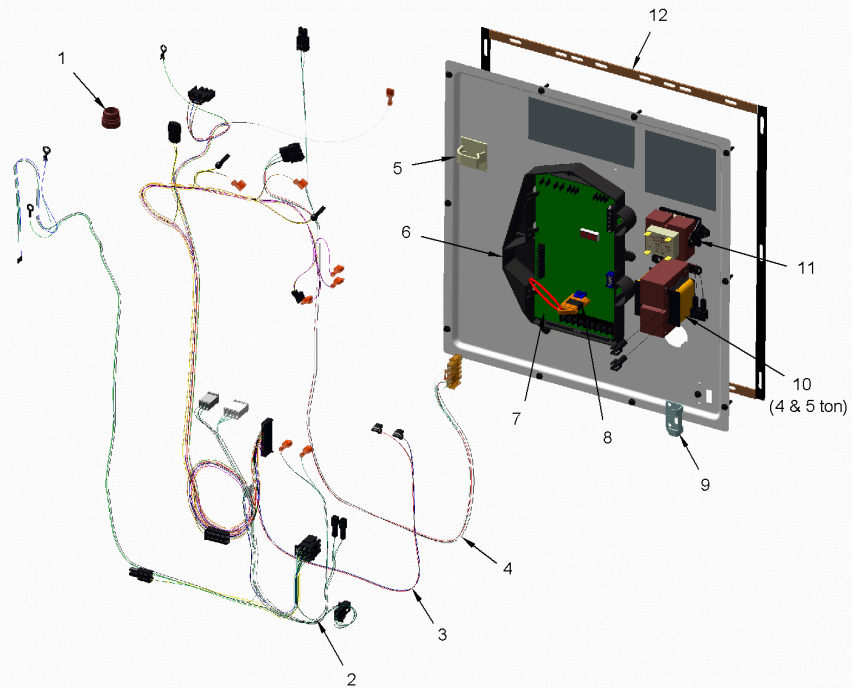

This is a typical illustration. The unit in the field may not appear exactly as shown.

Part No.	Reference No.	Quantity	Description
BUS00300	1	1	BUSHING; STRAIN RELIEF
WIR08829	2	1	WIRE; HARNESS, POWER, UPFLOW (BLK, WHT, BLU, GRN/YL, GRN, YEL WIRES)
WIR07909	3	1	WIRE; HARNESS; CONTROLS, UPFLOW (PUR, BLU, YEL, RED, BRN, GRN, ORG, WHT WIRES)
WIR07913	4	1	WIRE; HARNESS, BLOWER INDUCER/IGNITER, UPFLOW (BLK, RED, WHT WIRES)
MNT02457	5	1	MOUNT; WIRE HARNESS, MCLIP-BEVEL ENTRY, MOLDED, 1.49 X 1.46 X 0.89, 6/6 NYLON WITH FOAM ADHESIVE TAPE
CNT07721	7	1	CONTROL; W/ IFC, 2 STAGE FURNACE CONTROL
MOD01574	8	1	MODULE; TO ORDER-SEE EXT NOTE
BRK02173	9	1	BRACKET; INNER BLOWER DOOR DISCONNECT SWITCH
TRR02737	10	1	TRANSFORMER; CHOKE LINE, 12 AMPS RMS AC, 600V
TRR02736	11	1	TRANSFORMER; 115V-24V, 35VA, 60 HZ, CLASS 2
GKT04786	12	1	GASKET; VESTIBULE GASKETS, ONE SIZE FITS ALL - TRIM TO FIT

Part No.	Reference No.	Quantity	Description
S9V2ACCY_S9V2UP1_191274-P	*		OPTIONAL ACCESSORIES PARTS LIST

NO GRAPHIC AVAILABLE

75013702

REV
A

**NO
GRAPHIC
AVAILABLE**

Part No.	Reference No.	Quantity	Description
BAYAIR30AVENTA	*	1	VENT; CONCENTRIC VENT KIT, (BAYAIR30AVENTAA)
BAYAIR30CNVENT	*	1	KIT-CONCENTRIC-VENT-CANADA
BAYLPSS400A	*	1	KIT; LP CONVERSION KIT W/ (6) STAINLESS STEEL BURNERS, SEN02662, KIT01495 & KIT07611
BAYVENT200B	*	1	KIT; SIDE WALL VENT ASSEMBLY
BAYVENTCN200B	*	1	KIT-VENT-SIDE-WALL-CANADA

BLOWER

75011091

RB
B

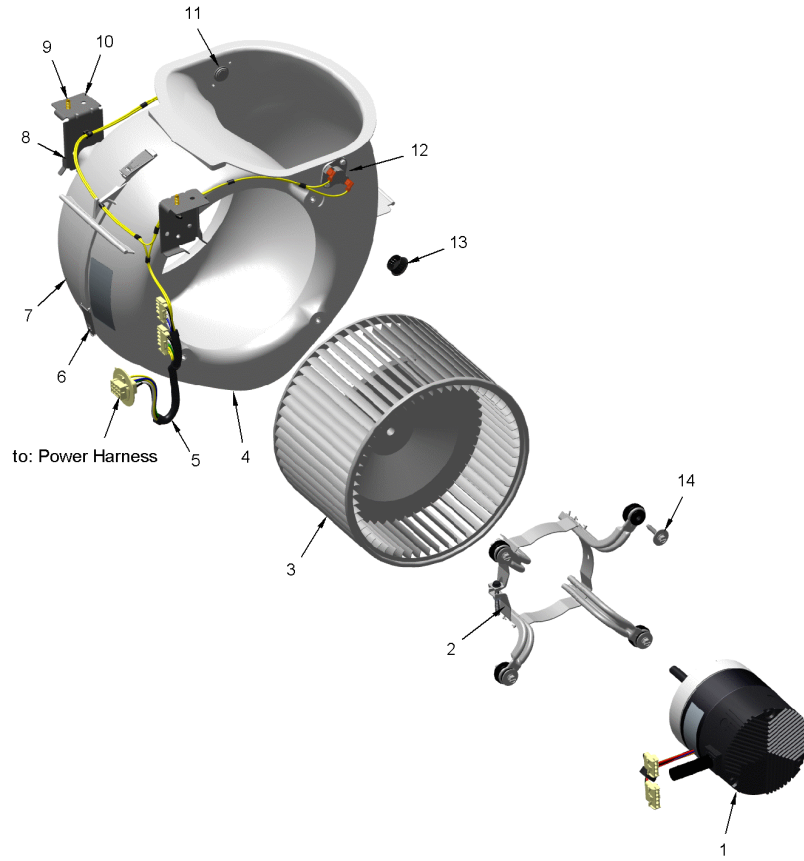

This is a typical illustration. The unit in the field may not appear exactly as shown.

Part No.	Reference No.	Quantity	Description
75011091_S9V2UP1_322814~P	*		BLOWER PARTS LIST

BLOWER

75011091

RB
B

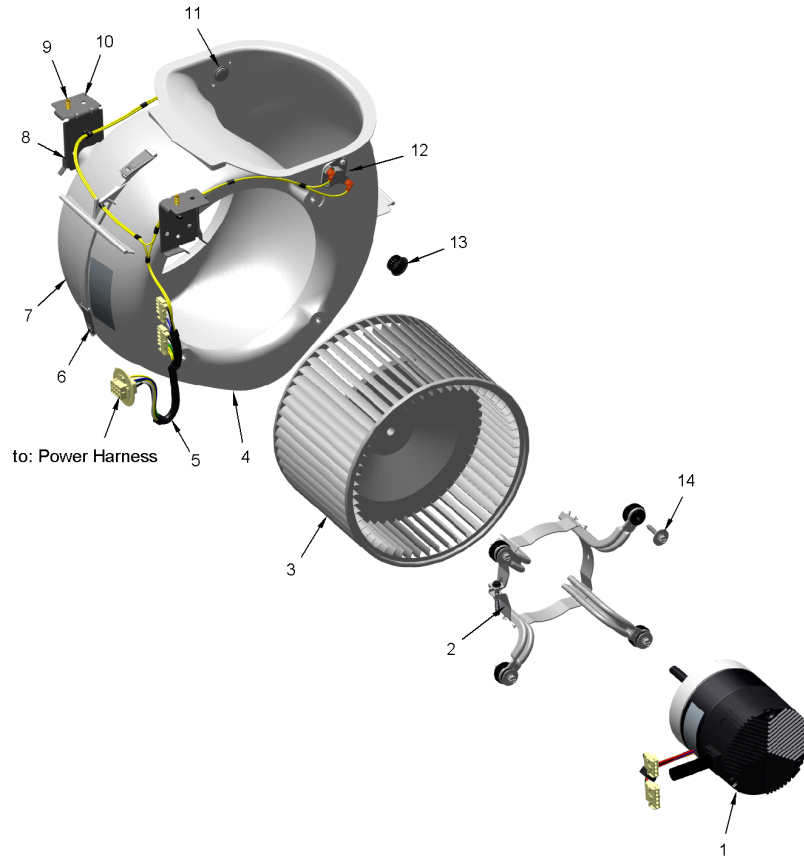

This is a typical illustration. The unit in the field may not appear exactly as shown.

Part No.	Reference No.	Quantity	Description
BLW01412	*	1	BLOWER; ASSEMBLY-COMPLETE (ECM MOTOR, HOUSING, WHEEL, BELLY BAND, REVERSE FLOW SWITCHES)
MOT16957	1	1	MOTOR; VARIABLE SPEED, 3/4 HP, AC120V, 1200 RPM
BLT01015	2	1	BOLT; BELLY BAND, 1/4-20 UNC-2B, 3/8 HEX WASHER HEAD
BND00917	2	1	BAND; BELLY BAND ASSEMBLY, INCLUDES BAND, MOTOR LEGS, MOUNTING HARDWARE
WHL03316	3	1	WHEEL; BLOWER, 11.93 OD DIA, 10.68 WIDTH, 0.50 IN BORE, CW
HUS04194	4	1	HOUSING; BLOWER, MOLDED HALF, RIGHT SIDE, 18.24 X 15.37 X 8.92
WIR08824	5	1	WIRE; HARNESS, 12-PIN-ECM MOTOR (BLU,WHT,BLK,GRN,YEL WIRES)
CLP01123	6	4	CLIP; CLEAT-BLOWER
HUS04195	7	1	HOUSING; BLOWER, MOLDED HALF, LEFT SIDE, 18.24 X 15.37 X 8.79
SCR02471	8	1	SCREW; 1/4-20 UNC-2B, 3/8 HEX WASHER HEAD
SCR01011	9	2	SCREW; 1/4-20 C HXW 5/8 S N
BRK04573	10	2	BRACKET; BLOWER DECK MOUNT, 3.78 X 2.51 X 2.19
SWT03982	11	1	SWITCH; REVERSE FLOW, OPEN AT 105F, CLOSE AT 95F
SWT01649	12	1	SWITCH; REVERSE AIRFLOW, OPEN 105F, CLOSE 95F, 120/240V, 1/4QC TERM
PLU01270	13	1	PLUG; 6/6 BLACK NYLON, 1.0 MTG HOLE SIZE
SCR02112	14	4	SCREW; ASSEMBLY-MOTOR MOUNT

BURNER

75011113

RP
A

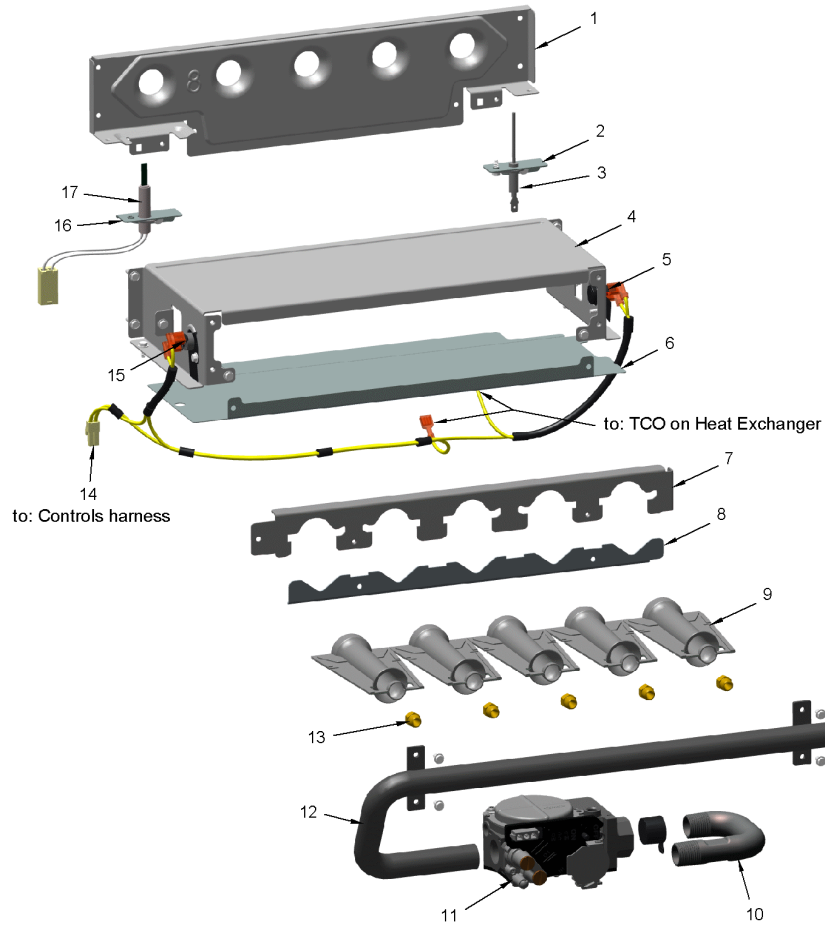

This is a typical illustration. The unit in the field may not appear exactly as shown.

Part No.	Reference No.	Quantity	Description
75011113_S9V2UP1_191265~P	*		BURNER PARTS LIST

BURNER

75011113

RP
A

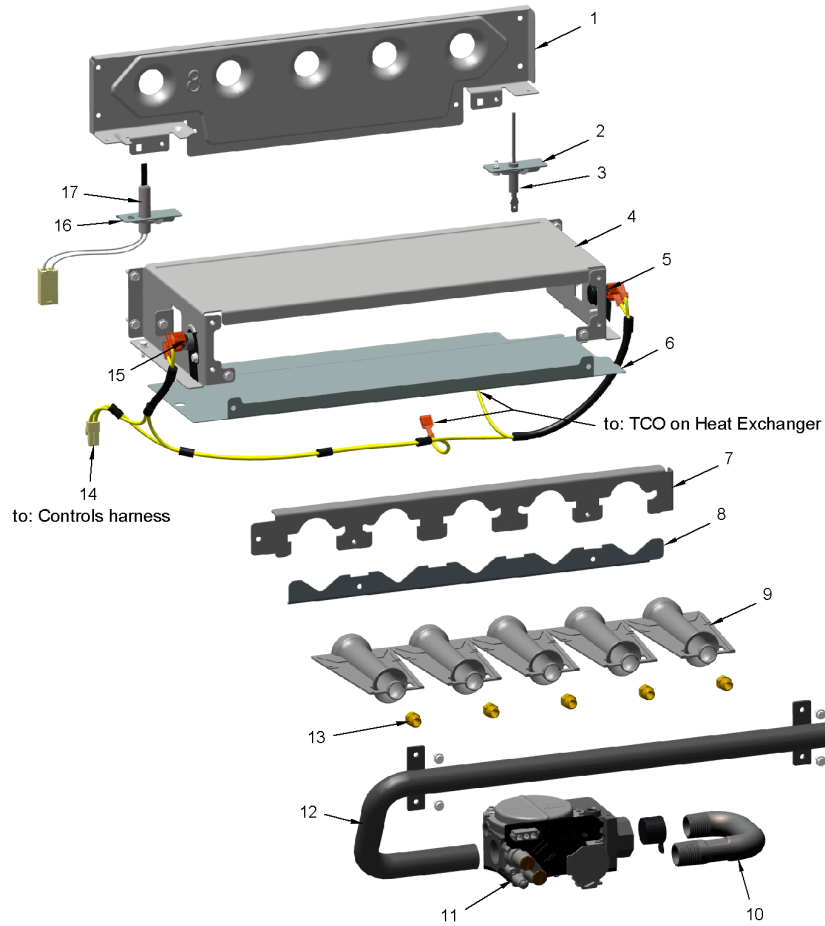

This is a typical illustration. The unit in the field may not appear exactly as shown.

Part No.	Reference No.	Quantity	Description
BRK04578	1	1	BRACKET; 5 BURNER FLAME SHAPER, 15.24 X 3.47
BRK04581	2	1	BRACKET; FLAME SENSOR, 2.063 X 0.875 X 0.456
SEN02400	3	1	SENSOR; FLAME, NIKROTHAL 80 ELECTRODE, FOR NATURAL GAS
BOX02754	4	1	BOX; BURNER, 5.74 X 15.33 X 2.63
SWT03968	5	1	SWITCH; FLAME ROLLOUT, 190F OPEN, 5.8 FLA, 34.8 LRA AT 120 VAC, 24 VAC, MAN RESET 100F, AUTO RESET -31F, FIXED TEMP THERMOSTAT AND NON-ADJ
PLT05661	6	1	PLATE; 5 BURNER, 15.33 X 5.61
HLD00628	7	1	HOLDER; 5 BURNER, 14.875 X 1.531
CMP01468	8	1	CLAMP; BURNER-5
BNR01233	9	5	BURNER; 0.50 ID INSHOT BURNER, NATURAL GAS, STAINLESS STEEL, 2.75 X 4.50
PIP02095	10	1	PIPE; U-BEND, STEEL, 1/2-14 NPT, 3.42 X 2.00
VAL09030	11	1	VALVE; GAS, NON DIRECT VENT 2 STAGE, 1/2-14 NPT, 24V, 50/60 HZ, "J" SERIES
MFD01408	12	1	MANIFOLD; 5 HOLE
ORF01427	13	5	ORIFICE; SPUD, DRILL #45, BRASS
WIR07901	14	1	WIRE; HARNESS, 5-6 BURNERS (18 AWG YEL WIRES)
SWT03967	15	1	SWITCH; FLAME ROLLOUT, 190F OPEN, 5.8 FLA, 34.8 LRA AT 120 VAC, 24 VAC, MAN RESET 100F, AUTO RESET -31F, FIXED TEMP THERMOSTAT AND NON-ADJ
BRK04580	16	1	BRACKET; IGNITER, 2.063 X 0.875 X 0.456
IGN00152	17	1	MIN=12/12 IGNITER; SILICON-NITRIDE, 120V, INCLUDES BRACKET AND SCREWS

INDUCER & VENTING

75011115

REV.
A

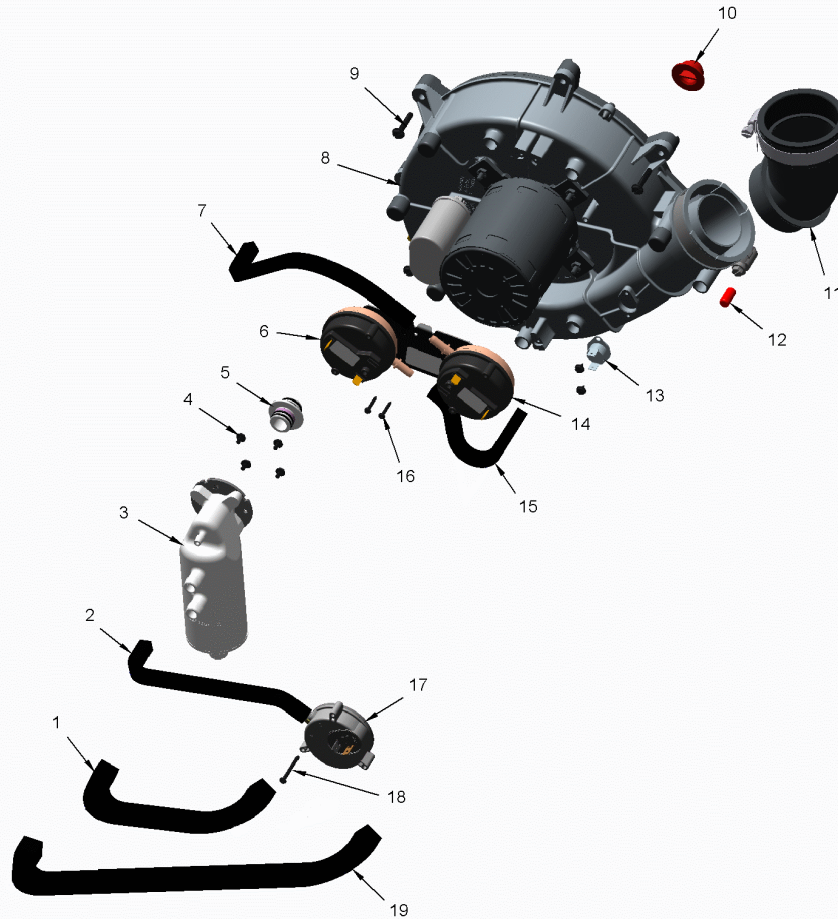

This is a typical illustration. The unit in the field may not appear exactly as shown.

Parts List Number :75011112#S9V2UP1

Model Number :S9V2C100U4PSBBB

Part No.	Reference No.	Quantity	Description
75011115_S9V2UP1_191268~P	*		INDUCER & VENTING PARTS LIST

INDUCER & VENTING

75011115

REV.
A

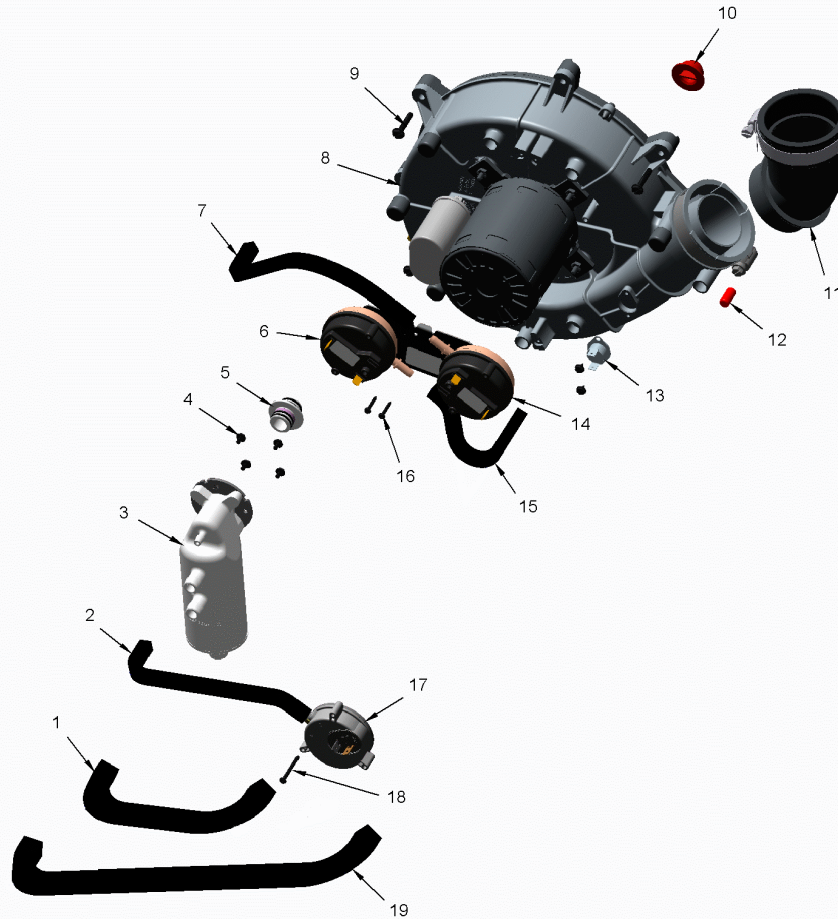

This is a typical illustration. The unit in the field may not appear exactly as shown.

Part No.	Reference No.	Quantity	Description
HSE01890	1	1	HOSE; CONDENSATE, BLACK EPDM, 10.00 L, 0.475 ID
HSE01883	2	1	HOSE; PRESSURE SWITCH, BLACK EPDM RUBBER, 0.225 ID X 19.50 L
SEP00271	3	1	SEPARATOR; ASSEMBLY-UPFLOW, INCLUDES TRAP, ADAPTERS, O-RINGS AND SCREWS
SCR02521	4	6	SCREW; 6-32 X 1/4, 1/4 HX WASHER HEAD, SLOTTED, STEEL
ADP01426	5	1	ADAPTER; PVC PLASTIC, 0.718 ID, 1.20 ID
RNG02421	5	4	RING; O-RING, 0.614 ID, EPDM RUBBER
SWT03924	6	1	SWITCH; PRESSURE, SPDT, 28VA PILOT DUTY AT 24 VAC, 125VA PILOT DUTY AT 120VAC, SNAP ACTING CONTACTS, OPR TEMP RANGE: -40 TO 190F, 0.20 DEG W.C.
HSE01884	7	1	HOSE; HIGH PRESSURE, BLACK EPDM RUBBER, 0.225 ID X 12.00 L
BLW01401	8	1	BLOWER; INDUCER, 2 STAGE, 115V, 60 HZ, 3300/2345 RPM, 5 MFD CPT AT 370 VAC, INCLUDES GASKET & SCREWS
SCR02472	9	3	SCREW; 10-32 MACHINE SCREW, 5/16 SLOTTED HEX WASHER
PLU01271	10	1	PLUG; CONDENSATE, 0.77 OD X 0.50 ID
ELL01525	11	1	ELBOW; BLACK, WITH BOOT AND CLAMP
CAP01301	12	1	CAP; PRESSURE, BLACK VINYL, 0.25 ID X 0.625 L
SWT03927	13	1	SWITCH; BLOWER INDUCER LIMIT SWITCH, 155F OPEN, 95F CLOSE
SWT03992	14	1	SWITCH; PRESSURE, SPST, 28VA PILOT DUTY AT 24 VAC, 125VA PILOT DUTY AT 125VAC, SNAP ACTING CONTACTS, OPERATING TEMP RANGE: -40 TO 190F, .70 DEG W.C.
HSE01885	15	1	HOSE; PRESSURE, 0.225 ID X 7.0 L, PS1
SCR02512	16	2	SCREW; 4-24 X 1/2, 3/16 HX WASHER HEAD, #1 PHILLIPS, TYPE AB, CLEAR ZINC PLATE
SWT03926	17	1	SWITCH; CONDENSATE, POS PRESSURE, SPST, 28VA PILOT DUTY AT 24 VAC, 125VA PILOT DUTY AT 125VAC, SNAP ACTING CONTACTS, OPERATING TEMP RANGE: -40 TO 185F
SCR02473	18	1	SCREW; 4-24 X 1, TYPE AB, 3/16 HEX WASHER, #1 PHILLIPS
HSE01887	19	1	HOSE; BLOWER INDUCER, CONDENSATE, BLACK EPDM, 17.00 L, 0.475 ID

HEAT EXCHANGER

75011114

RP
A

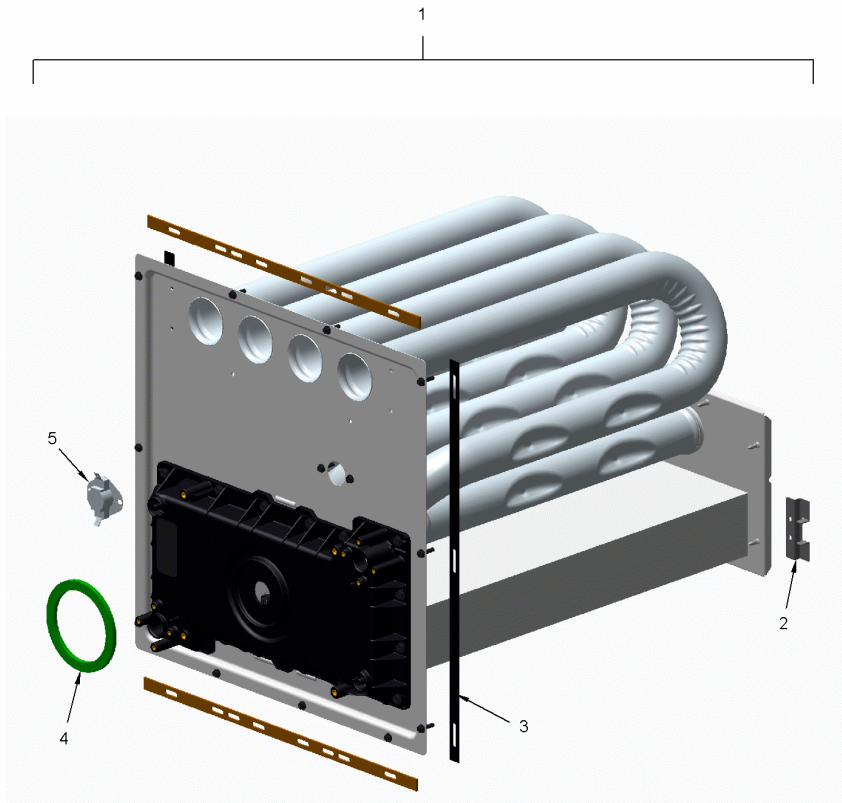

The Thermal Limit Switch (TCO) is not included with the Heat Exchanger.

This is a typical illustration. The unit in the field may not appear exactly as shown.

Part No.	Reference No.	Quantity	Description
75011114_S9V2UP1_191267~P	*		HEAT EXCHANGER PARTS LIST

HEAT EXCHANGER

75011114

RP
A

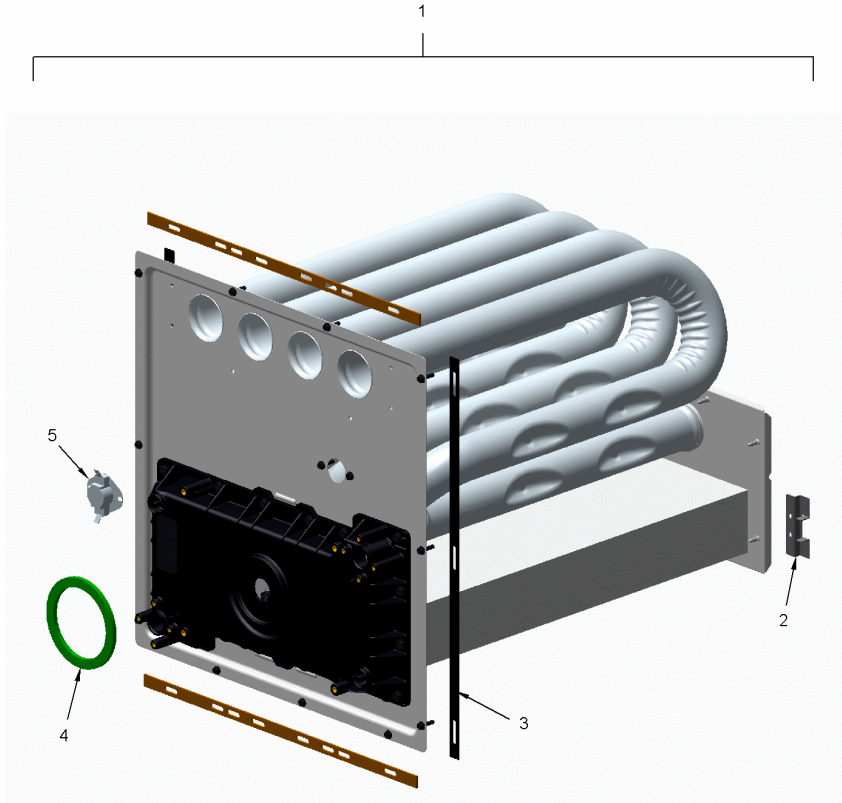

The Thermal Limit Switch (TCO) is not included with the Heat Exchanger.

This is a typical illustration. The unit in the field may not appear exactly as shown.

Part No.	Reference No.	Quantity	Description
EXC02653	1	1	EXCHANGER; HEAT, 100 MBH
BRK04574	2	2	BRACKET; HX HOT HEADER SUPPORT, 2.50 X 1.00
GKT04786	3	1	GASKET; VESTIBULE GASKETS, ONE SIZE FITS ALL - TRIM TO FIT
GKT04780	4	1	GASKET; BLOWER INDUCER, GREEN SILICONE, 3.70 OD X 2.90 ID
SWT03938	5	1	SWITCH; LIMIT, OPEN AT 135F, CLOSE AT 105F

CABINET

75010934

REV.
A

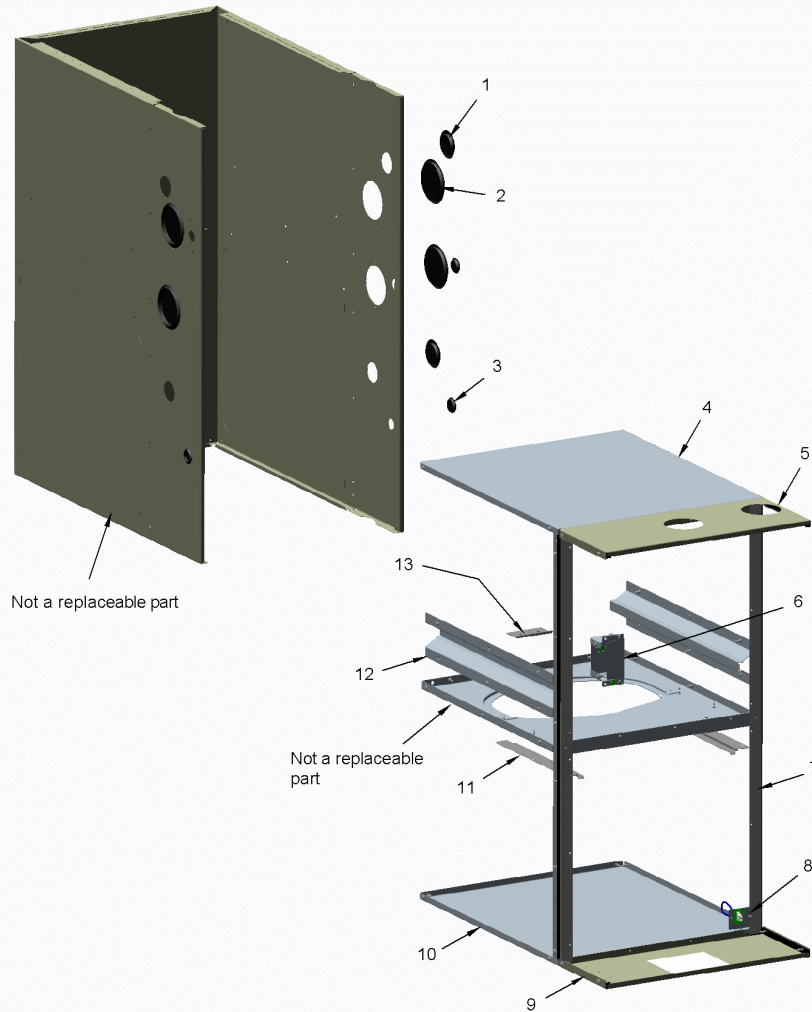

This is a typical illustration. The unit in the field may not appear exactly as shown.

Parts List Number :75011112#S9V2UP1

Model Number :S9V2C100U4PSBBB

Part No.	Reference No.	Quantity	Description
75010934_S9V2UP1_302884~P	*		CABINET PARTS LIST

CABINET

75010934

REV.
A

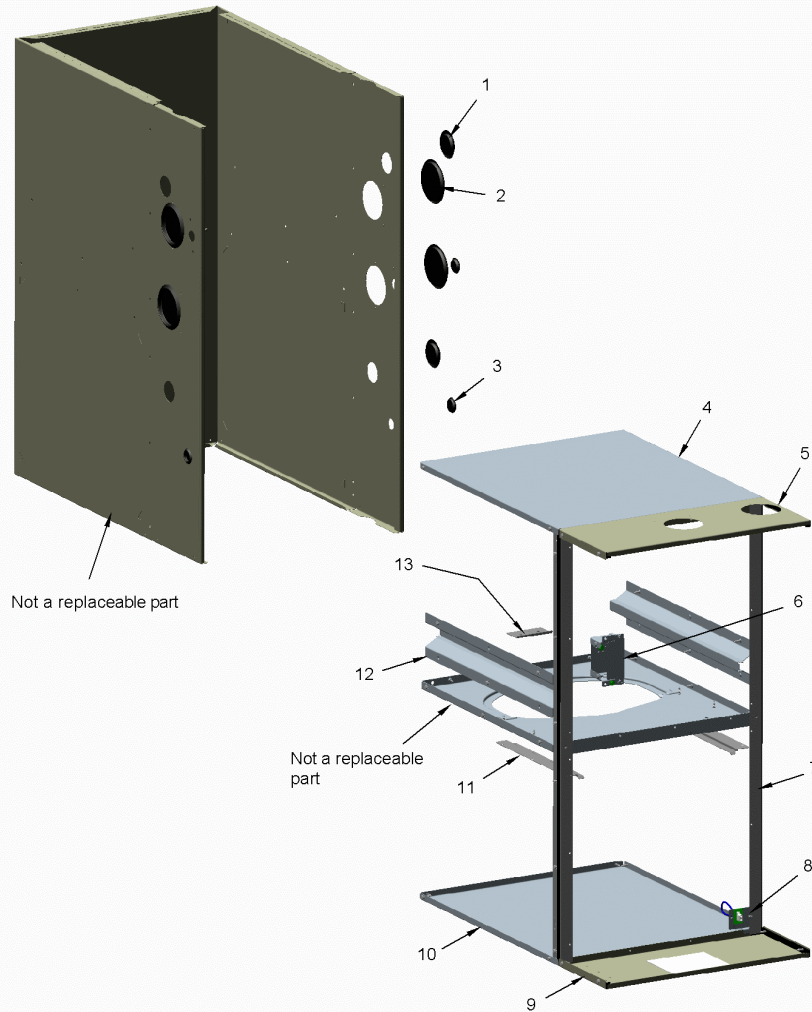

This is a typical illustration. The unit in the field may not appear exactly as shown.

Part No.	Reference No.	Quantity	Description
PAI00074	*	1	PAINT; SPRAY, SLATE GREY, FULL GLOSS(88) (SHIPPING UOM 12 OZ HAZ)
PLU01272	1	2	PLUG; GAS CONDENSATE, 1.5 INCH, BLACK PLASTIC
PLU01269	2	4	PLUG; VENTING, 3.40 OD, 2.78 ID, BLACK PLASTIC
PLU01273	3	3	PLUG; ELECTRICAL, 1.0 INCH, BLACK PLASTIC
PNL32371	4	1	PANEL; BOTTOM, 20.92 X 21.08
SUP05945	5	1	SUPPORT; CROSSMEMBER, TOP, 21.08 X 7.17
BOX02750	6	1	BOX; ASSEMBLY, JUNCTION, INCLUDES TOP, BASE, SCREWS & BUSHING
SUP05943	7	2	SUPPORT; SIDE, 33.74 X 1.07 X 1.07
WIR05160	8	1	WIRE; HARNESS, 2 PIN DF, 5 INCH BLACK WIRE
SUP05951	9	1	SUPPORT; CROSSMEMBER, BOTTOM, 21.08 X 7.17
PNL32371	10	1	PANEL; BOTTOM, 20.92 X 21.08
RAL01160	11	2	RAIL; BLOWER DECK, 10.65 X 1.64
RAL01161	12	2	RAIL; HEAT EXCHANGER, 19.15 X 3.47
RTR00985	13	1	RETAINER; BLOWER, 3.00 X 1.85

CABINET DOOR

75011003

REV.
A

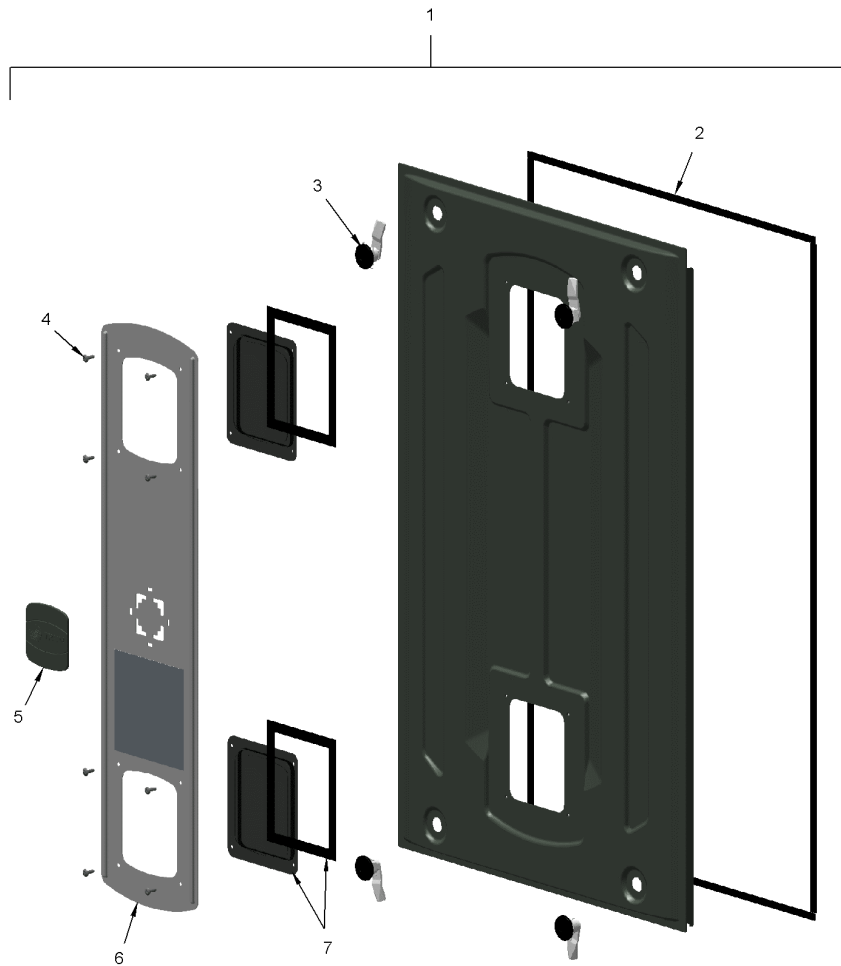

This is a typical illustration. The unit in the field may not appear exactly as shown.

FRONT DOOR PANEL

Parts List Number :75011112#S9V2UP1

Model Number :S9V2C100U4PSBBB

Part No.	Reference No.	Quantity	Description
75011003_S9V2UP1_191260~P	*		FRONT DOOR PANEL PARTS LIST

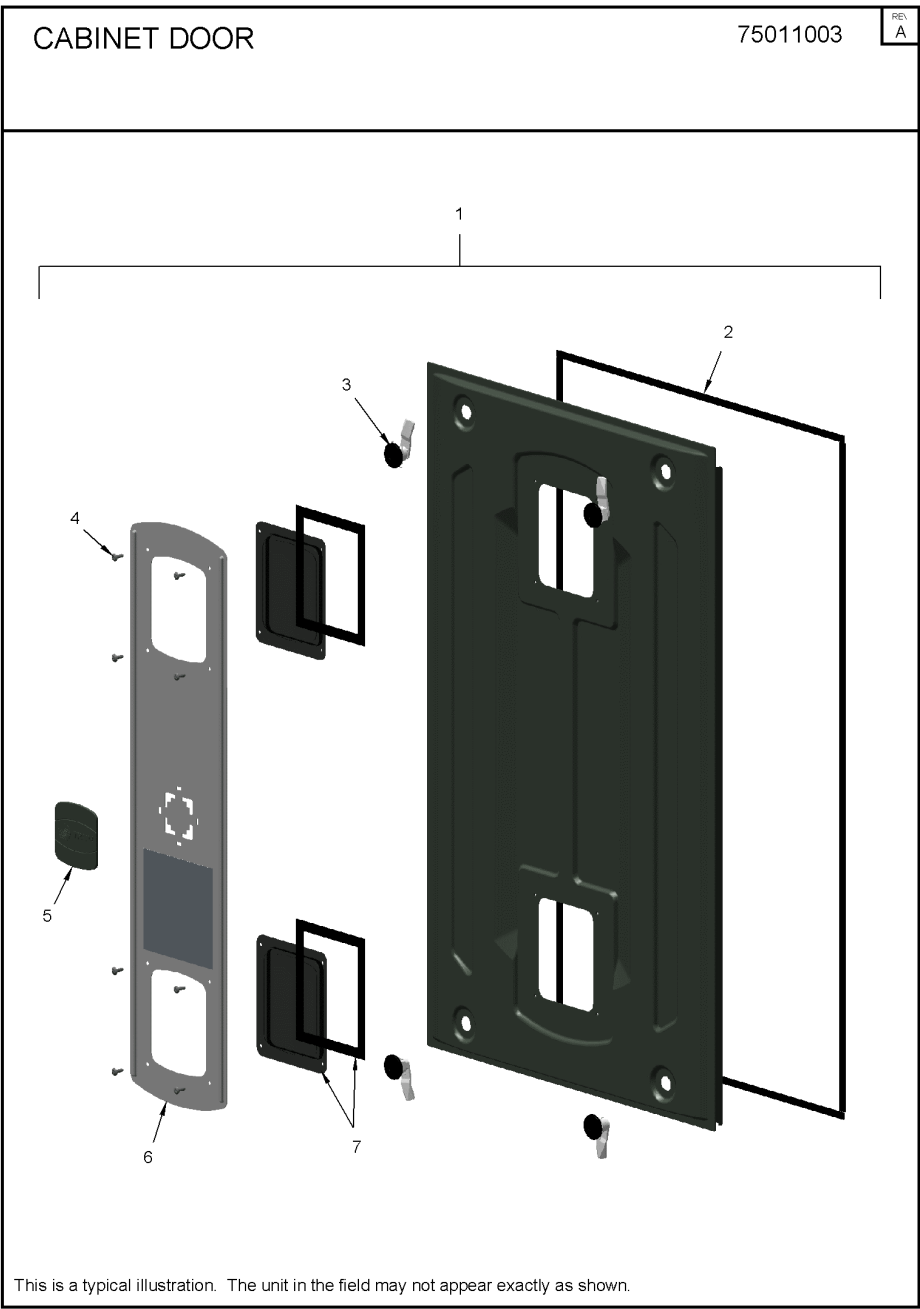

Part No.	Reference No.	Quantity	Description
PAI00248	*	1	PAINT; 12 OZ SPRAY, ANTHRACITE GRAY (SHIPPING UOM 12 OZ HAZ)
DOR04270	1	1	DOOR; ASSEMBLY, INCLUDES LATCH, SIGHT GLASS, DOOR OVERLAY, BADGES, 21 X 34
GKT04783	2	1	GASKET; DOOR GASKETS, TOP/BOTTOM X 2, SIDES X 2, ONE SIZE FITS ALL - TRIM TO FIT
LAT01007	3	4	LATCH; DOOR, STEEL, WITH GASKET
SCR02475	4	8	SCREW; 8-18, TRUSS DRIVE STYLE, TYPE B BLUNT TIP
PLT05664	5	1	PLATE; TRANE BADGE, 3.17 X 3.00
PLT05665	5	1	PLATE; AMERICAN STANDARD BADGE, 3.17 X 3.00
PLT05663	6	1	PLATE; DOOR OVERLAY, 28.77 X 7.00
GLS01089	7	1	GLASS; ASSEMBLY, INCLUDES SITE-GLASS, GASKET, 8 SCREWS

SHIP WITH PARTS

75011131

REV.
A



This is a typical illustration. The unit in the field may not appear exactly as shown.

SHIP WITH PARTS

Parts List Number :75011112#S9V2UP1

Model Number :S9V2C100U4PSBBB

Part No.	Reference No.	Quantity	Description
75011131_S9V2UP1_191271~P	*		SHIP WITH PARTS

SHIP WITH PARTS

75011131

REV.
A

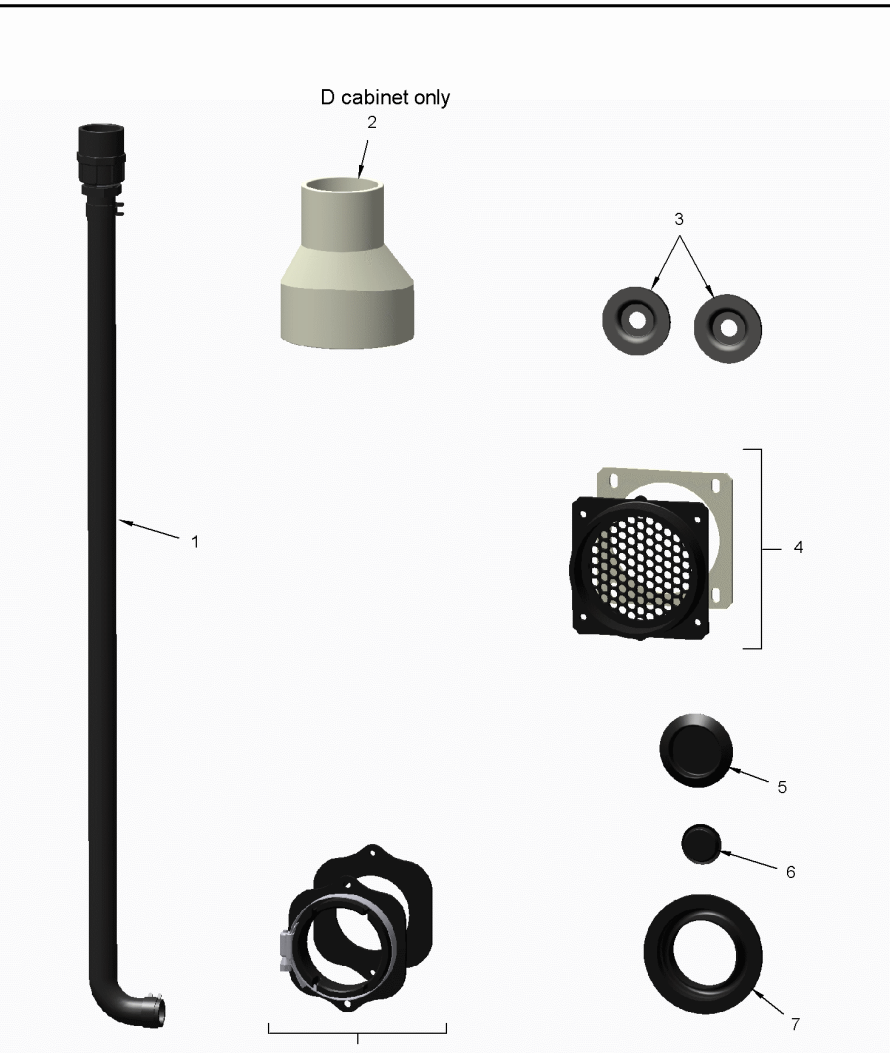

This is a typical illustration. The unit in the field may not appear exactly as shown.

Part No.	Reference No.	Quantity	Description
TUB13975	1	1	TUBE; CONDENSATE DRAIN, INCLUDES CLAMPS, ADAPTER AND COUPLING
GRM01059	3	2	GROMMET; CONDENSATE GAS, BLACK 0.99 ID X 2.0 OD
KIT17675	4	1	KIT; 2 INCH INLET ADAPTOR (ADP01052) AND GASKET (GKT03082)
PLU01272	5	1	PLUG; GAS CONDENSATE, 1.5 INCH, BLACK PLASTIC
PLU01273	6	1	PLUG; ELECTRICAL, 1.0 INCH, BLACK PLASTIC
GRM01051	7	1	GROMMET; TRAP, 3.46 OD X 2.00 ID, PVC
KIT17674	8	1	KIT; OUTLET ADAPTOR WITH CLAMP AND GASKET

MODEL NUMBER DESCRIPTION

75011116

RB
B

S-SERIES FURNACE

Example Model Number:

S 9 V 2 B 0 8 0 U 3 P S A A A
1 - - - - 5 - - - - 10 - - - - 15

Digit 1 – Level

S = Series
L = 14 ng/J Ultra-Low NOx

Digit 2 – AFUE

8 = 80%
9 = 90% or higher

Digit 3 – Blower Type

B = Builder Series (May be PSC or CTM)
P = PSC
X = CTM
V = Variable Speed

Digit 4 – Gas Valve Stages

1 = SingleStage
2 = 2 Stage
M = Modulating

Digit 5 – Cabinet Width

A = 14.5 wide
B = 17.5 wide
C = 21.0 wide
D = 24.5 wide

Digits 6,7,8 – BTU input

080 = 80,000 BTUH

Digit 9 – Poise Options

U = 3 way
D = Dedicated Downflow
M = 4 Way Poise

Digit 10 – Airflow Capacity for Cooling

2 = 2 Tons
3 = 3 Tons
4 = 4 Tons
5 = 5 Tons

Digit 11 – Inducer Type

P = PSC
X = CTM
V = Variable Speed

Digit 12 – Communicating capability

S = 24 Volt
C = Communicating System Control
T = 24 Volt, 40ng/J NOx
D = Communicating System Control,
40ng/J NOx

Digit 13 – Major Design Change

Digit 14 – Minor Design Change

Digit 15 – Service Digit Change

Part No.	Reference No.	Quantity	Description
75011116_S9V2UP1_191270~P	*		MODEL NUMBER DESCRIPTION PARTS LIST

MODEL NUMBER DESCRIPTION		75011116	RB B
S-SERIES FURNACE			
<i>Example Model Number:</i> S 9 V 2 B 0 8 0 U 3 P S A A A <small>1 - - - - 5 - - - - 10 - - - - 15</small>			
Digit 1 – Level S = Series L = 14 ng/J Ultra-Low NOx	Digit 11 – Inducer Type P = PSC X = CTM V = Variable Speed		
Digit 2 – AFUE 8 = 80% 9 = 90% or higher	Digit 12 – Communicating capability S = 24 Volt C = Communicating System Control T = 24 Volt, 40ng/J NOx D = Communicating System Control, 40ng/J NOx		
Digit 3 – Blower Type B = Builder Series (May be PSC or CTM) P = PSC X = CTM V = Variable Speed	Digit 13 – Major Design Change		
Digit 4 – Gas Valve Stages 1 = SingleStage 2 = 2 Stage M = Modulating	Digit 14 – Minor Design Change		
Digit 5 – Cabinet Width A = 14.5 wide B = 17.5 wide C = 21.0 wide D = 24.5 wide	Digit 15 – Service Digit Change		
Digits 6,7,8 – BTU input 080 = 80,000 BTUH			
Digit 9 – Poise Options U = 3 way D = Dedicated Downflow M = 4 Way Poise			
Digit 10 – Airflow Capacity for Cooling 2 = 2 Tons 3 = 3 Tons 4 = 4 Tons 5 = 5 Tons			
1 of 1			

