

S-SERIES FURNACE

75011132

REV.
A

Downflow

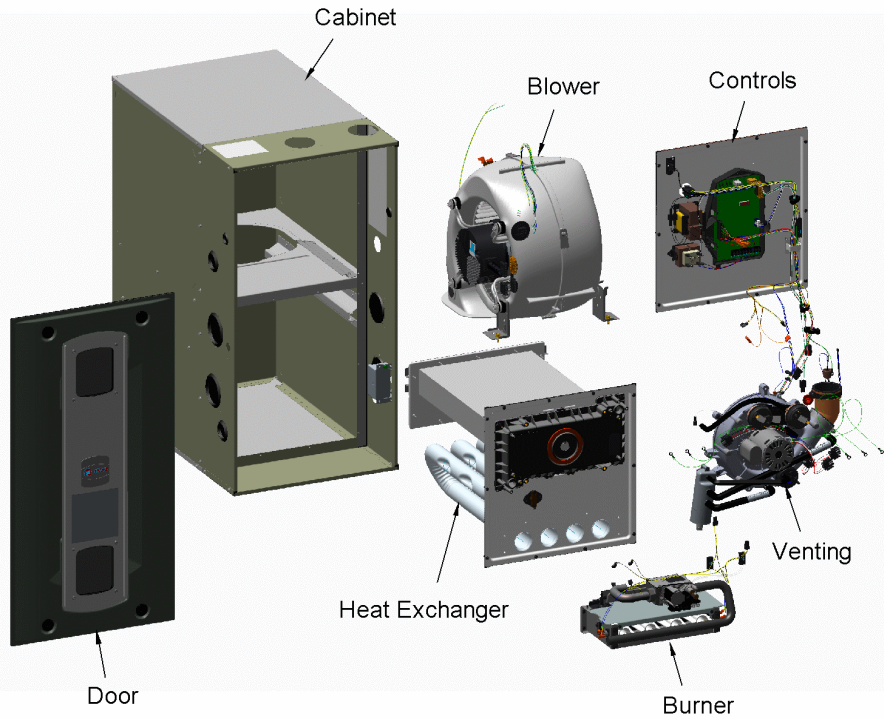

This is a typical illustration. The unit in the field may not appear exactly as shown.

Part No.	Reference No.	Quantity	Description
75011136#S9V2UP2~S	*		BLOWER
75011133#S9V2UP2~S	*		BURNER
75011134#S9V2UP2~S	*		CABINET
75011135#S9V2UP2~S	*		CONTROLS
S9V2ACCY#S9V2UP2~S	*		FIELD INSTALLED ACCESSORIES
75011003#S9V2UP2~S	*		FRONT DOOR PANEL
75011137#S9V2UP2~S	*		HEAT EXCHANGER
75011115#S9V2UP2~S	*		INDUCER & VENTING
75011116#S9V2UP2~S	*		MODEL NUMBER DESCRIPTION
75011132_S9V2UP2_147490~P	*		S-SERIES FURNACE PARTS LIST
75011131#S9V2UP2~S	*		SHIP WITH COMPONENTS

S-SERIES FURNACE

75011132

REV.
A

Downflow

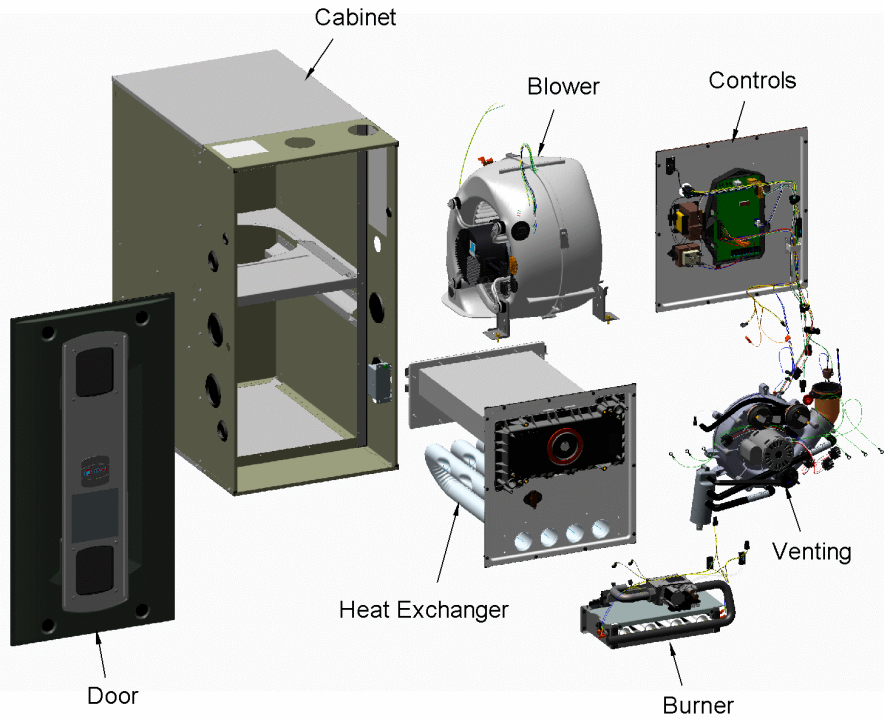

This is a typical illustration. The unit in the field may not appear exactly as shown.

CONTROLS

75011135

REV.
A

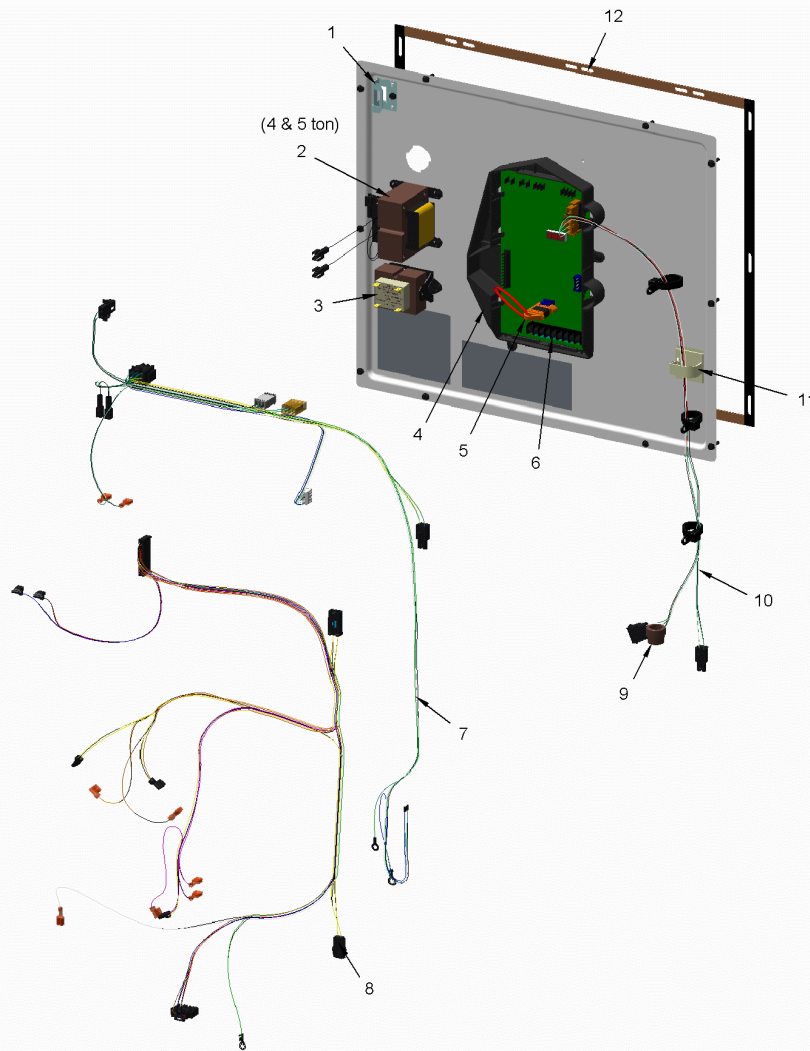

This is a typical illustration. The unit in the field may not appear exactly as shown.

CONTROLS

Parts List Number :75011132#S9V2UP2

Model Number :S9V2B080D3PSBBA

Part No.	Reference No.	Quantity	Description
75011135_S9V2UP2_249372~P	*		CONTROLS PARTS LIST

CONTROLS

75011135

REV
A

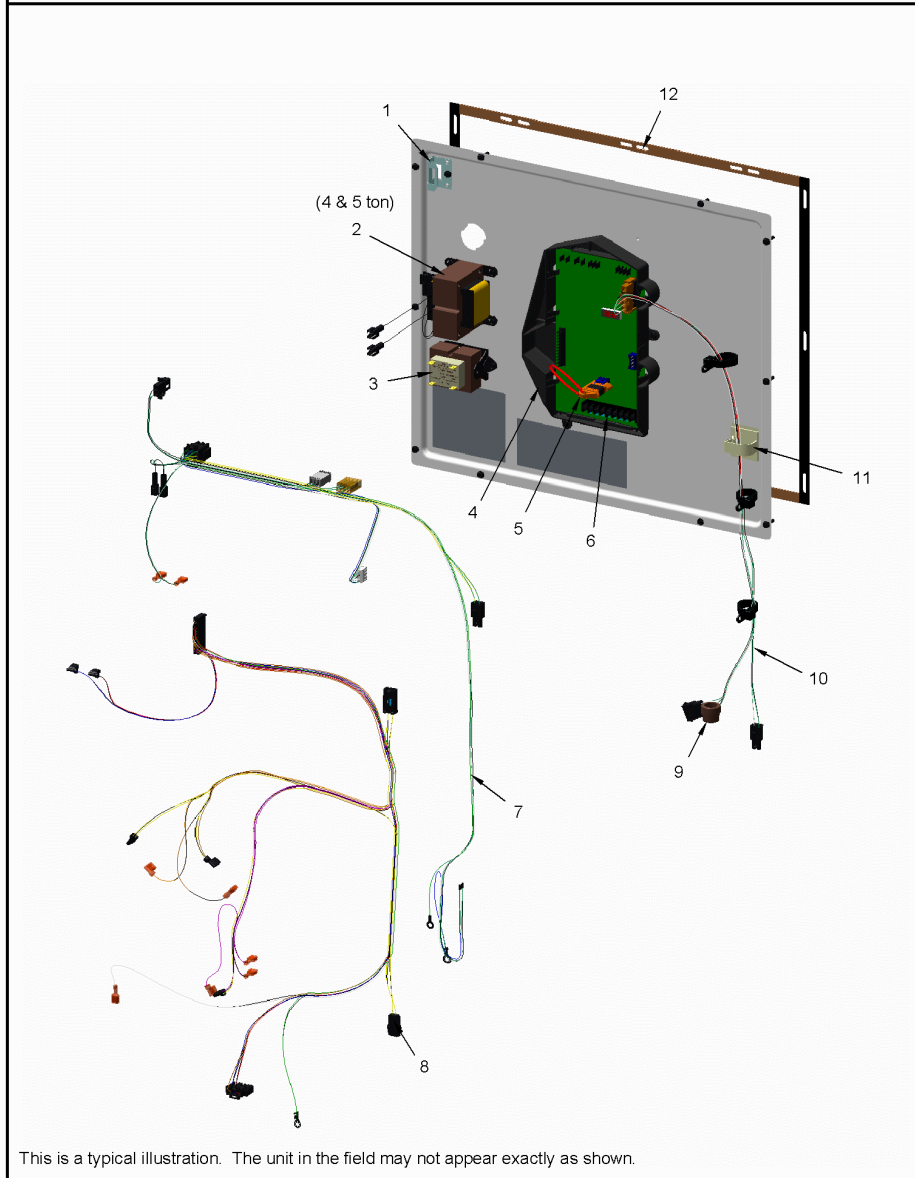

Part No.	Reference No.	Quantity	Description
TRR02736	2	1	TRANSFORMER; 115V-24V, 35VA, 60 HZ, CLASS 2
MOD01574	5	1	MODULE; TO ORDER-SEE EXT NOTE
CNT07721	6	1	CONTROL; W/ IFC, 2 STAGE FURNACE CONTROL
WIR08830	7	1	WIRE; HARNESS, POWER, DOWNFLOW (BLK, WHT, BLU, GRN/YL, GRN, YEL WIRES)
WIR07910	8	1	WIRE; HARNESS; CONTROLS, DOWNFLOW (PUR, BLU, YEL, RED, BRN, GRN, ORG, WHT WIRES)
BUS00300	9	1	BUSHING; STRAIN RELIEF
WIR07914	10	1	WIRE; HARNESS, BLOWER INDUCER/IGNITER, DOWNFLOW (BLK, RED, WHT WIRES)
MNT02457	11	1	MOUNT; WIRE HARNESS, MCLIP-BEVEL ENTRY, MOLDED, 1.49 X 1.46 X 0.89, 6/6 NYLON WITH FOAM ADHESIVE TAPE
GKT04786	12	1	GASKET; VESTIBULE GASKETS, ONE SIZE FITS ALL - TRIM TO FIT

Part No.	Reference No.	Quantity	Description
S9V2ACCY_S9V2UP2_147503~P	*		FIELD INSTALLED ACCESSORIES PARTS LIST

NO GRAPHIC AVAILABLE

75013702

REV
A

**NO
GRAPHIC
AVAILABLE**

Parts List Number :75011132#S9V2UP2

Model Number :S9V2B080D3PSBBA

Part No.	Reference No.	Quantity	Description
BAS00828	*	1	BASE; SUB ASSEMBLY (BAYBASE205)
BAYAIR30CNVENT	*	1	KIT-CONCENTRIC-VENT-CANADA
BAYLPSS400A	*	1	KIT; LP CONVERSION KIT W/ (6) STAINLESS STEEL BURNERS, SEN02662, KIT01495 & KIT07611
BAYVENTCN200B	*	1	KIT-VENT-SIDE-WALL-CANADA
FLR01603	*	1	FILTER; FRAMED FILTER KIT ASSY (BAYFLTR203) FOR REPLACEMENT FILTER ONLY USE FLR01611
KIT06444	*	1	KIT; SIDE WALL VENT ASSEMBLY (BAYVENT200B)
VNT00133	*	1	VENT; CONCENTRIC VENT KIT, (BAYAIR30AVENTAA)
BUS00300	1	1	BUSHING; STRAIN RELIEF

BLOWER

75011136

RP
A

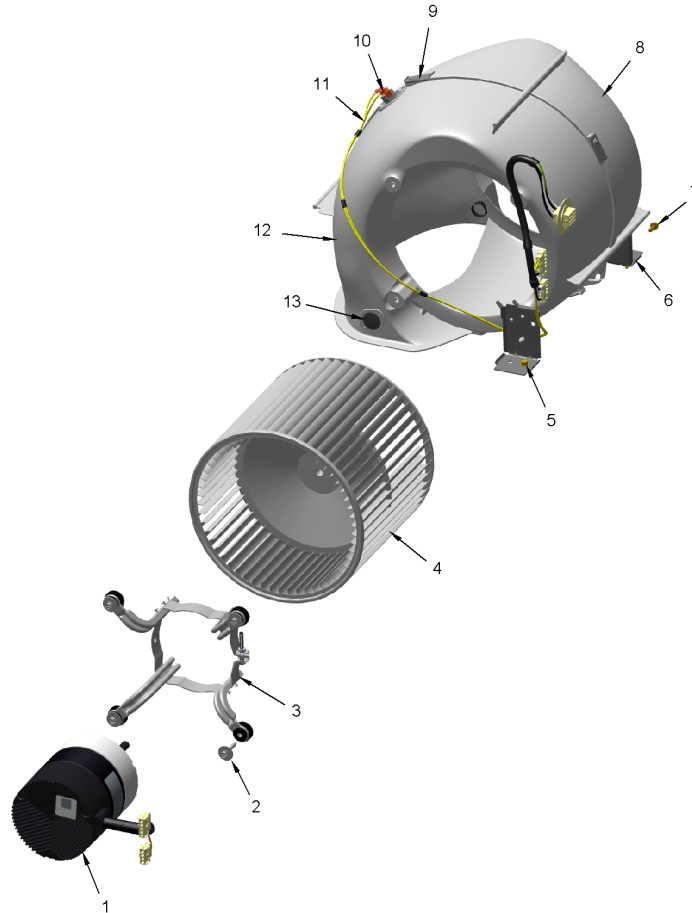

This is a typical illustration. The unit in the field may not appear exactly as shown.

Part No.	Reference No.	Quantity	Description
75011136_S9V2UP2_247679~P	*		BLOWER PARTS LIST

BLOWER

75011136

RP
A

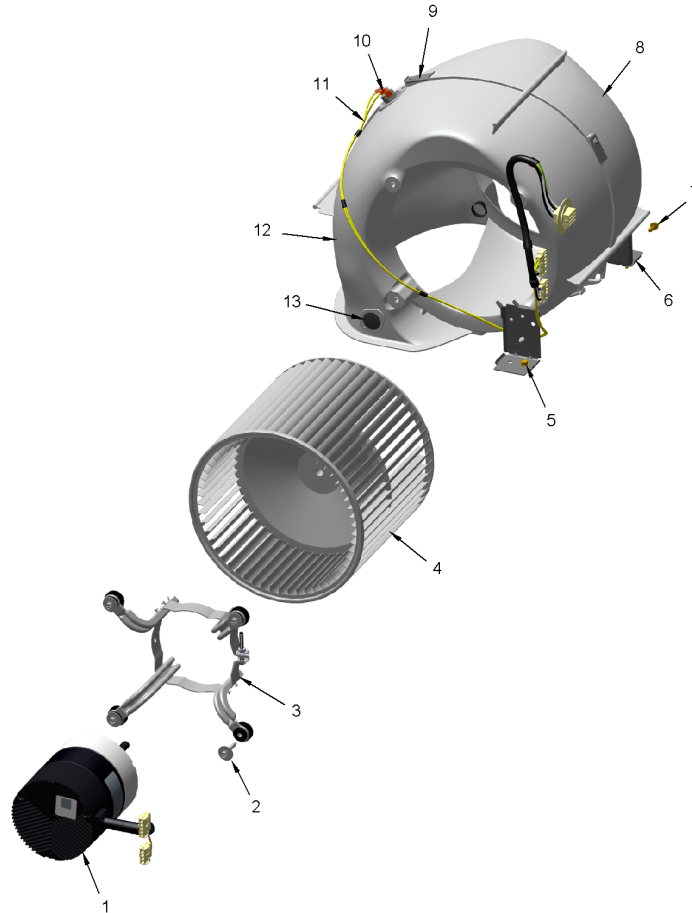

This is a typical illustration. The unit in the field may not appear exactly as shown.

Part No.	Reference No.	Quantity	Description
BLW01434	*	1	BLOWER; ASSEMBLY-COMplete (ECM MOTOR, HOUSING, WHEEL, BELLY BAND, REVERSE FLOW SWITCHES)
MOT16956	1	1	MOTOR; VARIABLE SPEED, 1/2 HP, AC120V, 1200 RPM
SCR02112	2	4	SCREW; ASSEMBLY-MOTOR MOUNT
BLT01015	3	1	BOLT; BELLY BAND, 1/4-20 UNC-2B, 3/8 HEX WASHER HEAD
BND00917	3	1	BAND; BELLY BAND ASSEMBLY, INCLUDES BAND, MOTOR LEGS, MOUNTING HARDWARE
WHL02916	4	1	WHEEL; BLOWER, 11 IN DIA, 8 IN WIDTH, 0.50 IN BORE, CW
SCR01011	5	2	SCREW; 1/4-20 C HXW 5/8 S N
BRK04572	6	2	BRACKET; BLOWER DECK MOUNT, 3.65 X 2.51 X 1.84
SCR02471	7	1	SCREW; 1/4-20 UNC-2B, 3/8 HEX WASHER HEAD
HUS04193	8	1	HOUSING; BLOWER, MOLDED HALF, LEFT SIDE, 18.00 X 15.28 X 6.79
CLP01123	9	4	CLIP; CLEAT-BLOWER
SWT03981	10	1	SWITCH; REVERSE FLOW, OPEN AT 95F, CLOSE AT 85F
WIR08825	11	1	WIRE; HARNESS, 12-PIN-ECM MOTOR (BLU,WHT,BLK,GRN,YEL WIRES)
HUS04192	12	1	HOUSING; BLOWER, MOLDED HALF, RIGHT SIDE, 18.00 X 15.28 X 6.92
PLU01270	13	2	PLUG; 6/6 BLACK NYLON, 1.0 MTG HOLE SIZE

BURNER

75011133

RP
A

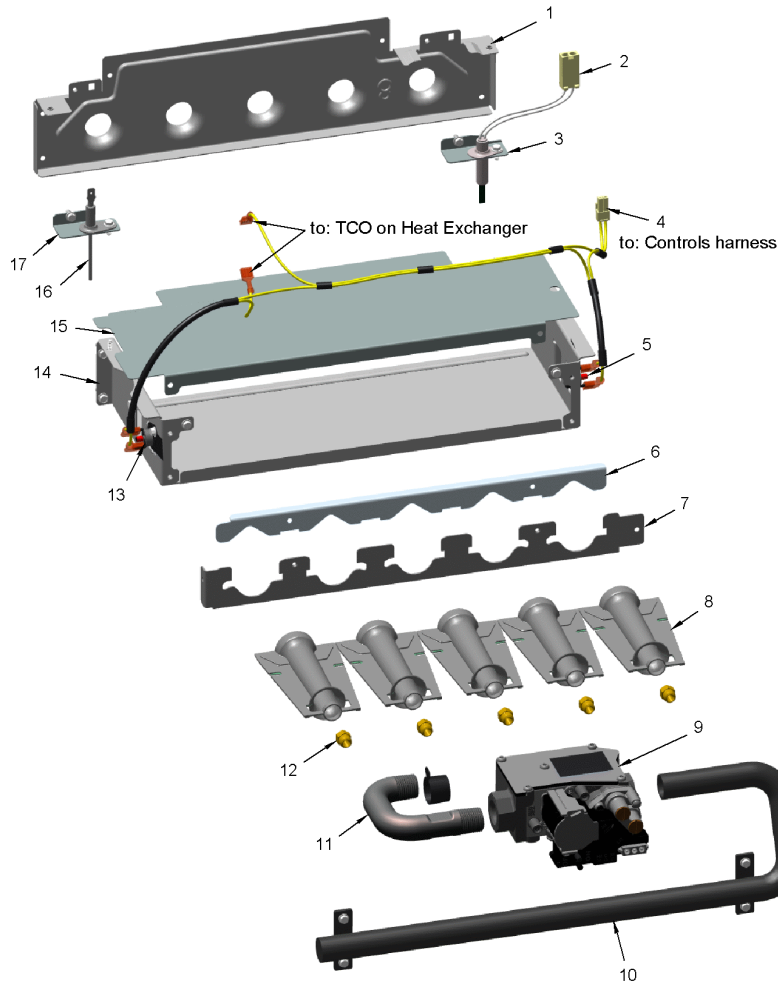

This is a typical illustration. The unit in the field may not appear exactly as shown.

Parts List Number :75011132#S9V2UP2

Model Number :S9V2B080D3PSBBA

Part No.	Reference No.	Quantity	Description
75011133_S9V2UP2_247678~P	*		BURNER PARTS LIST

BURNER

75011133

RP
A

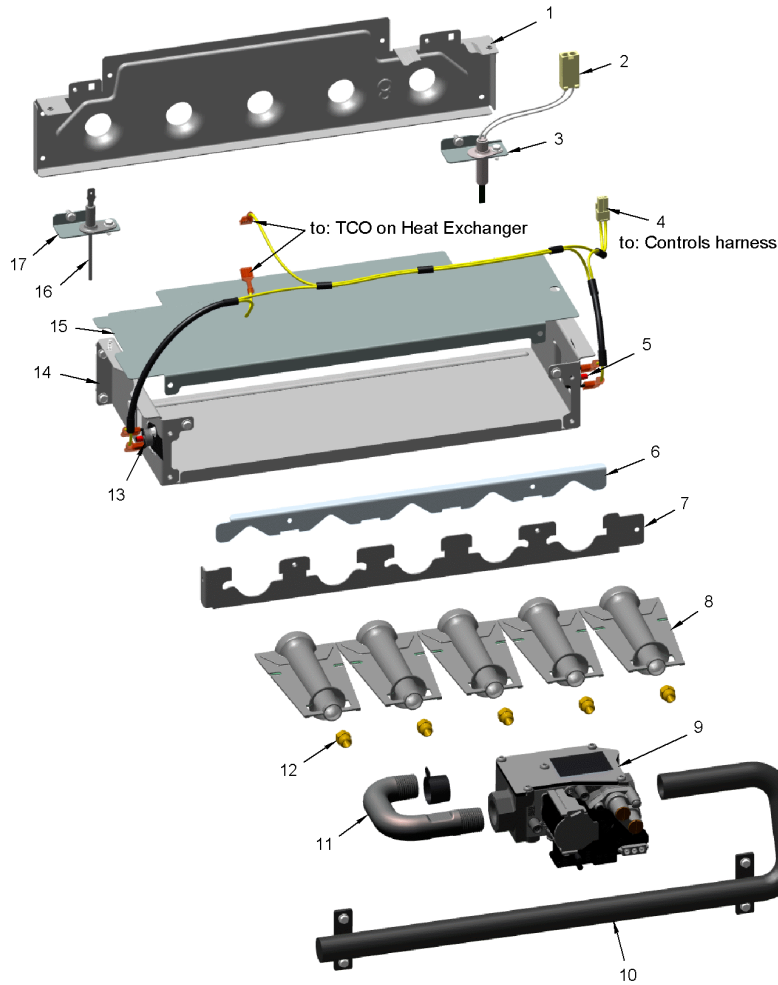

This is a typical illustration. The unit in the field may not appear exactly as shown.

Part No.	Reference No.	Quantity	Description
BRK04577	1	1	BRACKET; 4 BURNER FLAME SHAPER, 12.50 X 3.47
IGN00152	2	1	MIN=12/12 IGNITER; SILICON-NITRIDE, 120V, INCLUDES BRACKET AND SCREWS
BRK04580	3	1	BRACKET; IGNITER, 2.063 X 0.875 X 0.456
WIR07900	4	1	WIRE; HARNESS, 2-3-4 BURNERS (18 AWG YEL WIRES)
SWT03967	5	1	SWITCH; FLAME ROLLOUT, 190F OPEN, 5.8 FLA, 34.8 LRA AT 120 VAC, 24 VAC, MAN RESET 100F, AUTO RESET -31F, FIXED TEMP THERMOSTAT AND NON-ADJ
CMP01467	6	1	CLAMP; BURNER - 4
HLD00627	7	1	HOLDER; 4 BURNER, 12.125 X 1.531
BNR01233	8	4	BURNER; 0.50 ID INSHOT BURNER, NATURAL GAS, STAINLESS STEEL, 2.75 X 4.50
VAL09030	9	1	VALVE; GAS, NON DIRECT VENT 2 STAGE, 1/2-14 NPT, 24V, 50/60 HZ, "J" SERIES
MFD01407	10	1	MANIFOLD; 4 HOLE
PIP02095	11	1	PIPE; U-BEND, STEEL, 1/2-14 NPT, 3.42 X 2.00
ORF01427	12	4	ORIFICE; SPUD, DRILL #45, BRASS
SWT03968	13	1	SWITCH; FLAME ROLLOUT, 190F OPEN, 5.8 FLA, 34.8 LRA AT 120 VAC, 24 VAC, MAN RESET 100F, AUTO RESET -31F, FIXED TEMP THERMOSTAT AND NON-ADJ
BOX02753	14	1	BOX; BURNER, 5.74 X 12.58 X 2.63
PLT05660	15	1	PLATE; 4 BURNER, 12.58 X 5.61
SEN02400	16	1	SENSOR; FLAME, NIKROTHAL 80 ELECTRODE, FOR NATURAL GAS
BRK04581	17	1	BRACKET; FLAME SENSOR, 2.063 X 0.875 X 0.456

INDUCER & VENTING

75011115

REV.
A

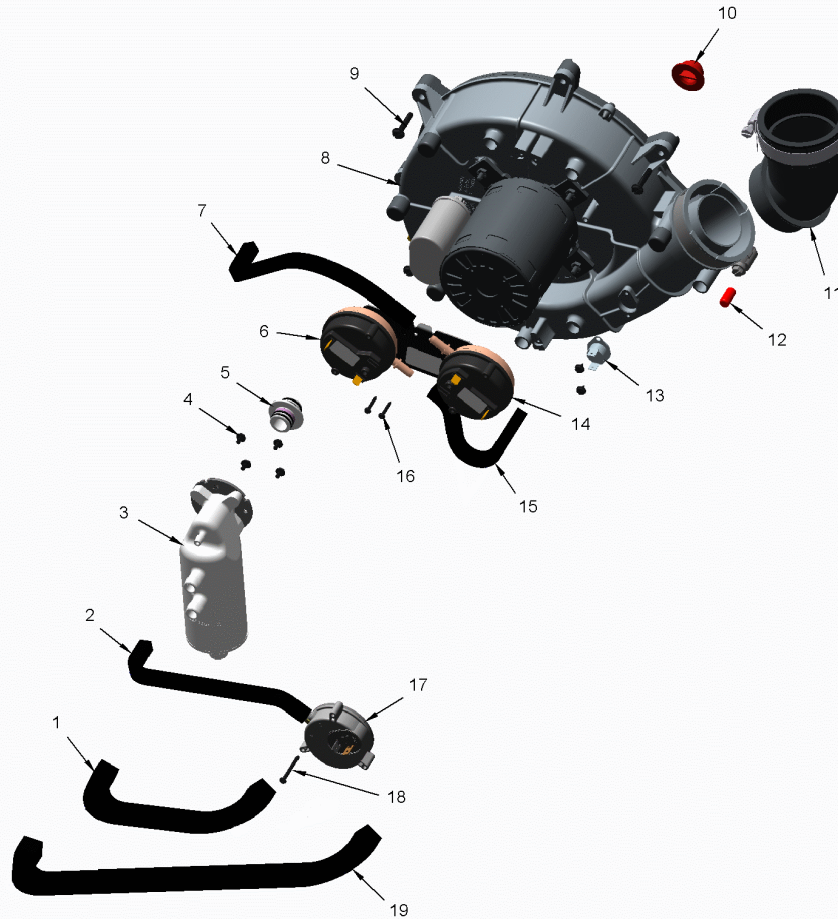

This is a typical illustration. The unit in the field may not appear exactly as shown.

Parts List Number :75011132#S9V2UP2

Model Number :S9V2B080D3PSBBA

Part No.	Reference No.	Quantity	Description
75011115_S9V2UP2_247677~P	*		INDUCER & VENTING PARTS LIST

INDUCER & VENTING

75011115

REV.
A

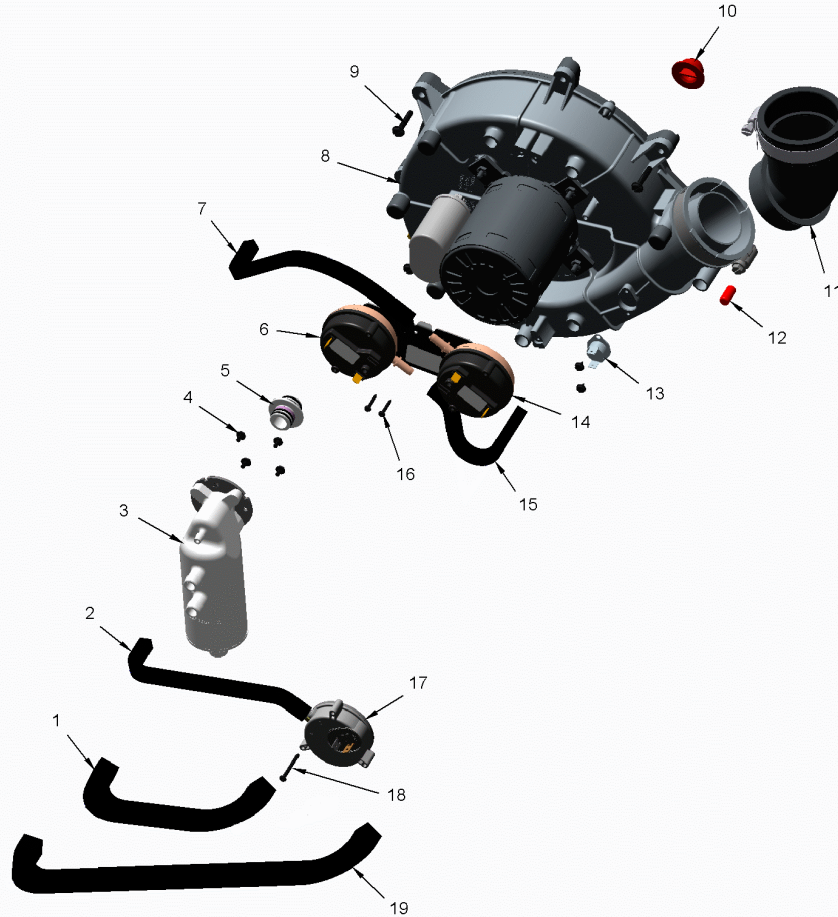

This is a typical illustration. The unit in the field may not appear exactly as shown.

Part No.	Reference No.	Quantity	Description
HSE01889	1	1	HOSE; CONDENSATE, BLACK EPDM, 9.00 L, 0.475 ID
HSE01883	2	1	HOSE; PRESSURE SWITCH, BLACK EPDM RUBBER, 0.225 ID X 19.50 L
SEP00285	3	1	SEPARATOR; ASSEMBLY-DOWNFLOW, INCLUDES TRAP, ADAPTERS, O-RINGS AND SCREWS
SCR02521	4	6	SCREW; 6-32 X 1/4, 1/4 HX WASHER HEAD, SLOTTED, STEEL
ADP01426	5	1	ADAPTER; PVC PLASTIC, 0.718 ID, 1.20 ID
RNG02421	5	4	RING; O-RING, 0.614 ID, EPDM RUBBER
SWT03924	6	1	SWITCH; PRESSURE, SPDT, 28VA PILOT DUTY AT 24 VAC, 125VA PILOT DUTY AT 120VAC, SNAP ACTING CONTACTS, OPR TEMP RANGE: -40 TO 190F, 0.20 DEG W.C.
HSE01884	7	1	HOSE; HIGH PRESSURE, BLACK EPDM RUBBER, 0.225 ID X 12.00 L
BLW01401	8	1	BLOWER; INDUCER, 2 STAGE, 115V, 60 HZ, 3300/2345 RPM, 5 MFD CPT AT 370 VAC, INCLUDES GASKET & SCREWS
SCR02472	9	3	SCREW; 10-32 MACHINE SCREW, 5/16 SLOTTED HEX WASHER
PLU01271	10	1	PLUG; CONDENSATE, 0.77 OD X 0.50 ID
ELL01524	11	1	ELBOW; BLACK, WITH BOOT AND CLAMP
CAP01301	12	1	CAP; PRESSURE, BLACK VINYL, 0.25 ID X 0.625 L
SWT03927	13	1	SWITCH; BLOWER INDUCER LIMIT SWITCH, 155F OPEN, 95F CLOSE
SWT03971	14	1	SWITCH; PRESSURE, SPST, 28VA PILOT DUTY AT 24 VAC, 125VA PILOT DUTY AT 125VAC, SNAP ACTING CONTACTS, OPR TEMP RANGE: -40 TO 190F, 1.00 DEG W.C.
HSE01885	15	1	HOSE; PRESSURE, 0.225 ID X 7.0 L, PS1
SCR02512	16	2	SCREW; 4-24 X 1/2, 3/16 HX WASHER HEAD, #1 PHILLIPS, TYPE AB, CLEAR ZINC PLATE
SWT03926	17	1	SWITCH; CONDENSATE, POS PRESSURE, SPST, 28VA PILOT DUTY AT 24 VAC, 125VA PILOT DUTY AT 125VAC, SNAP ACTING CONTACTS, OPERATING TEMP RANGE: -40 TO 185F
SCR02473	18	1	SCREW; 4-24 X 1, TYPE AB, 3/16 HEX WASHER, #1 PHILLIPS
HSE01886	19	1	HOSE; BLOWER INDUCER, CONDENSATE, BLACK EPDM, 15.00 L, 0.475 ID

HEAT EXCHANGER

75011137

RP
A

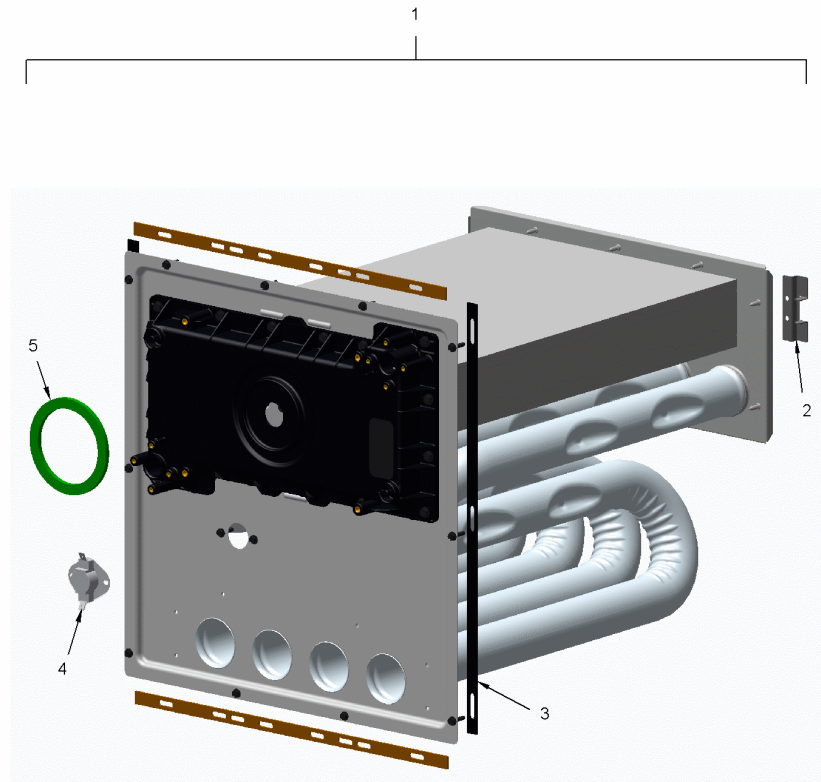

The Thermal Limit Switch (TCO) is not included with the Heat Exchanger.

This is a typical illustration. The unit in the field may not appear exactly as shown.

Part No.	Reference No.	Quantity	Description
75011137_S9V2UP2_247680~P	*		HEAT EXCHANGER PARTS LIST

HEAT EXCHANGER

75011137

RP
A

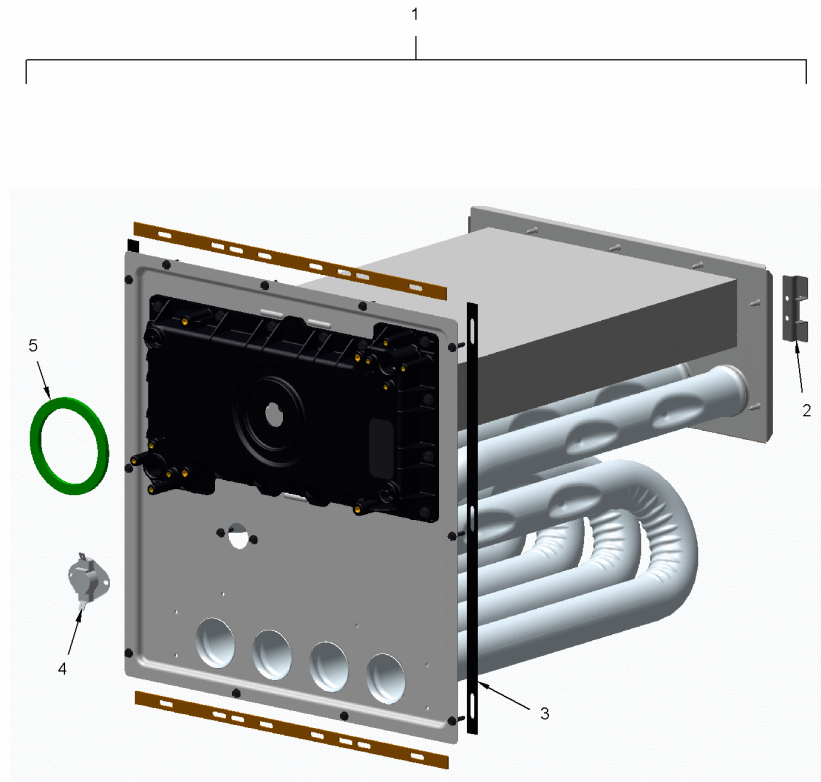

The Thermal Limit Switch (TCO) is not included with the Heat Exchanger.

This is a typical illustration. The unit in the field may not appear exactly as shown.

Part No.	Reference No.	Quantity	Description
EXC02702	1	1	EXCHANGER; HEAT, 80 MBH
BRK04574	2	2	BRACKET; HX HOT HEADER SUPPORT, 2.50 X 1.00
GKT04786	3	1	GASKET; VESTIBULE GASKETS, ONE SIZE FITS ALL - TRIM TO FIT
SWT03938	4	1	SWITCH; LIMIT, OPEN AT 135F, CLOSE AT 105F
GKT04780	5	1	GASKET; BLOWER INDUCER, GREEN SILICONE, 3.70 OD X 2.90 ID

CABINET

75011134

REV.
A

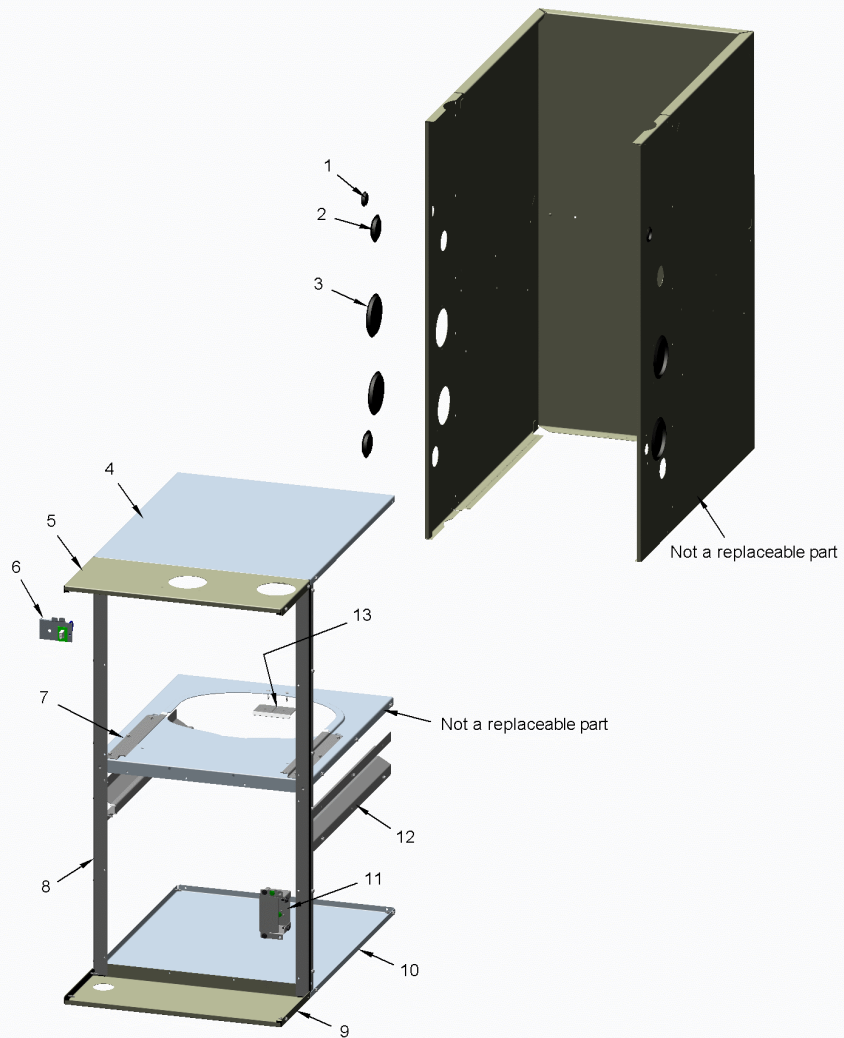

This is a typical illustration. The unit in the field may not appear exactly as shown.

Parts List Number :75011132#S9V2UP2

Model Number :S9V2B080D3PSBBA

Part No.	Reference No.	Quantity	Description
75011134_S9V2UP2_147496~P	*		CABINET PARTS LIST

CABINET

75011134

REV.
A

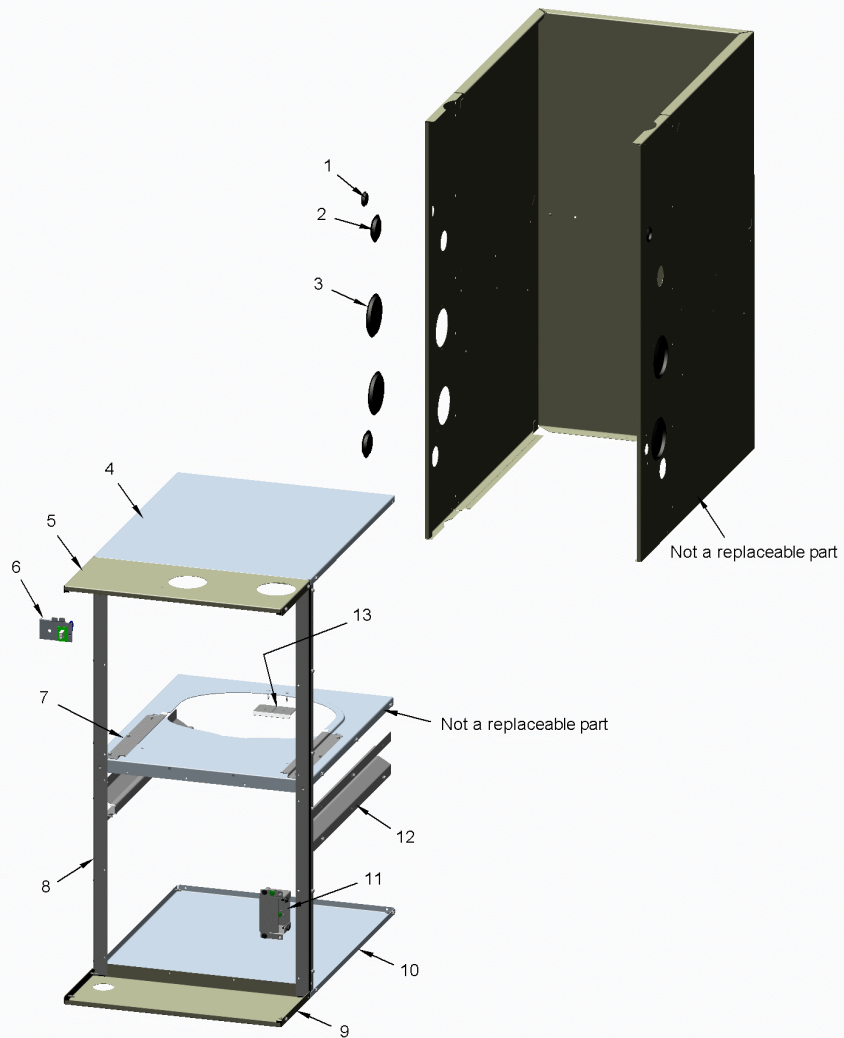

This is a typical illustration. The unit in the field may not appear exactly as shown.

Part No.	Reference No.	Quantity	Description
PAI00074	*	1	PAINT; SPRAY, SLATE GREY, FULL GLOSS(88) (SHIPPING UOM 12 OZ HAZ)
PLU01273	1	3	PLUG; ELECTRICAL, 1.0 INCH, BLACK PLASTIC
PLU01272	2	2	PLUG; GAS CONDENSATE, 1.5 INCH, BLACK PLASTIC
PLU01269	3	4	PLUG; VENTING, 3.40 OD, 2.78 ID, BLACK PLASTIC
PNL32370	4	1	PANEL; BOTTOM, 20.92 X 17.58
SUP05953	5	1	SUPPORT; CROSSMEMBER, BOTTOM, 17.58 X 7.17
BRK04571	6	1	BRACKET; ASSEMBLY. INCLUDES BOTH DOOR SWITCH BRACKETS AND 2 PIN WIRE HARNESS
WIR05160	6	1	WIRE; HARNESS, 2 PIN DF, 5 INCH BLACK WIRE
RAL01160	7	2	RAIL; BLOWER DECK, 10.65 X 1.64
SUP05943	8	2	SUPPORT; SIDE, 33.74 X 1.07 X 1.07
SUP05947	9	1	SUPPORT; CROSSMEMBER, TOP, 17.58 X 7.17
PNL32370	10	1	PANEL; BOTTOM, 20.92 X 17.58
BOX02750	11	1	BOX; ASSEMBLY, JUNCTION, INCLUDES TOP, BASE, SCREWS & BUSHING
RAL01161	12	2	RAIL; HEAT EXCHANGER, 19.15 X 3.47
RTR00985	13	1	RETAINER; BLOWER, 3.00 X 1.85

CABINET DOOR

75011003

REV.
A

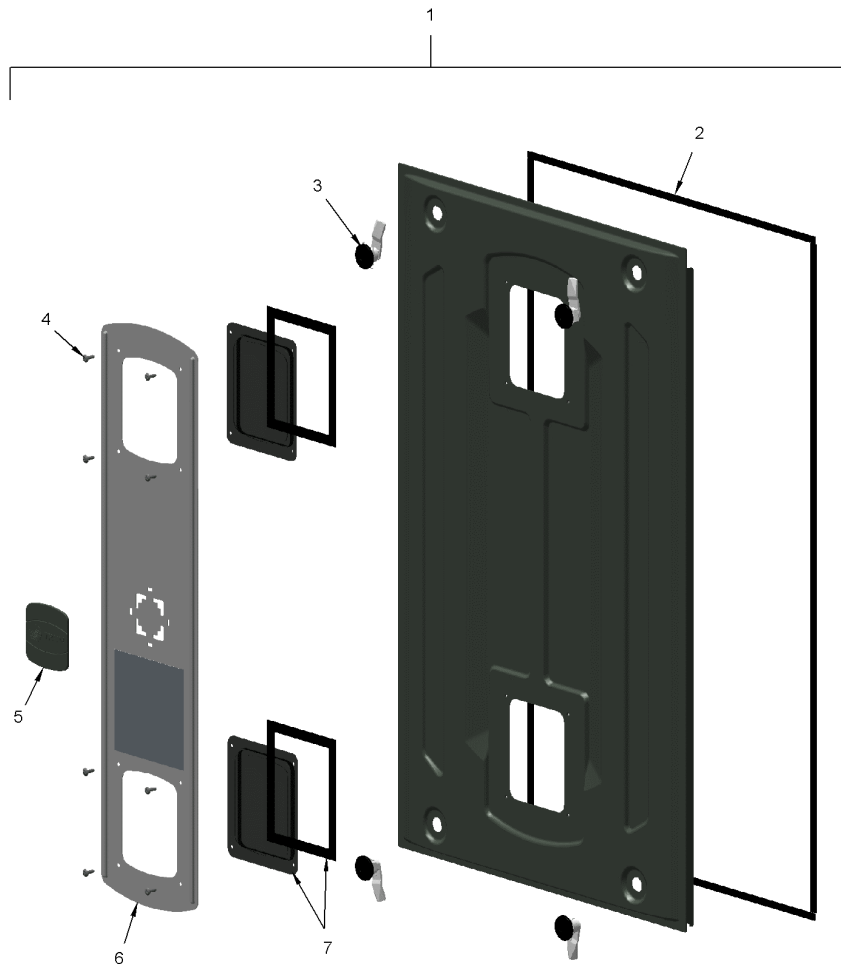

This is a typical illustration. The unit in the field may not appear exactly as shown.

Part No.	Reference No.	Quantity	Description
75011003_S9V2UP2_147491~P	*		FRONT DOOR PANEL PARTS LIST

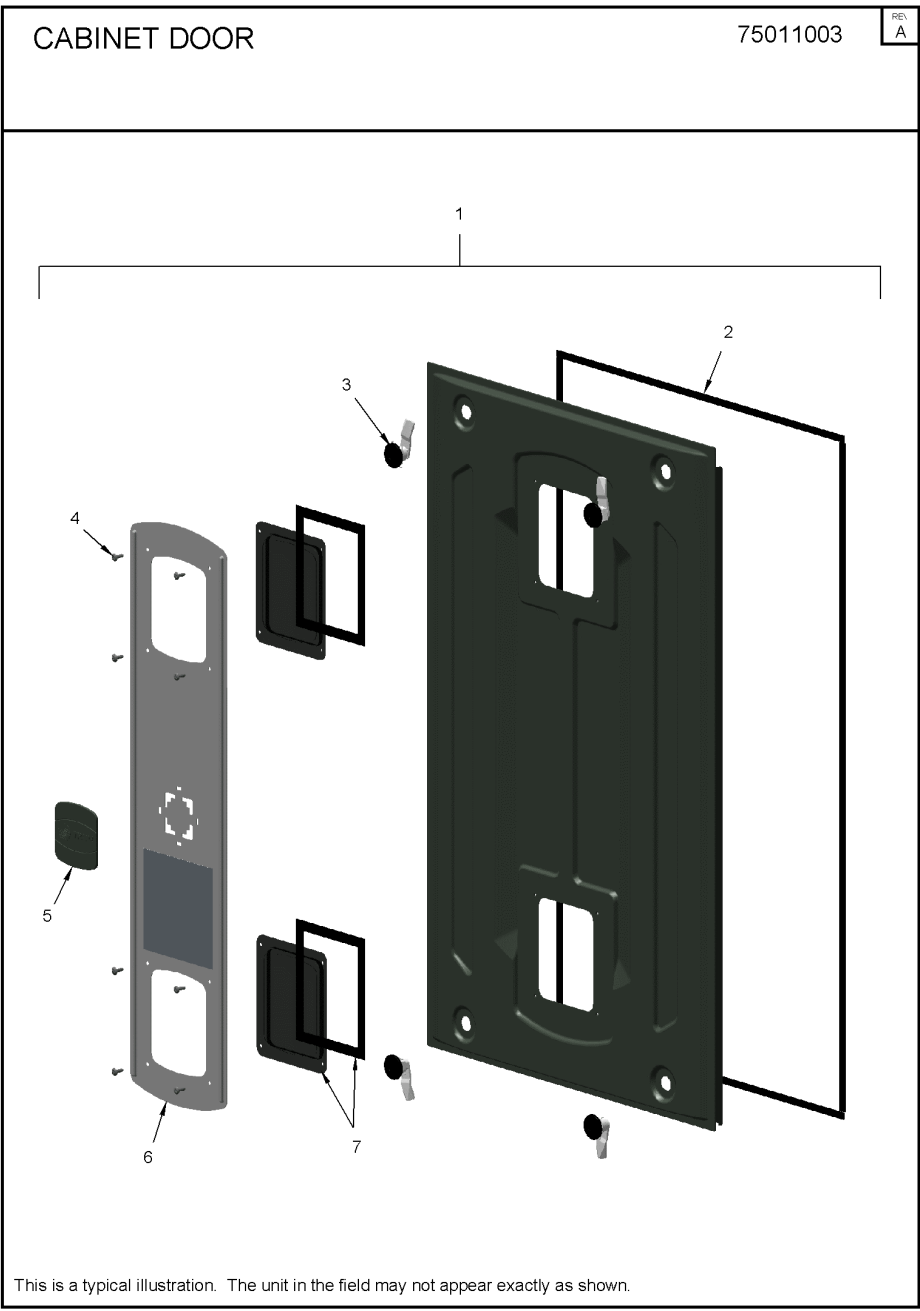

Part No.	Reference No.	Quantity	Description
PAI00248	*	1	PAINT; 12 OZ SPRAY, ANTHRACITE GRAY (SHIPPING UOM 12 OZ HAZ)
DOR04269	1	1	DOOR; ASSEMBLY, INCLUDES LATCH & CLIP, SIGHT GLASS, DOOR OVERLAY, BADGES, 19.48 X 33.13
GKT04783	2	1	GASKET; DOOR GASKETS, TOP/BOTTOM X 2, SIDES X 2, ONE SIZE FITS ALL - TRIM TO FIT
LAT01007	3	4	LATCH; DOOR, STEEL, WITH GASKET
SCR02475	4	8	SCREW; 8-18, TRUSS DRIVE STYLE, TYPE B BLUNT TIP
PLT05664	5	1	PLATE; TRANE BADGE, 3.17 X 3.00
PLT05665	5	1	PLATE; AMERICAN STANDARD BADGE, 3.17 X 3.00
PLT05663	6	1	PLATE; DOOR OVERLAY, 28.77 X 7.00
GLS01089	7	1	GLASS; ASSEMBLY, INCLUDES SITE-GLASS, GASKET, 8 SCREWS

SHIP WITH PARTS

75011131

REV.
A



This is a typical illustration. The unit in the field may not appear exactly as shown.

SHIP WITH COMPONENTS

Parts List Number :75011132#S9V2UP2

Model Number :S9V2B080D3PSBBA

Part No.	Reference No.	Quantity	Description
75011131_S9V2UP2_147494~P	*		SHIP WITH COMPONENTS PARTS LIST

SHIP WITH PARTS

75011131

REV.
A



This is a typical illustration. The unit in the field may not appear exactly as shown.

Part No.	Reference No.	Quantity	Description
TUB13975	1	1	TUBE; CONDENSATE DRAIN, INCLUDES CLAMPS, ADAPTER AND COUPLING
GRM01059	3	2	GROMMET; CONDENSATE GAS, BLACK 0.99 ID X 2.0 OD
KIT17675	4	1	KIT; 2 INCH INLET ADAPTOR (ADP01052) AND GASKET (GKT03082)
PLU01272	5	1	PLUG; GAS CONDENSATE, 1.5 INCH, BLACK PLASTIC
PLU01273	6	1	PLUG; ELECTRICAL, 1.0 INCH, BLACK PLASTIC
GRM01051	7	1	GROMMET; TRAP, 3.46 OD X 2.00 ID, PVC
KIT17674	8	1	KIT; OUTLET ADAPTOR WITH CLAMP AND GASKET

MODEL NUMBER DESCRIPTION

75011116

RB
B

S-SERIES FURNACE

Example Model Number:

S 9 V 2 B 0 8 0 U 3 P S A A A
1 - - - - 5 - - - - 10 - - - - 15

Digit 1 – Level

S = Series
L = 14 ng/J Ultra-Low NOx

Digit 2 – AFUE

8 = 80%
9 = 90% or higher

Digit 3 – Blower Type

B = Builder Series (May be PSC or CTM)
P = PSC
X = CTM
V = Variable Speed

Digit 4 – Gas Valve Stages

1 = SingleStage
2 = 2 Stage
M = Modulating

Digit 5 – Cabinet Width

A = 14.5 wide
B = 17.5 wide
C = 21.0 wide
D = 24.5 wide

Digits 6,7,8 – BTU input

080 = 80,000 BTUH

Digit 9 – Poise Options

U = 3 way
D = Dedicated Downflow
M = 4 Way Poise

Digit 10 – Airflow Capacity for Cooling

2 = 2 Tons
3 = 3 Tons
4 = 4 Tons
5 = 5 Tons

Digit 11 – Inducer Type

P = PSC
X = CTM
V = Variable Speed

Digit 12 – Communicating capability

S = 24 Volt
C = Communicating System Control
T = 24 Volt, 40ng/J NOx
D = Communicating System Control,
40ng/J NOx

Digit 13 – Major Design Change

Digit 14 – Minor Design Change

Digit 15 – Service Digit Change

Part No.	Reference No.	Quantity	Description
75011116_S9V2UP2_147493~P	*		MODEL NUMBER DESCRIPTION PARTS LIST

MODEL NUMBER DESCRIPTION S-SERIES FURNACE	75011116	RB B																
<p style="text-align: center;"><i>Example Model Number:</i> S 9 V 2 B 0 8 0 U 3 P S A A A <small>1 - - - - 5 - - - - 10 - - - - 15</small></p> <table border="0"><tr><td data-bbox="422 399 779 472">Digit 1 – Level S = Series L = 14 ng/J Ultra-Low NOx</td><td data-bbox="828 399 1023 493">Digit 11 – Inducer Type P = PSC X = CTM V = Variable Speed</td></tr><tr><td data-bbox="422 483 779 556">Digit 2 – AFUE 8 = 80% 9 = 90% or higher</td><td data-bbox="828 493 1120 630">Digit 12 – Communicating capability S = 24 Volt C = Communicating System Control T = 24 Volt, 40ng/J NOx D = Communicating System Control, 40ng/J NOx</td></tr><tr><td data-bbox="422 556 779 672">Digit 3 – Blower Type B = Builder Series (May be PSC or CTM) P = PSC X = CTM V = Variable Speed</td><td data-bbox="828 630 1088 661">Digit 13 – Major Design Change</td></tr><tr><td data-bbox="422 672 779 766">Digit 4 – Gas Valve Stages 1 = SingleStage 2 = 2 Stage M = Modulating</td><td data-bbox="828 661 1088 703">Digit 14 – Minor Design Change</td></tr><tr><td data-bbox="422 766 779 882">Digit 5 – Cabinet Width A = 14.5 wide B = 17.5 wide C = 21.0 wide D = 24.5 wide</td><td data-bbox="828 703 1088 745">Digit 15 – Service Digit Change</td></tr><tr><td data-bbox="422 882 779 945">Digits 6,7,8 – BTU input 080 = 80,000 BTUH</td><td></td></tr><tr><td data-bbox="422 945 779 1039">Digit 9 – Poise Options U = 3 way D = Dedicated Downflow M = 4 Way Poise</td><td></td></tr><tr><td data-bbox="422 1039 779 1155">Digit 10 – Airflow Capacity for Cooling 2 = 2 Tons 3 = 3 Tons 4 = 4 Tons 5 = 5 Tons</td><td></td></tr></table>			Digit 1 – Level S = Series L = 14 ng/J Ultra-Low NOx	Digit 11 – Inducer Type P = PSC X = CTM V = Variable Speed	Digit 2 – AFUE 8 = 80% 9 = 90% or higher	Digit 12 – Communicating capability S = 24 Volt C = Communicating System Control T = 24 Volt, 40ng/J NOx D = Communicating System Control, 40ng/J NOx	Digit 3 – Blower Type B = Builder Series (May be PSC or CTM) P = PSC X = CTM V = Variable Speed	Digit 13 – Major Design Change	Digit 4 – Gas Valve Stages 1 = SingleStage 2 = 2 Stage M = Modulating	Digit 14 – Minor Design Change	Digit 5 – Cabinet Width A = 14.5 wide B = 17.5 wide C = 21.0 wide D = 24.5 wide	Digit 15 – Service Digit Change	Digits 6,7,8 – BTU input 080 = 80,000 BTUH		Digit 9 – Poise Options U = 3 way D = Dedicated Downflow M = 4 Way Poise		Digit 10 – Airflow Capacity for Cooling 2 = 2 Tons 3 = 3 Tons 4 = 4 Tons 5 = 5 Tons	
Digit 1 – Level S = Series L = 14 ng/J Ultra-Low NOx	Digit 11 – Inducer Type P = PSC X = CTM V = Variable Speed																	
Digit 2 – AFUE 8 = 80% 9 = 90% or higher	Digit 12 – Communicating capability S = 24 Volt C = Communicating System Control T = 24 Volt, 40ng/J NOx D = Communicating System Control, 40ng/J NOx																	
Digit 3 – Blower Type B = Builder Series (May be PSC or CTM) P = PSC X = CTM V = Variable Speed	Digit 13 – Major Design Change																	
Digit 4 – Gas Valve Stages 1 = SingleStage 2 = 2 Stage M = Modulating	Digit 14 – Minor Design Change																	
Digit 5 – Cabinet Width A = 14.5 wide B = 17.5 wide C = 21.0 wide D = 24.5 wide	Digit 15 – Service Digit Change																	
Digits 6,7,8 – BTU input 080 = 80,000 BTUH																		
Digit 9 – Poise Options U = 3 way D = Dedicated Downflow M = 4 Way Poise																		
Digit 10 – Airflow Capacity for Cooling 2 = 2 Tons 3 = 3 Tons 4 = 4 Tons 5 = 5 Tons																		
1 of 1																		

