

## 195-0.13/0.25 ES-S

## 195-0.5 ES-S

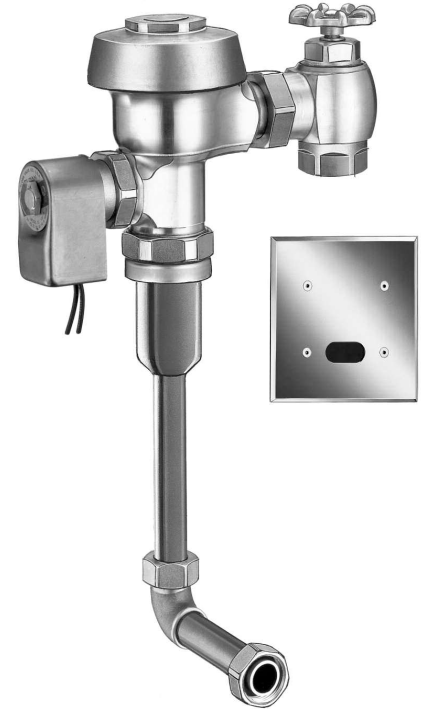

► **Description**

Concealed, Sensor Operated Royal® Model Urinal Flushometer, for 3/4" rear spud urinals.

► **Flush Cycle**

- Model 195-0.13 ES-S High Efficiency (0.13 gpf/0.5 Lpf)
- Model 195-0.25 ES-S High Efficiency (0.25 gpf/0.9 Lpf)
- Model 195-0.5 ES-S High Efficiency (0.5 gpf/1.9 Lpf)

► **Specifications**

Quiet, Concealed, Diaphragm Type or Cartridge Assembly, Rough Brass Urinal Flushometer for either left or right hand supply with the following features:

For flushing volumes 0.13 gpf or 0.25 gpf:

- Pressure compensating cartridge assembly
- Synthetic rubber seals for chloramine resistance

For flushing volumes 0.5 gpf or higher:

- PERMEX™ Synthetic Rubber Diaphragm with Dual Filtered Fixed Bypass
- Flush Accuracy Controlled by CID™ Technology
- Flex Tube Diaphragm designed to improve life and reduce maintenance
- OPTIMA® EL-1500 Self-Adaptive Infrared Sensor with Indicator Light
- Non-Hold-Open Integral Solenoid Operator
- Chrome Plated Wall Cover Plate (for 2-gang Electrical Box) with Vandal Resistant Screws
- 3/4" I.P.S. Wheel Handle Bak-Chek™ Angle Stop
- Adjustable Tailpiece
- High Back Pressure Vacuum Breaker Flush Connection and Spud Coupling for 3/4" Concealed Rear Spud
- Sweat Solder Adapter
- Chrome Plated Exposed Flushometer Parts
- High Copper, Low Zinc Brass Castings for Dezincification Resistance
- Non-Hold-Open Integral Solenoid Operator, Fixed Metering Bypass and No External Volume Adjustment to Ensure Water Conservation
- Diaphragm, Stop Seat and Vacuum Breaker to be molded from PERMEX™ Rubber Compound for Chloramine Resistance

Valve Body, Cover, Tailpiece and Control Stop shall be in conformance with ASTM Alloy Classification for Semi-Red Brass. Valve shall be in compliance with the applicable sections of ASSE 1037, ANSI/ASME A112.19.6. Installation conforms to ADA requirements.

► **L Dimension**

Specify the "L" Dimension for the proper length of the Flush Connection. The "L" Dimension is equal to the Wall Thickness (to nearest whole inch) plus 2 3/4".

► **Accessories**

- EL-154** Transformer (120 VAC/24 VAC, 50 VA)
- EL-342** Transformer (240 VAC/24 VAC, 50 VA)

See Accessories Section and OPTIMA® Accessories Section of the Sloan catalog for details on these and other OPTIMA® Flushometer variations.

► **Fixtures**

Consult Sloan for Sloan brand matching fixture options.

► **Automatic**

Sloan OPTIMA® equipped Flushometers provide the ultimate in sanitary protection and automatic operation. There are no handles to trip or buttons to push. The Flushometer operates by means of an infrared sensor that adapts to its surrounding. Once the user enters the sensor's effective range and then steps away, the Flushometer Solenoid initiates the flushing cycle to flush the fixture.

► **Hygienic**

User makes no physical contact with the Flushometer surface. Helps control the spread of infectious diseases. Twenty-four Hour Sentinel Flush keeps fixture fresh during periods of nonuse.

► **Economical**

Automatic operation provides water usage savings over other flushing devices. Reduces maintenance and operation costs.

► **Practical**

Solid state electronic circuitry assures years of dependable, trouble-free operation. The operational components of the Flushometer are identical to a handle operated Royal® Flushometer, proven by over 100 years of experience.

► **Warranty**

3 year (limited)

► **Made in the U.S.A.**

This space for Architect/Engineer approval	
Job Name _____	Date _____
Model Specified _____	Quantity _____
Variations Specified _____	
Customer/Wholesaler _____	
Contractor _____	
Architect _____	



# 195-0.13/0.25 ES-S 195-0.5 ES-S

## Description

Concealed, Sensor Operated Royal® Model Urinal Flushometer, for 3/4" top spud urinals.

## Flush Cycle

- Model 195-0.13 ES-S High Efficiency (0.13 gpf/0.5 Lpf)
- Model 195-0.25 ES-S High Efficiency (0.25 gpf/0.9 Lpf)
- Model 195-0.5 ES-S High Efficiency (0.5 gpf/1.9 Lpf)

## ELECTRICAL SPECIFICATIONS

### Control Circuit

Solid State  
24 VAC Input  
24 VAC Output  
8 Second Arming Delay  
24 Hour Sentinel Flush

### OPTIMA Sensor Range

Nominal 15" - 30" (381 mm - 762 mm)  
Self-adaptive Window ± 8" (203 mm)

### Solenoid Operator

24 VAC, 50/60 Hz

### Transformer

Sloan Part #EL-154  
120 VAC, 50/60 Hz Primary  
24 VAC, 50/60 Hz Secondary  
Class II, UL Listed, 50 VA.

Sloan Part #EL-342  
240 VAC, 50/60 Hz Primary  
24 VAC, 50/60 Hz Secondary  
Class II, UL Listed, 50 VA.

## WIRING DIAGRAM

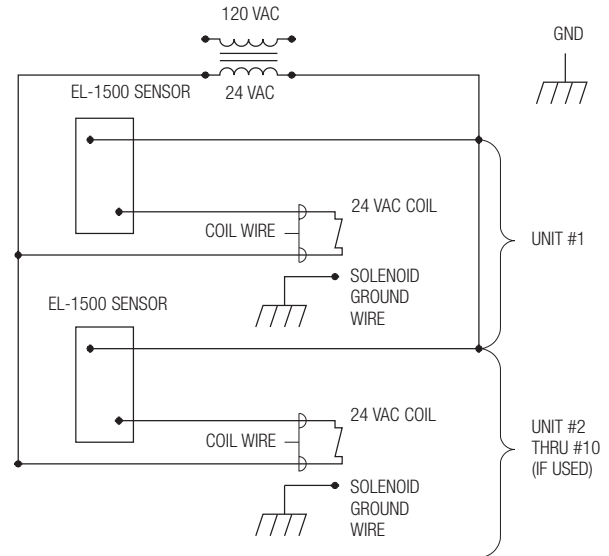

One Transformer serves up to ten (10) OPTIMA Closet/Urinal Flushometers. Specify number of transformers required accordingly.

## OPERATION

1. A continuous, invisible light beam is emitted from the OPTIMA Sensor.

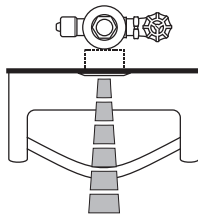

2. As the user enters the beam's effective range (15" to 30") the beam is reflected into the OPTIMA Scanner Window and transformed into a low voltage electrical circuit. Once activated, the Output Circuit continues in a "hold" mode for as long as the user remains within the effective range of the Sensor.

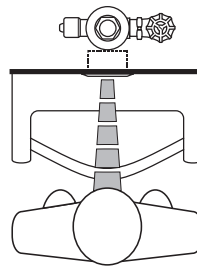

3. When the user steps away from the OPTIMA Sensor, the circuit immediately initiates an electrical "one-time" signal that operates the Solenoid. This initiates the flushing cycle to flush the fixture. The Circuit then automatically resets and is ready for the next user.

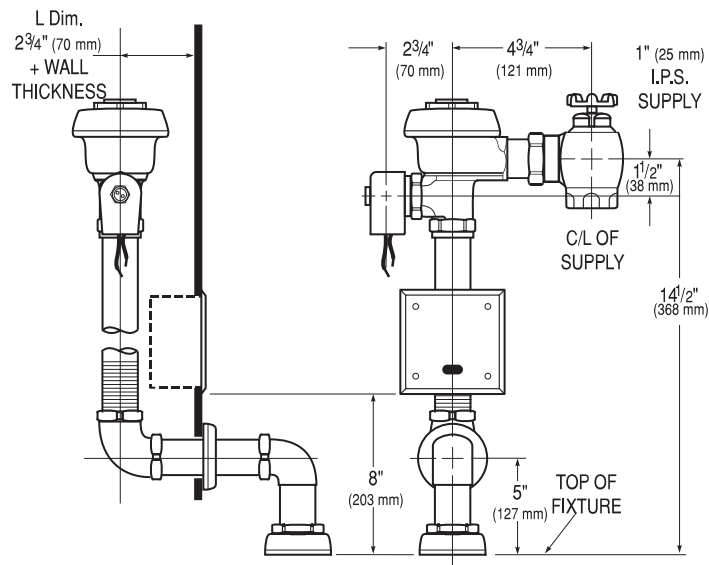
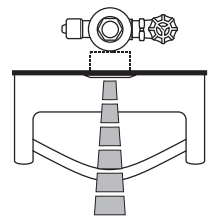

## ELECTRICAL BOX INSTALLATION

### SENSOR LOCATION AND POSITIONING IS CRITICAL

Failure to properly position the electrical boxes to the plumbing rough-in will result in improper installation and impair product performance. All tradesmen (plumbers, electricians, tile setters, etc.) involved with the installation of this product must coordinate their work to assure proper product installation.

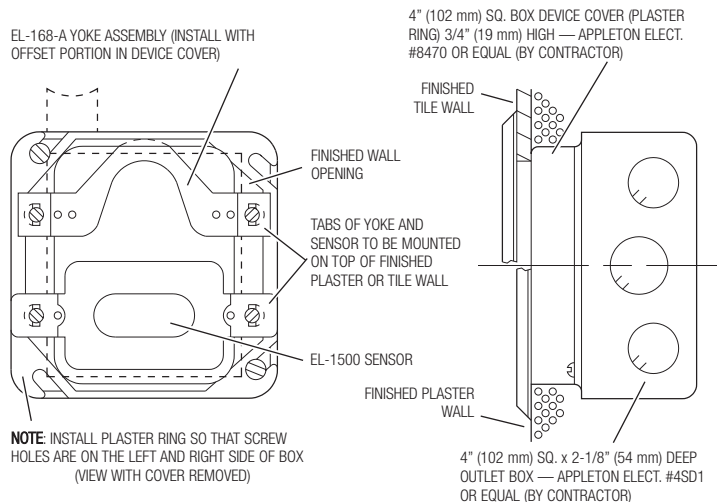

**SLOAN VALVE COMPANY • 10500 SEYMOUR AVENUE • FRANKLIN PARK, IL 60131**

Phone: 1-800-9-VALVE-9 or 1-847-671-4300 • Fax: 1-800-447-8329 or 1-847-671-4380 • <http://www.sloanvalve.com>