



RCK-862 *plus*



USB



Graphic Display



Supervisory System



Hour meter



Alarms



Progressive Algorithm



Suction Control



Discharge Control



Floating Condensation



Preset System

1. SUMMARY

1. SUMMARY.....	2
2. DESCRIPTION.....	4
3. APPLICATIONS.....	5
4. GLOSSARY.....	5
5. TECHNICAL SPECIFICATIONS.....	6
6. ELECTRICAL PRECAUTIONS.....	6
7. INSTALLING THE RCK-862 plus	7
8. DIMENSIONS.....	7
9. WIRING SCHEMATICS.....	8
10. NAVIGATION KEYS.....	9
11. NAVIGATION TUTORIAL.....	10
12. SUMMARY SCREENS.....	11
12.1 GROUP (S) SUMMARY SCREENS.....	11
12.2 SUCTION SUMMARY SCREENS.....	12
12.3 DISCHARGE SUMMARY SCREENS.....	14
12.4 CONTINUATION OF SUMMARY SCREENS.....	16
12.5 INDIVIDUAL PRESSURE.....	17
12.6 INDIVIDUAL THERMOSTATS.....	18
12.7 INPUTS AND OUTPUTS.....	19
12.8 AUXILIARY INPUT.....	20
12.9 ALARM OUTPUT.....	20
12.10 COMPRESSOR PROTECTION THERMOSTATS.....	21
12.11 PUMP CONTROL.....	21
13. CONTROL MENU.....	22
14. COOLING GROUPS.....	23
14.1 SUCTION CONTROL.....	23
15. SUCTION CONTROLS.....	25
15.1 SUCTION CONTROL.....	25
15.2 MODULATION OF ON/OFF COMPRESSORS.....	25
15.3 MODULATION OF VARIABLE CAPACITY COMPRESSORS (VCC).....	26
15.3.1 VCC-ANALOG.....	26
15.3.2 VCC-DIGITAL.....	26
15.4 CONTROL MODES.....	27
15.4.1 LINEAR MODE.....	27
15.4.1.1 LINEAR MODE LINKED ONLY WITH DIGITAL OUTPUTS-COMPRESSORS ON/OFF+UNLOADERS.....	27
15.4.1.2 LINEAR MODE LINKED WITH A VCC COMPRESSOR IN CONJUNCTION WITH ON/OFF COMPRESSORS.....	28
15.4.1.3 LINEAR MODE LINKED WITH A VCC-ANALOG COMPRESSOR.....	29
15.4.1.4 LINEAR MODE LINKED WITH A VCC-DIGITAL COMPRESSOR.....	29
15.4.2 ROTATION MODE.....	30
15.4.3 DEAD ZONE MODE.....	30
15.4.4 DEAD ZONE MODE WITH ROTATION.....	30
15.4.5 PROGRESSIVE ALGORITHM MODE.....	31
15.4.6 SATURATION TEMPERATURE CONTROL.....	32
15.4.7 CONTROL BY TEMPERATURE OF A SECONDARY FLUID.....	32
15.4.8 INTEGRAL ACTION.....	33
15.4.9 LOW PRESSURE DISCONNECTION.....	34
16. DISCHARGE CONTROLS.....	35
16.1 CONTROL MODES.....	35
16.2 TYPES OF DISCHARGE CONTROL.....	35
16.2.1 LINEAR MODE.....	35
16.2.1.1 LINEAR MODE LINKED ONLY WITH DIGITAL OUTPUTS-FANS ON/OFF.....	35
16.2.1.2 INVERTER MODULATOR FAN.....	35
16.2.1.3 LINEAR MODE USING A FAN (INVERTER) IN CONJUNCTION WITH FANS LINKED WITH DIGITAL OUTPUTS.....	36
16.2.2 ROTATION.....	36

1. SUMMARY

16.2.3 DEAD ZONE.....	36
16.2.4 DEAD ZONE+ROTATION.....	36
16.2.5 INTEGRAL ACTION.....	37
17. AUXILIARY FUNCTIONS.....	38
17.1 PUMP DOWN.....	38
17.2 AUTOMATIC SHUTDOWN COMMANDED BY RCK-862 plus	39
17.3 AUTOMATIC SHUTDOWN COMMANDED BY THERMOSTATS.....	41
17.4 PUMP CONTROL.....	43
17.5 DEFROSTING FOR SUCTION LINES.....	44
17.6 DEFROSTING FOR TIME.....	44
17.7 DEFROSTING BY SCHEDULE.....	44
17.8 COMPRESSOR PROTECTION THERMOSTATS.....	45
17.9 ADIABATIC CONDENSATION.....	45
17.9.1 TEMPERATURE CONTROLLING.....	45
17.9.1.1 TEMPERATURE CONTROLLING USING TWO SENSORS (DIFFERENTIAL TBS-TBU).....	46
17.9.1.2 TEMPERATURE CONTROLLING USING A SENSOR (TBS).....	46
17.9.1.3 TEMPERATURE CONTROLLING USING TWO SENSORS (TBS-TBU DIFFERENTIAL AND TEMPERATURE LIMIT).....	46
17.10 CYCLE TIMER MODE.....	46
17.11 DYNAMIC CONDENSATION.....	47
17.12 INDIVIDUAL PRESSOSTAT.....	47
17.13 INDIVIDUAL THERMOSTATS.....	48
17.14 PUMP CONTROL.....	48
17.15 CONTROL STATUS.....	48
18. ALARMS.....	49
18.1 ALARM VIEW.....	49
18.2 AUTOMATICS RESETS.....	50
18.3 OUTPUT SIGNALING.....	50
18.4 ALARM TABLES.....	51
18.4.1 SYSTEM ALARMS.....	51
18.4.2 SUCTION ALARMS.....	51
18.4.3 DISCHARGE ALARM.....	54
18.4.4 INDIVIDUAL PRESSOSTAT ALARMS.....	56
18.4.5 INDIVIDUAL THERMOSTAT ALARMS.....	56
18.4.6 ROTATION OUTPUT ALARMS.....	56
18.4.7 COMMUNICATION ALARMS WITH EXPANSIONS.....	56
19. MAIN MENU.....	57
19.1 FUNCTIONS SETTINGS.....	57
19.2 SYSTEM SETTINGS.....	58
19.3 COMMUNICATION SETTINGS.....	58
19.3.1 COMMUNICATION WITH SITRAD.....	59
19.3.2 MODBUS COMMUNICATION.....	59
19.4 EXPANSIONS.....	59
19.5 DATA MANAGEMENT.....	61
19.5.1 EXPORTING PRESET.....	61
19.5.2 IMPORTING PRESET.....	61
19.5.3 FIRMWARE UPDATE.....	61
19.6 RESTORING FACTORY DEFAULT SETTINGS.....	61
20 PARAMETER TABLE.....	62
21 IMPORTANT.....	90
22 WARRANTY TERM.....	90

2. DESCRIPTION

The **RCK-862 *plus*** is an expandable electronic controller from the Rackcontrol line for application in commercial and industrial refrigeration compression plants. It can control in low and medium temperature applications with up to three suction lines and three discharge lines. In addition to controlling and monitoring, it has two independent RS-485 communication ports that can be used for remote control via Sitrad software or other equipment via MODBUS protocol.

The **RCK-862 *plus*** is capable of controlling pressure or temperature, through its 6 configurable inputs for sensors and 8 digital inputs for monitoring devices and external drivers. Its robust hardware also has eight control outputs for compressors or fans, two analog outputs for proportional control and six digital outputs (three relay outputs and three solid state type) for ON-OFF control of compressors, unloader valves and fans. Its three solid state relays can be used together with dedicated logic for controlling digital compressors of variable capacity. The **RCK-862 *plus*** is a control module that acts alone or together with expansion modules to increase the number of inputs and outputs in large systems.

The **RCK-862 *plus*** is capable of regulating compressors using pressure sensors to control the pressure or saturation temperature of the refrigerant, or use temperature sensors to directly control the temperature of secondary circuits such as glycol and water chiller.

The **RCK-862 *plus*** has advanced control logic to optimize thermal performance and reduce the energy consumption of the cooling system. The proportional-integral control seeks to minimize the variation in temperature/pressure of the suction line. The progressive algorithm, which seeks to match the cold demand required by the plant with the power of the set of compressors, seeking to reduce the number of compressor actuations and shutdowns. The floating condensation control logic, where the temperature of the external environment is monitored to reduce the condensation setpoint, consequently reducing the compression ratio of the system and its energy consumption.

The **RCK-862 *plus*** has a user-friendly interface through a high-brightness OLED display, six interaction keys and a control menu that provides the commands most used by the compression center. Simple to operate and configure, the **RCK-862 *plus*** is equipped with an internal buzzer (audible warning), key and screens for monitoring alarms that simplify the process of monitoring and identifying faults in the refrigeration system. There is also a real-time clock (RTC) that allows you to automate commands and record the times of alarms. The USB connection can be used to upload and download configuration parameters, as well as to update the firmware.

3. APPLICATION

- Low and medium power industrial refrigeration
- Rack type refrigeration equipment (compressors in parallel)
- Compression centers for supermarkets, logistic storage centers or air conditioning systems
- Cold storage facilities
- Condensing units
- Plug-ins

4. GLOSSARY

Group: It is a set of suction or discharge lines that are linked (same refrigerator circuit).

Control line: A circuit section with the same pressure or temperature control, for example: suction or discharge.

Unloader: Capacity regulating valve on compressors.

Hysteresis: Range of variation of the control parameter, also known as Control differential.

Setpoint: Desirable value of the control parameter (pressure or temperature).

Pressostat: Pressure control based on a setpoint and a hysteresis.

Thermostat: Temperature control based on a setpoint and a hysteresis.

Superheating: Temperature difference above a refrigerant's boiling point for a given pressure.

Subcooling: Temperature difference below the dew point of a refrigerant for a given pressure.

Compression: Pressure control where the hysteresis interval is below the setpoint.

Decompression: Pressure control where the hysteresis interval is above the setpoint.

SSR: Solid State Relay. Electronic device for driving electric loads that allows a higher frequency of switching than electro-mechanical relay. Used to drive alternating current (AC) charges only.

VCC: Variable Compressor Capacity Compressor. Name the compressor that allows modulation within a continuous range, usually between 10 and 100%.

VCC-Analog: Compressor whose capacity is modulated by means of an analog output from the controller (0-10V signal).

VCC-Digital: Compressor whose capacity is modulated through the actuation of digital outputs (SSRs) to control unloaders valves.

Primary fluid: Compressor whose capacity is modulated by means of an analog output from the controller (0-10V signal).

Secondary fluid: Compressor whose capacity is modulated through the actuation of digital outputs (SSRs) to control unloaders valves.

Saturation temperature: Compressor whose capacity is modulated by means of an analog output from the controller (0-10V signal).



Have this manual at the palm of your hand through the FG Finder application

5. TECHNICAL SPECIFICATIONS

Power Supply	24Vac 50/60Hz or 24Vdc± 10%
Maximum consumption	500mA ac/dc
Controller operating temperature	0 to 50°C
Operating Humidity Range	10 to 90% UR (without condensation)
Type action	Type 1.B
Pollution degree	II
Software class	Class A
Control pressure	0.1 psi / 0.1 bar
Pressure resolution range	-14,7 to 850psi / -1,0 to 58,7 bar
Control temperature range	-50 to 200°C / -58 to 392°F
Temperature resolution	0.1°C / 0.1 °F across all range
Analog inputs	S1 to S6: Configurable between pressure sensor (4 to 20mA / SB69) or temperature sensor (SB19, SB41, SB59, SB70);
Voltage output for pressure sensors	Voltage output +12V: 12Vdc, Idcmax= 120mA;
Digital inputs	I1 to I5: dry contact type digital inputs. Hi1 to Hi3: Isolated digital inputs, with maximum voltage equal to the supply voltage (24V)
Analog outputs	A1 A2 = 0-10Vdc (max. 10mA)
Digital outputs	O1, O5 and O6: relay output (SPST) NO, 5(3)A/250Vac; O2, O3, and O4: output with solid state relay (SSR) 1A/24 - 240Vac
USB Interface	Compatible with the USB 2.0 Full-Speed Module (USBFS) standard; Data format for FAT32 pendrive / Maximum size of 32GB pendrive
RS-485 communication interface	RS485-1: Not insulated RS485-2: Insulated EXP: Communication with expansion modules
Product dimensions (LxAxP)	70,0 x 135,7 x 61,7 mm (2,76" x 5,34" x 2,43")

6. ELECTRICAL PRECAUTIONS

 **BEFORE INSTALLING THE CONTROLLER, WE RECOMMEND THAT THE FULL READING OF THE INSTRUCTION MANUAL BE DONE, IN ORDER TO AVOID POSSIBLE DAMAGE TO THE PRODUCT.**

 **PRECAUTION WHEN INSTALLING THE PRODUCT:**

- Before performing any procedure on this instrument, disconnect it from the power supply;
- Certify that the instrument has adequate ventilation, avoiding installation on panels that contain devices that may cause it to operate outside the specified temperature limits;
- Install the product away from sources that may generate electromagnetic disturbances, such as: motors, contactors, relays, solenoid valves, etc.

 **AUTHORIZED SERVICE:**

- Installation or maintenance of the product must be performed only by qualified professionals.

 **ACCESSORIES:**

- Use only Full Gauge Controls original accessories;
- In case of doubt, contact technical support.

BEING IN CONSTANT DEVELOPMENT, FULL GAUGE CONTROLS RESERVES THE RIGHT TO CHANGE ANY INFORMATION IN THE MANUAL AT ANY TIME, WITHOUT PRIOR NOTICE.

7. INSTALLING THE RCK-862 *plus*

7.1 Fixing by DIN rail.

To fix the interface on the DIN rail, position the interface fit the top part in place as shown.

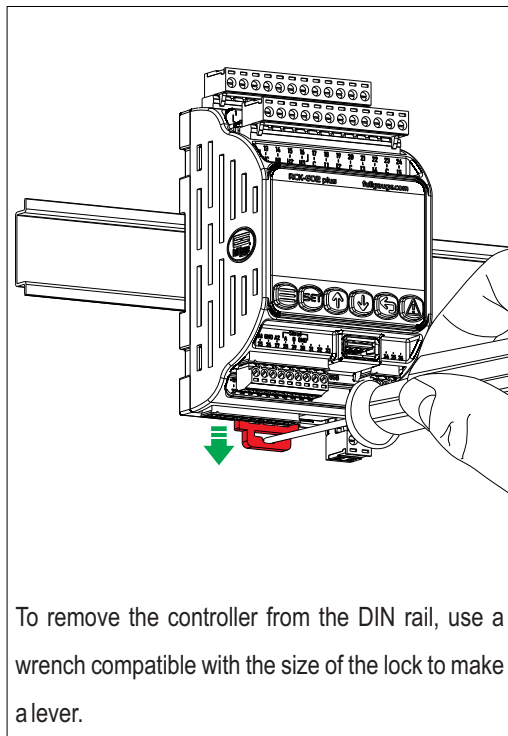
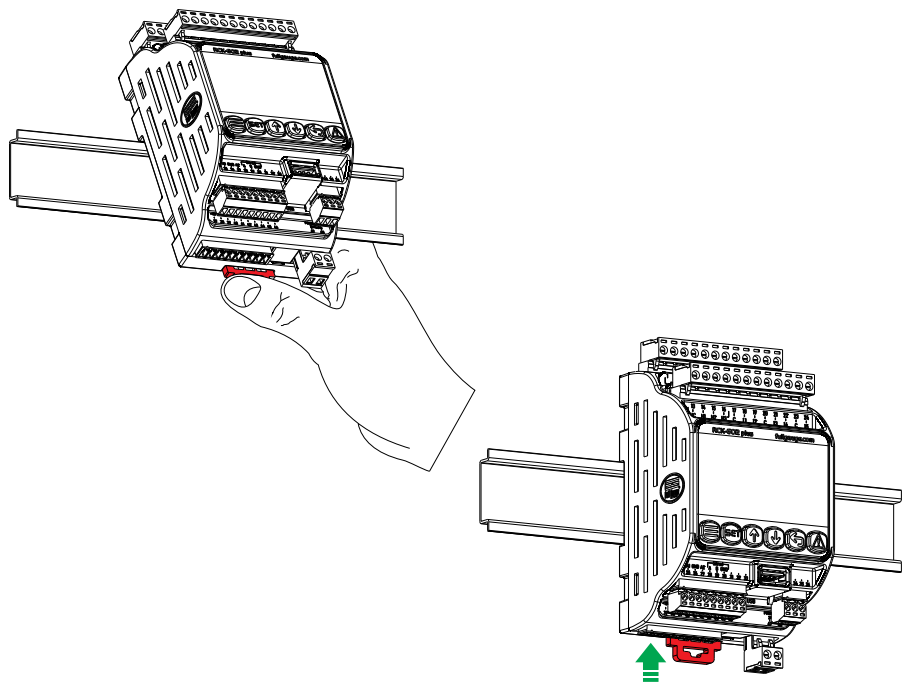

To remove the controller from the DIN rail, use a wrench compatible with the size of the lock to make a lever.

8. DIMENSIONS

For a better fixation of the **RCK-862 *plus*** observe the product dimensions.

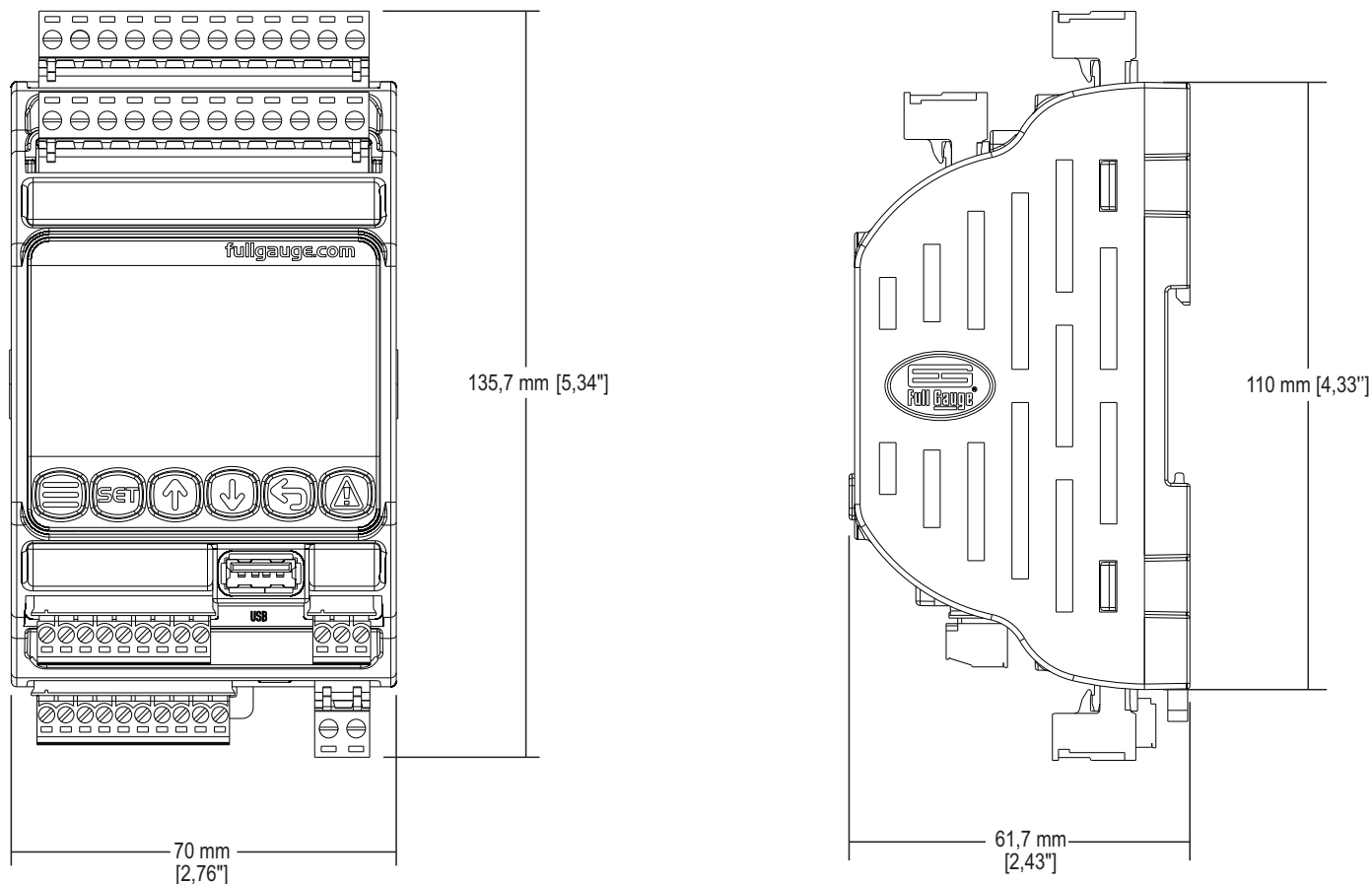

9.CONNECTION SCHEMATICS

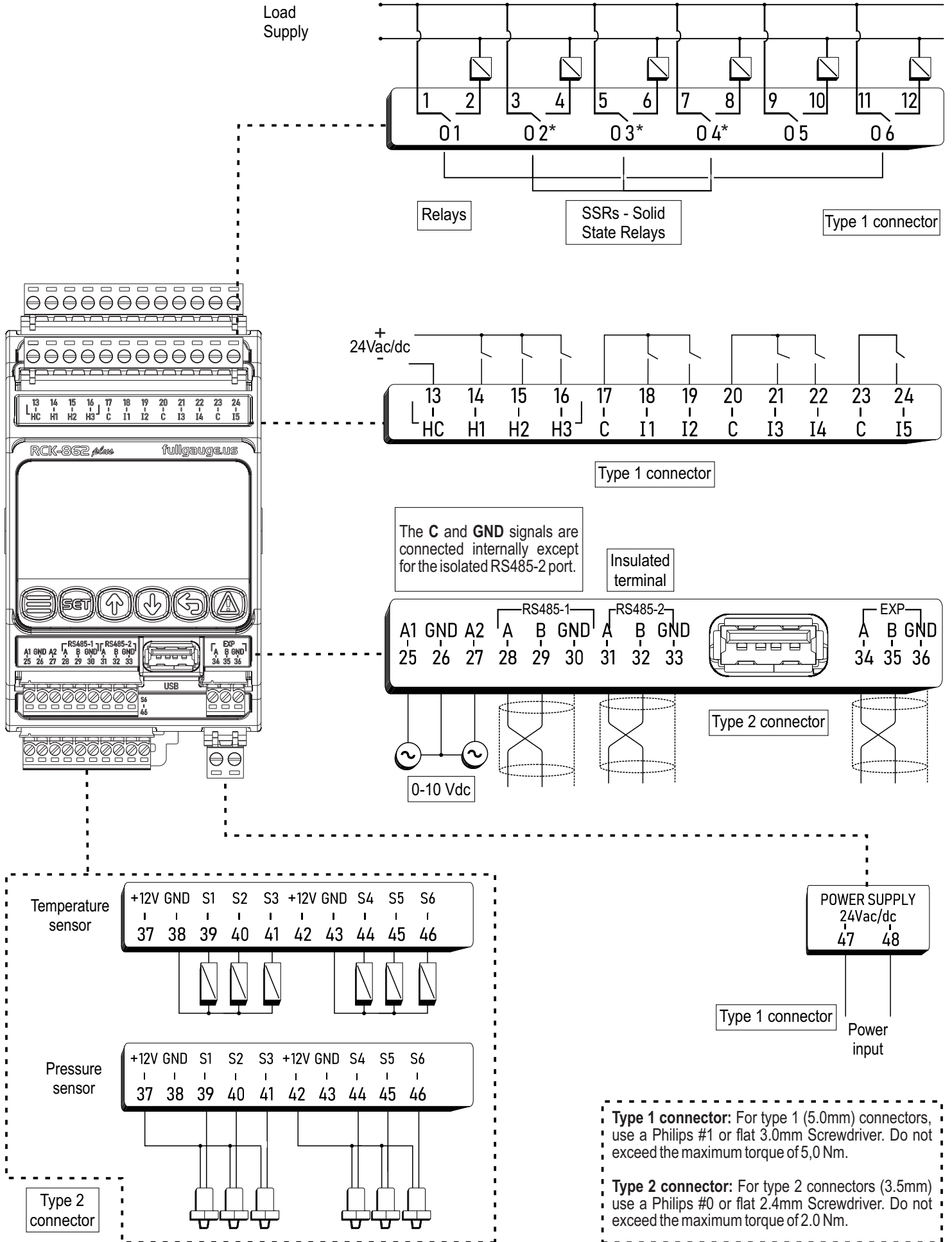

Note: You can install up to 6 sensors configurable between temperature and pressure depending on the installation.

10.NAVIGATION KEYS

To toggle between screens, edit parameters, view advanced functions and other features, the **RCK-862_{plus}** has 6 navigation keys:

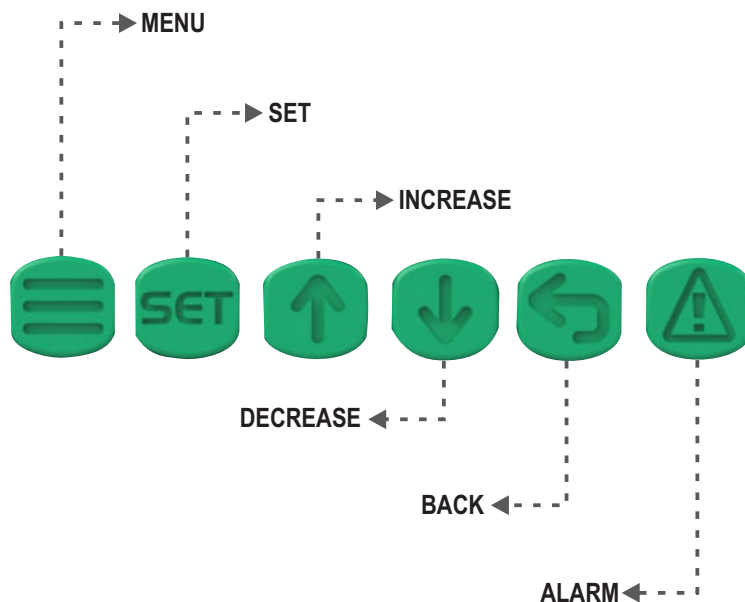

MENU key: Access the Main Menu and the Control Menu.

Control Menu: Press the MENU key.

Main Menu: Press and hold the MENU key for 2 seconds.

SET key: Confirms and edits the parameters and values.

INCREASE key: Increases values and navigates "up" up through menu options.

DECREASE key: Decreases values and navigates "down" down through menu options.

BACK key: Returns to the previous screen without saving parameter changes.

ALARM key: Access the display of active alarms, alarm history and alarms on reset.

Press the alarm key to switch between the Active Alarms, Alarm History and Reset Alarms screens. To clear the alarm history or view the alarm history press and hold the alarm button for 5 seconds.

Note: requires Administrator access level.

11.NAVIGATION TUTORIAL

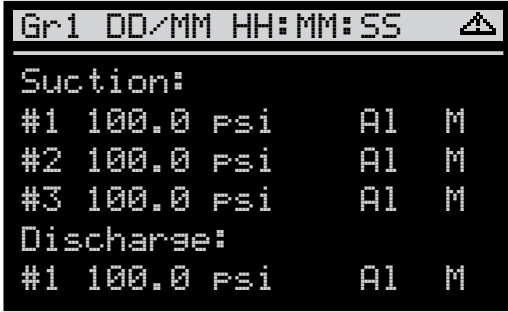

The first summary screen is the **GROUP 1**. You can find information about the controlled system.



By using the **INCREASE** and **DECREASE** keys it is possible to navigate through the other summary screens.

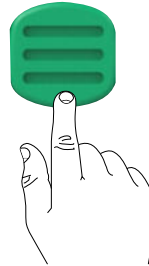
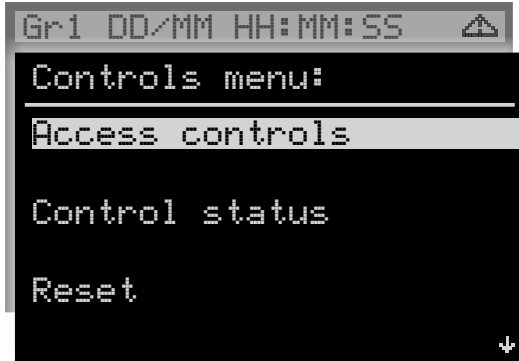

A short press on the **MENU** key accesses the Control Menu. This menu presents the main commands and settings for system operation.

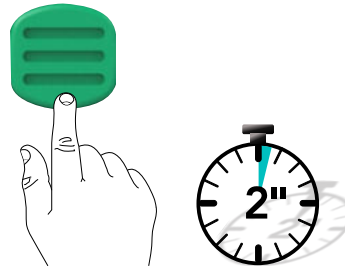
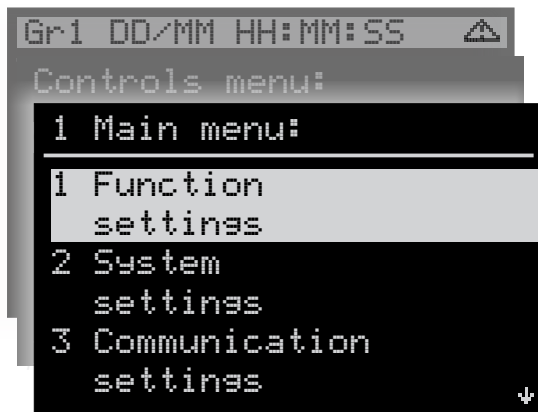

Press the **MENU** key for 2 seconds to access the Main Menu. The Main Menu groups the cooling system settings to be controlled.

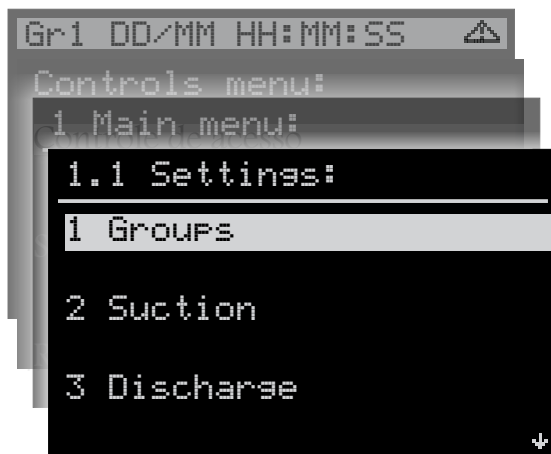

The **SET** key is used to access the selected settings options.

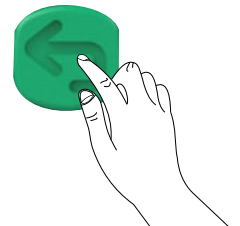

The **BACK** key is used to return to the configuration menus, with a short touch it is possible to return to the previous level.

12.SUMMARY SCREEN

12.1. Group summary screen:

Displays the basic status of the lines (Suction and/or Discharge) that make up the group, when configured to display it. By default, the **RCK-862^{plus}** is configured with Suction 01 and Discharge 01 in Group 01. If the Group is not configured, access the **Main Menu** → **Function Settings** → **Groups**. For more information see section 18. **Main Menu** → **Function 1.1.1**

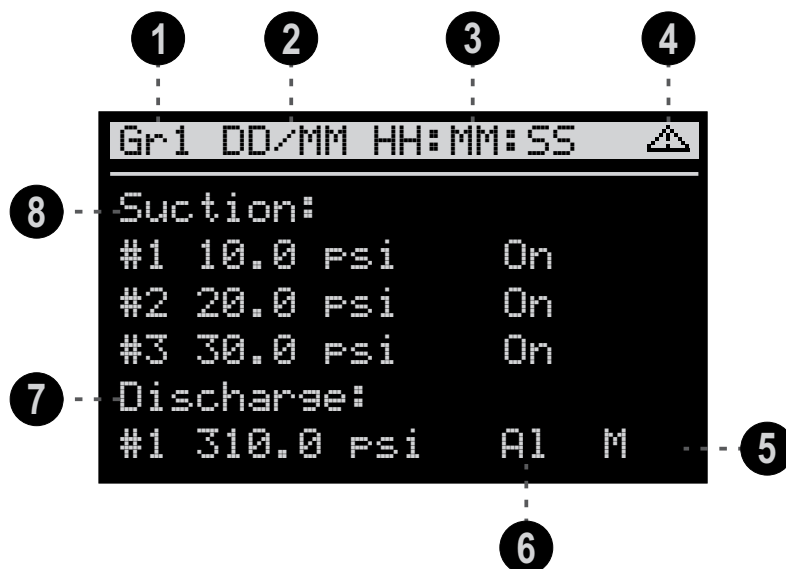

1 – Group identification on display:

Gr 1: Group 1;

Gr 2: Group 2;

Gr 3: Group 3.

2 – DD/MM : Indicates the current date.

3 – HH:MM:SS :Reports current time.

4 – [Alarm Icon] : Indication of active alarm.

5 – Auxiliary indications:

M: At least 1 compressor or fan in maintenance;

Eco: When the economic setpoint is active;

Pd: In the process of Pump Down;

FLT: Active floating condensation;

ADI: Active adiabatic condensation.

Note: When more than one auxiliary function is active on the same line (Suction or Discharge), the icons will alternate on the display.

6 – Indication of control status:

Wait: Waiting for control to start;

On: Turn On;

Off: Turn Off;

Lock: Locked;

A1: In alarm or automatic reset;

A1 (Blinking): Waiting for manual reset;

Def: Defrost.

7 – Displays the discharge pressure switch configured for the group. If there is no discharge enable, an empty line will display.

Note: The group number determines the number of the discharge line that will be used. For example, discharge 03 will only be used in group 03.

8 – Displays the number of suction pressure switches configured for the group. If there is no suction enabled, an empty line will display.

12.SUMMARY SCREEN

12.2. Suction summary screen:

On this screen it is possible to view the basic suction status.

To configure the Suction lines, access the **Main Menu** → **Function settings** → **Suction**. For more information see section 18. **Main Menu** → **Function** 1.1.2

Pressure control:

	1	2	3	4	5	6
	Suc1	On	Eco	Pd	M	▲
12	Set:		30.0	PSI		
11	Pres:	(-24.0°C)	35.0	PSI		
10	Temp:		-5.0	°C		
9	Superheating:		5.0	°C		
	Req:	100%	Out:	100%		
	8				7	

	15	14	13			
	Suc1	On	Eco	Pd	M	▲
	T.input:		8.0	°C		
	T.output:		2.0	°C		
	ΔT:		6.0	°C		
	Req:	100%	Out:	100%		

Saturation temperature control:

	1	2	3	4	5	6
	Suc1	On	Eco	Pd	M	▲
	Set:		-30.0	°C		
	Pres:	(35.0 PSI)	-24.0	°C		
	Temp:		-19.0	°C		
	Superheating:		5.0	°C		
	Req:	100%	Out:	100%		

	15	14	13			
	Suc1	On	Eco	Pd	M	▲
	T.input:		8.0	°C		
	T.output:		2.0	°C		
	ΔT:		6.0	°C		
	Req:	100%	Out:	100%		

Secondary fluid temperature control:

	1	2	3	4	5	6
	Suc1	On	Eco	Pd	M	▲
	Set:		4.0	°C		
	T.input:		8.0	°C		
	T.output:		2.0	°C		
	ΔT:		6.0	°C		
	Req:	100%	Out:	100%		

	15	14	13			
	Suc1	On	Eco	Pd	M	▲
	Pres:	(35.0 PSI)	-24.0	°C		
	Temp:		-19.0	°C		
	Superheating:		5.0	°C		
	Req:	100%	Out:	100%		

12.SUMMARY SCREEN

- 1 – Identification of the suction line on display:
Suc1: Suction 1;
Suc2: Suction 2;
Suc3: Suction 3.
- 2 – Control status indication:
Wait: Waitin for control to start;
On: Turn On;
Off: Turn Off;
Lock: Locked;
Al: In alarm or automatic reset;
Al (Blinking): Waiting for manual reset;
Cf@: Line with no configuration parameter.
- 3 – Eco: Active economic setpoint.
- 4 – Pd: In the process of Pumping Down.
- 5 – M: At least 1 compressor in maintenance.
- 6 – : Indication of active alarm.
- 7 – Out: Percentage of power referring to the active outputs by **RCK-862 plus**.
- 8 – Req: Percentage of power required by the system for the operating interval.
- 9 – Superheating: Calculation of overheating based on pressure measurement, temperature, and type of parameterized refrigerant. If the controller identifies that the suction is working in the transcritical part of the refrigerant, the message PC will be displayed.
- 10 – Temp: It is the value of the suction evaporation temperature sensor.
- 11 – Pres: It is the pressure value read by the suction transducer.
- 12 – Set: Display the current value of the setpoint, it can be the economic pressure setpoint or the main pressure setpoint. (Depending on which is active).
- 13 – Δ : It is the difference between the input and output temperatures of the secondary circuit.
- 14 – T. output: It is the value of the fluid outlet temperature of the secondary circuit.
- 15 – T. input: It is the value of the inlet temperature of the fluid in the secondary circuit.

12.SUMMARY SCREEN

12.3. Discharge summary screen:

Displays the basic status of the enabled Discharge line.

To configure the Discharge lines, access the **Main Menu** → **Function Configuration** → **Discharge**. For more information see section 18. **Main Menu** → **Function 1.1.3**

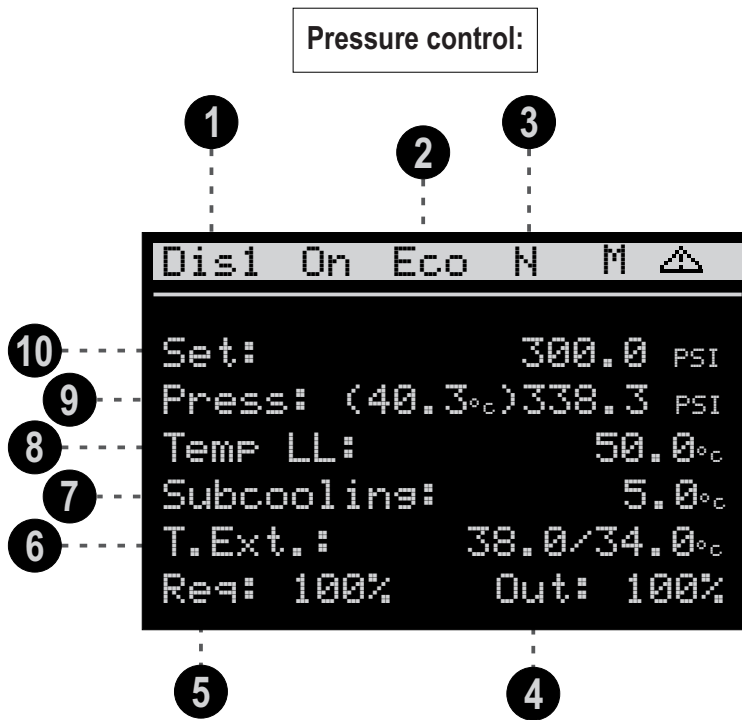

Saturation temperature control:

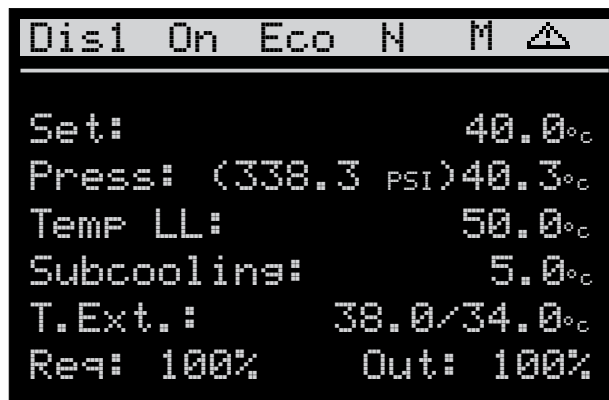

Liquid line temperature control

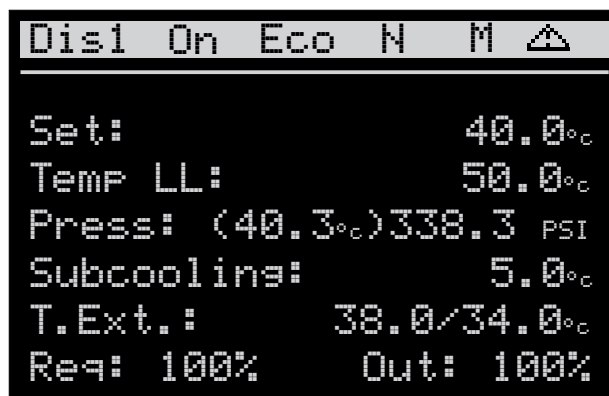

12.SUMMARY SCREEN

- ① – Identification of the discharge line on display:
Dis1: Discharge 1;
Dis2: Discharge 2;
Dis3: Discharge 3.
- ② – Eco: Active economic setpoint.
- ③ – N: In night mode.
- ④ – Out: Percentage of power referring to the active outputs by the **RCK-862 plus**.
- ⑤ – Req: Percentage of power required by the system for the operation interval.
- ⑥ – T.Ext.: Represents the value of the external temperature sensor (s) used in the floating and adiabatic condensations. The value on the left indicates the value of the dry bulb temperature sensor (configured in menu 1.3.✕). The value on the right represents the wet bulb sensor (configured on Adiabatic Condensation settings - 1.7.3.✕). This information will only be displayed if the sensors are parametrized.
- ⑦ – Subcooling: Calculation of subcooling based pressure measurement, temperature, and type of refrigerant settings. If the controller identifies the suction that is operating in the transcritical part of the refrigerant, the message PC will be displayed.
- ⑧ – Temp LL: It is the temperature value of the liquid line, used for calculate subcooling.
- ⑨ – Pres: It is pressure value read by the discharge transducer
- ⑩ – Set: Displays the active pressure or temperature setpoint value. It can be the main or economic setpoint or resulting from the calculation of the floating condensation logic.

12.SUMMARY SCREEN

12.4. Continuation of summary screens:

For each suction and discharge has a summary screen where you can see how many outputs are connected and their respective status. After the equal sign, you can see the percentage number of the control outputs connected with each compressor and fan that are on. It can even monitor the capacity control status (unloaders valves and inverter output).

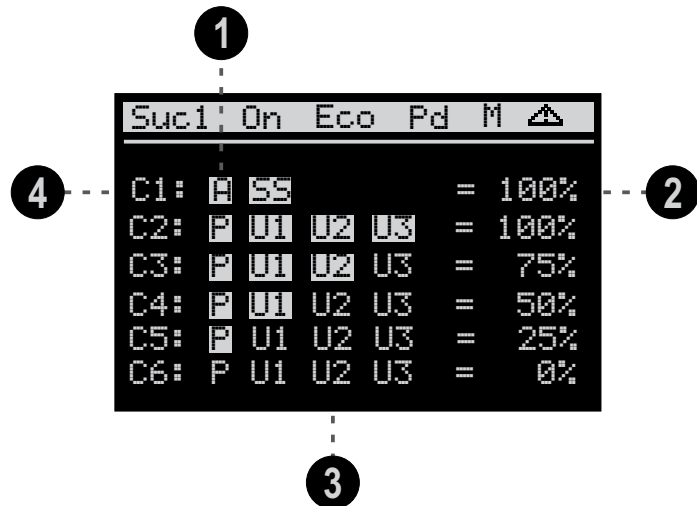

1 – The letter P represents the activation of the compressor's main output. When digital output P is indicated with a white background, it means the relay is activated.
The letter A symbolizes the analog (proportional) output-compressor configured as an inverter. For values above 0% the letter A is displayed with a white background.

2 – This value represents the percentage of the power supplied by each compressor

3 – The auxiliary outputs (unloaders) are represented by the letter U.
The Start-Stop output of the compressor with VCC-Analog modulation will be represented by the letters SS

4 – Lists all compressors enabled on the suction pressure switch.

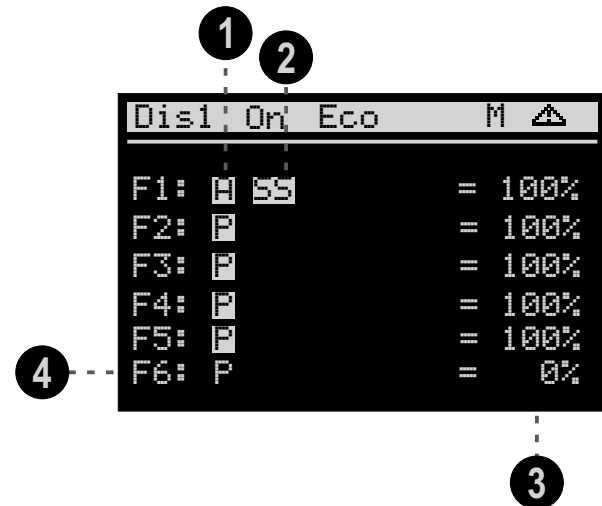

1 – The letter P represents the actuation of the fan output. When digital output P is indicated with a white background, it means that its relay is activated.
For fans with inverter modulation (only the F1 fan can be configured) the letter A symbolizes the value of the analog output. For values above 0% the letter A will be shown with a white background.

2 – For fans with modulation, the SS symbol represents the status of the Start-Stop output.
When this output is activated, it is represented with a white background.

3 – This value represents the percentage of the power supplied by each fan.

4 – It lists all enabled fans of the discharge line, there could be total of six.

White background

Actuated output

Black background

Output configured but shutdown

12.SUMMARY SCREEN

12.5. Individual pressure switches:

The individual pressure switch screens are accessed from the Control Menu.

To toggle between the available pressure switches just navigate using the keys  and .

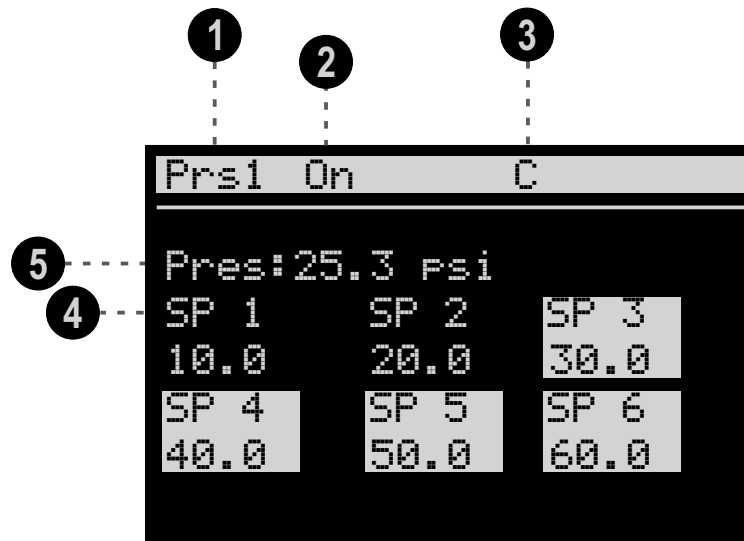

① — Pressure switch on display Prs1, Prs2 or Prs3.

② — On - turned on;
Off - turned off.

③ — Operation mode:
C: compression;
D: descompression.

④ — Displays the setpoint for each digital output of the individual pressure switch.

Sets presented with white background indicate that the respective output is active. In this example, output 1 and 2 are off and outputs 3, 4, 5 and 6 are on.

⑤ — Control pressure value.

White background

 Actuated output



Black background

 Output configured but is shut off.

12.SUMMARY SCREEN

12.6. Individual thermostats:

The individual thermostat screens are accessed from the Control Menu.

To toggle between the available pressure switches just navigate using the keys  and .

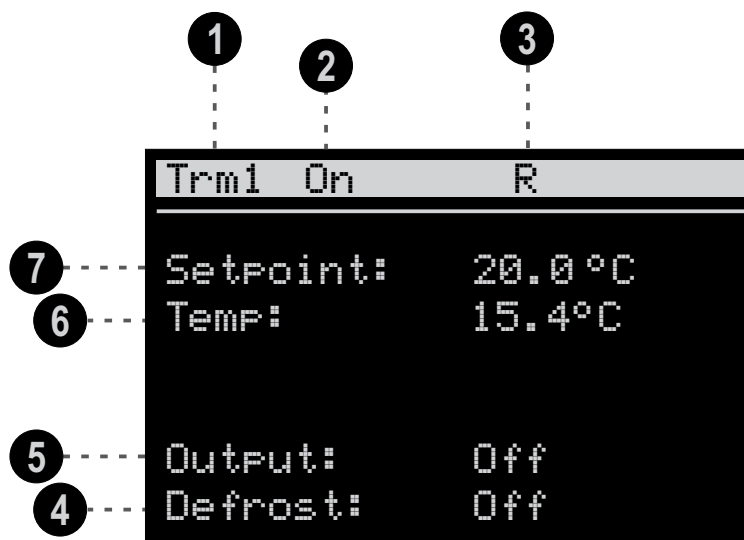

1 – Thermostat on display:
Trm1: Individual thermostat 1;
Trm2: Individual thermostat 2;
Trm3: Individual thermostat 3.

2 – On - turned on;
Off - turned off;
Des - defrost.

3 – Operation mode:
A: heating;
R: refrigeration.

4 – Defrost output status.

5 – Control output status.

6 – Control temperature value.

7 – Temperature setpoint.

12.SUMMARY SCREEN

12.7. Inputs and outputs:

The input and output menu allows you to view the status of all inputs and outputs of the **RCK-862_{plus}** and its configured expansion modules, as well as to check their function.

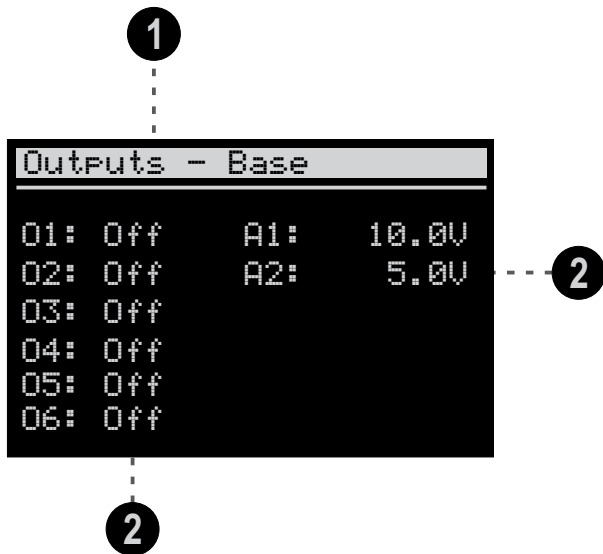

1 — Indicates which equipment is being viewed.

2 — Indicates the status or value of the output.

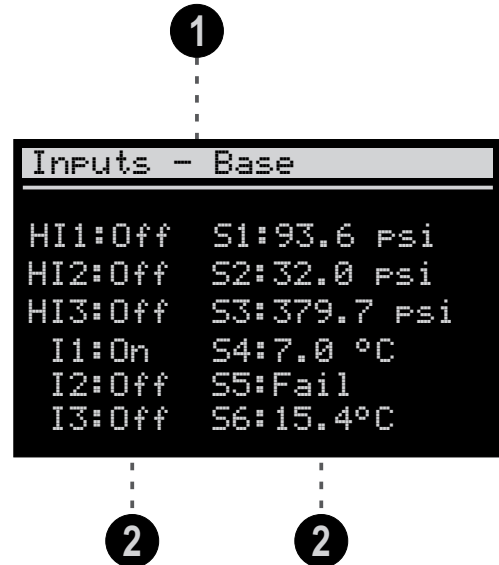

1 — Indicates which equipment and item are being viewed.

2 — Indicates the status or value of the input.

To see which function is assigned to a particular output or input, press **ESC** navigate to the desired item using the keys **↑** and **↓** press **ESC** again.

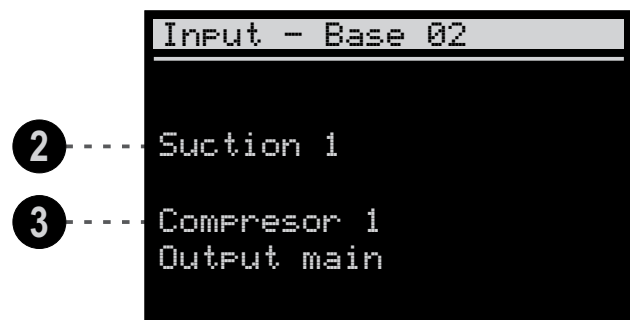
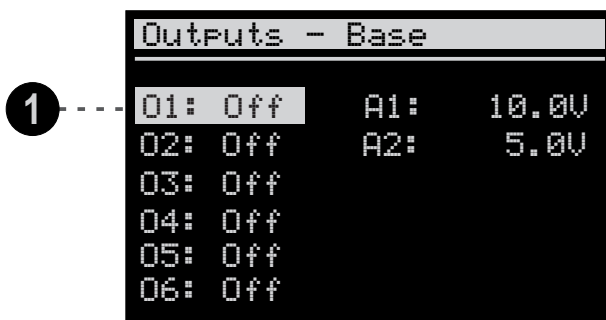

1 — Indicates the selected item.

2 — Indicates the connected pressure switch.

3 — Indicates the function of the selected item.

12.SUMMARY SCREEN

12.8. Auxiliary inputs:

The auxiliary inputs menu allows viewing the current status of all auxiliary digital inputs of the **RCK-862_{plus}**, as well as checking their functions.

To check which function is assigned to a given input, navigate to the desired item using the **↑** and **↓** keys and press **SET**.

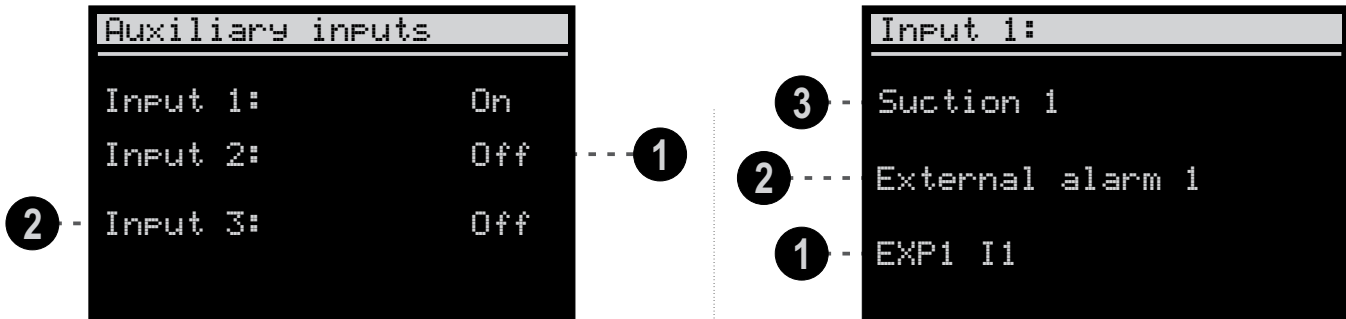

① — Indicates the status of the digital input.

② — Indicates the auxiliary input number.

① — Address input.

② — Input function.

③ — Link use.

12.9. Alarm outputs:

The alarm outputs menu allows you to view the current state of the alarm outputs of the **RCK-862_{plus}**, as well as check their function.

To visualize which function is assigned to a given output, navigate to the desired item using the **↑** and **↓** keys and press **SET**.

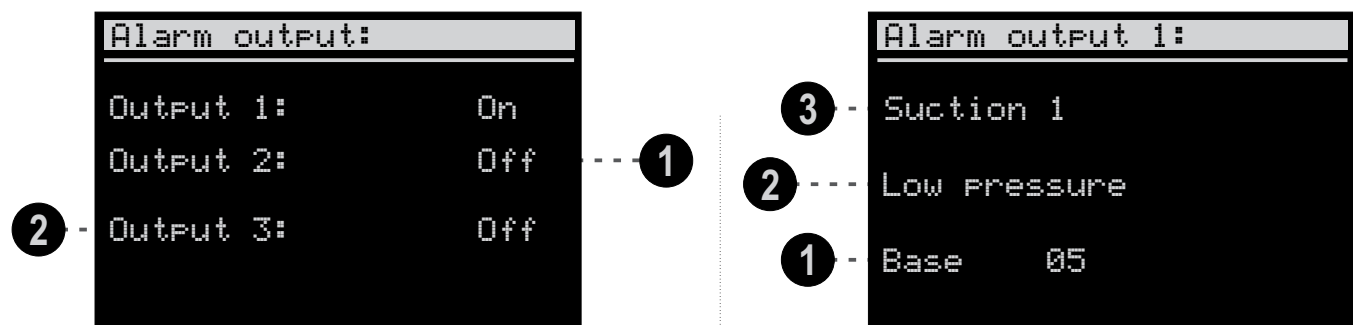

① — Indicates the status of the digital output.

② — Indicates the alarm output number.

① — Address input



② — Input function.

③ — Link use.

12.SUMMARY SCREEN

12.10. Compressor protection thermostats:

Thermostat information is accessed from the Control Menu.

To toggle between the available compressors just navigate using the keys  and .

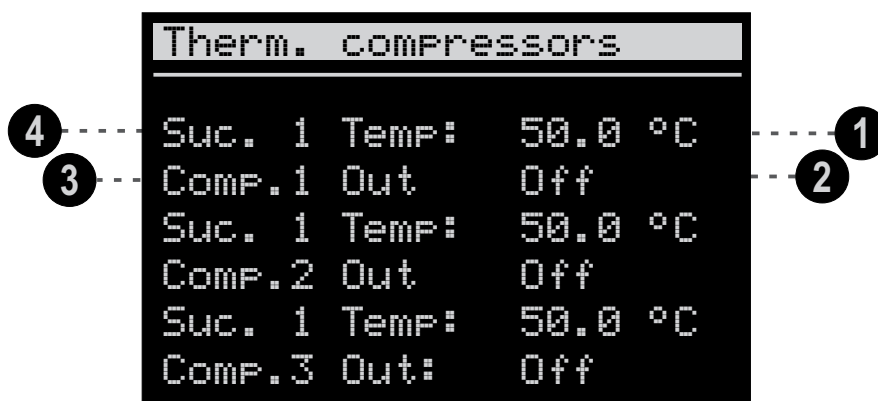

1 — Compressor temperature.

3 — Compressor reference.

2 — Protection output status.

4 — Suction line.

12.11. Pump control:

It allows viewing the status of the outputs of the sets of rotation outputs.

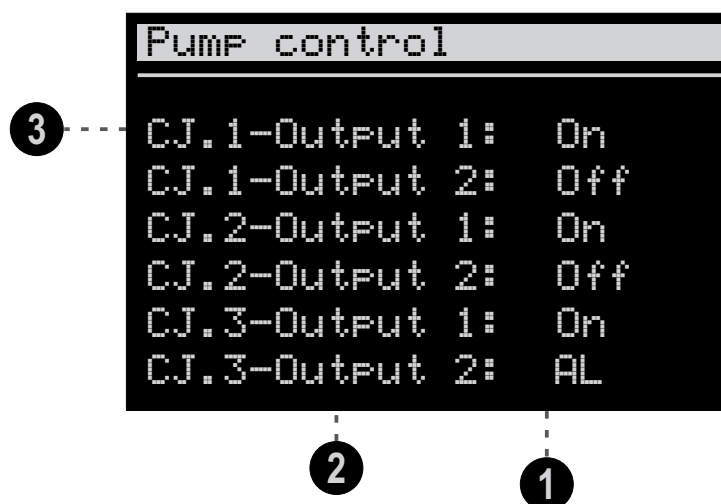

1 — Indicates output status
On: Output on
Off: Output off
AL: Output in alarm

3 — Indicates the set to which the output belongs.

2 — Indicates the output index.

13. CONTROL MENU

The Control Menu is accessible by pressing the  key, has settings and commands for easy access to the operations of the **RCK-862_{plus}**.

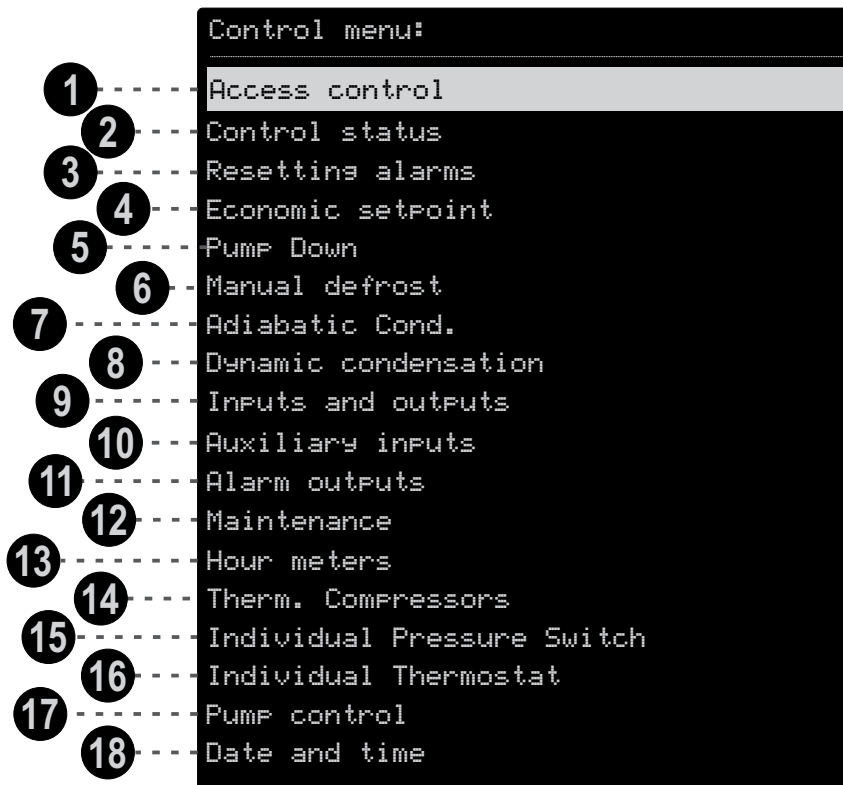

- 1** — **Access control:**
According to the access level, the user can take different action on the **RCK-862_{plus}**. You can adjust 3 access levels:
- Viewer:
Standard mode, there is no need to enter code.
- Technical:
Allows you to make changes to some system parameters.
Technical level is activated by entering code 123.
- Administrator:
Allows you to make changes to all system parameters (normally used when performing the initial system configuration).
Administrator level is activated by entering code 717.
In an invalid code is entered or the **RCK-862_{plus}** is idle for 15 minutes, it automatically returns to Viewer mode.
- 2** — **Control status:**
You can turn the system control on or off **RCK-862_{plus}** only monitors the system but without taking any action.
Note: Changing some functions such as downloading presets requires that the controller be turned off.
Resetting alarms:
Reset the pressure switches in manual or automatic reset condition. Once the resetting is done, this will be recorded in the alarm history.
- 3** — **Economic setpoint:**
Activates the economic setpoint for each group of pressure switches.
PUMP Down:
Activates the Pump Down function for each group of pressure switches.
- 4** — **Manual defrost:**
Activates or deactivates the defrost process manually.
Adiabatic Condensation:
Enables and disables adiabatic condensation logic for each discharge pressure switch.
- 5** — **Dynamic Condensation:**
Enables and disables dynamic condensation logic for each discharge pressure switch.
- 6** — **Inputs and outputs:**
A summary of the **RCK-862_{plus}** inputs and outputs is displayed, indicating the sensor reading value, the status of the digital inputs and control outputs.
- 7** — **Auxiliary inputs:**
It displays the status of the configured auxiliary inputs.
- 8** — **Alarm outputs:**
View the status of configured alarm outputs.
- 9** — **Maintenance:**
Compressors or fans are viewed and selected to enter maintenance mode. When the equipment is in the maintenance state, it remains off.
- 10** — **Hour meters:**
Indicates the number of hours that each compressor or fan has remained in operation.
- 11** — **Compressor protection thermostat:**
View of compressor protection thermostats.
- 12** — **Individual pressure switch:**
View of the summary screens of the individual pressure switches.
- 13** — **Individual thermostat:**
View of the summary screens of the individual pressure switches.
- 14** — **PUMP control:**
View suction line pump control information.
- 15** — **Date and time:**
Adjusts the current date and time. This field is important for alarm and logic records that use a clock.

14. REFRIGERATION GROUP

14.1 Control suction:

RCK-862 plus allows links to be made between suction and discharge lines. These links are formed by creating groups, which are sets of suction and discharge lines. Some commands via menu and digital inputs can be assigned to groups, in addition, alarms that occur on the discharge line act on the suction lines of the same group, turning off compressors. Discharge lines are fixed and belong to groups of the same index, discharge 1 to group 1, discharge 2 to group 2 and discharge 3 to group 3.

Examples of groups:

Two groups with one suction and one discharge each:

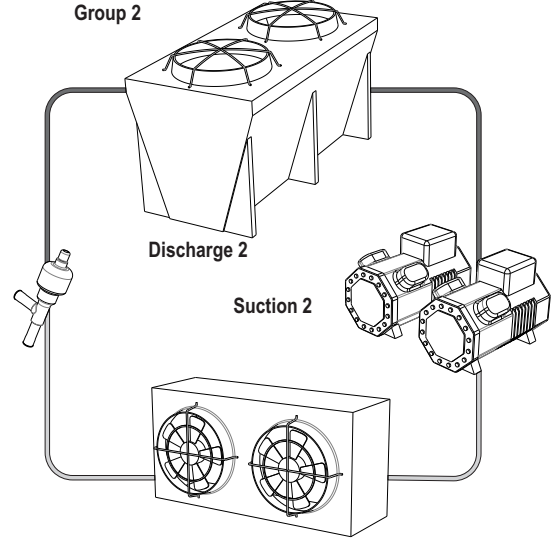
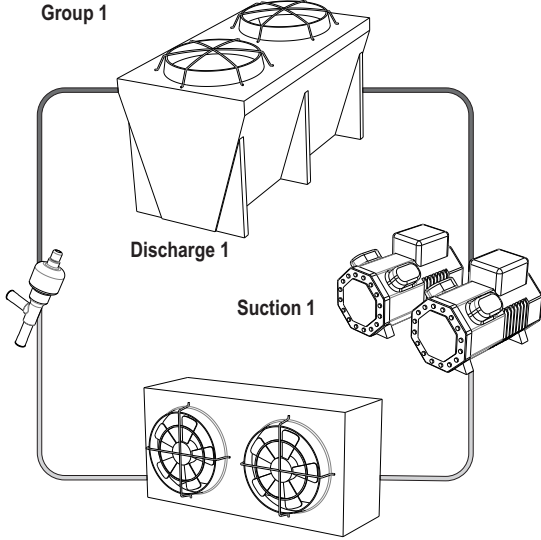

- 1.1.2 Number of suction pressure switches = 2
- 1.1.3 Number of discharge pressure switches = 2
- 1.1.5 Suction group 1 = Group 1
- 1.1.6 Suction group 2 = Group 2
- 1.1.8 Group 1 cooling fluid = R404A
- 1.1.9 Group 2 cooling fluid = R410A

Group 1 with two suctions and one discharge and group 2 with one suction and one discharge:

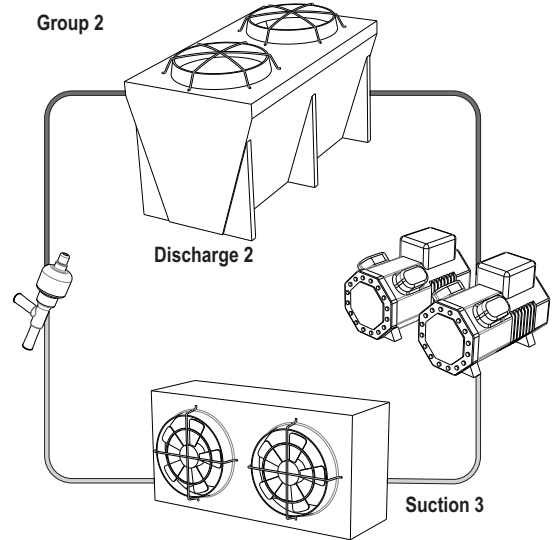
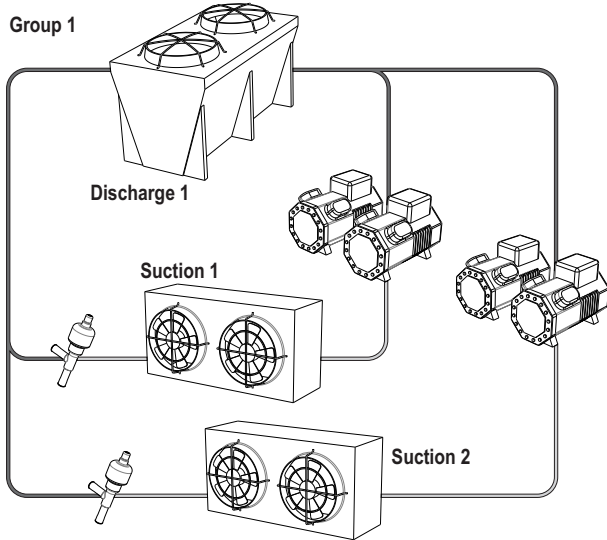

- 1.1.2 Number of suction pressure switches = 3
- 1.1.3 Number of discharge pressure switches = 2
- 1.1.5 Suction group 1 = Group 1
- 1.1.6 Suction group 2 = Group 1
- 1.1.7 Suction Group 3 = Group 2
- 1.1.8 Group 1 cooling fluid = R404A
- 1.1.9 Group 2 cooling fluid = R410A

14. REFRIGERATION GROUP

In addition to the link created by the groups, it is possible to enable synchronism between two suction lines. If the synchronism between suction 1 and 2 is enabled (1.1.28). Suction 2 is forced to operate at the minimum capacity condition before the first compressor of suction 1 starts. In case of an alarm stop on suction 2, suction 1 is also switched off. The same is true for suction 1 and 3 (1.1.27) and suction 2 and 3 (1.1.28).

Application example:

Circuit in cascade configuration with one group operating at low and medium pressure and the other at high. Suction 3 must start before suction 1 or 2 and alarms that turn off suction 3 compressors act on the 3 lines.

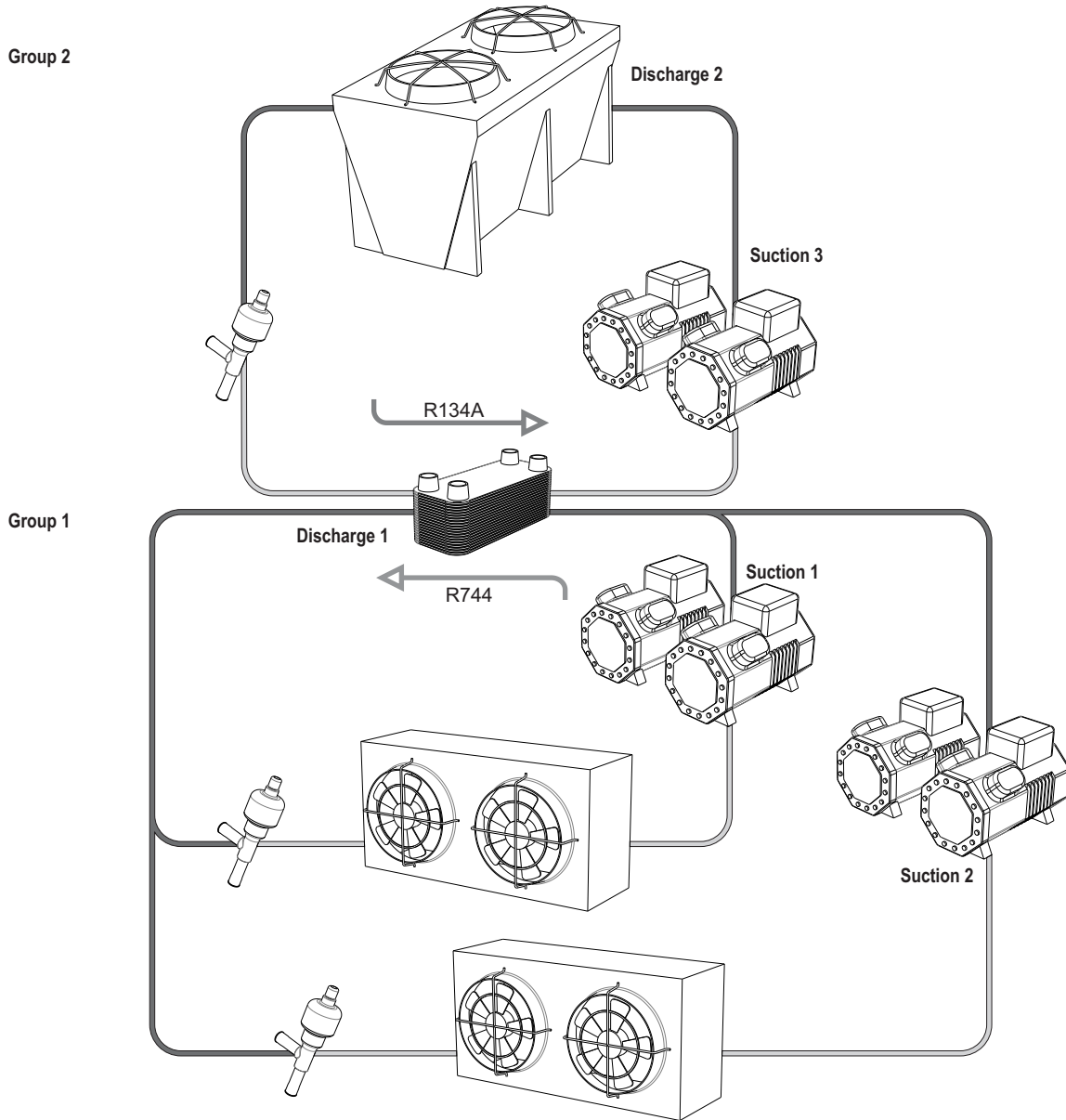

- 1.1.2 Number of suction pressure switches = 3
- 1.1.3 Number of discharge pressure switches = 2
- 1.1.5 Suction group 1 = Group 1
- 1.1.6 Suction group 2 = Group 1
- 1.1.7 Suction Group 3 = Group 2
- 1.1.8 Group 1 cooling fluid = R744
- 1.1.9 Group 2 cooling fluid = R134A
- 1.1.27 Synchronization between suction 1 and suction 3 = Yes
- 1.1.28 Synchronization between suction 2 and suction 3 = Yes

15. SUCTION CONTROLS

15.1 Suction Control:

The suction control parameters are set in the following menu: **Main menu → 1.Functions Settings → 2.Suction.**

Compressor control is linked with a suction pressure switch. The **RCK-862 plus** allows the control of up to 3 suction pressure switches with up to 6 compressors each. The digital outputs indicated as O1, O2...O6, are in charge of the on-off control (On/Off) of compressors and unloaders valves, while the analog outputs, indicated as A1 and A2, emit a 0-10V signal for frequency inverters or other devices. The **RCK-862 plus** controls up to three unloader valves per compressor, having a Control Mode for variable compressors such as the Bitzer CR11.

Note: Alarms on the discharge pressure switches can also act on the suction compressors.

15.2 Compressor modulation On/Off:

Each compressor manufacturer has its own way of controlling capacities in its compressors. The most common compressors have two stages of operation: on or off. In this case, on/off modulation is used. When there are compressors with the possibility of regulating their capacity by means of actuations of step-type unloaders, the type is selected according to the options below:

On/Off (On / Off) - Compressor that uses only one digital output (relay) for its actuation.

On/Off 50 | 100 - A main output and an auxiliary output are linked for 3-stage compressor control.

On/Off 33 | 66 | 100 - A main output and 2 auxiliary outputs are linked for 4-stage compressor control.

On/Off 50 | 75 | 100 - A main output and 2 auxiliary outputs are linked for 4-stage compressor control.

On/Off 25 | 50 | 75 | 100 - One main output and 3 auxiliary outputs are linked for 5-stage compressor control.

An activation mode is defined (1 . 2 . 1 . 28 - (33)) to determine the sequence of operation of the control outputs according to the construction of the compressor and connected with the modulation of the On/Off compressors.

The main menu output, the first to be actuated and the last to be shutdown, is normally used to drive the compressor motor. While the auxiliary outputs are normally used to start or stop, an unloader valve is used for regulating the compressor capacity.

The **RCK-862 plus** has 3 activation modes as shown in the table below:

Incremental Mode					Unloader Mode					Selective Mode				
Modulation ON/OFF 50 100					Modulation ON/OFF 50 100					Modulation ON/OFF 50 100				
Capacity	Main	Aux 1	Aux 2	Aux 3	Capacity	Main	Aux 1	Aux 2	Aux 3	Capacity	Main	Aux 1	Aux 2	Aux 3
Off	○	○	-	-	Off	○	○	-	-	Off	○	○	-	-
50%	●	○	-	-	50%	●	●	-	-	50%	●	●	-	-
100%	●	●	-	-	100%	●	○	-	-	100%	●	○	-	-
Modulation ON/OFF 33 66 100					Modulation ON/OFF 33 66 100					Modulation ON/OFF 33 66 100				
Capacity	Main	Aux 1	Aux 2	Aux 3	Capacity	Main	Aux 1	Aux 2	Aux 3	Capacity	Main	Aux 1	Aux 2	Aux 3
Off	○	○	○	-	Off	○	○	○	-	Off	○	○	○	-
33%	●	○	○	-	33%	●	●	●	-	33%	●	●	○	-
66%	●	●	○	-	66%	●	●	○	-	66%	●	○	●	-
100%	●	●	●	-	100%	●	○	○	-	100%	●	○	○	-
Modulation ON/OFF 50 75 100					Modulation ON/OFF 50 75 100					Modulation ON/OFF 50 75 100				
Capacity	Main	Aux 1	Aux 2	Aux 3	Capacity	Main	Aux 1	Aux 2	Aux 3	Capacity	Main	Aux 1	Aux 2	Aux 3
Off	○	○	○	-	Off	○	○	○	-	Off	○	○	○	-
50%	●	○	○	-	50%	●	●	●	-	50%	●	●	○	-
75%	●	●	○	-	75%	●	●	○	-	75%	●	○	●	-
100%	●	●	●	-	100%	●	○	○	-	100%	●	○	○	-
Modulation ON/OFF 25 50 75 100					Modulation ON/OFF 25 50 75 100					Modulation ON/OFF 25 50 75 100				
Capacity	Main	Aux 1	Aux 2	Aux 3	Capacity	Main	Aux 1	Aux 2	Aux 3	Capacity	Main	Aux 1	Aux 2	Aux 3
Off	○	○	○	○	Off	○	○	○	○	Off	○	○	○	○
25%	●	○	○	○	25%	●	●	●	●	25%	●	●	○	○
50%	●	●	○	○	50%	●	●	●	○	50%	●	○	●	○
75%	●	●	●	○	75%	●	●	○	○	75%	●	○	○	●
100%	●	●	●	●	100%	●	○	○	○	100%	●	○	○	○

Key:
 ● - Output on
 ○ - Output off

Example: For a compressor with two unloaders where each valve removes 33.3% of the compressor capacity, you can select the compressor modulation as On/Off 33 | 66 | 100 (parameter 1 . 2 . x . 22 - (27)). An output is defined for the compressor motor, associated with the main output (1 . 2 . x . 37) and two auxiliary outputs for the unloader valves (1 . 2 . x . 38 and 1 . 2 . x . 39). The behavior of the auxiliary outputs is defined by the parameter "Compressor activation mode" (1 . 2 . x . 28 - (33)).

In "Incremental mode" when only the main compressor output is activated, the controller assumes that the compressor works at 33.3% of its capacity. When actuating auxiliary output 1 it will increase the capacity to 66.6% and when actuating auxiliary output 2 to 100% of the compressor's nominal capacity. In "unloader mode" when the compressor output is actuated, the controller assumes that the compressor works at 100% of its capacity. When actuating auxiliary output 1, the activated capacity will be 66.6% and when the second auxiliary output is actuated, the activated capacity will be 33.3% of the nominal capacity.

In "Selective mode" when only the main compressor output is actuated, the controller assumes that the compressor works at 100% of its capacity. When actuating auxiliary output 2, there is 66.6% and when auxiliary output 2 is switched off and on, auxiliary output 1 has 33.3% of the compressor's nominal capacity.

15.SUCTION CONTROLS

15.3 Modulation of Variable Capacity Compressors (VCC):

Variable Capacity Compressors (VCC) are compressors controlled by means of an analog output (VCC-Analog) or by means of fast-acting digital outputs (VCC-Digital).

Only compressor 1 of each suction pressure switch can be configured as VCC and when operating together with ON / OFF compressors it is the first to be actuated and the last to be shutdown.

15.3.1 VCC-Analog:

To control an analog variable capacity compressor, a 0-10V analog output and optionally a digital Start/Stop output are used. The analog output selected in function 1.2.x.36 is configured in menu 1.10 according to the characteristics of the device to be controlled (frequency inverter or digital control module). The start of modulation of the output (compressor start) occurs when the difference between the measured pressure and the setpoint is equivalent to or greater than the configured minimum value. If a starting value of the analog output (1.10.x.3) is configured, the **RCK-862 plus** applies this value during the starting time (1.2.x.67)

15.3.2 VCC-Digital:

To control a compressor of the VCC-Digital type, it is necessary to configure a digital output for motor activation and one or more fast-acting outputs (SSR) for actuation of capacity modulation valves. During compressor operation, only one valve is modulated while the others remain on or off. The choice of which valve should be modulated is made automatically considering the smallest number of actuations between the valves of the same compressor, thus increasing the life span of the assembly.

The compressor starts when the required capacity is greater than the value configured in VCC-Digital: Minimum capacity (1.2.x.69) and remains operating without load during the time configured in VCC: Starting time (1.2.x.67).

The Algorithm present in the **RCK-862 plus** automatically determines when the auxiliary outputs are to be actuated. If it is of interest to carry out the control of the valves at fixed time intervals, select the desired period in the parameter VCC-Digital: Control period (1.2.x.70).

Each digital compressor manufacturer determines limitations for the minimum activation time of the modulation valves, which can be configured in VCC-Digital: Minimum valve activation time (1.2.x.71).

The maximum time that the compressor can operate without load can be configured in VCC-Digital: Maximum time without load (1.2.x.72), when this time elapses the compressor actuates one of its modulation valves (increasing the flow of refrigerant in the compressor) for the same time configured in (1.2.x.72). A compressor start time can be configured, according to:

Note: Re-balance a shorter starting time than the maximum time without a load (1.2.x.72).

The **RCK-862 plus** allows the control of several variations of digital compressors, allowing the modulation of compressors from one to three auxiliary control valves. For the correct selection, it is necessary to evaluate which configuration meets the compressor characteristics, according to:

VCC-Digital 10-100 1V: One main output for compressor activation and one digital output (SSR) for modulation of auxiliary valves. The main output is considered to represent 0% of the compressor capacity.

VCC-Digital 10-100 2V: One main output for compressor activation and two digital outputs (SSR) for modulation of two auxiliary valves. The main output is considered to represent 0% of the compressor capacity.

VCC-Digital 10-100 3V: One main output for compressor activation and three digital outputs (SSR) for modulation of three auxiliary valves. The main output is considered to represent 0% of the compressor capacity.

VCC-Digital 33-100 1V: One main output for compressor activation and one digital output (SSR) for modulation of auxiliary valves. The main output is considered to represent 33% of the compressor capacity.

VCC-Digital 33-100 2V: One main output for compressor activation and two digital outputs (SSR) for modulation of two auxiliary valves. The main output is considered to represent 33% of the compressor capacity.

VCC-Digital 50-100 1V: One main output for compressor activation and one digital output (SSR) for modulation of auxiliary valves. The main output is considered to represent 50% of the compressor capacity.

The following table illustrates the behavior of the outputs in relation to the capacity required by the compressor without considering the rotation of the outputs.

VCC-Digital 10-100 2V_B: a main output for activating the compressor, a digital output (SSR) for modulating a valve, which takes up 50% of the compressor's capacity and a digital output for the unloader, corresponding to 50% of the compressor's capacity as well. The main output is assumed to represent 0% of the compressor's capacity.

VCC-Digital 10-100 3V_B: a main output for activating the compressor, a digital output (SSR) for modulating a valve, which takes up 33% of the compressor's capacity. Also, there are two digital outputs for the unloader corresponding to 33% of the compressor's capacity as well. The main output is assumed to represent 0% of the compressor's capacity.

15.SUCTION CONTROLS

Modulation off VCC-Digital compressors

Modulation VCC-Digital 10-100 1V					Modulation VCC-Digital 33-100 1V					Modulation VCC-Digital 50-100 1V				
Capacity	Main	Aux 1	Aux 2	Aux 3	Capacity	Main	Aux 1	Aux 2	Aux 3	Capacity	Main	Aux 1	Aux 2	Aux 3
Off	○	○	-	-	Off	○	○	-	-	Off	○	○	-	-
10-100%	●	◐	-	-	33-100%	●	◐	-	-	50-100%	●	◐	-	-
>100%	●	○	-	-	>100%	●	○	-	-	>100%	●	○	-	-

Modulation VCC-Digital 10-100 2V					Modulation VCC-Digital 33-100 2V					Modulation VCC-Digital 10-100 3V				
Capacity	Main	Aux 1	Aux 2	Aux 3	Capacity	Main	Aux 1	Aux 2	Aux 3	Capacity	Main	Aux 1	Aux 2	Aux 3
Off	○	○	○	-	Off	○	○	○	-	Off	○	○	○	○
10-50%	●	◐	●	-	33%	●	◐	●	-	10-33%	●	◐	●	●
50-100%	●	○	◐	-	66%	●	○	◐	-	33-66%	●	○	◐	●
>100%	●	○	○	-	100%	●	○	○	-	66-100%	●	○	○	◐
										>100%	●	○	○	○

Modulation VCC-Digital 10-100 2V_B					Modulation VCC-Digital 10-100 3V_B				
Capacity	Main	Aux 1	Aux 2	Aux 3	Capacity	Main	Aux 1	Aux 2	Aux 3
Off	○	○	○	-	Off	○	○	○	○
10-50%	●	◐	●	-	10-33%	●	◐	●	●
50-100%	●	◐	○	-	33-66%	●	◐	○	●
>100%	●	○	○	-	66-100%	●	◐	○	○
					>100%	●	○	○	○

Key
 ● - Output on
 ○ - Output off
 ◐ - Modulated output

 **Note:** It is assumed that when a valve is activated, the controlled element operates without load and the compressor capacity is reduced.

15.4 Control Modes:

Each suction pressure switch can be programmed, in parameter 1.2.x.1, to operate according to one of the Control Modes: Linear Mode, Rotation Mode, Dead Zone Mode, Dead Zone Mode with rotation and Progressive Algorithm Mode.

15.4.1 Linear Mode:

Linear mode is applied when using compressors of the same capacity, combined or not with a compressor with proportional modulation (inverter). Compressors and their unloader valves are activated (if configured) sequentially and at equal pressure intervals. It follows the ascending order according to its nomenclature and shutdown.

15.4.1.1 Linear mode connected only with digital outputs - ON/OFF compressors + Unloaders

The Linear control mode, when it has only digital outputs connected, commands the actuation and shutdown of each compressor sequentially and with pressure intervals of the same magnitude (step). The **RCK-862 plus** uses a setpoint value and pressure hysteresis to control the suction of the compressors. If the compressors have unloaders valves (auxiliary outputs), the logic of actuation and shutdown can be chosen according to parameters 1.2.x.34 and 1.2.x.35

The digital outputs are linked with the compressors in the **Main Menu** → **1.Function settings** → **1.2 Suction**. The **RCK-862 plus** defines the actuation and shutdown points according to the hysteresis value and the number of compressors configured in the suction, according to the "step" variable defined below:

$$\text{Step} = \frac{\text{Digital outputs actuation step}}{\text{Number of outputs}}$$

Actuation output pressure value for output "N"
 Actuation = Setpoint + (N x Step)
Shutdown output pressure value of output "N"
 Actuation = Setpoint + (N - 1 x Step)

15.SUCTION CONTROLS

Example: Linear control linked only with ON-OFF compressors

ON/OFF compressors only

When using on / off compressors (ON / OFF), each compressor is associated with only one output, so the Step is equal to hysteresis by dividing the number of compressors

- | | |
|---|---|
| 1.2.x.1 Control mode: Linear | 1.2.x.39 Compressor2 modulation: ON/OFF |
| 1.2.x.3 Setpoint: 25 psi | 1.2.x.40 Compressor3 modulation: ON/OFF |
| 1.2.x.5 On/Off Hysteresis: 6 psi | 1.2.x.41 Compressor4 modulation: ON/OFF |
| 1.2.x.31 Number of compressors: 6 | 1.2.x.42 Compressor5 modulation: ON/OFF |
| 1.2.x.38 Compressor1 modulation: ON/OFF | 1.2.x.43 Compressor6 modulation: ON/OFF |

In this case, each compressor is associated with a digital output and the Step is defined as $6/6 = 1$ psi

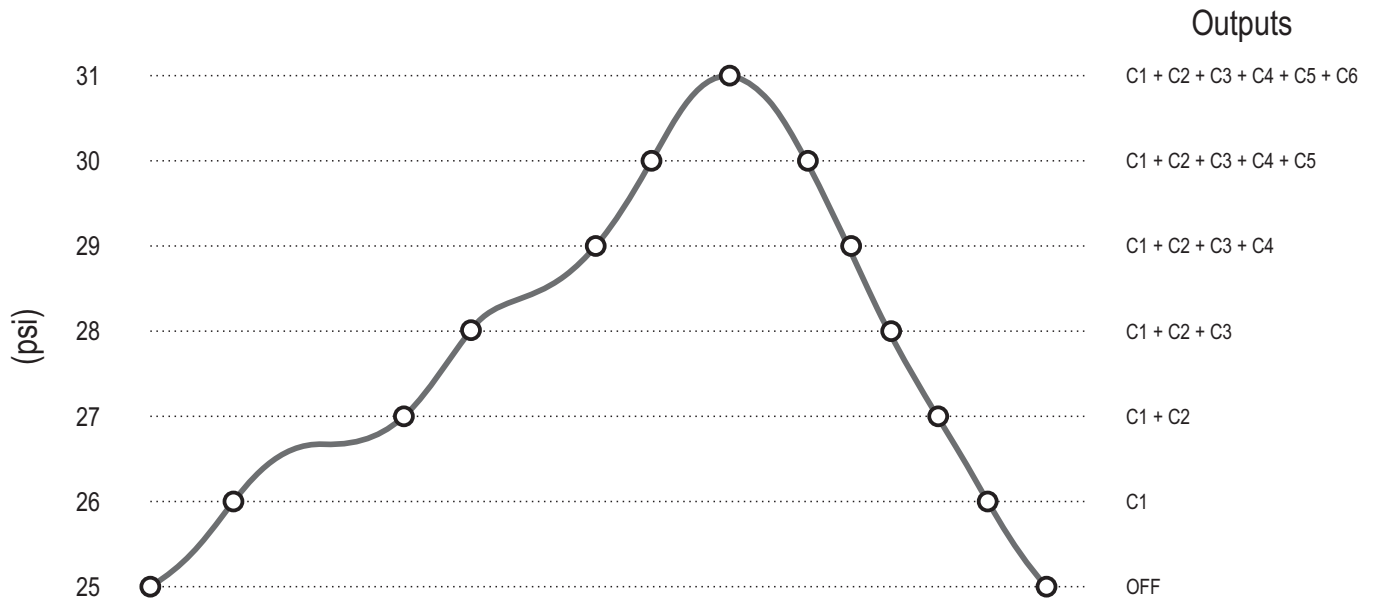

Example: Linear control linked with digital outputs from compressors with unloaders

On/Off compressors with unloaders.

In the compressors that use the unloader capacity regulation valve, the logic for actuating and shutting down the main relays and auxiliary unloader valves is chosen according to parameters 1.2.x.34 - Sequence of actuations and 1.2.x.35 - Sequencing of shutdowns.

- | | |
|---|---|
| 1.2.x.1 Control mode: Linear | 1.2.x.39 Compressor2 modulation: On / Off 50 100 |
| 1.2.x.3 Setpoint: 25 psi | 1.2.x.40 Compressor3 modulation: On / Off 33 66 100 |
| 1.2.x.4 On/Off Hysteresis: 6 psi | 1.2.x.45 Compressor2 activation mode: Incremental |
| 1.2.x.31 Number of compressors: 3 | 1.2.x.46 Compressor3 activation mode: Incremental |
| 1.2.x.38 Compressor1 modulation: ON/OFF | 1.2.x.50 Activation sequence: PPuu |
| | 1.2.x.51 Deactivation sequence: PPuu |

Compressor 1 is of the ON/OFF type and requires only one digital output connected to it. Compressor 2 has an unloader valve, so it is connected to two digital outputs (main and auxiliary 1). Compressor 3 has two unloader valves, so it is connected to three digital outputs (main, auxiliary 1 and auxiliary 2). The total number of digital outputs is six and its step is defined as: $6/6 = 1$ psi.

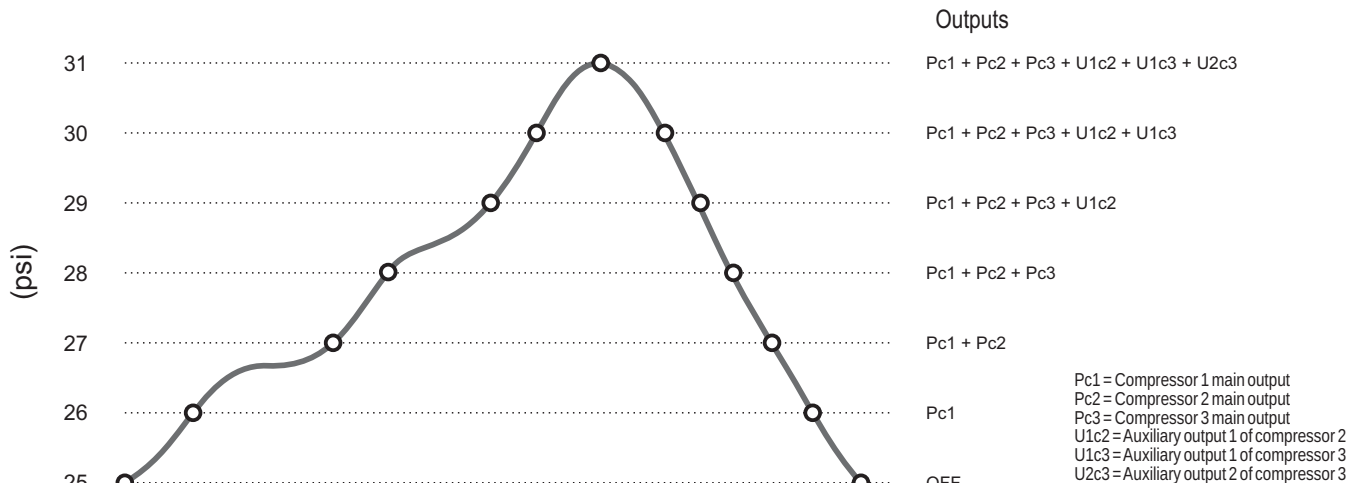

Pc1 = Compressor 1 main output
 Pc2 = Compressor 2 main output
 Pc3 = Compressor 3 main output
 U1c2 = Auxiliary output 1 of compressor 2
 U1c3 = Auxiliary output 1 of compressor 3
 U2c3 = Auxiliary output 2 of compressor 3

15.SUCTION CONTROLS

15.4.1.2 Linear Mode associated with a VCC compressor in conjunction with ON/OFF compressors:

When the VCC compressor, analog or digital, operates together with On / Off compressors - with or without unloaders - the control is done through a setpoint value and two hysteresis. The hysteresis of the VCC compressor (1.2.x.5) corresponds to the pressure range for controlling the output of compressor 1 and the hysteresis of the On / Off compressors (1.2.x.4) corresponds to the control range of the other compressors. The VCC compressor is the first to be actuated and the last to be shutdown. There is a validation time (1.1.x.68) for starting or stopping compressors or unloaders valves when the compressor reaches its upper or lower limit of actuation. For each compressor or unloader actuated or shutdown, the capacity of the VCC compressor is recalculated to compensate for the portion added or removed.

Example:

- 1.2.x.1 Control mode: Linear
- 1.2.x.3 Setpoint: 25 psi
- 1.2.x.5 Hysteresis On/Off: 4psi
- 1.2.x.6 VCC hysteresis: 2psi

- 1.2.x.31 Number of compressors: 3
- 1.2.x.38 Compressor 1 modulation: VCC-Analog
- 1.2.x.39 Compressor 2 modulation = On/Off
- 1.2.x.40 Compressor 3 modulation = On/Off

Compressor 1 (proportional) uses analog output (0-10V), compressors 2 and 3 each use a digital output. The step of the digital outputs is defined as: 4/2 = 2psi.

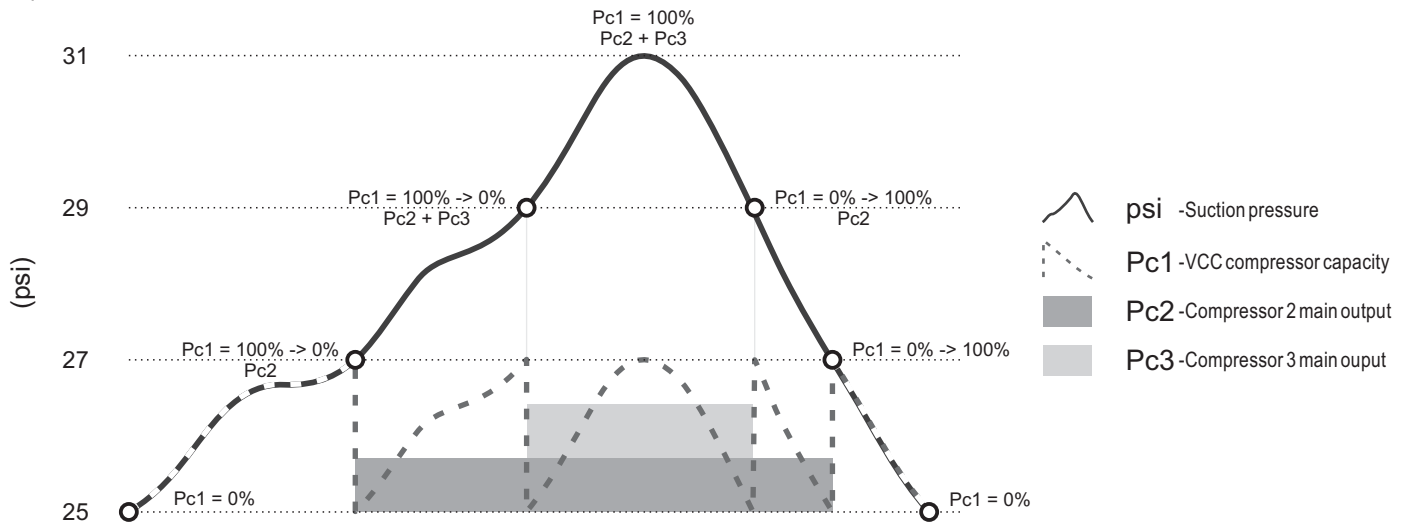

15.4.1.3 Linear mode connected to a VCC-Analog compressor:

The VCC-Analog is used to drive frequency inverters or modules to control compressors that receive a signal between 0-10V. The control uses the parameters of the setpoint value and the hysteresis of the VCC compressor. It is also possible to connect a digital input for the Start-stop output of the VCC compressor.

Example

- 1.2.x.1 Control mode: Linear
- 1.2.x.6 Setpoint: 25 psi
- 1.2.x.6 VCC hysteresis: 6psi
- 1.2.x.31 Number of compressors: 1
- 1.2.x.38 Modulation of compressor 1: VCC-Analog
- 1.2.x.52 Compressor 1 analog output: A1

- 1.2.x.53 Compressor 1 start-stop main output: O1
- 1.2.x.83 VCC: Starting time: 60s
- 1.10.x.2 Minimum value of the analog output: 10%
- 1.10.x.3 Starting value of the analog output: 15%
- 1.10.x.4 Maximum value of the analog output: 100%

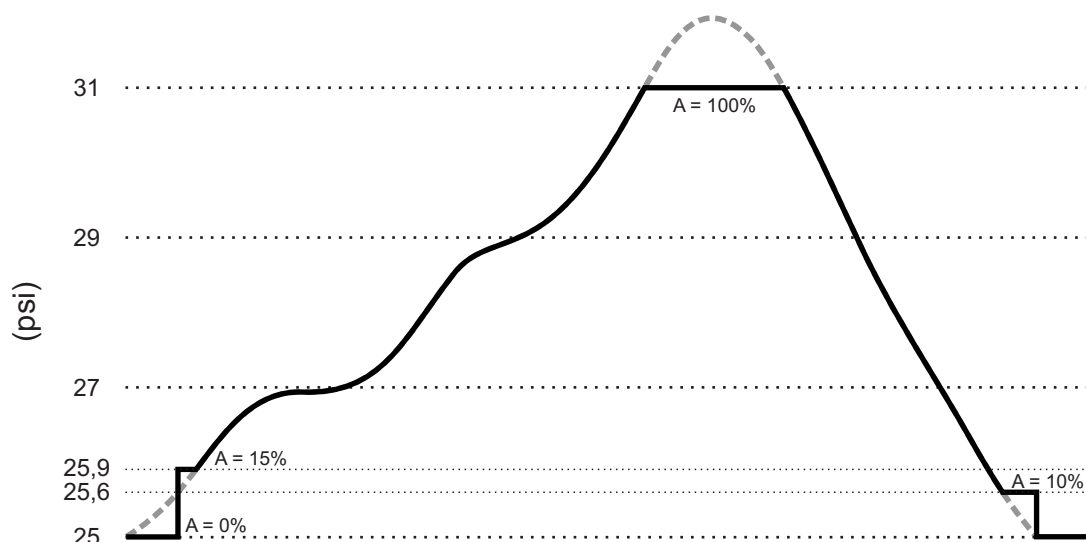

15.SUCTION CONTROLS

15.4.3 Dead zone mode:

Dead band controlling consists of defining a range around the setpoint where the control action is fixed, except for VCC compressors. The control takes different actions in the 3 different operating ranges, above it, inside and below the delimited zone. The dead zone is defined by the parameters Dead Band Lower Differential (1.2.x.8 or 1.2.x.17) and Dead Band Higher Differential (1.2.x.9 or 1.2.x.18). Above the zone, the compressors are activated according to the time set between compressor activations (1.2.x.77).

Within the zone, the number of compressors running is maintained and only the compressor capacity VCC is modulated so that it reaches its minimum value when the control variable is at the lower differential value and its maximum value at the higher differential.

Below the zone, ranges are created where the compressors are turned off based on the time between compressor shutdowns (1.2.x.78) or immediately, if the pressure or temperature reaches ranges further from the setpoint.

Example:

1.2.x.1 Control mode: Dead band

1.2.x.2 Setpoint: 30psi

1.2.x.8 Lower dead zone differential: 10,0psi

1.2.x.9 Upper dead zone differential: 10,0psi

1.2.x.31 Number of compressors: 4

1.2.x.38 Compressor 1 modulation: VCC-Analogic

1.2.x.39 Compressor 2 modulation: On/Off

1.2.x.40 Compressor 3 modulation: On/Off

1.2.x.41 Compressor 4 modulation: On/Off

1.2.x.77 Time between actuations: 30 seconds

1.2.x.78 Time between shutdowns: 60 seconds

Considering the effect of the dead zone, no compressor should be activated until the pressure exceeds 45.0 psi, so compressors 1 to 3 are only activated when the pressure exceeds this value and respecting the time between activations.

If the pressure decreases, entering the dead zone the compressors will remain activated until exceeding the Differential range of the lower dead zone. One compressor is deactivated immediately, and the others are gradually switched off respecting the time between shutdowns. If the pressure drops quickly across the instantaneous shutdown ranges, the compressor is shut down immediately. The step for instantaneous shutdown is defined according to:

Instantaneous shutdown step = Lower dead zone differential / (number of active stages - 1) = 10 / (3-1) = 5

Compressor 3 is shutdown when crossing the lower limit, 20 psi and compressors 1 and 2 are shut down as follows:

Case 1: If the pressure remains within the range of 20.0 and 15.0 psi. Compressor 2 shuts down 60 seconds after compressor 3 and compressor 1 shuts down 60 seconds after compressor 2.

Case 2: If the pressure drops rapidly to the range between 15.0 and 10.0 psi. Compressors 2 and 3 shut down immediately and compressor 1 is shut down 60 seconds later.

Case 3: If the pressure drops quickly below 10.0 psi, all compressors are switched off immediately.

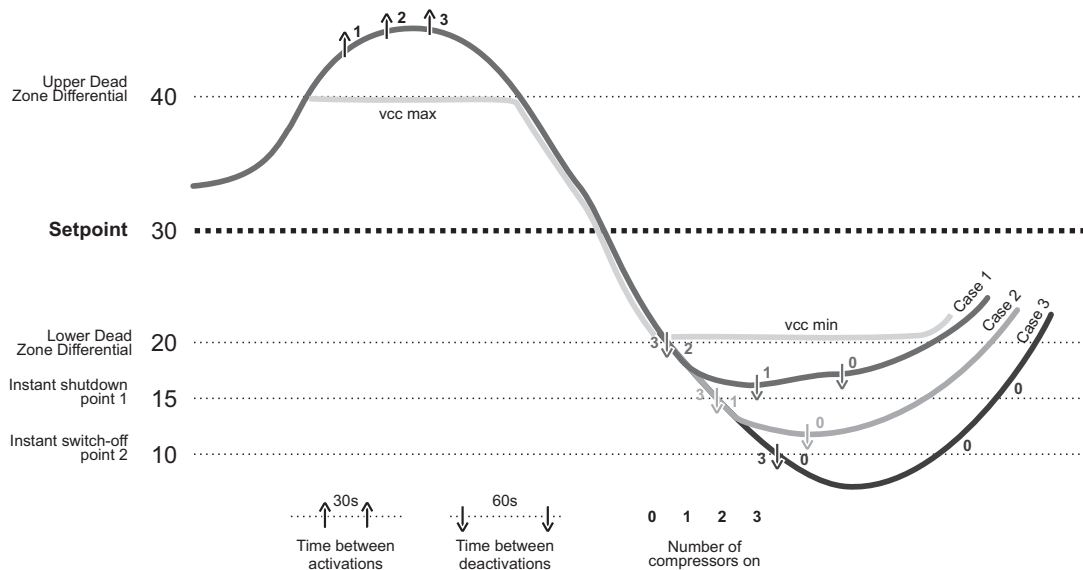

15.4.4 Dead Zone Mode with rotation:

The Dead Zone Control Mode is applied together with the rotation, which is given preference to activate compressors with records of shorter time on and to shutdown compressors with records of longer time on.



Note: The use of Variable Capacity Compressors (VCC) is not allowed in this control mode.

15.SUCTION CONTROLS

15.4.5 Progressive algorithm mode:

The Progressive Algorithm is an ideal control mode for systems that use compressors of different capacities for suction. The Progressive Algorithm considers the capacities of each compressor to supply the thermal demand of the system, seeking to optimize the use of unloader valves, minimizing the number of compressors starts and shutdowns. This mode can work with up to 6 compressors per suction line where one of them can be configured as Variable Capacity Compressor (VCC). When compressor 1 is configured as VCC, it is the first to be activated and the last to be shut off. Progressive Algorithm Mode uses setpoint and a single hysteresis "AP control mode hysteresis".

Application example:

- 1.2.x.1 Control mode: Progressive Algorithm
- 1.2.x.3 Setpoint: 25psi
- 1.2.x.7 AP Control Mode Hysteresis: 10psi
- 1.2.x.31 Number of compressors: 3
- 1.2.x.32 Compressor 1 capacity: 8kW
- 1.2.x.33 Compressor 2 capacity: 12kW

- 1.2.x.34 Compressor 3 capacity: 20kW
- 1.2.x.38 Compressor 1 modulation: On/Off 50 | 100
- 1.2.x.39 Compressor 2 modulation: On/Off 50 | 100
- 1.2.x.40 Compressor 3 modulation: On/Off 50 | 100
- 1.2.x.44 Compressor 1 activation mode: Incremental
- 1.2.x.45 Compressor 2 activation mode: Incremental
- 1.2.x.46 Compressor 3 activation mode: Incremental

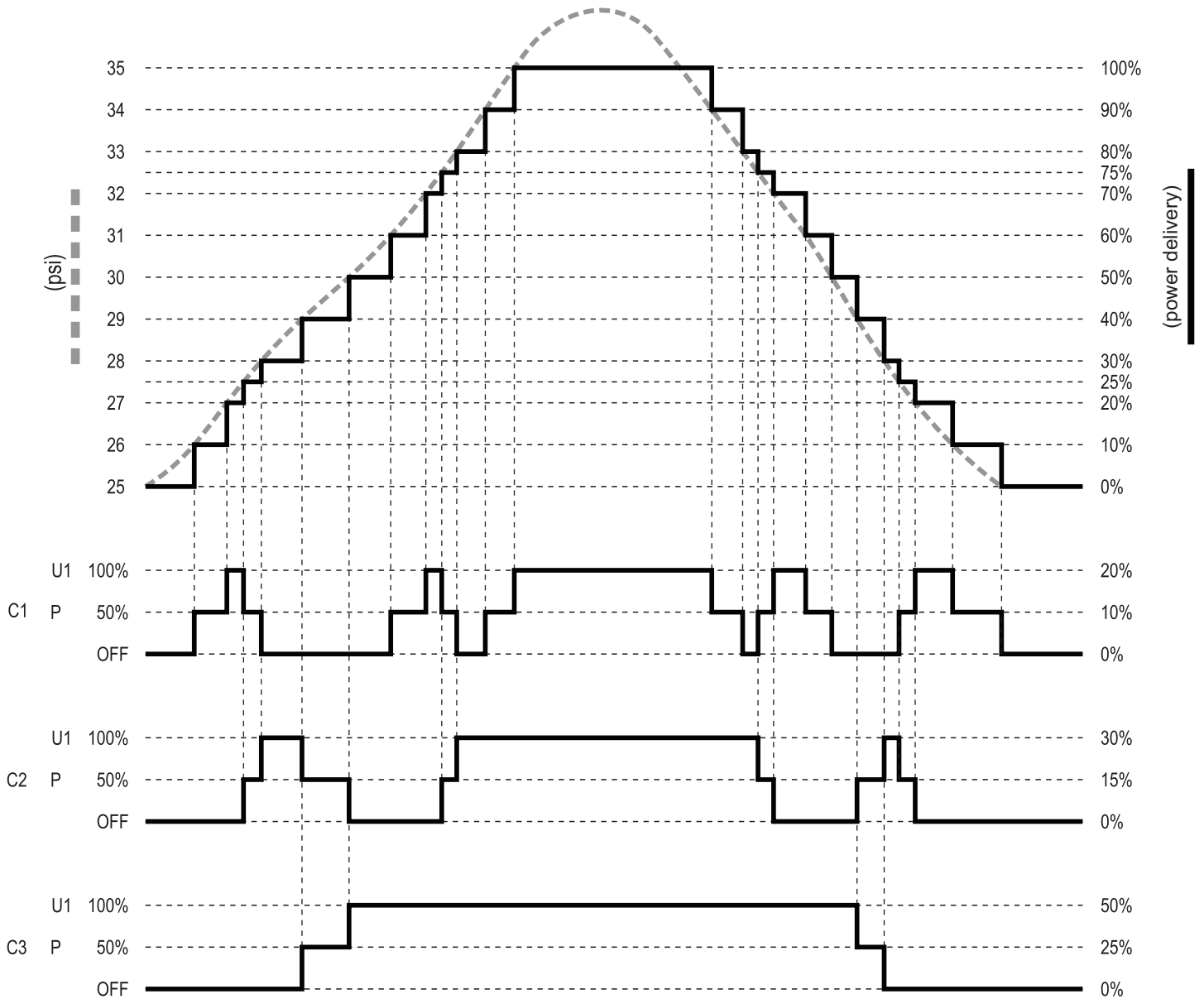

15.SUCTION CONTROLS

15.4.6 Controlling compressors by evaporation temperature:

RCK-862 plus allows the control of compressors to be done by cooling fluid saturation temperature. For this the suction pressure sensor reading converted to temperature is used.

In this type of control, a setpoint and hysteresis configured in temperature are considered (Functions 1.2.x.12 to 1.2.x.20). The pressure reading is only considered for setting alarms and protection.

For the conversion of pressure to evaporation temperature to be done correctly, the refrigerant fluid or the group corresponding to the suction line must be configured (1.1.8 for suction 1, 1.1.9 for suction 2 and 1.1.10 for suction 3).

To prevent the pressure from assuming low values, close to the alarm limit, it is recommended to use the low-pressure shutdown strategy, discussed in the following topic (14.4.9).

15.4.7 Temperature controlling:

RCK-862 plus allows the compressors to be controlled by the temperature of a secondary fluid, in other words, different from the refrigerant in the main Cooling circuit. For this, temperature sensors are used, measuring the temperature of the fluid of interest.

An application example is a chilled water-cooling circuit where, instead of controlling the compressors by the pressure or evaporation temperature of the cooling fluid, it is controlled through the input or output temperature of a heat exchanger.

In this type of control, a setpoint and hysteresis configured in temperature are considered (Functions 1.2.x.12 to 1.2.x.20). The pressure reading is only considered for setting alarms and protection.

It is possible to configure two temperature sensors named "Input temperature sensor" and "Output temperature sensor" and through function 1.2.x.2 it is defined which sensor will be used for control. In the suction alarm menu (1.4.2.x.6 to 1.4.2.x.9) it is possible to set alarm values for low and high temperature of both sensors.

To prevent the pressure from assuming low values, close to the alarm limit, it is recommended to use the low-pressure shutdown strategy, discussed in the following topic (14.4.9).

Note: This type of control is not allowed in a medium or high-pressure suction in a cascade configuration.

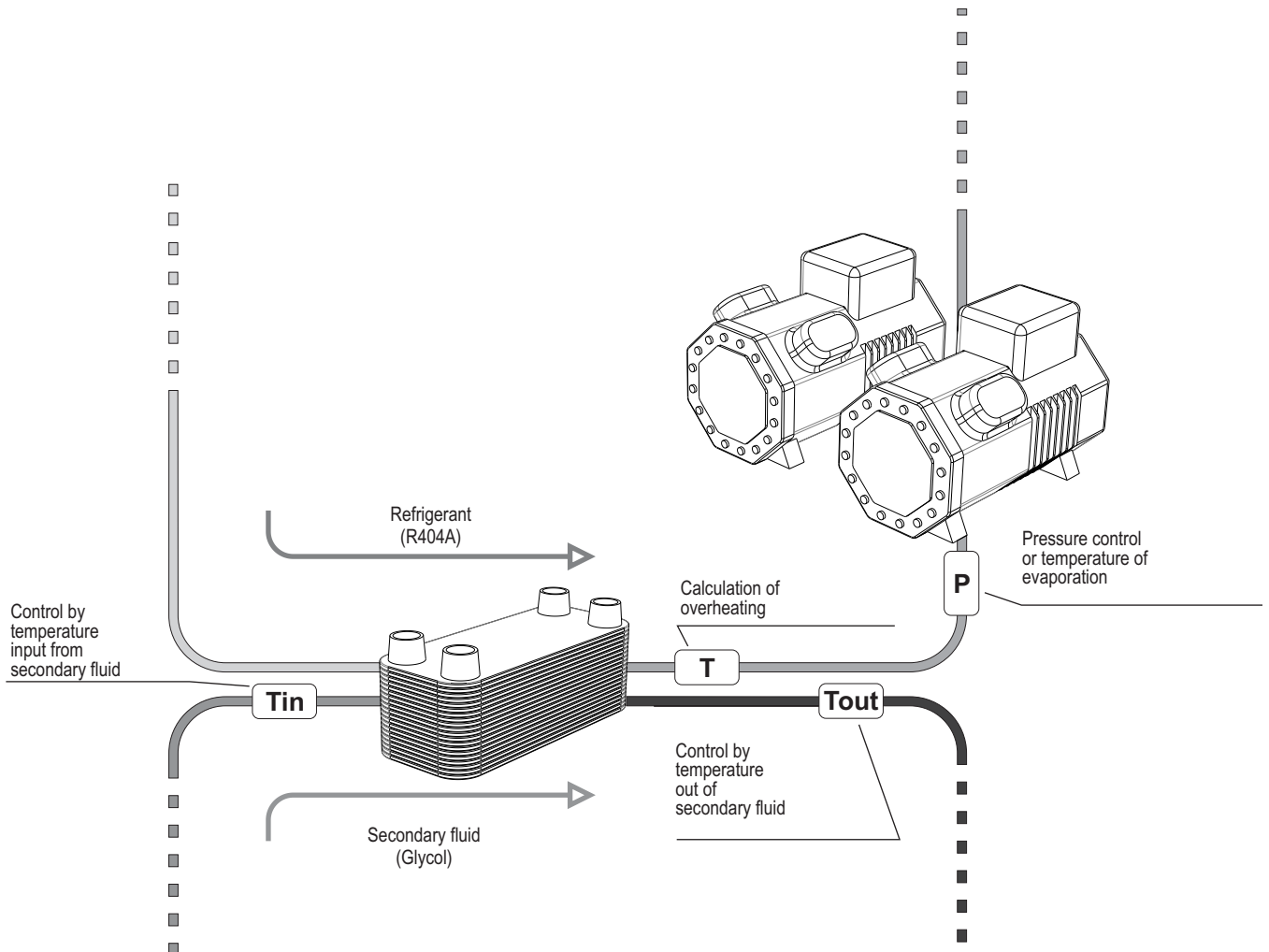

15.SUCTION CONTROLS

15.4.8 Integral action:

In some systems, the control of compressors with only proportional action (Setpoint and hysteresis) tends to present an error in steady state (not reaching the setpoint) or to show oscillatory behavior (excessive pressure variation around the setpoint and high number of compressor start). In these cases, the use of integral action together with proportional control has the objective of keeping the control pressure stable, converging to values close to the setpoint.

Application example:

Proportional-only control

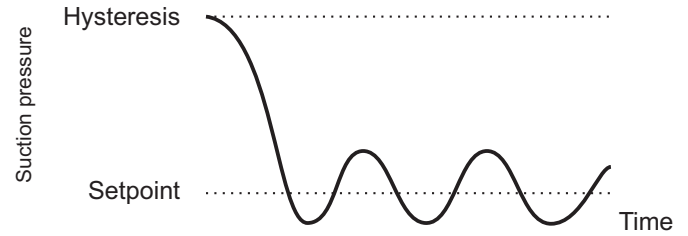
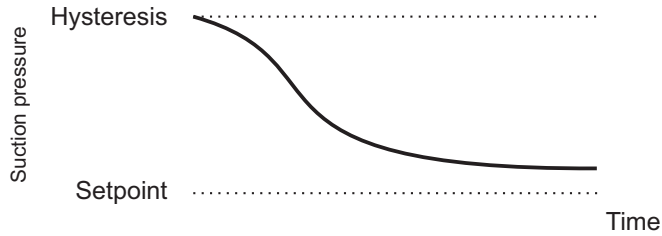

Proportional + Integral Control

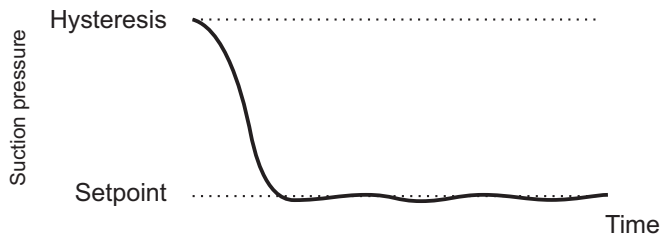

The integral action can be used in all control modes, including those that operate only on the On/Off outputs. To activate the integral action, simply set a value other than parameter Integral time (1 . 2 . x . 9).

The higher the configured value, the slower and more stable the system's behavior.

The lower the configured value, the faster and more oscillatory the behavior is.



Note: The definition of this parameter depends on the capacity of the system and the response speed of its pressure fluctuations. It is suggested to start the tests to define this parameter using the value of 330 seconds.

15.SUCTION CONTROLS

15.4.9 Low pressure shutdown:

Allows you to set a pressure range where the activated capacity of the line is limited in order to prevent the system from reaching low pressures during operation. Its use is recommended when the control variable is not suction pressure.

The shutdown logic acts when the pressure operates within the pressure range between “Low pressure for shutdown” (1.2.x.23) and “Critical pressure for shutdown” (1.2.x.22). When the pressure value reaches this range, the line’s driven capacity (number of compressors) is proportionally reduced as the pressure value decreases, reaching 0 when it reaches the Critical Pressure value.

Example with On/Off compressors:

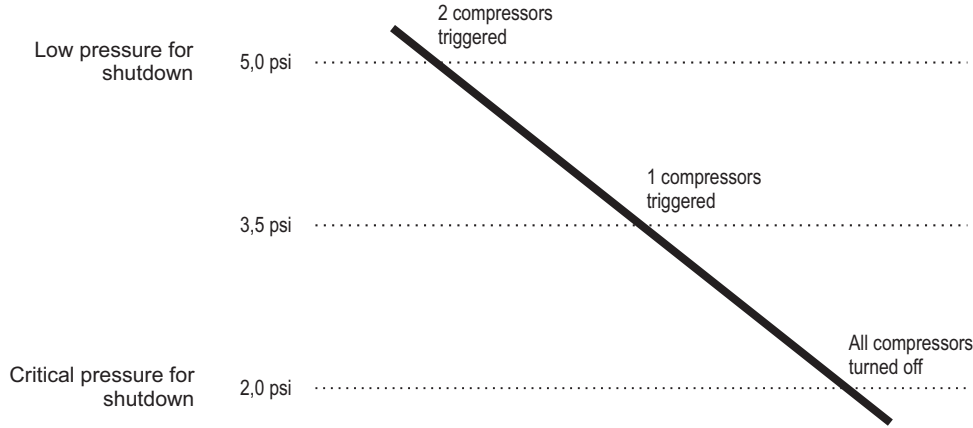

In this example, when the pressure reaches 5.0 psi 2 compressors are activated. One compressor is turned off at 3.5 psi, which is half of the range, and the other compressor is turned off at 2.0 psi.

Example with VCC compressor:

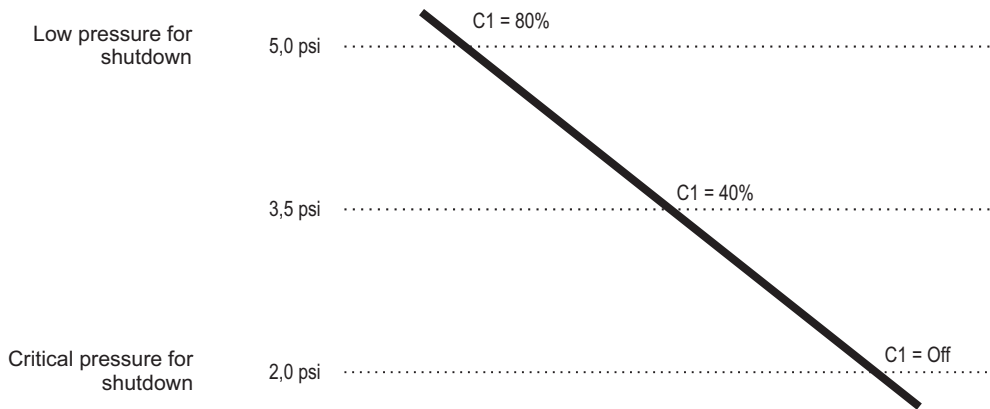

In this example, the moment the pressure reaches 5.0 psi the compressor operates at 80% of its capacity. Capacity is scaled down until compressor shuts off at 2.0 psi.

16.DISCHARGE CONTROLS

16.1 Control Modes

The Discharge Control Mode (1.3.x.1) defines the preference of fans actuation and shutdown. To control the discharge, the **RCK-862_{plus}** has the following control modes: Linear Mode, Rotation Mode, Dead Zone Mode, Dead Zone Mode with Rotation.

16.2 Types of discharge control

The discharge control can be carried out by monitoring the pressure or temperature variable. The type of control is adjusted according to the variable to be used in the parameter Type of control (1.3.x.2).

Pressure: When configuring the Control Type (1.3.x.2) for pressure, the **RCK-862_{plus}** uses the parameters related to pressure of 1.3.x.6 to 1.3.x.10. In this type of control, a temperature sensor (1.3.x.21) can also be added to monitor the condenser refrigerant outlet temperature (sub-cooling calculation).

Temperature: When configuring the Control type (1.3.x.2) for temperature, the **RCK-862_{plus}** uses the parameters related to temperature 1.3.x.11 to 1.3.x.18.

16.2.1 Linear Mode

16.2.1.1 Linear Mode linked only with digital fan outputs ON/OFF

Linear mode, when it only has digital outputs linked, controls the actuation and shutdown of each fan sequentially and with pressure / temperature intervals of the same magnitude (step).

The **RCK-862_{plus}** uses a setpoint value and pressure or temperature hysteresis (depending on the type of control) to control the discharge.

Actuation Pressure value of the "N" Output Actuation = Setpoint + (N x Step)

Shutdown Pressure value of the output "N" Actuation = Setpoint + (N-1 x Step)

$$\text{Step} = \frac{\text{Digital hysteresis}}{\text{Number of outputs}}$$

Pressure value for output "N" actuation

Activation = Setpoint + (N x Step)

Pressure value for output "N" deactivation

Activation = Setpoint + (N-1 x Step)

Example:

1.3.x.1 Control mode: Linear

1.3.x.3 Setpoint: 250 psi

1.3.x.5 Hysteresis of digital outputs: 20

1.3.x.24 Number of fans: 6

1.3.x.25 Fan 1 modulation: without modulation

1.3.x.39 Integral Time: Off

In this case, each fan is associated with a digital output and the step is defined as 60/6 = 10 psi.

Outputs

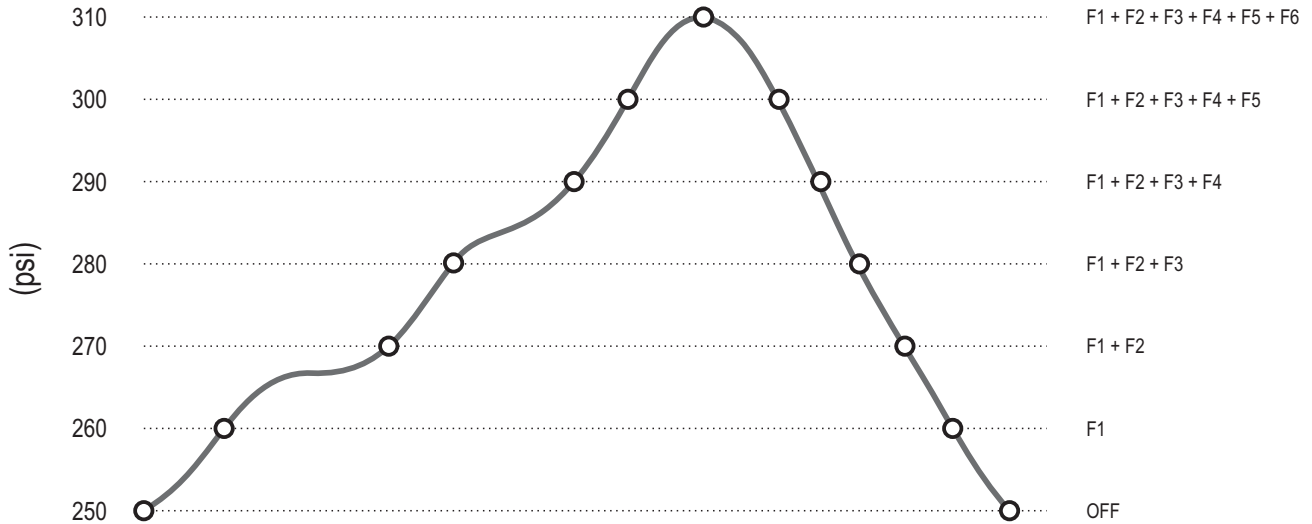

16.2.1.2 Inverter-modulated fan:

The control of fans with frequency inverter uses an analog output (0-10V).

Only fan 01 of each discharge line can be configured as an inverter. During operation, the inverter-modulated fan is the first to be actuated and the last to be shutdown. Example: In item 1.3.x.25 o "Modulation of fan 01" as "Inverter" and select an analog output for the Inverter. You can select a digital output for the start/stop function by selecting a digital output in the parameter Fan Digital output (1.3.x.27).

The working values of the output (maximum, minimum and start) can be configured in the menu Analog outputs 1.10.

Integral actuation can be selected together with proportional (PI mode) using the parameter Integral Time (1.3.x.39).

Note: When more than one fan is controlled by only a single proportional output, the number of fans (1.3.x.24) is set to 1 and Compressor Modulation (1.3.x.25) as Inverter.

16.DISCHARGE CONTROL

16.2.1.3 Linear mode using a fan (inverter) together with fans linked with digital outputs:

Fan 1 of each discharge line can be controlled proportionally and linked with a proportional 0-10V analog output for its control. To do this, select the modulation of fan 1 as an inverter and assign an analog output (1.3.x.26). The use of an output with Start-Stop function is optional and to configure it, just select a digital output for the fan in the parameter Fan 1 Digital output (1.3.x.27).

When the inverter fan works together with ON/OFF fans, the control is done through a setpoint value and two hysteresis. The hysteresis of the analog output (1.3.x.6) corresponds to the maximum value of the inverter compressor output and the hysteresis of the digital outputs (1.3.x.5) corresponds to all ON/OFF actuated.

The inverter fan is the first to be actuated and the last to be shutdown. The ON/OFF fans are actuated after the inverter fan reaches 100% of its speed. For each fan driven, the output of the Inverter compressor is reduced to compensate for the added portion. Similarly, when a fan is turned off, the value of the analog output increases to compensate for the portion that has been reduced.

Example:

1.3.x.1 Control mode: Linear

1.3.x.2 Control type: Pressure

1.3.x.3 Setpoint: 250

1.3.x.5 Hysteresis of digital outputs: 20

1.3.x.6 Analog hysteresis: 10 psi

1.3.x.24 Number of fans: 3

1.3.x.25 Fan 1 modulation: without modulation

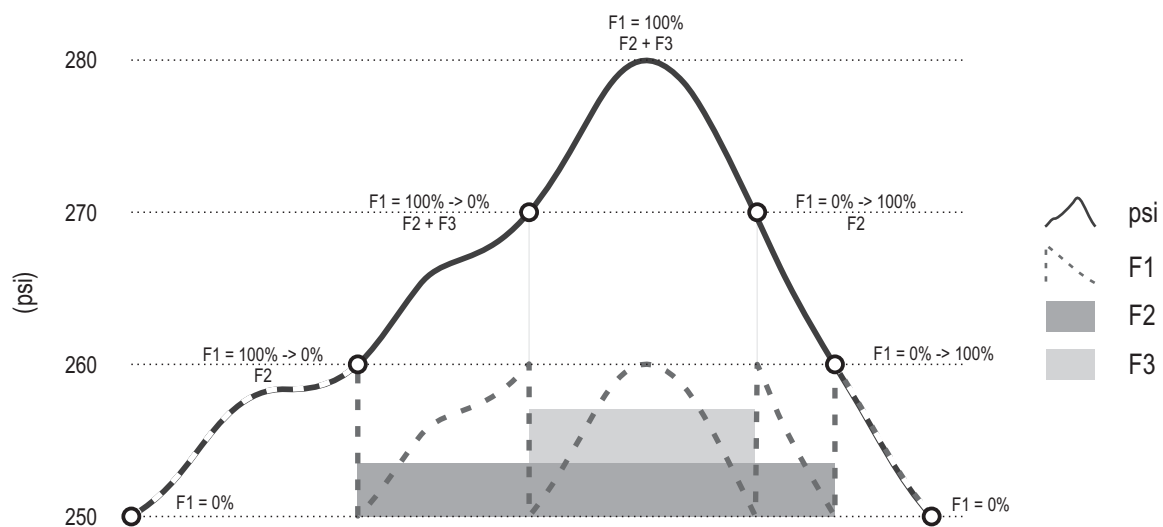

1.3.x.39 Integral time: Off

In this case, each fan is linked with a digital output and the step is defined as $20/2 = 10$ psi.



16.2.2 Rotation:

This mode operates in a similar way to the Linear Mode, however, making an hourly rotation to actuate and shutdown fans according to the record of the entire hours worked by each piece of equipment. When the control recognizes the need to start a fan, the preference will be given for the fan with the lowest number of entire work hours recorded. Likewise, when it is necessary to shut down a fan, the preference will be given to the one with highest number of work hours recorded.

The record of the number of hours worked by each fan is displayed in the control menu, in the Hour meter option. In this same menu it is possible to reset one (select the compressor and press ) or all (hold  for 2 seconds) the time records.

As a fan with Inverter modulation it is always the first to be actuated and the last to be shut down it does not enter the rotation, that is, the rotation is made only with ON/OFF fans.

16.2.3 Dead Zone:



This Control Mode is used to create a control region around the setpoint without actuating and shutting down the fans. The operation for discharge pressure switches is like that for suction pressure switches.



Note: The use of proportional fans (inverter) is not allowed in this control mode.

16.2.4 Dead Zone + rotation:

This mode operates in a similar way to the Linear Mode, however, making an hourly rotation to actuate and shut down the fans according to the hours worked. When the control recognizes the need to start a fan, the preference will be given for the one with the lowest number of entire work hours recorded. Likewise, when it is necessary to shut down a fan, the preference will be given for the one with the highest number of entire work hours recorded.

The number of hours worked by each fan can be viewed in the control menu, in the Hour meter option. In this same menu it is possible to reset one (select the compressor and press ) or all (hold  for 2 seconds) time records.

As a fan with Inverter modulation, it is always the first to be actuated and the last to be shut down, it does not enter the rotation, that is, the rotation is made only with fans without modulation.



Note: The use of proportional fans (inverter) is not allowed in this control mode.

16.DISCHARGE CONTROL

16.2.5 Integral Action:

In some systems the control of fans with only proportional action (Setpoint and hysteresis) tends to present an error in steady state (not reaching the setpoint) or to show oscillatory behavior (excessive pressure variation around the setpoint and high number of fan activations).

In these cases, the use of integral action together with proportional control has the objective of keeping the control pressure stable, converging to values close to the setpoint.

Proportional-only control

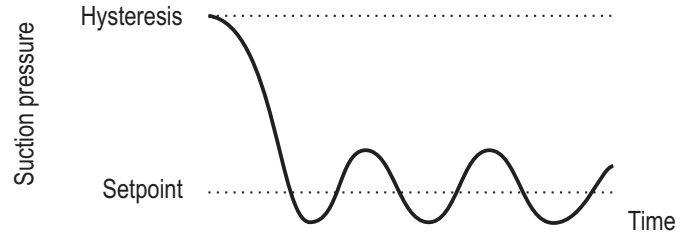
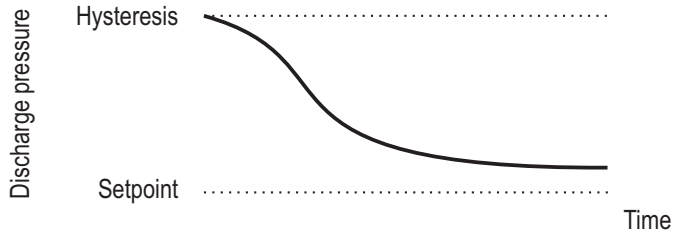

Proportional + Integral Control

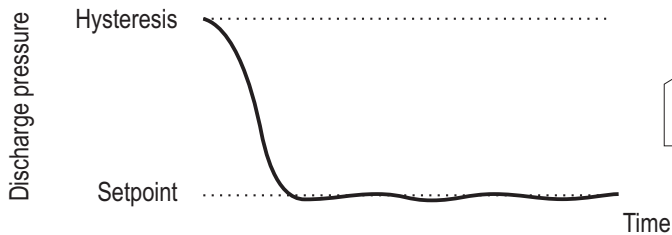

Note: Integral effect reduced the oscillation and brought the system closer to the setpoint.

The integral action can be used in all control modes, including those that operate only on the ON | OFF outputs. To activate the integral action, simply set a value other than Off outputs. To activate the integral action, simply set a value other than Off in the parameter Integral time (1 . 3 . x . 39).

The higher the configured value, the slower and more stable the system's behavior.

The lower the configured value, the faster and more oscillatory the behavior is.



Note: The definition of this parameter depends on the capacity of the system and the response speed of its pressure fluctuations. It is suggested to start the tests to define these parameters using the value of 350 seconds.

17.AUXILIARY FUNCTIONS

The **RCK-862 plus** allows configuring some complementary functions to control the Rack system. The Pump Down and Compressor protection thermostat logic apply to suctions. The logic of adiabatic condensation and floating condensation apply to discharges and aims to adjust the Rack to work with less energy consumption. The individual pressure switch logics allow to control up to 3 pressure switches independently from the main control of the Rack.

The individual thermostat logic allows controlling the temperature individually or linked with a suction pressure switch, as well as perform defrost logics based on time.

The logic of rotating outputs allows you to cycle the actuation of outputs based on time. And the Control Status Logic allows to link a digital output to indicate the activate of the control

17.1 Pump down:

Pump Down allows for the shutdown of the Cooling groups with collection of the refrigerant fluid. By activating Pump Down the control switches off the last compressor of each suction at a pressure setpoint lower than the operating pressure setpoint, thus allowing to reduce the amount of cooling fluid stored in the suction lines.

To configure the Pump Down, access menu 1 . 7 . 1 . **RCK-862 plus** allows the Pump Down shutdown to be done manually, for a group of suctions, or automatically, for each suction line.

For manual shutdown, it is recommended to assign a digital output to command a block valve for the group.

For automatic shutdown there are two options: Controlled by the **RCK-862 plus** via a digital output, for commanding a block valve or for signaling an expansion valve controller; or controlled by thermostats, with no digital output assigned, to use with multiple evaporators with multiple evaporators.

During the Pump Down process the low pressure and critical superheat, low and high alarms remain off.

Manual shutdown:

The manual shutdown feature can be used in case of a need to shut down for maintenance or outage for long periods. It must be done via Control Menu - Pump Down or via RS-485. When the command to perform the withdrawal is sent, the group's Pump Down output is activated so that the fluid passage is blocked. The last compressor of each suction line remains in operation until the suction pressure reaches the value set in "Group x: Shutdown pressure" (1 . 7 . 1 . 1 . 1 , 6 or 11) or until the time set in "Group x: Maximum Shutdown Time" (1 . 7 . 1 . 1 . 2 , 7 or 12). The output remains activated until a new command is sent to exit the Pump Down condition.

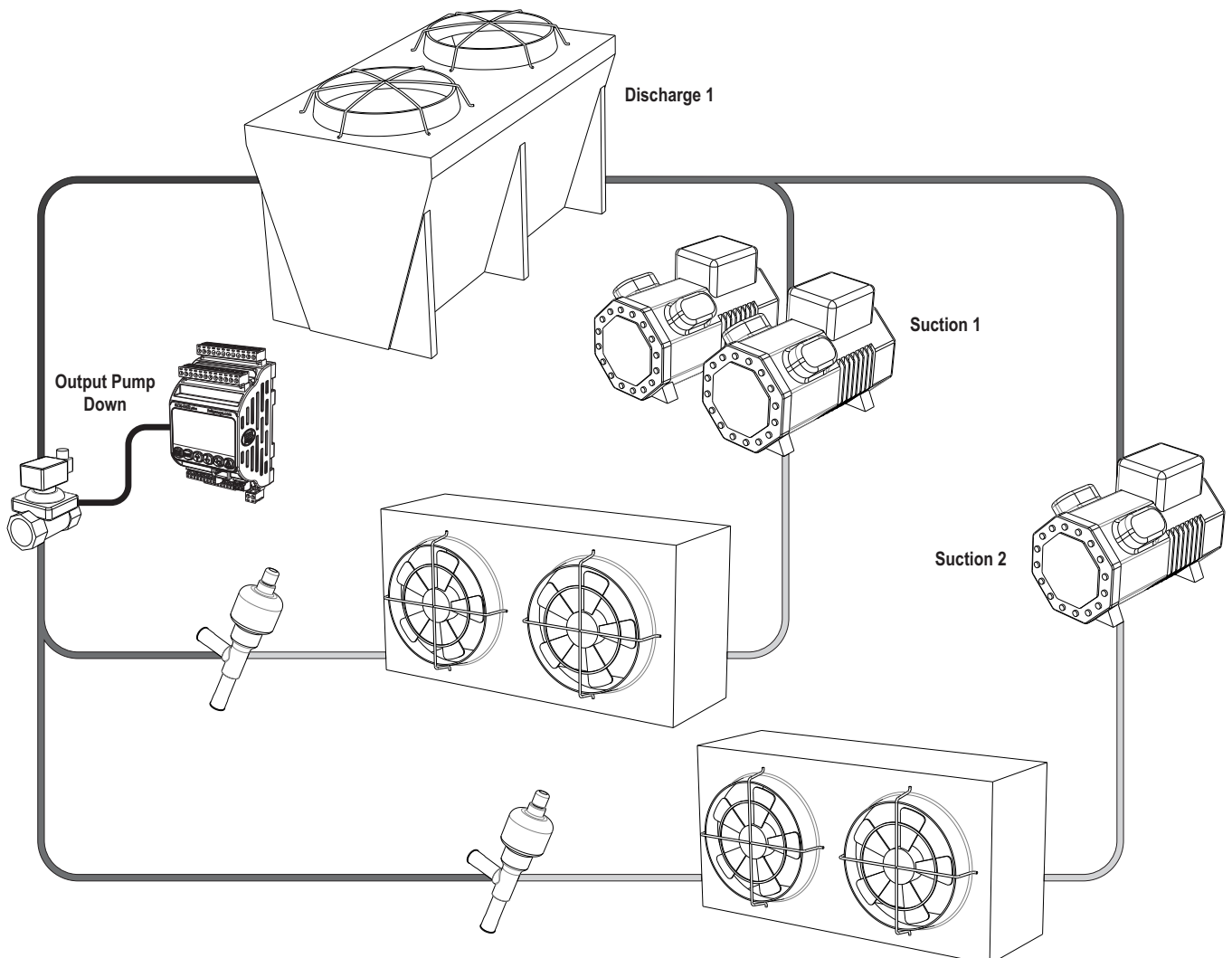

17.AUXILIARY FUNCTIONS

Example:

Group 1 with two suctions and a digital output for activating a Pump Down valve:

Groups:

1.1.2 Number of suction pressure switches: 1

1.1.5 Suction 1 Group : Group 1

Suction 1:

1.2.1.3 Pressure setpoint: 50.0 psi

1.2.1.6 Hysteresis of On/Off compressors: 10 psi

1.2.1.31 Number of compressors: 2

1.2.1.38 Modulation of compressor 1: On/Off

1.2.1.39 Modulation of compressor 2: On/Off

1.2.1.53 Main output of compressor 1: O1

1.2.1.57 Main output of compressor 2: O2

17.1 Pump Down:

1.7.1.1 Group 1: Shutdown pressure: 5.0 psi

1.7.1.2 Group 1: Maximum shutdown time: 30 seconds

1.7.1.3 Group 1: Enables Pump Down: Yes (flow blocking is done by the digital output)

1.7.1.4 Digital output: O4

1.7.1.5 Contact type NO - NC: NC (Output on releases fluid flow)

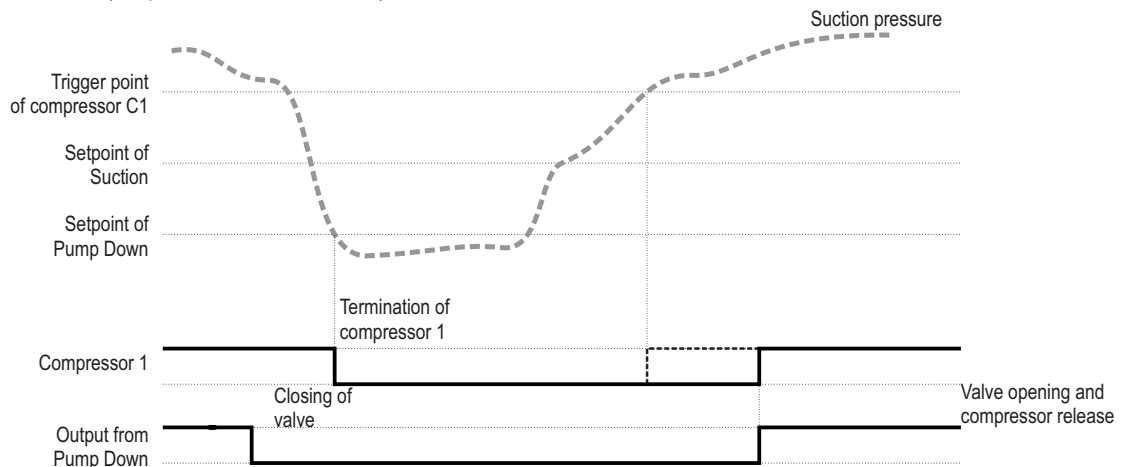

17.2 Automatic shutdown commanded by RCK-862 plus:

If a digital output with fluid collection function is assigned to a suction line (1.7.1.17, 20 or 23) the compressors are switched off with fluid collection, except in the case of a shutdown due to an alarm.

The **RCK-862 plus** assumes that the pumpout output commands a valve to stop the cooling flow or sends a signal to an external controller for the electronic expansion valve to close. The output is activated when it is necessary to turn off all the compressors, either because the suction line has reached the setpoint or due to a defrost event.

During shutdown, the last active compressor of the suction line is turned off only when the pressure reaches the pressure value for group shutdown (1.7.1.1, 6 or 11) or when the maximum time has elapsed (1.7.1.2, 7 or 12).

17.AUXILIARY FUNCTIONS

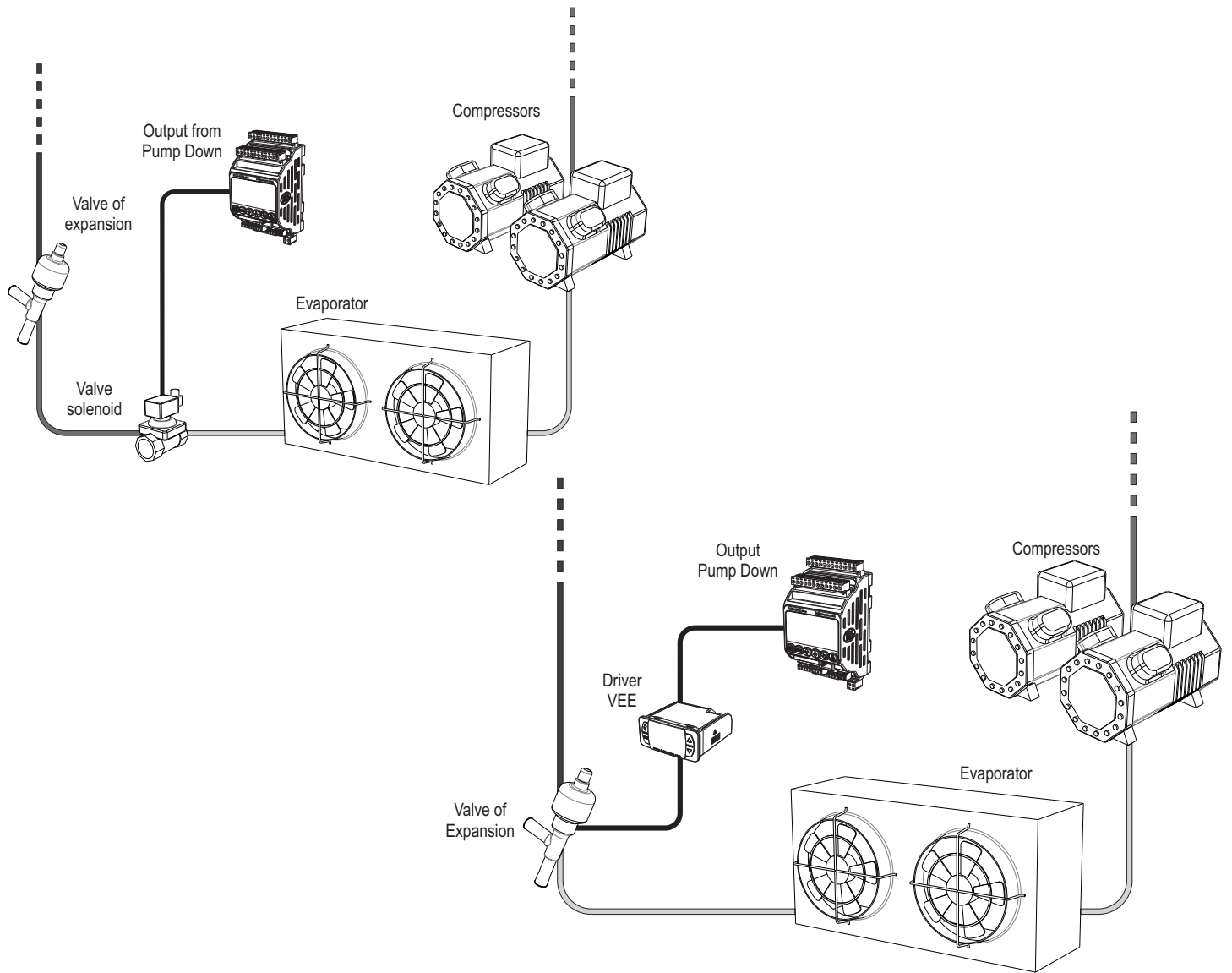

Example:

Suction 1 operating with 2 compressors and a digital output for activating a Pump Down valve:

Groups:

1. 1. 2 Number of suction pressure switches: 1

1. 1. 5 Suction 1 Group: Group 1

Suction 1:

1. 2. 1. 3 Pressure setpoint: 50.0 psi

1. 2. 1. 6 Hysteresis of On/Off compressors: 10 psi

1. 2. 1. 31 Number of compressors: 2

1. 2. 1. 38 Modulation of compressor 1: On/Off

1. 2. 1. 39 Modulation of compressor 2: On/Off

1. 2. 1. 53 Main output of compressor 1: O1

1. 2. 1. 57 Main output of compressor 2: O2

Pump Down:

1. 7. 1. 1 Group 1: Shutdown pressure: 5,0 psi

1. 7. 1. 2 Group 1: Maximum shutdown time: 30 seconds

1. 7. 1. 16 Suction 1: Enables Pump Down: Yes (flow blocking is done by the digital output)

1. 7. 1. 17 Suction 1: Digital output: O5

1. 7. 1. 18 Suction 1: Contact type NO - NC: NC (Output on releases fluid flow)

17.AUXILIARY FUNCTIONS

17.3 Automatic shutdown commanded by thermostats:

Automatic shutdown can be done through a link with one or more thermostats. The thermostats are responsible for commanding the start of shutdown and the return of the Pump Down state, releasing the activation of the compressors. A link between an external thermostat (cold room controller) and a suction line is accomplished by configuring an auxiliary input with the Pump Down function in menu 1.6. In this case, the connection between an external controller output and an **RCK-862 plus** input is required. To create a link between an internal thermostat "Individual Thermostat (1.7.6)" and a suction line simply select the suction line in the 1.7.6.x.7 menu.

If none of the linked thermostats have a demand for Cooling, the flow of refrigerant fluid is blocked by the thermostat valves and the **RCK-862 plus** understands that it must perform a shutdown with fluid withdrawal. In this case, the last compressor in the suction line remains active until the value of the shutdown pressure (1.7.1.x.1,6 or 11) or the Maximum Time (1.7.1.x.2,7 or 12) is reached.

If at least one thermostat has a demand for Cooling, the shutdown process is completed and the compressors remain ready to go into operation.

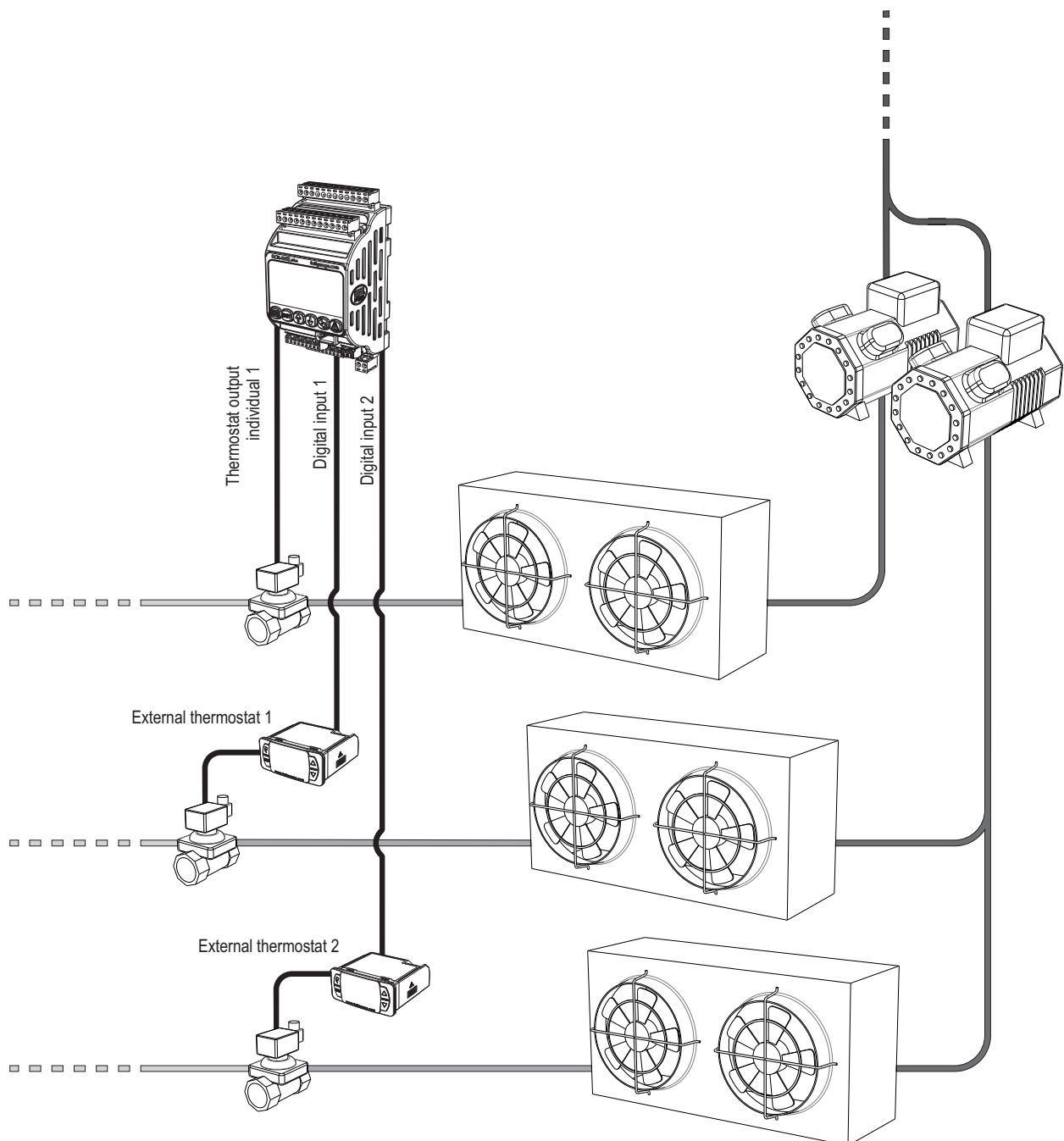

17.AUXILIARY FUNCTIONS

Example:

Suction 1 operating with 2 compressors, 2 External Thermostats and 1 Individual Thermostat:

Suction 1:

1.2.1.3 Pressure setpoint: 50.0 psi

1.2.1.6 Hysteresis of On/Off compressors: 10 psi

1.2.1.31 Number of compressors: 2

1.2.1.38 Modulation of compressor 1: On/Off

1.2.1.39 Modulation of compressor 2: On/Off

1.2.1.53 Main output of compressor 1: O1

1.2.1.57 Main output of compressor 2: O2

Pump Down:

1.7.1.1 Shutdown pressure: 5.0 psi

1.7.1.2 Maximum shutdown time: 30 seconds

1.7.1.3 Group 1: Enables Pump Down: No (the flow blocking is done by the thermostats)

1.7.1.16 Suction 1: Enables Pump Down: Yes (flow blocking is done by the digital output)

External thermostats (auxiliary inputs 1 and 2):

Input 1:

1.6.1.1 Link of use: Suction 1

1.6.1.2 Input function: Activates Pump Down

1.6.1.3 Digital input address: I1

1.6.1.4 Contact type NO - NC: NO

Input 2:

1.6.2.1 Link of use: Suction

1.6.2.2 Input function: Activates Pump Down

1.6.2.3 Digital input address: I2

1.6.2.4 Contact type NO - NC: NO

Internal Thermostat (Individual Thermostat 1):

1.7.6.1.1 Operation mode: Cooling

1.7.6.1.2 Temperature setpoint: 5°C

1.7.6.1.7 Linked pressure switch: Suction 1

1.7.6.1.9 Main output: O4

In this example, the Suction 1 control goes into Pump Down process if the digital inputs I1 and I2 are activated and the Output O4 is off. (External thermostats requesting Pump Down and Internal thermostat below setpoint).

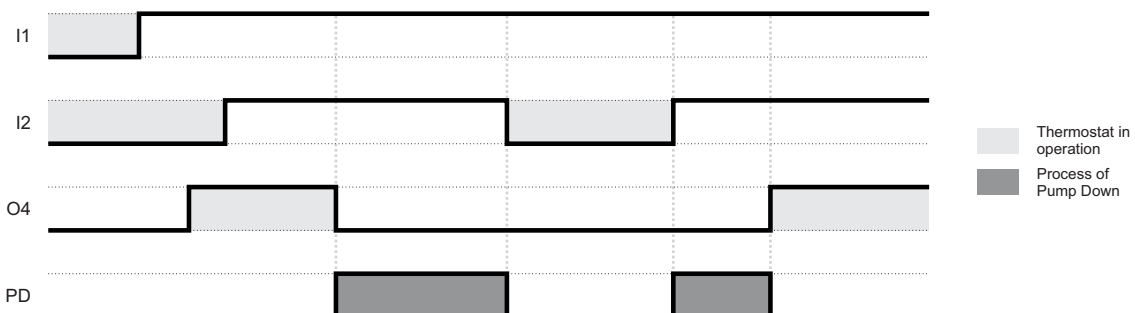

After the last compressor is turned off, the activation of the compressors remains blocked until one of the thermostats has a demand for refrigeration. (Inputs I1 or I2 off or output O4 on).

17.AUXILIARY FUNCTIONS

17.4 Pump control:

RCK-862 plus allows configuring up to 3 pairs of outputs, 1 for each line and suction, with pump rotation function. In each set, it is possible to configure two digital outputs that operate alternately, respecting the output rotation time (1.7.7.x.1) and the transition time (1.7.7.x.2) which is the time that both outputs remain on before switching.

To configure a lack of flow digital input, the respective set of outputs must be selected in the menu (1.6.x.1) and the input function (1.6.x.2) as Safety 1 for pump flow sensor 1, Safety 2 for pump 2 flow sensor or Safety 3 for common flow sensor for both pumps.

Outlet sets 1, 2 and 3 operate in conjunction with suctions 1, 2 and 3 respectively. The compressors start operating only after starting one of the pumps and are turned off in case of lack of flow alarm in both pumps.

When energizing the controller, the first pump to be activated is the one with the fewest operating hours. This prevents rotation failures during power outages.

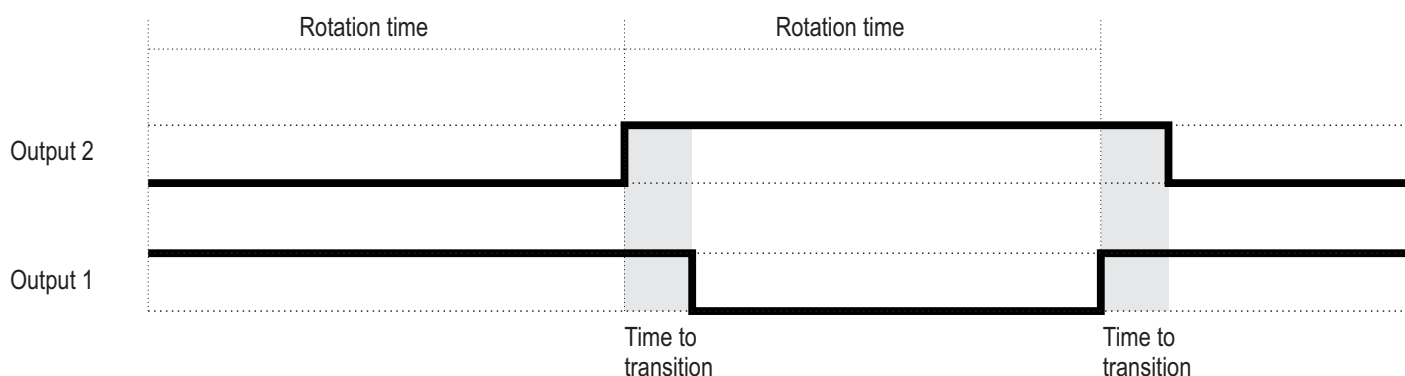

Pump control for a cooled water circuit by suction 1 and flow sensor installed in cooled water line.

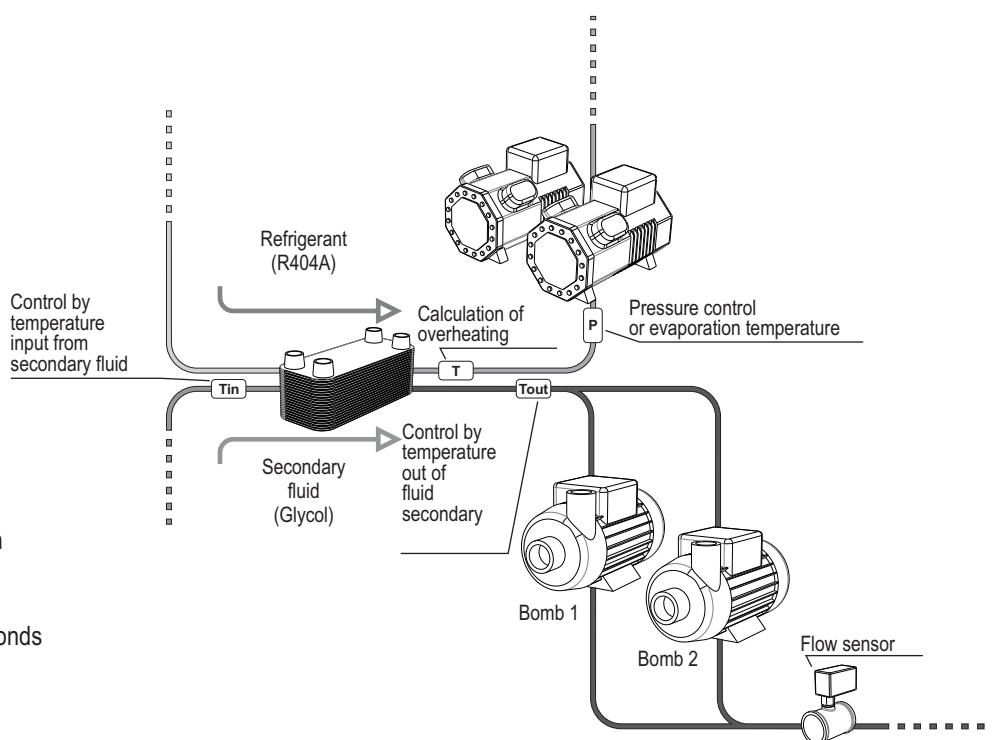

Pump control:

- 1.7.7.1.1 Time to rotate outputs = 720 min
- 1.7.7.1.2 Transition time = 5 seconds
- 1.7.7.1.3 Compressor start time = 20 seconds
- 1.7.7.1.4 Digital output address 1 = 05
- 1.7.7.1.5 Digital output address 2 = 06

Auxiliary inputs:

- 1.6.1.1 Input 1: Link of use = Control of pumps 1
- 1.6.1.2 Input 1: Input Function = Security 3
- 1.6.1.3 Input 1: Digital input = I5
- 1.6.1.4 Input 1: Contact type NO - NC = NO (Input triggered indicates lack of flow)

Alarms:

- 1.4.1.1 Time to validate alarms = 5 seconds

17.AUXILIARY FUNCTIONS

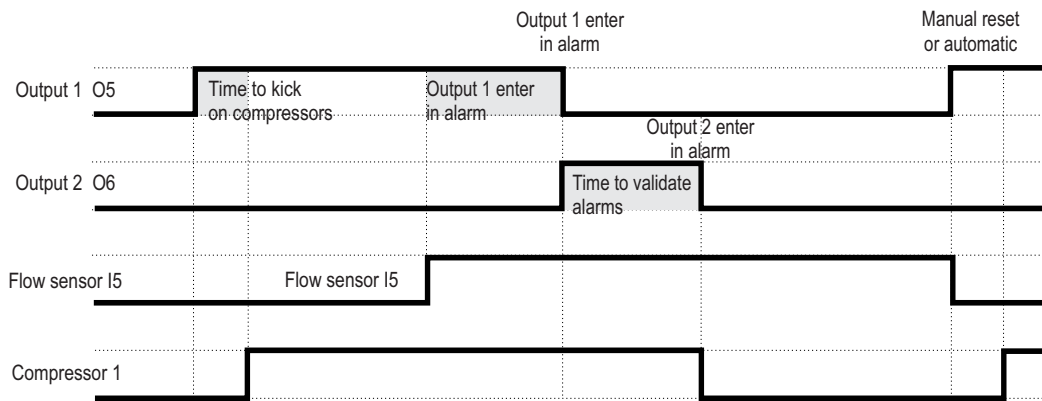

In this example, the first suction compressor 1 is only activated 20 seconds after the start of the first pump and the pumps are rotated every 720 minutes. The function of the digital input is to signal that the flow of chilled water has been stopped. If this input is activated, the output that is operating goes into alarm and the other output is activated. If the flow remains interrupted, the second pump goes into alarm and the suction 1 compressors are turned off in order to prevent freezing of the water line. Outputs alarms respect the rearming logic defined in the menu 1.4.4.

17.5 Defrost for suction lines:

By stopping the compressor controlled through suction lines directly **RCK-862 plus**, either manually, via menu or RS-485, by time or defrost schedule.

Compressors are switched off, respecting the compressor on and off times, or with fluid collection, if enabled in menu 1.7.1. The defrost time is counted after switching off the last compressor.

17.6 Defrost by time:

When 1.7.9.x.1 is configured as "Time" the functions "Interval between defrosts" (1.7.9.x.2) and "Defrost time" (1.7.9.x.9) are considered. In this way, the suction line goes into defrost after the interval has elapsed. The interval between defrosts is considered after the end of the last defrost.

17.7 Defrost by schedule:

You can configure the defrosting schedule to be equally distributed across the day by programming the number of defrost cycles per day. For this, it is necessary to configure the defrost start as "Schedule" (1.7.9.x.1), and through functions 1.7.9.x.3 to 1.7.9.x.8 configure the amount of defrosts per day and its starting time. With this, the defrost schedule makes it possible to create a schedule from Monday to Friday, another schedule for Saturday and another for Sunday. For Example: If for the schedule from Monday to Friday, the preferred time is set to 1:00 pm and the number of defrosts is set to 4 (6-hour interval), the defrost will be carried out at 01:00 AM, at 07:00 AM, at 01:00 PM and 07:00 PM on the same day.

MONDAY TO FRIDAY

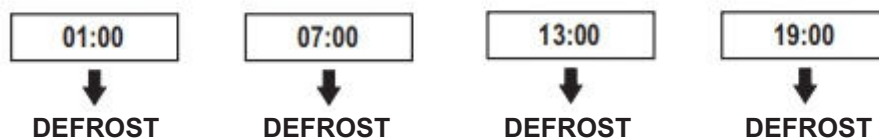

17.AUXILIARY FUNCTIONS

17.8 Compressor protection thermostats:

A protection thermostat can be configured for each of the 6 compressors on the 3 suction lines. Each thermostat has a sensor for measuring the compressor temperature, a digital output for activating a cooling device and a shutdown alarm. The output is activated, and the high temperature alarm only occurs when the compressor is on.

The output is activated if the sensor temperature is higher than the control temperature value (1.7.2.x.1) + hysteresis (1.7.2.x.3) and the output is switched off if the temperature value is lower than the value is lower than the value of the control temperature.

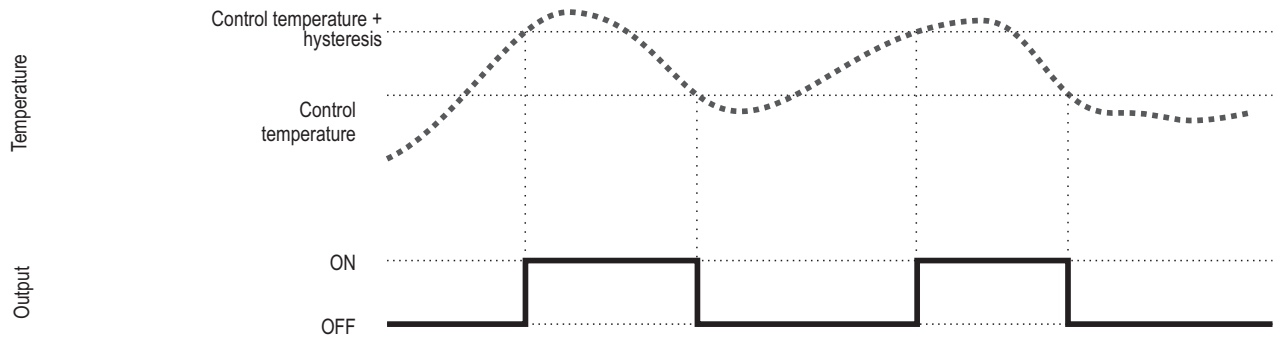

In the Compressor protection thermostats function, a maximum temperature for compressor operation can be defined. If the compressor temperature exceeds the value of Compressor shutdown temperature (1.7.2.x.2), the compressor will shut down and an alarm event will be created. The compressor returns to operation when the thermostat temperature sensor is below the shutdown temperature minus hysteresis.

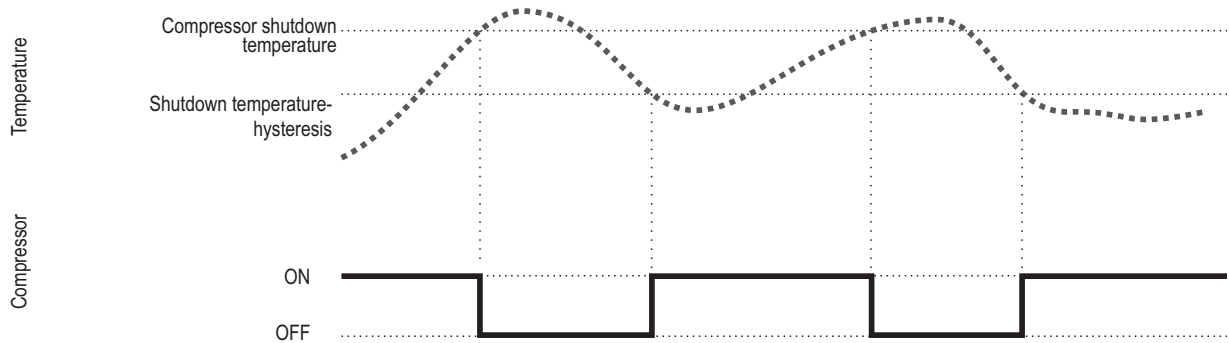

17.9 Adiabatic condensation:

Using the adiabatic condensation logic, it is possible to reduce the temperature of the external air in contact with the condenser and, consequently, reduce the operating pressure of the discharge. The control of adiabatic condensation activates a water pump or a valve that feeds the water curtain through which the external air passes before reaching the condenser. The activation of the output is done by temperature control, using one or two sensors, or exclusively by time acting by means of a cycle timer (time on and time off). The control is permanently active if its Control Mode (1.7.3.x.1) is not determined using the Start time (1.7.3.1.13) and End time (1.7.3.1.14) or associated with a digital input.

17.9.1 Temperature control:

In the Temperature control mode, a sensor must be installed to measure the temperature of the external air (dry bulb sensor) and optionally another sensor to measure the air temperature after passing through the water curtain (wet bulb sensor). The Control Mode (1.7.3.x.1) can be configured as Temperature with a cycle timer and in this case the output cycles between on and off instead of remaining on, whenever the temperature activation condition presents the activation condition. The cycle period must be configured in the parameters Time on (1.7.3.x.9) and Time off (1.7.3.x.10).

If the parameters Temperature for actuation and / or Temperature for shutdown are set to OFF, the control is performed only by differential, using the two sensors.

If the parameters Differential for actuation and / or Differential for shutdown are set to OFF, the control is performed only by temperature, using only the dry bulb sensor.

If the Control Mode (1.7.3.x.1) is configured as Temperature with a cycle timer, the output will be cycling instead of being permanently activated, whenever the temperature activation condition presents the activation condition.

The cycle period must be configured in the parameters Time on (1.7.3.x.9) and Time off (1.7.3.x.10).

17.AUXILIARY FUNCTIONS

17.9.1.1 Temperature control using two sensors (Differential TBS-TBU)

The control output is activated whenever the differential between the readings of the two sensors is lower than the Activation differential (1.7.3.x.4) and will be shut off when the differential is greater than the Shutdown differential (1.7.3.x.5). In this case it is necessary to use two sensors, one for dry bulb temperature (1.3.x.23) and the other for wet bulb temperature (1.7.3.x.9). Temperature differential control will only be enabled when the external temperature (TBS) is higher than the value set in the parameter Minimum operating temperature (1.7.3.x.6). If the shutdown differential is not reached within the time interval configured in Differential validation time (1.7.3.x.7) the output will be switched off and will remain blocked until the time for the next attempt has elapsed (1.7.3.x.8). For the control to be carried out using the two sensors, the parameters Temperature for activation (1.7.3.x.2) and Temperature for shutdown (1.7.3.x.3) must be set to OFF.

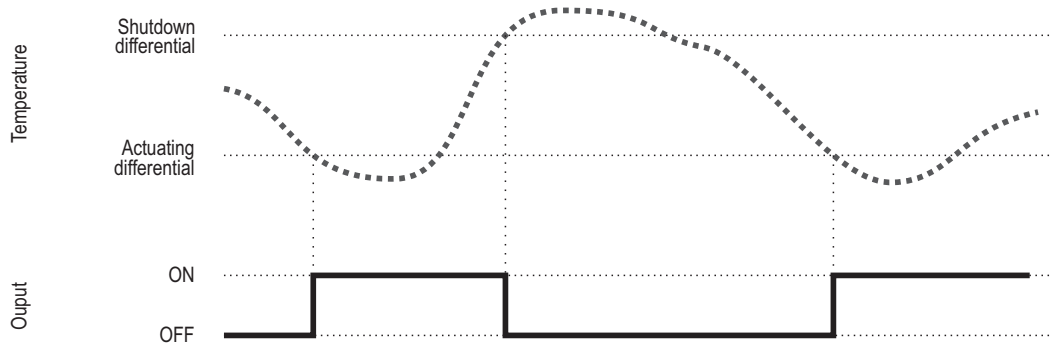

17.9.1.2 Temperature control using a sensor (TBS)

In this mode, only a temperature sensor is used to measure the air temperature in the environment where the condenser is located. If the Temperature value for activation (1.7.3.x.1) is reached, the control output is activated until it returns to the Temperature for shutdown (1.7.3.x.2).

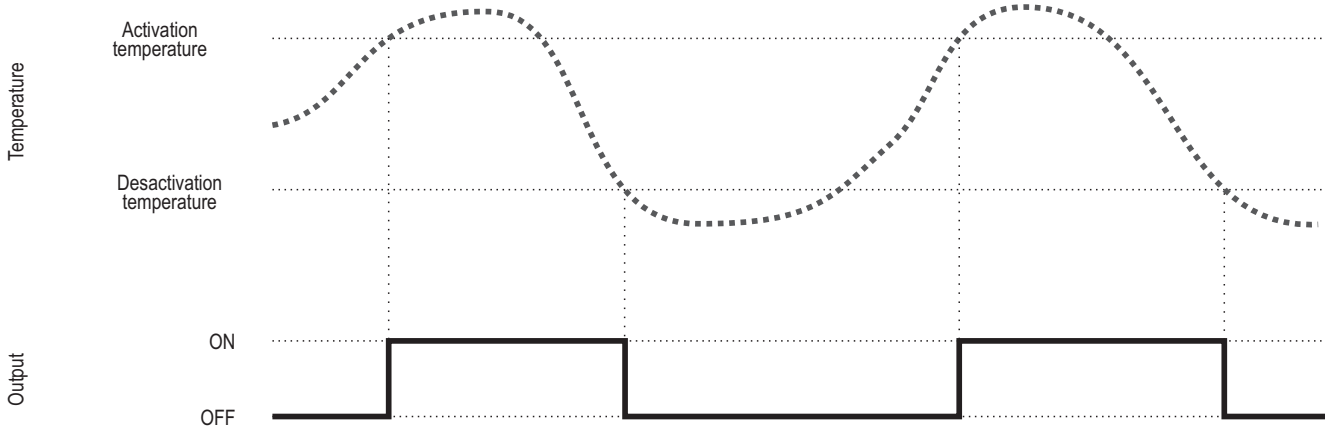

17.9.1.3 Temperature control using two sensors (TBS-TBU Differential and Temperature Limit)

When the four parameters: Temperature for activation (1.7.3.x.2), Temperature for shutdown (1.7.3.x.3), Differential for activation (1.7.3.x.4) and Differential for shutdown (1.7.3.x.5), the control is done by both modes (temperature differential and temperature limits). Whenever at least one of the two modes have an actuation condition, the **RCK-862^{plus}** activates the control output of the adiabatic condensation. In this case, the output will be activated when the temperature of the dry bulb sensor exceeds the Temperature for activation and will be shut down when the temperature is lower than the Temperature for shutdown; or the output will be actuated when the differential is less than the Differential for activation and will be shut down when the differential is greater than the Differential for shut down.

17.9.1.4 Cycle timer mode:

The control of adiabatic condensation is performed exclusively by cycling the Time On (1.7.3.x.9) and the Time Off (1.7.3.x.9). The digital output (1.7.3.x.8) linked with the water control switches its operation from on to off according to the time parameters. In this case, it is suggested to limit the period of operation of the adiabatic condensation by the parameters Start Time (1.7.3.1.11) and End Time (1.7.3.1.12).

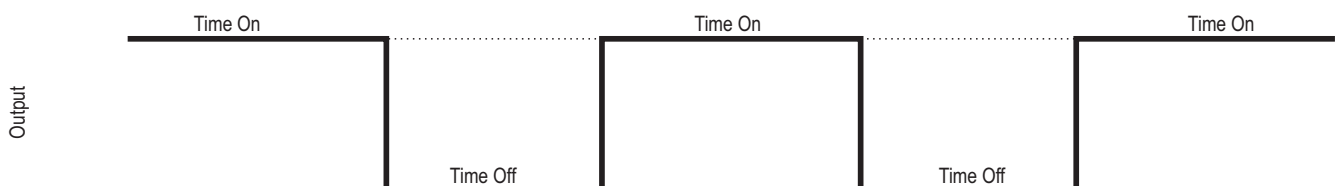

17.AUXILIARY FUNCTIONS

17.11 Floating condensation:

The floating condensation logic can be used to lower the compressor discharge pressure and consequently reduce the compressor's energy consumption according to the air temperature value. To use the logic, a pressure sensor must be configured for the discharge, a temperature sensor for measuring the external temperature and a temperature sensor for calculating the subcooling.

In the Floating condensation menu (1.7.4) you can access the essential parameters for the logic to work, such as the Temperature to start the fluctuation (1.7.4.x.1), the minimum safety setpoint (1.7.4.x.2) and safety subcooling value (1.7.4.x.3).

This logic can be programmed to work only in a complying time interval (1.7.4.x.4 and 1.7.4.x.5) or by means of the command of an auxiliary input (1.6.x.2).

When enabled, the logic goes into operation as soon as the temperature of the sensor that is measuring the external temperature is lower than the value of the parameter Fluctuation start temperature (1.7.4.x.1). In this case, the discharge setpoint decreases proportionally as the external temperature decreases, following the ratio of 1 to 1 degree until the maximum pressure variation. The controller uses the saturation data of the refrigerant configured for the group belonging to the discharge pressure switch to perform the conversion of pressure to temperature.

Throughout the fluctuation if the calculated subcooling is equal to or better than the safety subcooling parameter (1.7.4.x.3), the control limits the reduction of the discharge setpoint to the moment value. If the subcooling value rises by 33°F, then the floating condensation control returns to reducing the discharge setpoint.

If at any time the subcooling decreases to the low subcooling alarm value, the logic is disabled and the discharge setpoint returns to the original value.

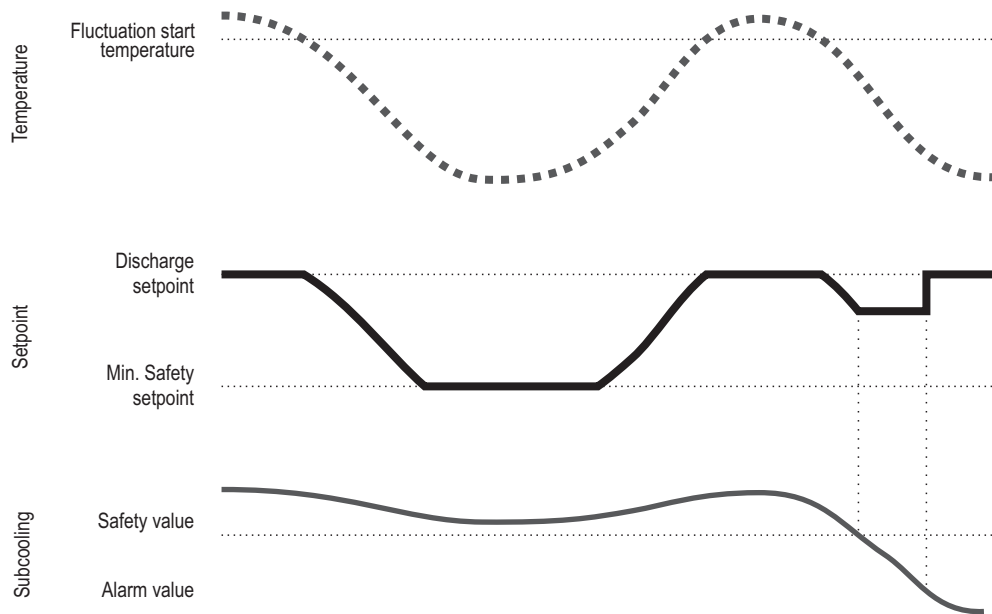

17.12 Individual pressure switches:

The **RCK-862 plus** allows configuring up to 3 individual pressure switches disconnected from the Rack's main control. On each pressure switch, it is possible to associate a pressure sensor and up to 6 digital outputs with setpoint and independent hysteresis.

Each pressure switch can be configured to work in compression or decompression mode. In compression mode, the output is activated if the pressure value is lower than the (setpoint-hysteresis) and shuts off if the pressure value is higher than the setpoint. In the decompression mode, the output is activated if the pressure value is greater than (setpoint+hysteresis) and shuts off if the pressure value is lower than the setpoint.

Example:

- 1.7.5.x Individual pressure switch 1: with two outlets
- 1.7.5.x.1 Operating mode: Decompression
- 1.7.5.x.2 Pressure setpoint 1: 10,0 PSI
- 1.7.5.x.3 Pressure setpoint 2: 20,0 PSI
- 1.7.5.x.8 Pressure hysteresis 1: 5,0 PSI

- 1.7.5.x.9 Pressure hysteresis: 5,0 PSI
- 1.7.5.x.14 Pressure sensor: S1
- 1.7.5.x.15 Digital output address 1: O1
- 1.7.5.x.16 Digital output address 2: O2

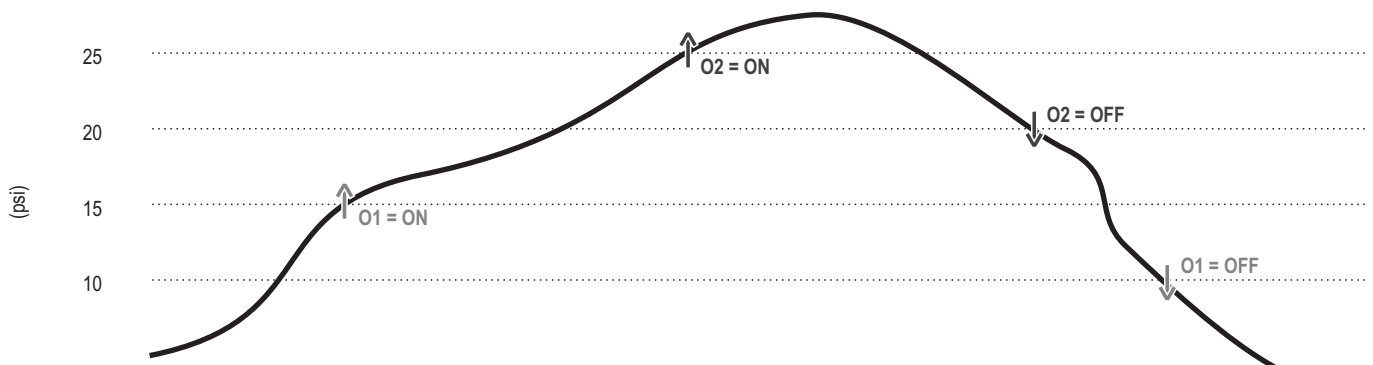

17.AUXILIARY FUNCTIONS

17.13 Individual thermostats:

The **RCK-862_{plus}** allows you to configure up to 6 individual thermostats unrelated to the Rack's main control. Each thermostat can be configured to work in heating or cooling mode. In heating mode, the output is activated if the temperature value is lower than the (setpoint-hysteresis) and shuts off if the temperature value is higher than the setpoint. In cooling mode, the output is activated if the temperature value is higher than (setpoint + hysteresis) and turns off if the temperature value is lower than the setpoint.

Each thermostat has a defrost function, where you can determine a fixed interval between defrosts or select up to 6 independent times to start defrosting. During defrost, the main output of the thermostat is shut off and the defrost output is activated until the time of Defrost duration (1 . 7 . 6 . x . 15) has elapsed. The use of the defrost outlet is optional.

It is possible to synchronize the operation of one or more thermostats with a suction pressure switch. This feature causes the suction pressure switch to go into pump down mode whenever the thermostat turns off (1 . 7 . 6 . x . 7). The pressure switch will only enter Pump Down when all thermostats connected to that suction are shut off.

17.14 Outputs with rotation:

The **RCK-862_{plus}** allows you to configure up to 3 sets of outputs with a rotation function, for controlling pumps, for example.

In each set, it is possible to configure two digital outputs that operate alternately respecting the Time for rotation of the outputs (1 . 7 . 7 . x . 1) and the transition time (1 . 7 . 7 . x . 2), which is the time that the two outputs remain on before making the change.

To configure a lack of flow digital input, the corresponding set of outputs must be selected in the menu (1 . 6 . x . 1) and the input function (1 . 6 . x . 2) as Safety 1 for pump 1 flow sensor, Safety 2 for pump 2 flow sensor or Safety 3 for common flow sensor for both pumps.

Outlet sets 1, 2 and 3 operate with suctions 1, 2 and 3, respectively. The compressors come into operation only after the start of one of the pumps and are switched off in the event of a lack of flow alarm in both pumps.

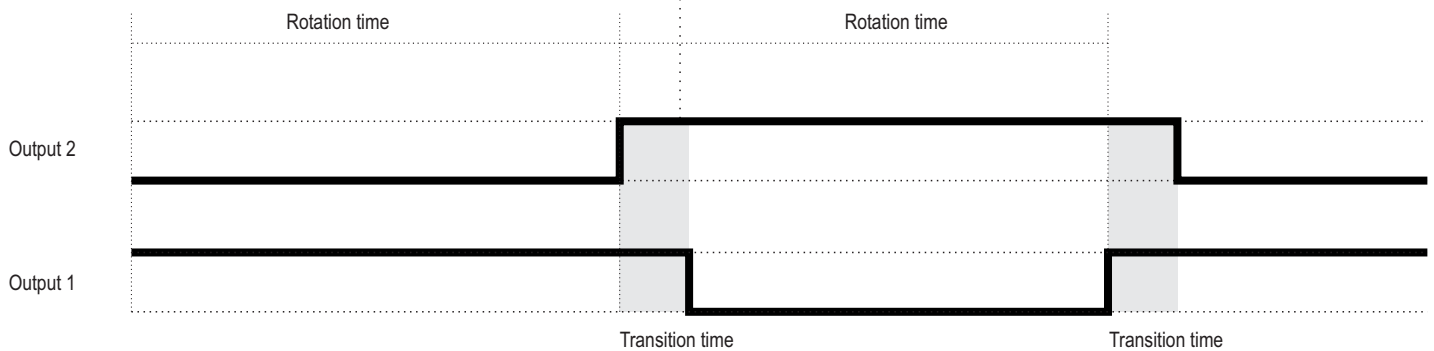

17.15 Control Status:

It allows configuring a digital output for indicating the operation of the controller. This output is only switched off in the event of a power failure and when the control functions are switched off (Control Menu → Control Status = Off).



18.ALARMS

The **RCK-862_{plus}** controller has an alarm system in which it is possible to configure protection or display-only alarms. All alarm settings are linked to the suction and discharge pressure switches. In the event of an alarm, an audible warning will sound and remain active until one of the following conditions occurs:

- The alarm condition no longer occurs, and the alarm is not in a manual reset condition.
- A manual reset was performed (Control Menu).
- The audible warning has been inhibited (by pressing the alarm key for 5 seconds).

If the audible warning function is not desired, it can be disabled in menu 2.4.

18.1 Viewing alarms

One touch on the key  displays active Alarms, a second touch displays alarms on reset and a third touch displays the Alarm History screen. Up to 99 records are stored in each of these three lists, and you can navigate between the records using the keys  and .

When the list is complete, new alarms overwrite older alarm records.

Each alarm record has information about the reason for the alarm, which pressure switch the occurrence was on, start time and time the event stopped.

To delete the alarm records, it is necessary to be viewing the **alarm history** list, press and hold the  key for 3 seconds and confirm the request.

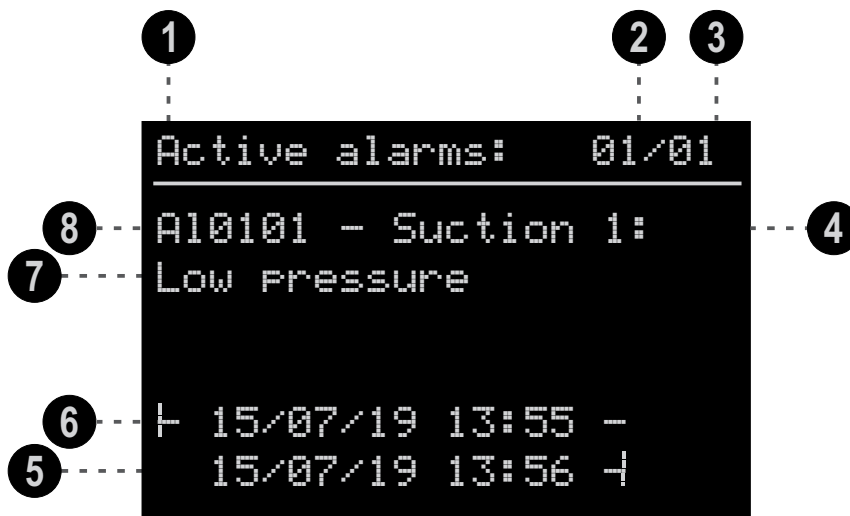

- 1** — Alarm list displayed:
Active alarms: Alarms that are active, in alarm condition
Resets: Alarms that are no longer active but are preventing the operation of a pressure switch. These alarms are in automatic or manual reset condition
Alarm history: Records all alarms that are no longer active or in reset condition
- 2** — Record number of the list being displayed. Record 1 is always the most recent
- 3** — Number of records in each alarm list
- 4** — Pressure switch where the alarm occurred
- 5** — Time the alarm stopped occurring
If the alarm exit time is marked (*), it means that the controller was de-energized while the alarms were active, and it is not possible to determine the exact time when the alarm stopped occurring. In this case, the time when the controller was energized after this occurrence is displayed
- 6** — Alarm start time
- 7** — Reason for alarm
- 8** — Alarm identifier code. See alarm table

18.ALARMS

18.2 Automatic resets:

It is possible to configure automatic resets for protection alarms. In the reset menu (1 . 4 . 4) it is possible to configure the Number of reset attempts (1 . 4 . 4 . 1), the intervals between attempts and a period within which attempts will be made.

If the number of attempts is set to the minimum "Off" value, the reset must be manual only. If the maximum value "Always" is set, the **RCK-862 plus** does not limit the number of reset attempts, it only respects the times.

If the value is set between 1 and 10, this number of attempts will be made within the configured reset period (1 . 4 . 4 . 3) and after this number of attempts, a manual reset should be made.

With each occurrence of protection alarms, it will be checked how many alarms of the same type occurred within the configured period. If it is higher than the configured value, the pressure switch will be blocked in alarm condition and a manual reset via Sitrad or via the interface in the control menu option Reset will be necessary.

If the reset period has elapsed and the number of configured attempts has not occurred, the attempt counter will be reset.



Attention: As a factory default, the suction and discharge alarms are disabled and for their use it is necessary to configure an appropriate limit depending on the application.

Number of attempts = 3

Example 1: Retry interval = 5 minutes

Reset period = 1 hour

In the event of a protection alarm, it will be checked if 3 other alarms of the same type have occurred within the last hour, if so, the pressure switch will be blocked, if not, it will be reset after 5 minutes.

Number of attempts = always

Example 2: Retry interval = 5 minutes

Reset period = 1 hour

In the event of a protection alarm, the pressure switch will be reset after 5 minutes without limit of attempts and the setting of the reset period is indifferent.

18.3 Output signaling

It is possible to configure up to 6 digital alarm outputs through menu 1 . 4 . 5. Each output, when configured, will actuate together with the visual alarm. The activation mode of this alarm output can be switched on or cycling.

Example: Configuring an output through the menu 1.4.5.1.

Pressure switch: Suction 1

Output function: Low pressure

Time on: 5 seconds

Time off: 5 seconds

Digital output = O5 (digital output 5)

In the event of an alarm for suction pressure switch 1, digital output 5 will cycle with Ton and Toff = 5 seconds.

And it will be turned off after leaving the alarm condition, or after the reset.

Example: Configuring an output via the menu 1.4.5.2.

Pressure switch: Suction 1

Output function: Low pressure

Time on: 0 seconds

Time off: 0 seconds

Digital output = O6 (digital output 6)

In the event of a low-pressure alarm on suction 1, output 6 will be activated until manual or automatic reset is carried out.

18.ALARMS

18.4 Alarm tables

18.4.1 System alarms

Alarm	Description	Effect
AL0001	Clock not set	Indicative alarm.
AL0002	PPP	Blocking control functions. Resetting controller parameters.
AL0003	Manual reset record	Indicative alarm.
AL0004	ECAL	Blocking control functions. (Contact Full Gauge Controls).

18.4.2 Suction alarms: The **RCK-862 plus** can control up to 3 suction pressure switches. The address of each pressure switch in the alarm nomenclature is represented by the letter "x". Where "x" can be 1, 2 or 3 and represents suction pressure switches 1, 2 or 3, respectively.

Alarm	Description	Effect
AL0x01	Low pressure	Turns off all compressors on the suction line and fans on the discharge line, regardless of the time set between shutdowns (in case of more than one suction in the group with running compressors, the fans are not turned off). If the function of the menu 1.7.1 - Suction x: Enable Pump Down is set to Yes, one of the compressors remains on until it reaches the Pump Down pressure or the time set for the respective group.
AL0x02	High pressure	Indicative alarm.
AL0x03	Low saturation temperature	Turns off all compressors from the suction line, disregarding the time between shutdowns. If the menu function 1.7.1 - Suction x: Enable Pump Down is configured as Yes, one of the compressors remains on until reaching the pressure or the Pump Down time configured for the respective group.
AL0x04	High saturation temperature	Indicative alarm.
AL0x05	Low secondary fluid inlet temperature	Turns off all compressors from the suction line, disregarding the time between shutdowns. If the menu function 1.7.1 - Suction x: Enable Pump Down is configured as Yes, one of the compressors remains on until reaching the pressure or the Pump Down time configured for the respective group.
AL0x06	High secondary fluid inlet temperature	Indicative alarm.
AL0x07	Low liquid line temperature	Turns off all compressors from the suction line, disregarding the time between shutdowns. If the menu function 1.7.1 - Suction x: Enable Pump Down is configured as Yes, one of the compressors remains on until reaching the pressure or the Pump Down time configured for the respective group.
AL0x08	High liquid line temperature	Indicative alarm.
AL0x09	Critical high liquid line temperature	Disconnect all compressors from the suction pressure switch. Ignores the time between shutdowns.
AL0x10	Low superheating	Indicative alarm.
AL0x11	High superheating	Indicative alarm.
AL0x12	Main pressure sensor fault	It works according to the configuration of menu 1.5 if the sensor is used to control it.
AL0x13	Backup pressure sensor fault	It works according to the configuration of menu 1.5 if the sensor is used to control it.
AL0x14	Liquid line sensor failure	Disable overheat alarms
AL0x15	Reserve liquid line sensor failure	It acts according to the setting in menu 1.5 if it is the sensor used for control.
AL0x16	Temperature failure sensor input of the secondary fluid reserve	It acts according to the setting in menu 1.5 if it is the sensor used for control.
AL0x17	Temperature failure sensor output of the secondary fluid	It acts according to the setting in menu 1.5 if it is the sensor used for control.
AL0x18	Temperature failure sensor output of the secondary fluid reserve	It acts according to the setting in menu 1.5 if it is the sensor used for control.
AL0x19	Failure of any protection sensor of compressor 1 to 6	Indicative alarm.
AL0x20	Compressor safety input 1	Shutts off compressor 1
AL0x21	Compressor safety input 2	Shutts off compressor 2

18.ALARMS

Alarm	Description	Effect
AL0x22	Compressor safety input 3	Shuts off compressor 3
AL0x23	Compressor safety input 4	Shuts off compressor 4
AL0x24	Compressor safety input 5	Shuts off compressor 5
AL0x25	Compressor safety input 6	Shuts off compressor 6
AL0x26	Low pressure digital input (LP)	Turns off all compressors on the suction line and fans on the discharge line, regardless of the time set up between shutdowns (if there is more than one suction line in the group with running compressors, the fans remain on).
AL0x27	High pressure digital input (HP)	Indicative alarm
AL0x28	Compressor 1 maintenance time	Indicative alarm
AL0x29	Compressor 2 maintenance time	Indicative alarm
AL0x30	Compressor 3 maintenance time	Indicative alarm
AL0x31	Compressor 4 maintenance time	Indicative alarm
AL0x32	Compressor 5 maintenance time	Indicative alarm
AL0x33	Compressor 6 maintenance time	Indicative alarm
AL0x34	High temperature in compressor 1	Shuts off the compressor 1
AL0x35	High temperature in compressor 2	Shuts off the compressor 2
AL0x36	High temperature in compressor 3	Shuts off the compressor 3
AL0x37	High temperature in compressor 4	Shuts off the compressor 4
AL0x38	High temperature in compressor 5	Shuts off the compressor 5
AL0x39	High temperature in compressor 6	Shuts off the compressor 6
AL0x40	Pressure sensor reading difference main and reserve	Indicative alarm
AL0x41	Difference in reading of the sensors fluid inlet temperature	Indicative alarm
AL0x42	Difference in reading of the sensors secondary fluid outlet temperature main and reserve	Indicative alarm
AL0x43	External alarm 1	Indicative alarm
AL0x44	External alarm 2	Indicative alarm
AL0x45	External alarm 3	Indicative alarm
AL0x46	External alarm 4	Indicative alarm
AL0x47	External alarm 5	Indicative alarm
AL0x48	External alarm 6	Indicative alarm
AL0x49	External alarm 7	Indicative alarm
AL0x50	External alarm 8	Indicative alarm
AL0x51	External alarm 9	Indicative alarm
AL0x52	External alarm 10	Indicative alarm
AL0x53	External fault 1	Turns off all compressors on the suction line and fans on the discharge line, regardless of the time set up between shutdowns (if there is more than one suction line in the group with running compressors, the fans remain on).
AL0x54	External fault 2	Turns off all compressors on the suction line and fans on the discharge line, regardless of the time set up between shutdowns (if there is more than one suction line in the group with running compressors, the fans remain on).

18.ALARMS

Alarm	Description	Effect
AL0x55	External fault 3	Turns off all compressors on the suction line and fans on the discharge line, regardless of the time set up between shutdowns (if there is more than one suction line in the group with running compressors, the fans remain on).
AL0x56	External fault 4	Turns off all compressors on the suction line and fans on the discharge line, regardless of the time set up between shutdowns (if there is more than one suction line in the group with running compressors, the fans remain on).
AL0x57	External fault 5	Turns off all compressors on the suction line and fans on the discharge line, regardless of the time set up between shutdowns (if there is more than one suction line in the group with running compressors, the fans remain on).
AL0x58	External fault 6	Turns off all compressors from the group's suction lines considering the time between shutdowns. If the menu function 1.7.1 - Suction x: Enable Pump Down is set to Yes, one of the compressors remains on until it reaches the pressure or pump down time set for the respective group.
AL0x59	External fault 7	Turns off all compressors from the group's suction lines, regarding the time between shutdowns. If the menu function 1.7.1 - Suction x: Enable Pump Down is set to Yes, one of the compressors remains on until it reaches the pressure or pump down time set for the respective group.
AL0x60	External fault 8	Turns off all compressors from the group's suction lines considering the time between shutdowns. If the menu function 1.7.1 - Suction x: Enable Pump Down is set to Yes, one of the compressors remains on until it reaches the pressure or pump down time set for the respective group.
AL0x61	External fault 9	Turns off all compressors from the group's suction lines, regarding the time between shutdowns. If the menu function 1.7.1 - Suction x: Enable Pump Down is set to Yes, one of the compressors remains on until it reaches the pressure or pump down time set for the respective group.
AL0x62	External fault 10	Turns off all compressors from the group's suction lines, disregarding the time between shutdowns. If the menu function 1.7.1 - Suction x: Enable Pump Down is set to Yes, one of the compressors remains on until it reaches the pressure or pump down time set for the respective group.

18.ALARMS

18.4.3 Discharge alarms: The **RCK-862 plus** can control up to 3 discharge pressure switches. The address of each pressure switch in the alarm nomenclature is represented by the letter "x". Where "x" can be 4, 5 or 6 and represents discharge pressure switches 1, 2 or 3, respectively.

Example: AL0x01

- 4 - Referring to Discharge 1
- 5 - Referring to Discharge 2
- 6 - Referring to Discharge 3

Alarm	Description	Effect
AL0x01	Low pressure	Shut off all fans on the discharge pressure switch. Ignores the time between deactivations.
AL0x02	High pressure	Turns off all compressors from the group's suction lines considering the time between shutdowns. If the menu function 1.7.1 - Suction x: Enable Pump Down is set to Yes, one of the compressors remains on until it reaches the pressure or pump time down configured for the respective group.
AL0x03	Critical high pressure	Turns off all compressors on the suction line and fans on the discharge line, regardless of the time set between shutdowns (in case of more than one suction in the group with running compressors, the fans are not turned off). If the function of the menu 1.7.1 - Suction x: Enable Pump Down is set to Yes, one of the compressors remains on until it reaches the Pump Down pressure or the time set for the respective group.
AL0x04	Low saturation temperature	Turns off all fans of the discharge pressure switch. Ignore time between shutdowns
AL0x05	High saturation temperature	Turns off all compressors from the group's suction lines considering the time between shutdowns. If the menu function 1.7.1 - Suction x: Enable Pump Down is set to Yes, one of the compressors remains on until it reaches the pressure or pump time down configured for the respective group.
AL0x06	Critical high saturation temperature	Turns off all compressors from the group's suction lines, disregarding the time between shutdowns. If the menu function 1.7.1 - Suction x: Enable Pump Down is configured as Yes, one of the compressors remains on until it reaches the pressure or pump time down configured for the respective group.
AL0x07	Low discharge temperature	Turns off all fans of the discharge pressure switch. Ignore time between shutdowns
AL0x08	High discharge temperature	Turns off all compressors from the group's suction lines considering the time between shutdowns. If the menu function 1.7.1 - Suction x: Enable Pump Down is set to Yes, one of the compressors remains on until it reaches the pressure or pump time down configured for the respective group.
AL0x09	Critical high discharge temperature	Turns off all compressors from the group's suction lines, disregarding the time between shutdowns. If the menu function 1.7.1 - Suction x: Enable Pump Down is configured as Yes, one of the compressors remains on until it reaches the pressure or pump time down configured for the respective group.
AL0x10	Low subcooling	Turn off the fans respecting the time between turning off.
AL0x11	High subcooling	Indicative alarm.
AL0x12	Main pressure sensor fault	Actuates according to the configuration of menu 1.5.
AL0x13	Backup pressure sensor fault	Actuates according to the configuration of menu 1.5.
AL0x14	Main temperatura sensor fault	Actuates according to the configuration of menu 1.5.
AL0x15	Backup temperature sensor fault	Actuates according to the configuration of menu 1.5.
AL0x16	External temperature sensor / dry bulb fault	Adiabatic and floating condensing logic will be disabled.
AL0x17	Wet bulb temperature sensor fault	Differential temperature control is disabled in adiabatic condensation logic.

18.ALARMS

Alarm	Description	Effect
AL0x18	Fan safety input 1	Shut off fan 1
AL0x19	Fan safety input 2	Shut off fan 2
AL0x20	Fan safety input 3	Shut off fan 3
AL0x21	Fan safety input 4	Shut off fan 4
AL0x22	Fan safety input 5	Shut off fan 5
AL0x23	Fan safety input 6	Shut off fan 6
AL0x24	Low pressure digital input (LP)	Shut off all fans on the discharge pressure switch. Ignores the time between shutdowns.
AL0x25	High pressure digital input (HP)	Turns off all the compressors of the suction lines of the group, disregarding the time between shutdowns and turns on all the fans of the discharge line.
AL0x26	Maintenance time for fan 1	Indicative alarm.
AL0x27	Maintenance time for fan 2	Indicative alarm.
AL0x28	Maintenance time for fan 3	Indicative alarm.
AL0x29	Maintenance time for fan 4	Indicative alarm.
AL0x30	Maintenance time for fan 5	Indicative alarm.
AL0x31	Maintenance time for fan 6	Indicative alarm.
AL0x32	Adiabatic condensation validation time	Shut off the adiabatic condensation outlet. This alarm remains active for 1 minute.
AL0x33	Difference between main and backup pressure sensors	Indicative alarm.
AL0x34	Difference between main and backup temperature sensors	Indicative alarm.
AL0x35	External alarm 1	Indicative alarm.
AL0x36	External alarm 2	Indicative alarm.
AL0x37	External alarm 3	Indicative alarm.
AL0x38	External alarm 4	Indicative alarm.
AL0x39	External alarm 5	Indicative alarm.
AL0x40	External alarm 6	Indicative alarm.
AL0x41	External alarm 7	Indicative alarm.
AL0x42	External alarm 8	Indicative alarm.
AL0x43	External alarm 9	Indicative alarm.
AL0x44	External alarm 10	Indicative alarm.
AL0x45	External fault 1	Shut off all fan on the discharge pressure switch. Ignores the time between shutdowns.
AL0x46	External fault 2	Shut off all fan on the discharge pressure switch. Ignores the time between shutdowns.
AL0x47	External fault 3	Shut off all fan on the discharge pressure switch. Ignores the time between shutdowns.
AL0x48	External fault 4	Shut off all fan on the discharge pressure switch. Ignores the time between shutdowns.
AL0x49	External fault 5	Shut off all fan on the discharge pressure switch. Ignores the time between shutdowns.
AL0x50	External fault 6	Shut off all fan on the discharge pressure switch. Respect the time between shutdowns.
AL0x51	External fault 7	Shut off all fan on the discharge pressure switch. Respect the time between shutdowns.
AL0x52	External fault 8	Shut off all fan on the discharge pressure switch. Respect the time between shutdowns.
AL0x53	External fault 9	Shut off all fan on the discharge pressure switch. Respect the time between shutdowns.
AL0x54	External fault 10	Shut off all fan on the discharge pressure switch. Respect the time between shutdowns.

18.ALARMS

18.4.4 Individual pressure switch alarms: The **RCK-862^{plus}** can control up to 3 individual pressure switches. The address of each pressure switch in the alarm nomenclature is represented by the letter "x". Where "x" can be 7, 8 or 9 and represents, respectively, the individual pressure switches 1, 2 or 3.

Example: AL0x01

- 7 - Referring to individual pressure switch 1
- 8 - Referring to individual pressure switch 2
- 9 - Referring to individual pressure switch 3

Alarm	Description	Effect
AL0x01	Low pressure	Indicative alarm.
AL0x02	High pressure	Indicative alarm.
AL0x03	Pressure sensor fault	Shuts off all outputs ignores the time between shutdown.

18.4.5 Individual thermostat alarms: The **RCK-862^{plus}** can control up to 6 individual thermostats. The address of each thermostat in the alarm nomenclature is represented by the letter "x". Where "x" can be 10, 11, 12, 13, 14 and 15, representing the individual thermostats 1, 2, 3, 4, 5 or 6, respectively.

Example: AL0x01

- 10 - Referring to individual thermostat switch 1
- 11 - Referring to individual thermostat switch 2
- 12 - Referring to individual thermostat switch 3
- 13 - Referring to individual thermostat switch 4
- 14 - Referring to individual thermostat switch 5
- 15 - Referring to individual thermostat switch 6

Alarm	Description	Effect
AL0x01	Low temperature	Indicative alarm.
AL0x02	High temperature	Indicative alarm.
AL0x03	Temperature sensor fault	Shut off the output.

18.4.6 Rotating output alarms: The **RCK-862^{plus}** can control up to 3 sets of rotating outputs. The address of each set of rotating outputs in the alarm nomenclature is represented by the letter "x". Where "x" can be 16, 17 and 18, representing sets of outputs 1, 2 or 3, respectively.

Example: AL0x01

- 7 - Referring set of outputs 1
- 8 - Referring set of outputs 2
- 9 - Referring set of outputs 3

Alarm	Description	Effect
ALxx01	Output 1 alarm	Shut off output 1 and actuate output 2
ALxx02	Output 2 alarm	Shut off output 2 and actuate output 1

18.4.7 Communication alarms with expansions:

Alarm	Description	Effect
AL1901	No communication with expansion 1	Shut off all controller outputs (except alarm outputs).
AL1902	No communication with expansion 2	Shut off all controller outputs (except alarm outputs).
AL1903	No communication with expansion 3	Shut off all controller outputs (except alarm outputs).
AL1904	No communication with expansion 4	Shut off all controller outputs (except alarm outputs).
AL1905	No communication with expansion 5	Shut off all controller outputs (except alarm outputs).
AL1906	No communication with expansion 6	Shut off all controller outputs (except alarm outputs).
AL1907	No communication with expansion 7	Shut off all controller outputs (except alarm outputs).
AL1908	No communication with expansion 8	Shut off all controller outputs (except alarm outputs).
AL1909	No communication with expansion 9	Shut off all controller outputs (except alarm outputs).
AL1910	No communication with expansion 10	Shut off all controller outputs (except alarm outputs).

19.MAIN MENU

The Main Menu is accessible by pressing the key  for at least 3 seconds when using the Groups, Suction or Discharge keys.

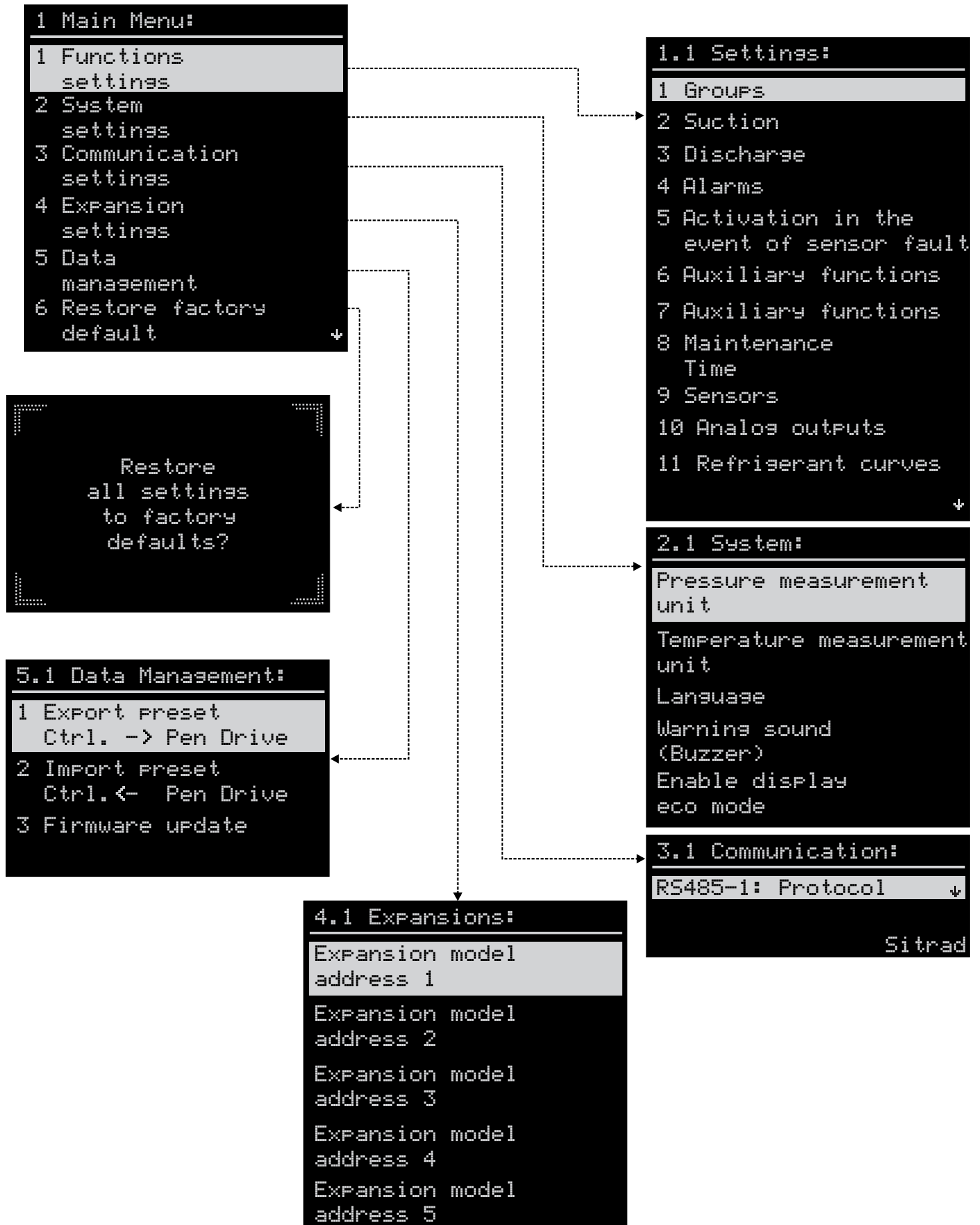

19.1 Functions Settings:

For a complete description of all parameters see chapter 20 - Parameter Table.

19.MAIN MENU

19.2 System settings

Feature	Description	Minimum	Maximum	Standard	Unit
2.1	Pressure measurement unit	Psi	bar	Psi	-
2.2	Temperature measurement unit	°C	°F	°C	-
2.3	Language	Portuguese	Spanish	Portuguese	-
2.4	Warning sound (Buzzer)	Yes	No	Yes	-
2.5	Enable display eco mode	Yes	No	Yes	-

2.1 Pressure measurement unit:

Pressure measurement unit used by the controller: Psi or Bar.

2.2 Temperature measurement unit:

Temperature measurement unit used by the controller: Celsius or Fahrenheit.

2.3 Language:

Controller language: Portuguese, English or Spanish.

2.4 Buzzer:

Enables the audible warning function in case of alarm and controller feedback.

2.5 Enables display eco mode:

Enables display sleep mode. After a period of 15 minutes the display brightness decreases, increasing its life span and decreasing energy consumption.



Note: When ECO mode is active, just a short press on any of the keys will disable it.

19.3 Communication settings:

The **RCK-862 plus** has two independently configurable RS-485 communication ports for communication with the Sitrad software or supervisory ones that use the MODBUS protocol. ie

Feature	Description	Minimum	Maximum	Standard	Unit
3.1	Rs485 - 1: Protocol	0	2	0	-
3.2	Rs485 - 1: Address	1	247	1	-
3.3	RS485 - 1: Baud rate	0	5	5	-
3.4	Rs485 - 1: Parity	0	2	0	-
3.5	RS485 - 1: Stop bits	1	2	1	-
3.6	Rs485 - 2: Protocol	1	2	2	-
3.7	Rs485 - 2: Address	1	247	1	-
3.8	RS485 - 2: Baud rate	0	5	5	-
3.9	Rs485 - 2: Parity	0	2	0	-
3.10	RS485 - 2: Stop bits	1	2	1	-

19.MAIN MENU

3.1 RS485-X/Protocol:

Communication protocol of RS485-X port.

- 0 = Sitrad
- 1 = MODBUS



Note: For communication with FG-HMI 4.3 HMI use Sitrad's protocol.

3.2 RS485-X/Address:

Network address of the RS485-X port. (Available for Sitrad and MODBUS protocols).

3.3 RS485-X/Baud rate:

Communication data rates (Available for the MODBUS protocol only).

- 0 = 4800
- 1 = 9600
- 2 = 19200
- 3 = 38400
- 4 = 57600
- 5 = 115200

3.4 RS485-X/Parity:

Communication protocol parity (Only available for MODBUS protocol).

- 0 = no parity
- 1 = even parity
- 2 = odd parity

3.5 RS485-X/Stop bits:

Number of stop bits (Only available for the MODBUS protocol).

- 1 = 1 stop bit
- 2 = 2 stop bits

19.3.1 Communication with Sitrad:

Communication with the Sitrad Pro software follows the following network structure:

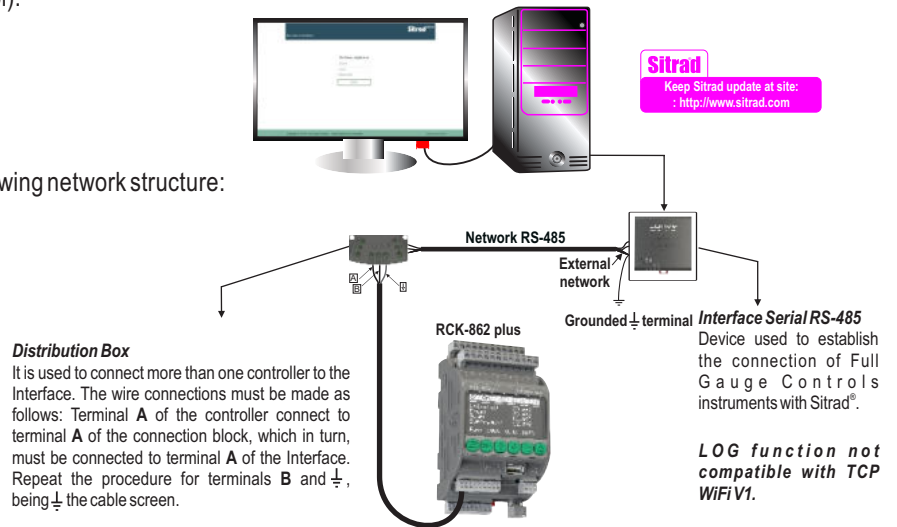

19.3.2 Communication MODBUS:

The **RCK-862 plus** is compatible with the standard MODBUS-RTU protocol. For information on the implemented commands and registration table, contact Full Gauge Controls (e-mail: eng-aplicacao@fullgauge.com.br or phone: (51) 3475-3308).

19.4 Expansions:

The **RCK-862 plus** has the possibility to expand the number of inputs and outputs using expansion modules. This feature allows you to control more complex systems, increasing the number of controlled devices and expanding the possibilities for monitoring and protecting the system.

Through the Exp communication port it is possible to connect up to ten expansion modules, gradually expanding the options of inputs and outputs available to the existing logic. It is recommended to use cables with screens / shields and minimum diameter of 24AWG or (0.5mm) for communication between the expansions and the module.

For example, when using and RCK-461 expansion module, 8 more digital outputs (5 STPS and 3 SSR), 2 0-10V analog outputs, 6 dry contact digital inputs and 8 configurable analog inputs for sensors (NTC or 4-20mA) are added.

To enable communication between the **RCK-862 plus** and the expansion modules, you must configure the desired module in Expansion Model address 1 to 9 (4 . 1 a 4 . 9) and assign the same address to the expansion module. Each expansion module must have an address between 1 to 10, without repeating addresses.

19.MAIN MENU

In each expansion module, an address must be configured between 1 and 10, without repetition. To do this, press the **SET** key for 2 seconds, select the desired address using the keys **↑** and **↓** and press **SET** again to confirm.

On the **RCK-862 plus** the module model used at each address must be selected. To do this, access the menu 4.x, where x represents the address from 1 to 10, and select the corresponding model.

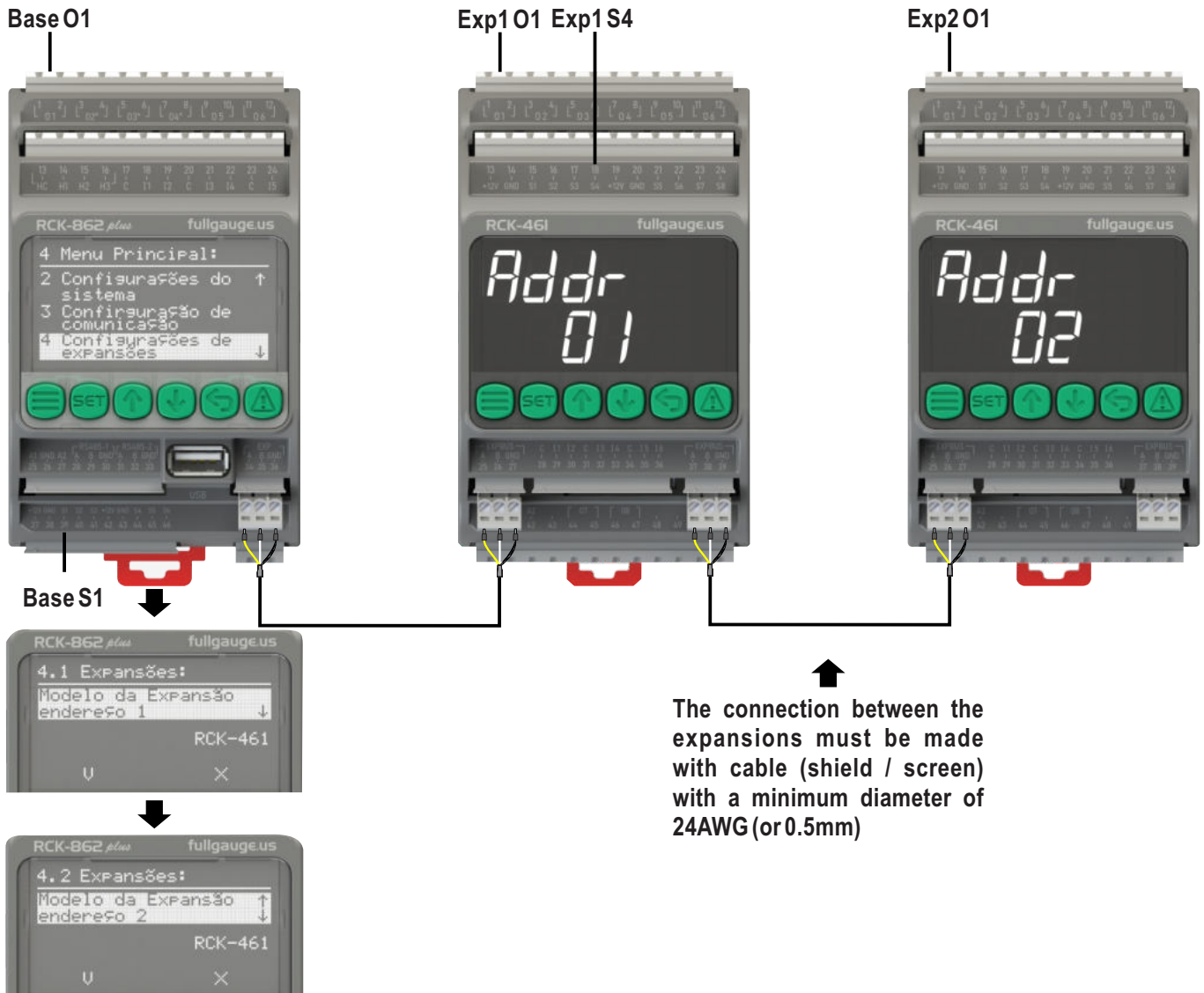

When configuring the expansions, the **RCK-862 plus** automatically expands the possible input and output options for selection.

Example:

```

1.2.1.34 Suction 1:
Compressor 1
Main Output

Base 01
Base 02
...
Base 06
Exp 1 01
...
Exp 1 08
Exp 2 01
...
Exp 2 08
    
```

19.MAIN MENU

19.5 Data management:

The **RCK-862 *plus*** has a USB port with support for communication via pen drive, where it is possible to manage presets and update the controller firmware. Access path: Main Menu → Data manager.

19.5.1 Export preset → RCK-862 *plus* → Pendrive (5.1):

Copies the preset from the controller to the memory of the Pen drive.

The file will be stored in the RCK-862 folder and will be named according to the following logic:

MODEL_AA MM DD_HH MM SS.rec, where:

MODEL = product model, AA = year, MM = month, DD = day, HH = hour, MM = minute, SS = second.

Example: A preset exported on an **RCK-862 *plus***, on 08/02/2019 at 13:30:00 will have the name RCK-862_190802_133000.rec.

19.5.2 Import preset → RCK-862 *plus* → Pendrive (5.1):

Copies the preset from a pen drive to the controller memory.

RCK looks for the preset in the RCK-862 folder. The preset name can be a maximum of 32 characters, including the extension (.rec).

Note: The RCK-862 folder must contain a maximum of 32 preset files.

19.5.3 Firmware update (5.3):

Updates the controller firmware.

The file must be inside the RCK-862 folder and its name must have a maximum of 32 characters, including the extension (.ffg)

Note: The folder must contain a maximum of 32 firmware files.

19.6 Restore factory default:

Restores all parameters to the settings to factory defaults. Access path: Main Menu → 6. Restore Factory Default.



Note: Administrator access level is required to perform this procedure.

Note: To perform this procedure, the control status must be in OFF mode.

20.PARAMETER TABLE

1.1 Groups:

Settings menu related to groups. A group is a set of suction or discharge lines that have links (same refrigerator circuit).

Example: A Rack-type refrigeration system with two suction lines, one for frozen and one for colds, sharing the same discharge line forms a group composed of three pressure switches.

Function	Description	Minimum	Maximum	Standard	Unit
1.1.1	Initial delay	5	999	6	sec
1.1.2	Number of suction pressure switches	0	3	1	-
1.1.3	Number of discharge pressure switches	0	3	1	-
1.1.4	General time between compressor starts	0	60	0	sec
1.1.5	Suction 1 group	1	3	1	-
1.1.6	Suction 2 group	1	3	1	-
1.1.7	Suction 3 group	1	3	1	-
1.1.8	Group 1: Refrigerant fluid	0	24	0	-
1.1.9	Group 2: Refrigerant fluid	0	24	0	-
1.1.10	Group 3: Refrigerant fluid	0	24	0	-
1.1.11	Group 1: Economic setpoint input time	00:00	24:00 [off]	24:00 [off]	hh:mm
1.1.12	Group 1: Economic setpoint output time	00:00	24:00 [off]	24:00 [off]	hh:mm
1.1.13	Group 2: Economic setpoint input time	00:00	24:00 [off]	24:00 [off]	hh:mm
1.1.14	Group 2: Economic setpoint output time	00:00	24:00 [off]	24:00 [off]	hh:mm
1.1.15	Group 3: Economic setpoint input time	00:00	24:00 [off]	24:00 [off]	hh:mm
1.1.16	Group 3: Economic setpoint output time	00:00	24:00 [off]	24:00 [off]	hh:mm
1.1.17	Group 1: Night mode entry time	00:00	24:00 [off]	24:00 [off]	hh:mm
1.1.18	Group 1: Night mode exit time	00:00	24:00 [off]	24:00 [off]	hh:mm
1.1.19	Group 1: Nighttime limit of fans	30	100	100	%
1.1.20	Group 2: Night mode entry time	00:00	24:00 [off]	24:00 [off]	hh:mm
1.1.21	Group 2: Night mode exit time	00:00	24:00 [off]	24:00 [off]	hh:mm
1.1.22	Group 2: Nighttime limit of fans	30	100	100	%
1.1.23	Group 3: Night mode entry time	00:00	24:00 [off]	24:00 [off]	hh:mm
1.1.24	Group 3: Night mode exit time	00:00	24:00 [off]	24:00 [off]	hh:mm
1.1.25	Group 3: Nighttime limit of fans	30	100	100	%
1.1.26	Synchronization between suction 1 and suction 2	0	1	0	-
1.1.27	Synchronization between suction 1 and suction 3	0	1	0	-
1.1.28	Synchronization between suction 2 and suction 3	0	1	0	-

1.1.1 Initial Delay:

It is the time that the controller waits before enabling the pressure switches when the control is activated.

The discharge pressure switches are enabled after the configured time has elapsed.

The suction pressure switches are enabled according to the following logic:

After the initial delay time has elapsed, the pressure switch, with the lowest index, that is capable of being activated (pressure above the setpoint + step) will be enabled;

After the initial delay time has elapsed for the second time, the configured time will enable the next suitable pressure switch;

After the initial delay time has elapsed for the third time, the configured time will enable the last pressure switch.

If there are no suitable pressure switches after the configured time has elapsed, it will be enabled in the sequence, suction 1, suction 2 and suction 3.

The same sequence applies to the individual pressure switches.

20.PARAMETER TABLE

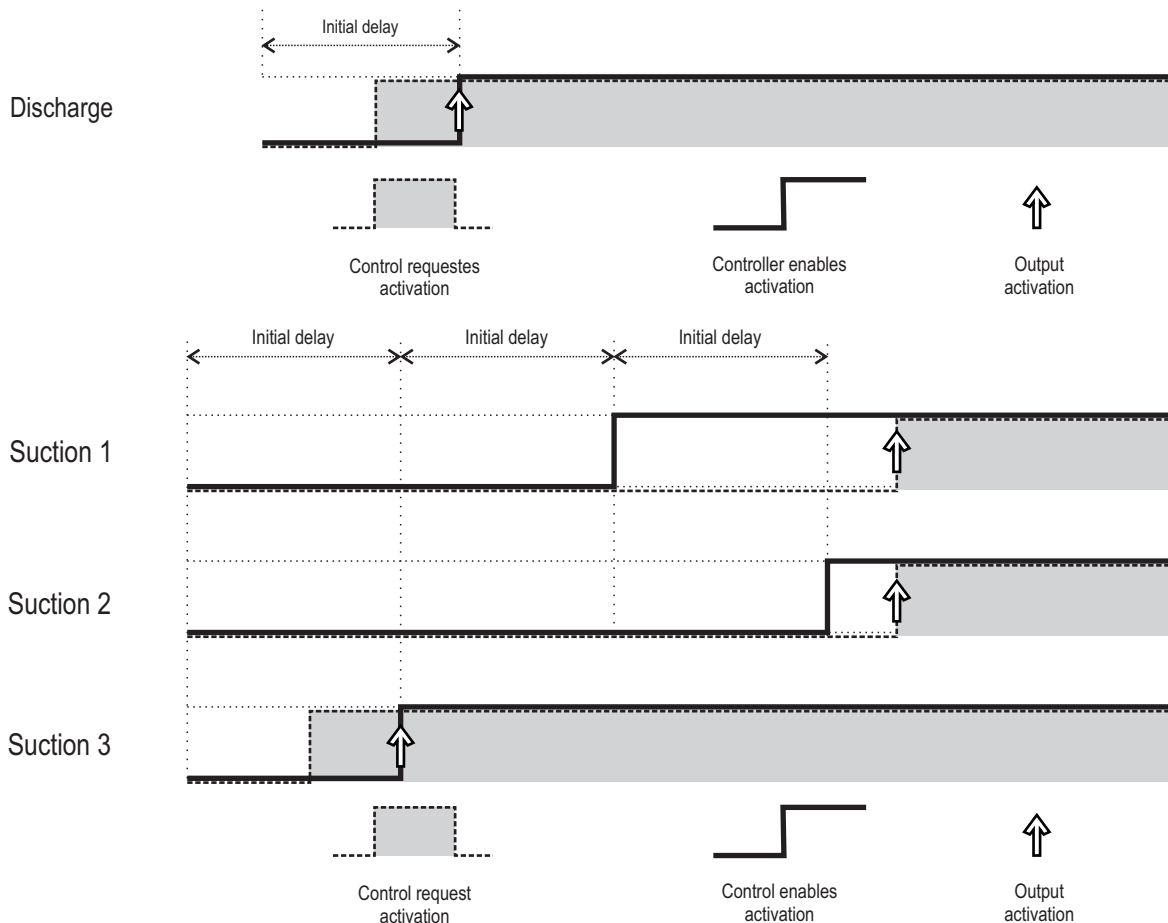

1.1.2 Number of suction pressure switches:

Defines the amount of suction pressure switches that are controlled by the **RCK-862 plus**.

1.1.3 Number of discharge pressure switches:

Defines the amount of discharge pressure switches that will be controlled by the **RCK-862 plus**.

1.1.5 to 1.1.7 Suction group x:

The suction pressure switches are linked with the control groups.

1.1.8 to 1.1.10 Group refrigerant fluid x:

Defines the refrigerant used in the group.

Refrigerant List:

0 = Custom	13 = R427A
1 = R12	14 = R441A
2 = R22	15 = R448A
3 = R32	16 = R449A
4 = R134A	17 = R507A
5 = R290	18 = R513A
6 = R404A	19 = R600A
7 = R407A	20 = R717A
8 = R407C	21 = R744
9 = R407F	22 = R1234YF
10 = R410A	
11 = R422A	
12 = R422D	

1.1.11 / 1.1.13 and 1.1.15 Group x Economic setpoint input time:

Defines the time when the setpoints of the pressure switches belonging to group x is changed to economic mode.

1.1.12 / 1.1.14 and 1.1.16 Group x Economic setpoint output time:

Defines the time when the setpoints of the pressure switches belonging to group x is changed to normal mode.

20.PARAMETER TABLE

1.1.17 Group 1 Night mode entry time:

Sets the time when unload 1 goes into capacity-limited night mode.

1.1.18 Group 1 Night mode exit time:

Sets the time when download 1 exits night mode.

1.1.19 Group 1 Night time limit of fans:

Sets the maximum discharge line capacity value during the night period.

1.1.20 Group 2 Night mode entry time:

Sets the time when flush 2 goes into capacity-limited night mode.

1.1.21 Group 2 Night mode exit time:

Sets the time when download 2 exits night mode.

1.1.22 Group 2 Night time limit of fans:

Sets the maximum discharge line capacity value during the night period.

1.1.23 Group 3 Night mode entry time:

Sets the time when flush 3 goes into capacity-limited night mode.

1.1.24 Group 3 Night mode exit time:

Sets the time when download 3 exits night mode.

1.1.25 Group 3 Night time limit of fans:

Sets the maximum discharge line capacity value during the night period.

1.1.26 Synchronization between suction 1 and suction 2:

Determines the synchronization between the two lines. Before starting line 1, the first compressor in line 2 is activated at minimum capacity and in case of an alarm in line 2, line 1 is switched off.

1.1.27 Synchronization between suction 1 and suction 3:

Determines the synchronization between the two lines. Before starting line 1, the first compressor in line 3 is activated at minimum capacity and in case of an alarm in line 3, the line is switched off.

1.1.28 Synchronization between suction 2 and suction 3:

Determines the synchronization between the two lines. Before starting line 2, the first compressor in line 3 is activated at minimum capacity and in case of an alarm in line 3, line 2 is switched off.

1.2 Suction:

Opens the list of suction pressure switches.

1.2.x Suction x:

List of parameters related to "x" suction pressure switch control. Where x represents suctions 1, 2 or 3.

Function	Description	Minimum	Maximum	Standard	Unit
1.2.x.1	Control mode	0	4	0	-
1.2.x.2	Control type	0	3	0	-
1.2.x.3	Pressure setpoint	0	850,0 (58,6)	20,0 (1,4)	Psi (Bar)
1.2.x.4	Economic pressure setpoint	0	850,0 (58,6)	30,0 (2,1)	Psi (Bar)
1.2.x.5	Hysteresis of On / Off compressors	0	425,0 (29,3)	6,0 (0,4)	Psi (Bar)
1.2.x.6	Hysteresis of the Variable Capacity Compressor (VCC)	0	425,0 (29,3)	10,0 (0,7)	Psi (Bar)
1.2.x.7	Hysteresis of AP control mode	0	425,0 (29,3)	10,0 (0,7)	Psi (Bar)
1.2.x.8	Lower dead zone differential	0	425,0 (29,3)	0	Psi (Bar)
1.2.x.9	Upper dead zone differential	0	425,0 (29,3)	0	Psi (Bar)
1.2.x.10	Minimum pressure setpoint	0	850,0 (58,6)	0	Psi (Bar)
1.2.x.11	Maximum pressure setpoint	0	850,0 (58,6)	850,0 (58,6)	Psi (Bar)
1.2.x.12	Temperature setpoint	-50 (-58,0)	200,0 (392,0)	0,0 (32,0)	°C (°F)
1.2.x.13	Economical temperature setpoint	-50 (-58,0)	200,0 (392,0)	0,0 (32,0)	°C (°F)
1.2.x.14	Hysteresis of compressors On / Off in temperature	0,0 (0,0)	200,0 (360,0)	10,0 (18,0)	°C (°F)
1.2.x.15	Variable capacity compressor hysteresis in temperature	0,0 (0,0)	200,0 (360,0)	10,0 (18,0)	°C (°F)
1.2.x.16	Hysteresis of AP control mode temperatura	0,0 (0,0)	200,0 (360,0)	10,0 (18,0)	°C (°F)
1.2.x.17	Lower dead zone differential temperature	0,0 (0,0)	200,0 (360,0)	10,0 (18,0)	°C (°F)

20.PARAMETER TABLE

Function	Description	Minimum	Maximum	Standard	Unit
1.2.x.18	Upper dead zone differential	0,0 (0,0)	200,0 (360,0)	0,0 (0,0)	°C (°F)
1.2.x.19	Minimum temperature setpoint	-50 (-58,0)	200,0 (392,0)	-50 (-58,0)	°C (°F)
1.2.x.20	Maximum temperature setpoint	-50 (-58,0)	200,0 (392,0)	200,0 (392,0)	°C (°F)
1.2.x.21	Integral time (59 = off)	59 [Off]	999	59 [Off]	sec
1.2.x.22	Critical pressure for shutdown	-14,8 (Off)	850,0 (58,6)	-14,8 (Off)	Psi (Bar)
1.2.x.23	Low pressure for shutdown	-14,8 (Off)	850,0 (58,6)	-14,8 (Off)	Psi (Bar)
1.2.x.24	Suction pressure sensor	0	-	0	-
1.2.x.25	Backup pressure sensor	0	-	0	-
1.2.x.26	Suction pressure sensor	0	-	0	-
1.2.x.27	Secondary fluid inlet temperature sensor	0	-	0	-
1.2.x.28	Reserve secondary fluid inlet temperature sensor	0	-	0	-
1.2.x.29	Secondary fluid outlet temperature sensor	0	-	0	-
1.2.x.30	Backup Secondary Fluid Outlet Temperature Sensor	0	-	0	-
1.2.x.31	Number of compressors	1	6	1	-
1.2.x.32	Compressor 1 - Capacity	1	500	1	kW
1.2.x.33	Compressor 2 - Capacity	1	500	1	kW
1.2.x.34	Compressor 3 - Capacity	1	500	1	kW
1.2.x.35	Compressor 4 - Capacity	1	500	1	kW
1.2.x.36	Compressor 5 - Capacity	1	500	1	kW
1.2.x.37	Compressor 6 - Capacity	1	500	1	kW
1.2.x.38	Compressor 1 - Modulation	0	13	0	-
1.2.x.39	Compressor 2 - Modulation	0	4	0	-
1.2.x.40	Compressor 3 - Modulation	0	4	0	-
1.2.x.41	Compressor 4 - Modulation	0	4	0	-
1.2.x.42	Compressor 5 - Modulation	0	4	0	-
1.2.x.43	Compressor 6 - Modulation	0	4	0	-
1.2.x.44	Compressor 1 - Activation mode	0	2	0	-
1.2.x.45	Compressor 2 - Activation mode	0	2	0	-
1.2.x.46	Compressor 3 - Activation mode	0	2	0	-
1.2.x.47	Compressor 4 - Activation mode	0	2	0	-
1.2.x.48	Compressor 5 - Activation mode	0	2	0	-
1.2.x.49	Compressor 6 - Activation mode	0	2	0	-
1.2.x.50	Actuation sequence	0	1	0	-
1.2.x.51	Shut down sequence	0	1	0	-
1.2.x.52	Compressor 1 - Analog output	0	-	0	-
1.2.x.53	Compressor 1 - Main output	0	-	0	-
1.2.x.54	Compressor 1 - Auxiliary output 1	0	-	0	-
1.2.x.55	Compressor 1 - Auxiliary output 2	0	-	0	-
1.2.x.56	Compressor 1 - Auxiliary output 3	0	-	0	-
1.2.x.57	Compressor 2 - Main output	0	-	0	-
1.2.x.58	Compressor 2 - Auxiliary output 1	0	-	0	-
1.2.x.59	Compressor 2 - Auxiliary output 2	0	-	0	-
1.2.x.60	Compressor 2 - Auxiliary output 3	0	-	0	-
1.2.x.61	Compressor 3 - Main output	0	-	0	-
1.2.x.62	Compressor 3 - Auxiliary output 1	0	-	0	-
1.2.x.63	Compressor 3 - Auxiliary output 2	0	-	0	-
1.2.x.64	Compressor 3 - Auxiliary output 3	0	-	0	-
1.2.x.65	Compressor 4 - Main output	0	-	0	-
1.2.x.66	Compressor 4 - Auxiliary output 1	0	-	0	-
1.2.x.67	Compressor 4 - Auxiliary output 2	0	-	0	-
1.2.x.68	Compressor 4 - Auxiliary output 3	0	-	0	-

20.PARAMETER TABLE

Function	Description	Minimum	Maximum	Standard	Unit
1.2.x.69	Compressor 5 - Main output	0	-	0	-
1.2.x.70	Compressor 5 - Auxiliary output 1	0	-	0	-
1.2.x.71	Compressor 5 - Auxiliary output 2	0	-	0	-
1.2.x.72	Compressor 5 - Auxiliary output 3	0	-	0	-
1.2.x.73	Compressor 6 - Main output	0	-	0	-
1.2.x.74	Compressor 6 - Auxiliary output 1	0	-	0	-
1.2.x.75	Compressor 6 - Auxiliary output 2	0	-	0	-
1.2.x.76	Compressor 6 - Auxiliary output 3	0	-	0	-
1.2.x.77	Time between compressor actuation	1 [off]	9999	5	sec
1.2.x.78	Time between compressor shut down	1 [off]	9999	5	sec
1.2.x.79	Minimum time compressor on	1 [off]	9999	120	sec
1.2.x.80	Minimum time compressor off	1 [off]	9999	120	sec
1.2.x.81	Time between unloaders actuation	1 [off]	999	5	sec
1.2.x.82	Time between unloader shutdown	1 [off]	999	5	sec
1.2.x.83	VCC: Starting time	1[off]	999	5	sec
1.2.x.84	VCC: Validation time bottom	1 [off]	999	999	sec
1.2.x.85	VCC: Validation time upper	1 [off]	999	999	sec
1.2.x.86	VCC - Digital : Minimum capacity	10	50	10	%
1.2.x.87	VCC - Digital : Control period	9 [auto]	120	9 [auto]	sec
1.2.x.88	VCC - Digital : Minimum valve actuation time	2	30	5	sec
1.2.x.89	VCC - Digital : Maximum no-load time	30	181 [off]	120	sec

1.2.x.1 Control mode:

Selection of compressor control mode. Available modes:

- 0 = Linear
- 1 = Rotation
- 2 = Dead zone
- 3 = Dead zine with rotation
- 4 = Progressive Algorithm (compressors of different capacity)



Note: More information about the control modes in the item 14.4.

1.2.x.2 Control type:

Compressor control can be performed by pressure or temperature. In pressure control, the pressure sensor reading, the pressure setpoint and pressure hysteresis will be considered. In the control by saturation temperature, the temperature value resulting from the conversion of the pressure value into the temperature of the corresponding refrigerant will be respective. In this case it uses the temperature setpoint and temperature hysteresis. In the secondary fluid temperature control, the value of a temperature sensor will be considered. (Ex: input or output of a heat exchanger). In this case it uses the temperature setpoint and temperature hysteresis.

- 0 = Pressure
- 1 = Saturation temperature
- 2 = Secondary fluid inlet temperature (FS)
- 3 = Secondary fluid outlet temperature (FS)

1.2.x.3 Pressure setpoint:

Pressure value for suction control where the system shuts down all compressors.

1.2.x.4 Economic pressure setpoint:

Alternative pressure setpoint value, generally higher than the pressure setpoint (1.2.x.3).

1.2.x.5 Hysteresis of On/Off compressors pressure:

It is the pressure range for controlling the On / Off compressors with or without unloaders. This pressure value is related to the setpoint that defines the actuation points for each compressor (actuation interval = setpoint + hysteresis).

Note: This parameter is not used in the Progressive Algorithm control mode.

1.2.x.6 Hysteresis of the Variable Capacity Compressor (VCC pressure:

It is the pressure range for controlling Variable Capacity Compressors (VCC). The compressor modulation is done within this range relative to the setpoint.

Note: This parameter is valid only for Linear and Rotation control modes.

20.PARAMETER TABLE

1.2.x.7 Hysteresis of AP Control Mode pressure:

It is the pressure range that corresponds to all compressors actuated (On / Off and VCC). The reference values for actuation are calculated from the capacity of each compressor.

Note: This parameter is used in the Progressive Algorithm control mode.

1.2.x.8 Lower dead zone differential pressure:

Pressure differential below the setpoint that allows the compressors to be shut down. Used in the Dead zone and Dean Zone with rotation Control modes.

1.2.x.9 Upper dead zone differential pressure:

Pressure differential above the setpoint that allows the compressors to be actuated. Used in the Dead zone and Dead zone with rotation Control modes.

1.2.x.10 Minimum pressure setpoint:

Lowest possible value for adjusting the setpoint. The purpose is to prevent unreasonably low pressures from being regulated by mistake from the normal and economic setpoint.

1.2.x.11 Maximum pressure setpoint:

Highest possible value for setpoint adjustment. The purpose is to prevent unreasonably high pressures from being regulated by mistake from the normal and economic setpoint.

1.2.x.12 Temperature setpoint:

Temperature value for suction control at which the system turns off all compressors.

1.2.x.13 Economical temperature setpoint:

Alternate temperature setpoint value, normally greater than temperature setpoint (1.2.x.12).

1.2.x.14 Hysteresis of On/Off compressors in temperature:

It is the temperature range for controlling On/Off compressors with or without unloaders. This temperature value is relative to the setpoint that defines the trigger points for each compressor (trigger range = setpoint + hysteresis).

Note: This parameter is not used in Progressive Algorithm Control Mode.

1.2.x.15 Variable Capacity Compressor Hysteresis in temperature:

It is the temperature range for controlling Variable Capacity Compressors (VCC). Compressor modulation is done within this range relative to the setpoint.

Note: This parameter is only valid for Linear and Rotation Control Modes.

1.2.x.16 Hysteresis of AP Control Mode temperature:

It is the pressure range that corresponds to all compressors actuated (On / Off and VCC). The reference values for actuation are calculated from the capacity of each compressor.

Note: This parameter is used in the Progressive Algorithm control mode.

1.2.x.17 Lower dead zone differential temperature:

Pressure differential below the setpoint that allows the compressors to be shut down. Used in the Dead zone and Dean Zone with rotation Control modes.

1.2.x.18 Upper dead zone differential temperature:

Pressure differential above the setpoint that allows the compressors to be actuated. Used in the Dead zone and Dead zone with rotation Control modes.

1.2.x.19 Minimum temperature setpoint:

Lowest possible value for adjusting the setpoint. The purpose is to prevent unreasonably low pressures from being regulated by mistake from the normal and economic setpoint.

1.2.x.20 Maximum temperature setpoint::

Highest possible value for setpoint adjustment. The purpose is to prevent unreasonably high pressures from being regulated by mistake from the normal and economic setpoint.

1.2.x.21 Integral time:

When set to a value greater than Off, it enables the Proportional / Integral (PI) control for the compressors. The value of this parameter corresponds to the time in which 100% of the control error is accumulated (suction pressure - setpoint). This value must be configured according to the characteristics of each installation. The higher the value, the slower and more stable the system's behavior. The lower the configured value, the faster and more oscillatory the behavior is.

20.PARAMETER TABLE

1.2.x.22 Critical pressure for shutdown:

Limit pressure value for operation. Below this value, all compressors are turned off (it is recommended to use this function as a safety measure when controlling by temperature). Note: This function is only considered if both 1.2.x.22 and 1.2.x.23 are different from Off.

1.2.x.23 Low pressure for shutdown:

Limit pressure value for operation. Below this value, the activated capacity of the line is proportionally limited with the reduction of pressure until total shutdown when the pressure reaches the value of 1.2.x.22 (it is recommended to use this function as a safety measure when the control is done by temperature). Note: This function is only considered if both 1.2.x.22 and 1.2.x.23 are different from Off.

1.2.x.24 Suction pressure sensor:

Specifies the pressure sensor used for the suction control.

1.2.x.25 Backup pressure sensor:

Specifies the backup pressure sensor used for the suction control. When configured, this sensor automatically takes the suction pressure reading.

1.2.x.26 Suction temperature sensor:

Specifies the suction temperature sensor (refrigerant). When configured, it allows monitoring of the suction line overheating.

1.2.x.27 Secondary fluid inlet temperature sensor:

Specifies the sensor used to measure the temperature of a secondary fluid for control or monitoring.

1.2.x.28 Reserve secondary fluid inlet temperature sensor:

Specifies the backup sensor used to measure the temperature of a secondary fluid for control or monitoring.

1.2.x.29 Secondary fluid outlet temperature sensor:

Specifies the sensor used to measure the temperature of a secondary fluid for control or monitoring.

1.2.x.30 Backup secondary fluid outlet temperature sensor:

Specifies the backup sensor used to measure the temperature of a secondary fluid for control or monitoring.

1.2.x.31 Number of compressors:

Number of compressors used to control suction.



Note: The sensors of the expansion modules will be available after configuring the expansions in menu 4.

1.2.x.32 to 1.2.x.37 Compressor 01-06 capacity:

Compressor capacity in kW. This parameter is used in Control mode by progressive algorithm.

1.2.x.38 to 1.2.x.43 Compressor x modulation:

Configures the type of compressor actuation.

On/Off: On-off compressor that uses only one digital output (relay) for its actuation.

On/Off 50 | 100: Compressor that used two digital outputs (relay) for its actuation. The main output, and an auxiliary output in which each output corresponds to 50% of the compressor capacity.

On/Off 33 | 66 | 100: Compressor that used three digital outputs (relay) for its actuation. The main output and two auxiliary outputs in which each output corresponds to 33% of the compressor capacity.

On/Off 50 | 75 | 100: Compressor that uses three digital outputs (relay) for its actuation. The main output corresponds to 50% of the compressor capacity and each of the two auxiliary outputs corresponds to 25% of the compressor capacity.

On/Off 25 | 50 | 75 | 100: Compressor that uses four digital outputs (relay) for its actuation. The main output corresponds to 25% of the compressor capacity and each of the three auxiliary outputs corresponds to 25% of the compressor capacity.

VCC - Analog: Variable capacity compressor that uses an analog output (0-10V) for its control (available in compressor 01 of each suction line).

Optionally, it is possible to configure a digital output with start / stop function, in the parameter "compressor 1 main output". **Application example:** Compressors using frequency inverters.

VCC - Digital 10-100 1V: Compressor of variable capacity that uses a main output (relay) for its actuation plus an auxiliary output (SSR) for capacity modulation. The compressor's instantaneous capacity is 0% with the auxiliary output on and 100% with the auxiliary output off. **Application example:** Bitzer CR11 compressors.

VCC - Digital 10-100 2V: Variable capacity compressor that uses a main output (relay) for its actuation plus three auxiliary outputs (SSR) for capacity modulation. The compressor's instantaneous capacity is 0% with the two auxiliary outputs on, 50% with an auxiliary output on and 100% with the two auxiliary outputs off. **Application example:** Bitzer CR11 compressors.

20.PARAMETER TABLE

VCC - Digital 10-100 3V: Compressor of variable capacity that uses one main output (relay) for its actuation plus three auxiliary outputs (SSR) for capacity modulation. The compressor's instantaneous capacity is 0% with the three auxiliary outputs on, 33% with two outputs on, 66% with an auxiliary output on and 100% with the three auxiliary outputs off. **Application example:** Bitzer CRII compressors.

VCC - Digital 33-100 1V: Variable capacity compressor that uses a main output (relay) for its actuation plus an auxiliary output (SSR) for capacity modulation. The compressor's instantaneous capacity is 33% with the auxiliary output on and 100% with the auxiliary output off.

VCC - Digital 33-100 2V: Variable capacity compressor that uses a main output (relay) for its activation plus two auxiliary outputs (SSR) for capacity modulation. Compressor instantaneous capacity is 33% with two auxiliary outputs connected, 66% with one output auxiliary on and 100% with both auxiliary outputs off.

VCC - Digital 50-100 1V: Compressor of variable capacity that uses a main output (relay) for its actuation plus an auxiliary output (SSR) for capacity modulation. The compressor's instantaneous capacity is 50% with the auxiliary output on and 100% with the auxiliary output off.

VCC - Digital 10-100 2V_B: Variable capacity compressor that uses a main output (relay) for its activation, and an auxiliary output (SSR) for modulation at 50% of the capacity (aux output 1) and an unloader type auxiliary output at 50% of the capacity (aux output two).

VCC - Digital 10-100 3V_B: Variable capacity compressor that uses a main output (relay) for its activation, a fast auxiliary output (SSR) for modulation at 33% of the capacity (aux output 1) and two unloader type auxiliary outputs at 33% of the capacity each (outputs auxiliaries 2 and 3).

1.2.x.44 to 1.2.x.49 Compressor 01-06 Activation mode:

Parameter that determines the preferred actuation of the compressor outputs that use auxiliary digital outputs. For more information on the unloader actuation modes (auxiliary outputs) see section: 14.2 Compressor Modulation.

- 0 = Incremental Mode
- 1 = Unloader Mode
- 2 = Selective Mode

1.2.x.50 Actuation sequence:

Defines the sequence in which compressors and unloaders are actuated.

- 0 - PPuu (Actuates compressors first and then unloaders);
- 1 - PuPu (Actuates a compressor completely before starting another compressor).

1.2.x.51 Shutdown sequence:

Defines the sequence in which compressors and loaders are shut down.

- 0 - PPuu (shut down unloaders first and then compressors);
- 1 - PuPu (shut down a compressor completely before starting another compressor).

1.2.x.52 Compressor 01 analog output:

Analog output address of compressor 01. This parameter is available if the compressor modulation is VCC-Analog.

- 0 = Not configured
- 1 = A1
- 2 = A2

1.2.x.53, 57, 61, 65, 69, 73 Compressor 01-06 main output:

Compressor xx digital output address.

1.2.x.54, 58, 62, 66, 70, 74 Compressor 01-06 auxiliary output 01:

Compressor xx auxiliary output 01 address.

1.2.x.55, 59, 63, 67, 71, 75 Compressor 01-06 auxiliary output 02:

Compressor xx auxiliary output 02 address.

1.2.x.56, 60, 64, 68, 72, 76 Compressor 01-06 auxiliary output 03:

Compressor xx auxiliary output 03 address.

Digital output address:

- 0 = Not configured
- 1 = Base - O1
- 2 = Base - O2
- 3 = Base - O3
- 4 = Base - O4
- 5 = Base - O5
- 6 = Base - O6

Note: If a sensor already in use is selected, it will be replaced.

1.2.x.77 Time between compressor actuation:

The function applies to the main control outputs of the compressors and is the minimum time between two actuations of the main digital outputs in the suction lines. This time value ensures that no simultaneous actuation of compressors will occur, preventing surges in the supply network and excessive fluctuations in the control pressure.

1.2.x.78 Time between compressor shutdowns:

The function applies to the main control outputs of the compressors and is the minimum time between two shutdowns of the main digital outputs on the suction. This time value guarantees that simultaneous compressor shutdowns will not occur, avoiding electrical variations in the supply network and excessive fluctuations in the control pressure.

1.2.x.79 Minimum time compressor on:

It is the minimum time that the compressor will remain on, that is, time between the last start and the next stop.

1.2.x.80 Minimum time compressor off:

It is the minimum time that the compressor will remain off, that is, the time between the last stop and the next start.

20.PARAMETER TABLE

1.2.x.81 Time between unloaders actuations:

It is the time interval between the actuation of two auxiliary digital outputs (unloaders) of the same compressor.

Example: In a compressor with modulation 0 | 33 | 66 | 100 that uses one main and two auxiliary outputs. The time between actuating two auxiliary outputs. The time between actuating two auxiliary outputs (66 and 100%) must be greater than the time between actuating unloaders.

1.2.x.82 Time between unloader shutdown:

It is the time interval between shutting down two auxiliary digital outputs (unloaders) from the same compressor.

Example: In a compressor with modulation 0 | 33 | 66 | 100 that uses one main and two auxiliary outputs. The time between shutdowns of two auxiliary outputs (66 and 100%) must be greater than the time between shutdowns of unloaders.

1.2.x.83 VCC-Startup time:

It is the time that the Variable Capacity Compressor remains in the starting condition. For the VCC-Analog compressor the analog output takes the value configured in (1.10.x.3) but if the control calculates a demand greater than the starting value, the required value will be applied.

The VCC-Digital compressor operates without load during the start-up time, that is, with a capacity equal to zero.

1.2.x.84 VCC-Lower validation time:

This time is a validation of the need to disable a next stage of compression and avoid unnecessary shutdowns. When VCC compressor reaches the minimum value, where the control would immediately deactivate or activate a next compression stage (On/Off compressor or unloaders valve), the control starts to wait this time to validate the transition and take the next action.

1.2.x.85 VCC-Upper validation time:

This time is a validation of the need to activate a next stage of compression and avoid unnecessary triggers. When the VCC compressor reaches its maximum value, where the control would immediately trigger a next compression stage (On/Off compressor or unloaders valve), the control starts to wait for this time to validate the transition and take the next action.

1.2.x.86 VCC-Digital/Minimum capacity:

Sets a minimum value for the capacity of the digital variable capacity compressor.

1.2.x.87 VCC-Digital/Control period:

Configures the fixed modulation signal period for the Digital Variable Capacity Compressor. When set to the default value (auto) the period is automatically calculated by the control algorithm.

1.2.x.88 VCC-Digital/Minimum valve actuation time:

Sets the minimum time that the valves of the VCC-Digital compressors must remain on or off during modulation.

1.2.x.89 VCC-Digital/Maximum no-load time:

Maximum time that the Digital Variable Capacity Compressor remains in operation at minimum capacity or with auxiliary outputs on, resulting in a capacity equal to zero. After this time has elapsed, one of the auxiliary outputs is switched off for the same time value as configured in this parameter, causing the compressor to operate at a higher capacity.

Note: This function works even during the start-up time, so it is recommended to use a start-up time, lower than the maximum no-load time.

Note: This function is only available for compressors with VCC-Digital modulation 10-100 1V, 2V and 3V.

1.3 Discharge:

Opens the list of discharge pressure switches.

1.3.x Discharge x:

List of parameters related to the control of the discharge pressure switch "x". Where x represents discharges 1, 2 or 3.

Function	Description	Minimum	Maximum	Standard	Unit
1.3.x.1	Control mode	0	3	0	-
1.3.x.2	Control type	0	2	0	-
1.3.x.3	Pressure setpoint	0	850,0 (58,6)	100,0 (6,9)	Psi (Bar)
1.3.x.4	Economic pressure setpoint	0	850,0 (58,6)	80,0 (5,5)	Psi (Bar)
1.3.x.5	Digital outputs Hysteresis	0	425,0 (29,3)	10,0 (0,7)	Psi (Bar)
1.3.x.6	Analog output Hysteresis	0	425,0 (29,3)	10,0 (0,7)	Psi (Bar)
1.3.x.7	Lower dead zone differential	0	425,0 (29,3)	0	Psi (Bar)
1.3.x.8	Upper dead zone	0	425,0 (29,3)	0	Psi (Bar)
1.3.x.9	Minimum setpoint pressure	0	850,0 (58,6)	0	Psi (Bar)
1.3.x.10	Maximum setpoint pressure	0	850,0 (58,6)	850,0 (58,6)	Psi (Bar)
1.3.x.11	Temperature setpoint	0	200,0 (392,0)	60 (140,0)	°C (F)
1.3.x.12	Economic temperature setpoint	0	200,0 (392,0)	50 (122,0)	°C (F)
1.3.x.13	Digital output hysteresis	0	200,0 (392,0)	10 (18,0)	°C (F)

20.PARAMETER TABLE

Function	Description	Minimum	Maximum	Standard	Unit
1.3.x.14	Analog output hysteresis	0	200,0 (392,0)	10 (18,0)	°C (F)
1.3.x.15	Lower dead zone limit	0	200,0 (392,0)	0 (0)	°C (F)
1.3.x.16	Upper dead zone limit	0 (0)	200,0 (392,0)	0 (0)	°C (F)
1.3.x.17	Minimum temperature setpoint	0 (32)	200,0 (392,0)	0 (32)	°C (F)
1.3.x.18	Maximum temperature setpoint	0 (32)	200,0 (392,0)	200 (392,0)	°C (F)
1.3.x.19	Discharge pressure sensor	0	-	0	-
1.3.x.20	Backup pressure sensor	0	-	0	-
1.3.x.21	Liquid line temperature sensor	0	-	0	-
1.3.x.22	Reserve liquid line temperature sensor	0	-	0	-
1.3.x.23	External temperature sensor (TBS)	0	-	0	-
1.3.x.24	Number of fans	0	6	1	-
1.3.x.25	Fan 1 Modulation	0	1	0	-
1.3.x.26	Fan 1 Analog output	0	-	0	-
1.3.x.27	Fan 1 Digital output	0	-	0	-
1.3.x.28	Fan 2 Digital output	0	-	0	-
1.3.x.29	Fan 3 Digital output	0	-	0	-
1.3.x.30	Fan 4 Digital output	0	-	0	-
1.3.x.31	Fan 5 Digital output	0	-	0	-
1.3.x.32	Fan 6 Digital output	0	-	0	-
1.3.x.33	Minimum time between actuations	1 [off]	9999	5	sec
1.3.x.34	Minimum time between shutdowns	1 [off]	9999	5	sec
1.3.x.35	Minimum time fan on	1 [off]	9999	30	sec
1.3.x.36	Minimum time fan off	1 [off]	9999	30	sec
1.3.x.37	Analog output start time	1 [off]	999	10	sec
1.3.x.38	Analog output validation time	1 [off]	999	20	sec
1.3.x.39	Integral time	59 [off]	999	59 [off]	sec

1.3.x.1 Control Mode:

Selection of the fan control mode. Available modes:

- 0 = Linear
- 1 = Rotation
- 2 = Dead zone
- 3 = Dead zone with rotation

1.3.x.2 Control type:

The discharge control can be carried out by pressure or temperature.

In pressure control, the pressure sensor, pressure setpoint and pressure hysteresis will be considered.

Temperature control will consider the temperature sensor, temperature setpoint and temperature hysteresis

Note: Calculation of the subcooling only available when the control type is by pressure.

- 0 = Pressure
- 1 = Temperature saturation
- 2 = Liquid line temperature

1.3.x.3 Pressure setpoint:

Pressure value for controlling the discharge in which the system shuts down all fans.

1.3.x.4 Economic pressure setpoint:

Alternative pressure setpoint value, usually less than the pressure setpoint (1.3.x.3).

1.3.x.5 Pressure hysteresis of digital outputs:

It is pressure range for controlling the fans linked with the digital outputs. This pressure value is related to the setpoint that defines the actuation points for each fan (activation interval = setpoint + hysteresis).

1.3.x.6 Analog output Hysteresis:

It is pressure range for controlling the fan linked with the analog output. The modulation of the analog output is within this range related to the setpoint. This parameter is valid only for Linear and Rotation control modes.

20.PARAMETER TABLE

1.3.x.7 Lower dead zone differential (pressure):

Pressure differential, below the setpoint that allows the compressors to be shut off. Used in the Dead zone and Dead zone with rotation control modes.

1.3.x.8 Upper dead zone differential (pressure):

Pressure differential, above the setpoint that allows the compressors to be actuated. Used in the Dead zone and Dead zone with rotation control modes.

1.3.x.9 Minimum pressure setpoint:

Lowest possible value for setpoint adjustment. The purpose is to prevent unreasonably low pressures from being regulated by mistake from the normal and economic setpoint.

1.3.x.10 Maximum pressure setpoint:

Highest possible value for setpoint adjustment. The purpose is to prevent unreasonably high pressures from being regulated by mistake from the normal and economic setpoint.

1.3.x.11 Temperature setpoint:

Temperature value for controlling the discharge in which the system shuts off all fans.

1.3.x.12 Economic temperature setpoint:

Alternative temperature setpoint value, usually lower than the pressure setpoint (1.3.x.11).

1.3.x.13 Digital outputs Hysteresis:

It is the temperature range for controlling the fans linked with the digital outputs. This pressure value is related to the setpoint that defines the actuation points for each fan (actuation interval = setpoint + hysteresis).

1.3.x.14 Analog output hysteresis:

It is the temperature range for controlling the fan linked with the analog output. The modulation of the analog output is within this range related to the setpoint. This parameter is valid only for Linear and Rotation control modes.

1.3.x.15 Lower dead zone limit (temperature):

Lower limit whose purpose is to avoid that, by mistake, excessively low temperatures are regulated from the normal and economic setpoint.

1.3.x.16 Upper dead zone limit (temperature):

Upper limit whose purpose is to avoid that, by mistake, excessively high temperatures are regulated from the normal and economic setpoint.

1.3.x.17 Minimum temperature setpoint:

Lowest possible value for setpoint adjustment. The purpose is to avoid that, by mistake, excessively low temperatures are set from the normal and economic setpoint.

1.3.x.18 Maximum temperature setpoint:

Highest possible value for setpoint adjustment. The purpose is to avoid that, by mistake, excessively high temperatures are set from the normal and economic setpoint.

1.3.x.19 Discharge pressure sensor:

Specifies the pressure sensor used to control the discharge.

1.3.x.20 Backup pressure sensor:

Specifies the backup pressure sensor used to control the discharge.

When configured, this sensor automatically takes the discharge pressure reading.

1.3.x.21 Liquid line temperature sensor:

Liquid line temperature sensor address.

When configured, it allows monitoring of the discharge line overheating.

1.3.x.22 Reserve liquid line temperature :

Address of the reserve liquid line temperature sensor.

When configured, this sensor automatically takes the discharge of the liquid line sensor.

1.3.x.23 External temperature sensor (TBS):

Specifies the dry air bulb temperature sensor.

1.3.x.24 Number of fans:

Number of fans used to control the discharge.

Sensor options
0 = Not configured
1 = Base - S1
2 = Base - S2
3 = Base - S3
4 = Base - S4
5 = Base - S5
6 = Base - S6



Note: The sensors present in the expansion modules will be listed in menu 4 after their configuration.

20.PARAMETER TABLE

1.3.x.25 Fan 1 Modulation:

Fan 1 modulation type is selected: ON | OFF (digital output) or INVERTER (analog output). It is possible to configure an output with start / stop function to operate together with the analog. To do this, just configure the "digital output of fan 1".

- 0 = No modulation
- 1 = Inverter

1.3.x.26 Fan 1 Analog output:

Analog output address for fan 1 inverter.

- 0 = Not configured
- 1 = Base - A1
- 2 = Base - A2

1.3.x.27 to 1.3.x.32 Fan 01 to 06 Digital output:

Digital output address of fan 1 to 6.

- 0 = Not configured
- 1 = Base - O1
- 2 = Base - O2
- 3 = Base - O3
- 4 = Base - O4
- 5 = Base - O5
- 6 = Base - O6



Note: The outputs present in the expansion modules will be listed in menu 4 after their configuration.

1.3.x.33 Minimum time between starts:

The function applies to the main control outputs of the fans and is the minimum time between two actuations of the main digital outputs at discharge. This time guarantees that simultaneous fan actuations will not occur, preventing surges in the supply network and excessive fluctuations in the control variable.

1.3.x.34 Minimum time between shutdowns:

The function applies to the main control outputs of the fans and is the minimum time between two shutdowns of the main digital outputs. This time ensures that simultaneous fan shutdowns will not occur, preventing electrical surges in the supply network and excessive fluctuations in the control pressure.

1.3.x.35 Minimum time fan on :

It is the minimum time the fan will remain on, that is, the time between the last start and the next stop.

1.3.x.36 Minimum time fan off:

It is the minimum time that the fan will remain off, that is, the time between the last start and the next stop.

1.3.x.37 Analog output starting time:

It is the time that the analog output remains at the starting value. If the control calculates a demand greater than the starting value, the required value will be applied.

1.3.x.38 Analog output validation time:

This time is a validation of the need to actuate or shutdown a next ventilation stage and avoid unnecessary fan actuation or shutdown. When reaching the minimum or maximum value, where the control would immediately shut down or actuate a next fan, the control will wait for this time to validate the transition and take the next action.

1.3.x.39 Integral time:

When configured, it enables the Proportional / Integral (PI) control of the fans. The value of this parameter corresponds to the time in which 100% of the control error (hysteresis-setpoint) is accumulated. This value must be configured according to the characteristics of each system. The higher the value, the slower and more stable the system's behavior. The lower the configured value, the faster and more oscillatory the behavior is.

20.PARAMETER TABLE

1.4 Alarms:

Parameters related to alarm settings.

1.4.1 Alarm settings:

Function	Description	Minimum	Maximum	Standard	Unit
1.4.1.1	Time to validate alarms	0	9999	5	sec
1.4.1.2	Alarm inhibition time	0	9999	5	sec
1.4.1.3	Difference between pressure sensors	0 [Off]	850,0 (58,6)	0 [Off]	Psi (bar)
1.4.1.4	Difference between temperature sensors	0 [Off]	200,0 (360,0)	0 [Off]	°C (°F)

1.4.1.1 Time to validate alarms:

It is the time between the moment when the controller identified an alarm condition and its indication.

1.4.1.2 Alarm inhibition time:

It is the time when the alarm events are considered after the controller is energized.

1.4.1.3 Difference between pressure sensors:

Difference between main and backup pressure sensor readings to generate alarm.

1.4.1.4 Difference between temperature sensors:

Difference between main and backup temperature sensor readings to generate alarm.

1.4.2 Suction alarms:

Alarms are assigned separately for each suction pressure switch. In this list, select the suction to which you want to configure the alarms.

1.4.2.x Suction alarms:

If configured with the OFF parameter, alarms are not enabled.

The letter "x" represents suctions 1, 2 and 3.

Function	Description	Minimum	Maximum	Standard	Unit
1.4.2.x.1	Low pressure	-14,8 [off] (-1,1)	850,0 (58,6)	-14,8 [off] (-1,1)	Psi (Bar)
1.4.2.x.2	High pressure	-14,7 (-1,0)	850,1 [off] (58,7)	850,1 [off] (58,7)	Psi (Bar)
1.4.2.x.3	Hysteresis of pressure alarms	1,0 (0,1)	425,0 (29,3)	1,0 (0,1)	Psi (Bar)
1.4.2.x.4	Low saturation temperature	-50,1 [off] (-58,2)	200,0 (392,0)	-50,1 [off] (-58,2)	°C (°F)
1.4.2.x.5	High saturation temperature	-50,0 (-58,0)	200,1 [off] (392,2)	200,1 [off] (392,2)	°C (°F)
1.4.2.x.6	Low secondary fluid inlet temperature	-50,1 [off] (-58,2)	200,0 (58,6)	-50,1 [off] (-58,2)	°C (°F)
1.4.2.x.7	High secondary fluid inlet temperature	-50,0 (-58,0)	200,1 [off] (392,2)	200,1 [off] (392,2)	°C (°F)
1.4.2.x.8	Low secondary fluid outlet temperature	-50,1 [off] (-58,2)	200,0 (58,6)	-50,1 [off] (-58,2)	°C (°F)
1.4.2.x.9	High secondary fluid outlet temperature	-50,0 (-58,0)	200,1 [off] (392,2)	200,1 [off] (392,2)	°C (°F)
1.4.2.x.10	Critical overheating	-0,1 [off] (-0,2)	50,0 (90,0)	-0,1 [off] (-0,2)	°C (F)
1.4.2.x.11	Low overheating	-0,1 [off] (-0,2)	50,0 (90,0)	-0,1 [off] (-0,2)	°C (F)
1.4.2.x.12	High overheating	0,0	50,1 [off] (90,2)	50,1 [off] (90,2)	°C (F)
1.4.2.x.13	Hysteresis of temperature alarms	0,3 (0,5)	200,0 (360,0)	5,0 (9,0)	°C (F)

1.4.2.x.1 Low pressure:

Enables the alarm when the pressure is lower than the configured value.

1.4.2.x.2 High pressure:

Enables the alarm when the pressure is higher than the configured value.

1.4.2.x.3 Hysteresis of pressure alarms:

It is pressure difference to get out of the alarm situation.

1.4.2.x.4 Low saturation temperature:

Enables the alarm when the temperature is higher than the configured value. Difference between temperature sensors.

1.4.2.x.5 High saturation temperature:

Enables the alarm when the temperature is lower than the configured value.

1.4.2.x.6 Low secondary fluid inlet temperature:

Enables the alarm when the superheat is greater than the configured value.

20.PARAMETER TABLE

1.4.2.x.7 High secondary fluid inlet temperature:

Enables the alarm when the pressure is lower than the configured value.

1.4.2.x.8 Low secondary fluid outlet temperature:

Enables the alarm when the pressure is greater than the configured value.

1.4.2.x.9 High secondary fluid outlet temperature:

Enables the alarm when the pressure is lower than the configured value.

1.4.2.x.10 Critical overheating:

Enables the alarm when the temperature is lower than the configured value. This value is usually lower than the low overheating value (1.4.x.5).

1.4.2.x.11 Low overheating:

Enables the alarm when the temperature is lower than the configured value.

1.4.2.x.12 High overheating:

Enables the alarm when the overheating is higher than the configured value.

1.4.2.x.13 Hysteresis of temperature alarms:

It is the temperature variation necessary to get out of the alarm situation.

1.4.3 Discharge alarms:

1.4.3.x Discharge alarms - discharge 1 to 3

The letter x represents discharges 1, 2 and 3.

Function	Description	Minimum	Maximum	Standard	Unit
1.4.3.x.1	Low pressure	-14,8 [off] (-1,1)	850,0 (58,6)	-14,8 [off] (-1,1)	Psi (Bar)
1.4.3.x.2	High pressure	-14,7 (-1,0)	850,1 [off] (58,7)	850,1 [off] (58,7)	Psi (Bar)
1.4.3.x.3	Critical high pressure	-14,7 (-1,0)	850,1 [off] (58,7)	850,1 [off] (58,7)	Psi (Bar)
1.4.3.x.4	Hysteresis of pressure alarms	1,0 (0,1)	425,0 (29,3)	1,0 (0,1)	Psi (Bar)
1.4.3.x.5	Low saturation temperature	-50,1 [off] (-58,2)	200,0 (392,0)	-50,1 [off] (-58,2)	°C (F)
1.4.3.x.6	High saturation temperature	-50,0 (-58,0)	200,1 (392,2)	200,1 [off] (392,2)	°C (F)
1.4.3.x.7	Critical high saturation temperature	-50,0 (-58,0)	200,1 [off] (392,2)	200,1 [off] (392,2)	°C (F)
1.4.3.x.8	Low liquid line temperature	-50,1 [off] (-58,2)	200,0 (392,0)	-50,1 [off] (-58,2)	°C (F)
1.4.3.x.9	High liquid line temperature	-50,0 [off] (-58,0)	200,1 (392,2)	200,1 [off] (392,2)	°C (F)
1.4.3.x.10	Critical high liquid line temperature	-50,0 (-58,0)	200,1 [off] (392,2)	200,1 [off] (392,2)	°C (F)
1.4.3.x.11	Low subcooling	-0,1 [off] (-0,2)	20,0 (36,0)	-0,1 [off] (-0,2)	°C (F)
1.4.3.x.12	High subcooling	0,0	200,1 [off] (360,2)	200,1 [off] (360,2)	°C (F)
1.4.3.x.13	Hysteresis of temperature alarms	0,3 (0,5)	200,0 (360,0)	5,0 (9,0)	°C (F)

1.4.3.x.1 Low pressure:

Enables the alarm when the pressure is lower than the configured value.

1.4.3.x.2 High pressure:

Enables the alarm when the pressure is higher than the configured value.

1.4.3.x.3 Critical high pressure:

Enables the alarm when the pressure is higher than the configured value. Generally higher than the value set in the high-pressure alarm (1.4.3.x.2).

1.4.3.x.4 Hysteresis of pressure alarms:

It is the pressure difference to get out of the alarm situation.

1.4.3.x.5 Low saturation temperature:

Enables the alarm when the temperature is lower than the configured value.

1.4.3.x.6 High saturation temperature:

Enables the alarm when the temperature is higher than the configured value.

1.4.3.x.7 Critical high saturation temperature:

Enables the alarm when the temperature is higher than the configured value. It is usually greater than the value configured in the high temperature alarm (1.4.3.x.6).

20.PARAMETER TABLE

1.4.3.x.8 Low liquid line temperature:

Enables the alarm when the temperature is lower than the configured value.

1.4.3.x.9 High liquid line temperature:

Enables the alarm when the temperature is higher than the configured value.

1.4.3.x.10 Critical high liquid line temperature:

Enables the alarm when the temperature is higher than the configured value. It is usually greater than the value configured in the high temperature alarm (1.4.3.x.6).

1.4.3.x.11 Low subcooling:

Enables the alarm when the subcooling is lower than the configured value.

1.4.3.x.12 High subcooling:

Enables the alarm when the subcooling is higher than the configured value.

1.4.3.x.13 Hysteresis of temperature alarms:

It is the temperature variation necessary to get out of the alarm situation.

1.4.4 Reset:

Automatic reset settings for each suction and discharge line.

Function	Description	Minimum	Maximum	Standard	Unit
1.4.4.1	Number of attempts	0 [off]	11 [ever]	0	-
1.4.4.2	Retry interval	1	60	15	min
1.4.4.3	Reset period	1	24	1	h

1.4.4.1 Number of attempts:

Number of automatic reset attempts made within the Reset period (1.4.4.3).

1.4.4.2 Interval between attempts:

Time interval between two subsequent attempts of automatic reset.

1.4.4.3 Reset period:

This feature allows you to adjust the time for the number of automatic reset attempts (1.4.4.1). If all automatic resets have already been carried out within the time set in this feature and another fault occurs, the **RCK-862_{plus}** controller only resumes operation with a manual reset.

1.4.5.x Output x:

The **RCK-862_{plus}** has up to six configurable alarm outputs. For each output, a specific alarm on the control lines can be linked and the output can be configured to cycle on and off or only on in the event of an alarm.

The letter x represents alarm outputs 1 to 6.

Function	Description	Minimum	Maximum	Standard	Unit
1.4.5.x.1	Suction / discharge pressure switch	0	9	0	-
1.4.5.x.2	Output function	0	31	0	-
1.4.5.x.3	Time on	0	999	0	sec
1.4.5.x.4	Time off	0	999	0	sec
1.4.5.x.5	Digital output	0	-	0	-
1.4.5.x.6	Contact type NO - NC	0	1/NC	0 [no]	-

1.4.5.x.1 Suction / discharge pressure switch:

Associates the alarm output to one of the lines:

- 0 = Off
- 1 = Suction 1
- 2 = Suction 2
- 3 = Suction 3
- 4 = Discharge 1
- 5 = Discharge 2
- 6 = Discharge 3
- 7 = Group 1
- 8 = Group 2
- 9 = Group 3

20. PARAMETER TABLE

1.4.5.x.2 Output function:

The alarm output is linked with one of the following alarm events:

0 = Off	13 = Any temperature alarm	28 = Wet bulb temperature sensor fault
1 = Any alarm	14 = Digital input	29 = Compressor temperature sensor fault
2 = Low pressure	15 = Awaiting manual reset	30 = Fault in any sensor
3 = High pressure	16 = Critical overheating	31 = Stop by alarm
4 = Critical high pressure	17 = Low overheating	
5 = Any pressure alarm	18 = High overheating	
6 = Low pressure	19 = Any overheating alarm	
7 = High pressure	20 = Low subcooling	
8 = High critical temperature	21 = High subcooling	
9 = Fluid inlet temperature secondary low	22 = Any subcooling alarm	
10 = Fluid inlet temperature high secondary	23 = Pressure sensor fault	
11 = Outlet fluid temperature secondary low	24 = Temperature sensor fault	
12 = Outlet fluid temperature high secondary	25 = Temperature sensor failure secondary fluid inlet	
	26 = Temperature sensor failure secondary fluid outlet	
	27 = Dry bulb temperature sensor fault	

1.4.5.x.3 Time on:

Time that the output remains actuated in an alarm event.

1.4.5.x.4 Time off:

Time the output remains shutdown in an alarm event. When this time is set to OFF, the output will be activated if there is an alarm condition.

1.4.5.x.5 Digital output:

Digital output address for alarm.

0 = Not configured	4 = Base - O4
1 = Base - O1	5 = Base - O5
2 = Base - O2	6 = Base - O6
3 = Base - O3	

Note: If a sensor already in use is selected, it will be replaced.

1.4.5.x.6 Contact type:

Output polarity.

0 - NO: When the output is actuated, the contact is closed;

1 - NC: When the output is actuated, the contact is open.

1.5 Actuation in case of sensor fault:

It allows configuring the status of each compressor or fan (on, off or cycling) in a sensor fault condition that measures the suction pressure or the discharge pressure / temperature. This logic serves to keep the system in emergency operation in the event of a sensor fault.

If a backup sensor is configured, this mode will only start if the main and backup sensors are faulty.

The letter x represents suction (x between 1 and 3) and discharges (x between 4 and 6).

Function	Description	Minimum	Maximum	Standard	Unit
1.5.x.1	Compressor 1	0 [off]	200	0 [off]	%
1.5.x.2	Compressor 2	0 [off]	2/Cycling	0 [off]	-
1.5.x.3	Compressor 3	0 [off]	2/Cycling	0 [off]	-
1.5.x.4	Compressor 4	0 [off]	2/Cycling	0 [off]	-
1.5.x.5	Compressor 5	0 [off]	2/Cycling	0 [off]	-
1.5.x.6	Compressor 6	0 [off]	2/Cycling	0 [off]	-
1.5.x.7	Time on for cycle timer	1	60	5	min
1.5.x.8	Time off for cycle timer	1	60	5	min

20.PARAMETER TABLE

1.5.x.1 Compressor/ventilador 01:

The status of the compressor in case of sensor failure is set.

VCC compressor:

0: Compressor or fan completely off.

1 to 100: Compressor or fan connected with a fixed capacity by the value 1 to 100, respecting the values of maximum and minimum operating capacity.

101 to 200: Compressor or fan cycling according to times 1.5.x.7 and 1.5.x.8. The operating capacity is defined by the configured value - 100. Ex: Configured value = 150. capacity = 150 - 100 = 50%. The operating capacity respects the maximum and minimum operating capacity values.

Compressor On/Off:

0: Compressor or fan completely off.

1: Compressor or fan fully on (100% capacity).

2 or higher: Compressor is cycling.

1.5.x.2 to 1.5.x.6 Compressor/ventilador 02 to 06:

The compressor status in case of sensor fault is defined:

Off: Compressor or fan completely off.

On: Compressor or fan fully on (100% capacity).

Cyclic: Compressor or fan cycling according to times 1.5.x.7 and 1.5.x.8.

Example: Output 01 = on / Output 02 = off / Output 03 = on / Output 04 = Cyclic / Output 05 = Cyclic / Output 06 = off.

In this case, compressors 1 and 3 will always remain on, compressors 2 and 6 will remain off and compressors 4 and 5 remain cycling. This condition will be maintained until the problem is corrected (connection or replacement of the sensor).

1.5.x.7 Time on for cycle timer:

Time that the compressor or fan remains on.

1.5.x.8 Time off for cycle timer:

Time that the compressor or fan remains off.

1.6 Auxiliary inputs:

It allows configuring up to 8 auxiliary inputs with specific functions.

The letter "x" represents digital inputs 1 to 30.

1.6.1 Input x:

Function	Description	Minimum	Maximum	Standard	Unit
1.6.x.1	Use link	0	17	0	-
1.6.x.2	Input function	0	34	0	-
1.6.x.3	Digital input address	0	-	0	-
1.6.x.4	NO-NC contact type	0[no]	1 / NC	0[no]	-

1.6.x.1 Use Link:

Links input x with a pressure switch, group, or auxiliary function according to:

0 = Off	4 = Discharge 1	8 = Group 1 suction	12 = Group 3 suction	16 = Rotation outputs 3
1 = Suction 1	5 = Discharge 2	9 = Group 2	13 = All pressure switches	17 = All outputs
2 = Suction 2	6 = Discharge 3	10 = Group 2 suction	14 = Rotation outputs 1	
3 = Suction 3	7 = Group 1	11 = Group 3	15 = Rotation outputs 2	

1.6.x.2 Input function:

Input x can have different functions linked with its actuation and shutdown according to:

- **None:** Function not configured, with no effect.

- **Safety input X:** For Suction and Discharge: Immediately disconnect the compressor or fan x (1 to 6) from the associated suction or discharge line. Records an alarm event.

For Caster output sets: Safety input 1 turns off output 1, Safety input 2 turns off output 3 and Safety input 3 turns off the operating output and Turns on the other output. Records an alarm event.

- **Economic setpoint:** Changes the setpoint to economic.

- **Actuates all outputs:** Actuates all compressors of the linked suction or discharge line. If an alarm occurs, this command is canceled.

- **Shutdown all outputs:** Shuts down all compressors or fans of the linked pressure switch.

- **Low Pressure (LP):** On suction, in normal operation, it has the same effect as the low pressure alarm and takes control of the compressors in the event of a control sensor failure. On discharge it has the same effect as the low-pressure alarm.

- **High Pressure (HP):** In suction it has the same effect as the high pressure alarm. On discharge, it has the same effect as the critical high pressure alarm.

- **Activates Pump Down:** Activates the Pump Down shutdown function.

- **Enables adiabatic condensation:** Enables adiabatic condensation control.

20.PARAMETER TABLE

- **Enables floating condensation:** Enables floating condensation control.
- **Virtual alarm:** Visual alarm input linked with the suction or discharge line.
- **External alarm 1 to 10:** Visual alarm.
- **External fault 1 to 5:** Alarm that shuts down all the compressors or fans of the configured suction or discharge line.
- **External fault 6 to 10:** Alarm that switches off all the compressors or fans of the configured suction or discharge line, respecting the time between shutdowns.

- 0 = None
- 1 = Safety input 1 (Available for 1.6.x.1 = 1 to 6, 14, 15, 16)
- 2 = Safety input 2 (Available for 1.6.x.1 = 1 to 6, 14, 15, 16)
- 3 = Safety input 3 (Available for 1.6.x.1 = 1 to 6, 14, 15, 16)
- 4 = Safety input 4 (Available for 1.6.x.1 = 1 to 6)
- 5 = Safety input 5 (Available for 1.6.x.1 = 1 to 6)
- 6 = Safety input 6 (Available for 1.6.x.1 = 1 to 6)
- 7 = Actuates economic setpoint (Available for 1.6.x.1 = 1 to 13)
- 8 = Turn on all outputs (Available for 1.6.x.1 = 1 to+ 12)
- 9 = Shutdown off all outputs (Available for any value off 1.6.x.1)
- 10 = Low pressure (LP) (Available for 1.6.x.1 = 1 to 6)
- 11 = High pressure (HP) (Available 1.6.x.1 = 1 to 6)
- 12 = Actuates Pump Down (Available for 1.6.x.1 = 1 to 3, 7 to 13)
- 13 = Actuates adiabatic condensation (Available for 1.6.x.1 = 4 to 6, 7, 9, 11, 13)
- 14 = Actuates floating condensation (Available for 1.6.x.1 = 4 to 6, 7, 9, 11, 13)
- 15 = External alarm 1 (Available for 1.6.x.1 = 1 to 13)
- 16 = External alarm 2 (Available for 1.6.x.1 = 1 to 13)
- 17 = External alarm 3 (Available for 1.6.x.1 = 1 to 13)
- 18 = External alarm 4 (Available for 1.6.x.1 = 1 to 13)
- 19 = External alarm 5 (Available for 1.6.x.1 = 1 to 13)
- 20 = External alarm 6 (Available for 1.6.x.1 = 1 to 13)
- 21 = External alarm 7 (Available for 1.6.x.1 = 1 to 13)
- 22 = External alarm 8 (Available for 1.6.x.1 = 1 to 13)
- 23 = External alarm 9 (Available for 1.6.x.1 = 1 to 13)
- 24 = External alarm 10 (Available for 1.6.x.1 = 1 to 13)
- 25 = External fault 1 (Available for 1.6.x.1 = 1 to 13)
- 26 = External fault 2 (Available for 1.6.x.1 = 1 to 13)
- 27 = External fault 3 (Available for 1.6.x.1 = 1 to 13)
- 28 = External fault 4 (Available for 1.6.x.1 = 1 to 13)
- 29 = External fault 5 (Available for 1.6.x.1 = 1 to 13)
- 30 = External fault 6 (Available for 1.6.x.1 = 1 to 13)
- 31 = External fault 7 (Available for 1.6.x.1 = 1 to 13)
- 32 = External fault 8 (Available for 1.6.x.1 = 1 to 13)
- 33 = External fault 9 (Available for 1.6.x.1 = 1 to 13)
- 34 = External fault 10 (Available for 1.6.x.1 = 1 to 13)

1.6.x.3 Address of the digital input:

Links the address of the physical digital input with input x.

- 0 = Not configured
- 1 = Base - HI1
- 2 = Base - HI2
- 3 = Base - HI3
- 4 = Base - I1
- 5 = Base - I2
- 6 = Base - I3
- 7 = Base - I4
- 8 = Base - I5



Note: The inputs present in the expansion modules will be listed in menu 4 after their configuration.

1.6.x.4 Contact type NO-NC:

Actuation status at the input. NO is actuated via a normally open contact and NC is actuated via a normally closed contact.

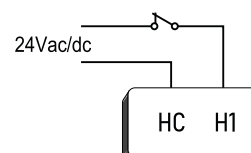
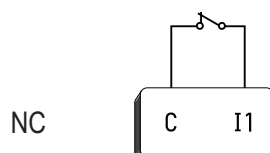
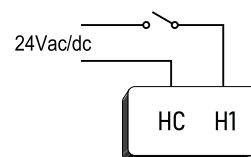
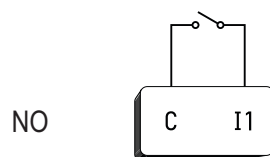

20.PARAMETER TABLE

1.7 Auxiliary functions:

1.7.1 Pump Down:

Function	Description	Minimum	Maximum	Standard	Unit
1.7.1.x.1	Group 1: Shutdown pressure	-14,7 (-1,0)	850,0 (58,6)	5,0 (0,3)	Psi (Bar)
1.7.1.x.2	Group 1: Maximum shutdown time	1	9999	30	sec
1.7.1.x.3	Group 1: Enables Pump Down	0 [no]	1 [yes]	0 [no]	-
1.7.1.x.4	Group 1: Digital output	0	-	0	-
1.7.1.x.5	Group 1: Contact type NO-NC	0 [NO]	1/ NC	0 [no]	-
1.7.1.x.6	Group 2: Shutdown pressure	-14,7 (-1,0)	850,0 (58,6)	5,0 (0,3)	Psi (Bar)
1.7.1.x.7	Group 2: Maximum shutdown time	1	9999	30	sec
1.7.1.x.8	Group 2: Enables Pump Down	0 [no]	1 [yes]	0 [no]	-
1.7.1.x.9	Group 2: Digital output	0	-	0	-
1.7.1.x.10	Group 2: Contact type NO-NC	0 [NO]	1/ NC	0 [no]	-
1.7.1.x.11	Group 3: Shutdown pressure	-14,7 (-1,0)	850,0 (58,6)	5,0 (0,3)	Psi (Bar)
1.7.1.x.12	Group 3: Maximum shutdown time	1	9999	30	sec
1.7.1.x.13	Group 3: Enables Pump Down	0 [no]	1 [yes]	0 [no]	-
1.7.1.x.14	Group 3: Digital output	0	-	0	-
1.7.1.x.15	Group 3: Contact type NO-NC	0 [NO]	1/ NC	0 [não]	-
1.7.1.x.16	Suction 1: Enables Pump Down	0 [no]	1 [yes]	0 [no]	-
1.7.1.x.17	Suction 1: Digital output	0	-	0	-
1.7.1.x.18	Suction 1: Contact type NO-NC	0 [NO]	1/ NC	0 [no]	-
1.7.1.x.19	Suction 2: Enables Pump Down	0 [no]	1 [yes]	0 [no]	-
1.7.1.x.20	Suction 2: Digital output	0	-	0	-
1.7.1.x.21	Suction 2: Contact type NO-NC	0 [NO]	1/ NC	0 [no]	-
1.7.1.x.22	Suction 3: Enables Pump Down	0 [no]	1 [yes]	0 [no]	-
1.7.1.x.23	Suction 3: Digital output	0	-	0	-
1.7.1.x.24	Suction 3: Contact type NO-NC	0 [NO]	1/ NC	0 [no]	-

1.7.1.x.1, 6 and 11 Group x: Shutdown pressure:

Pressure value indicating that the fluid has been completely withdrawn and the compressors are turned off.

1.7.1.x.2, 7 and 12 Group x: Maximum shutdown time:

Maximum time allowed for fluid collection. After this time has elapsed, the compressors are turned off.

1.7.1.x.3, 8 and 13 Group x: Enables Pump Down:

Enables the Pump Down shutdown function.

1.7.1.x.4, 9 and 14 Group x: Digital output:

Address digital output.

20.PARAMETER TABLE

1.7.1.x.5, 10 and 15 Group x: NO-NC contact type:

State of actuation on entry. NO is actuated via a normally open contact and NC is actuated via a normally closed contact.

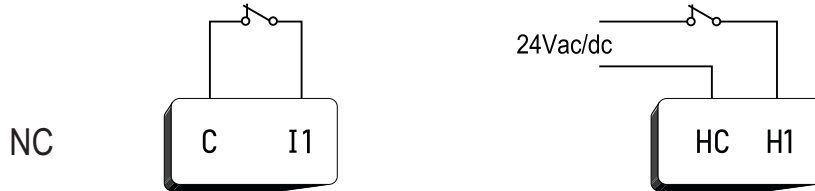

1.7.1.x.16, 19 and 22 Suction x: Enables Pump Down:

Enables shutdown with fluid collection in suction 1. In case of shutdown condition (setpoint or defrost) the last compressor remains in operation until it reaches the shutdown pressure or the maximum time of the group associated with this suction line.

1.7.1.x.17, 20 and 23 Suction x: Digital output:

Digital output address. The Pump Down digital output associated with a suction line can be used to inform the expansion valve controller that a defrost will be performed and that the valve can be closed or to actuate a fluid blocking solenoid.

1.7.1.x.18, 21 and 24 Suction x: Contact type NO-NC:

State of actuation on entry. NO is actuated via a normally open contact and NC is actuated via a normally closed contact.

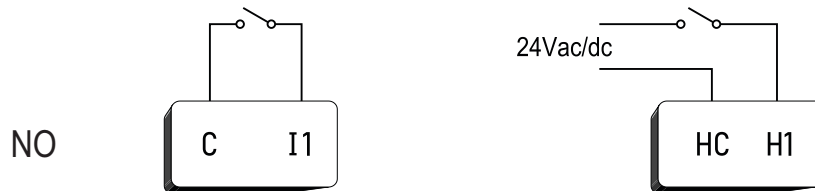

20.PARAMETER TABLE

1.7.2. x Compressor protection thermostat:

The letter x represents compressors 1 to 6 for each suction line.

Suction 1: x between 1 and 6.

Suction 2: x between 7 and 12.

Suction 3: x between 13 and 18.

Function	Description	Minimum	Maximum	Standard	Unit
1.7.2.x.1	Output control temperature	0 (32,0)	200,1 [off] (392,2)	200,1 [off] (392,2)	°C (F)
1.7.2.x.2	Compressor shutdown temperature	0 (32,0)	200,1 [off] (392,2)	200,1 [off] (392,2)	°C (F)
1.7.2.x.3	Hysteresis	0,1 (0,2)	200,0 (360,0)	5,0 (9)	°C (F)
1.7.2.x.4	Temperature sensor	0	-	0	-
1.7.2.x.5	Digital output	0	-	0	-

1.7.2.x.1 Output control temperature:

Control temperature value for actuating the cooling output.

1.7.2.x.2 Compressor shutdown temperature:

Temperature value for compressor shutdown and alarm indication.

1.7.2.x.3 Hysteresis:

It is the temperature range for controlling the fans linked with the digital outputs. This pressure value is related to the setpoint that defines the actuation points for each fan (actuation interval = setpoint + hysteresis).

1.7.2.x.4 Temperature sensor:

Address of the temperature sensor that measures the temperature of the compressor

0 = Not configured	4 = Base - S4
1 = Base - S1	5 = Base - S5
2 = Base - S2	6 = Base - S6
3 = Base - S3	



Note: The sensors present in the expansion modules will be listed in menu 4 after their configuration.

1.7.2.x.5 Digital output:

Digital output address controlled by the protection thermostat.

0 = Not configured	4 = Base - O4
1 = Base - O1	5 = Base - O5
2 = Base - O2	6 = Base - O6
3 = Base - O3	



Note: The outputs present in the expansion modules will be listed in menu 4 after their configuration.

1.7.3. x Adiabatic Condensation:

The letter x represents discharges 1 to 3.

Function	Description	Minimum	Maximum	Standard	Unit
1.7.3.x.1	Control mode	0	3	0	-
1.7.3.x.2	Temperature for actuation	-50,1 (-58,2)	200,1 [off] (392,2)	-50,1 (-52,2)	°C (F)
1.7.3.x.3	Temperature for shutdown	-50,1 (-58,2)	200,1 (392,2)	-50,1 (-52,2)	°C (F)
1.7.3.x.4	Differential for actuation	0 (0)	25,1 (45,2)	0 (0)	°C (F)
1.7.3.x.5	Differential for shutdown	0 (0)	25,1 (45,2)	25,1 (45,2)	°C (F)
1.7.3.x.6	Minimum operating temperature (TBS)	-50,0 (-58,0)	200,0 (392,0)	18,0 (64,4)	°C (F)
1.7.3.x.7	Differential validation time	1	999	30	min
1.7.3.x.8	Time for next attempt	1	999	30	min
1.7.3.x.9	Wet bulb temperature sensor (TBU)	0	-	0	-
1.7.3.x.10	Digital output	0	-	0	-
1.7.3.x.11	Time on	1	999	5	min
1.7.3.x.12	Time off	1	999	5	min
1.7.3.x.13	Start time	00:00	24:00 [off]	1440 [off]	hh:mm
1.7.3.x.14	End time	00:00	24:00 [off]	1440 [off]	hh:mm

1.7.3.x.1 Control mode:

Configures the operation mode according to:

0 = Off	2 = Cycle timer
1 = By temperature	3 = Temperature with cycle timer

20.PARAMETER TABLE

1.7.3.x.2 Temperature for actuation:

Temperature of the dry bulb sensor to actuate the output.

1.7.3.x.3 Temperature for shutdown:

Temperature of the external temperature sensor (TBS) for shutting down the output.

1.7.3.x.4 Differential for actuation:

Value of the difference between dry and wet bulb temperatures for actuating the output.

1.7.3.x.5 Differential for shutdown:

Value of the difference between dry and wet bulb temperatures for shutting down the output.

1.7.3.x.6 Minimum operating temperature (TBS):

Minimum ambient temperature for adiabatic condensation operation for differential control.

1.7.3.x.7 Differential validation time:

Maximum time to reach the shutdown differential (1.7.3.x.4).

1.7.3.x.8 Time for next attempt:

Time that the control waits before actuating the output for a new attempt to reach the shutdown differential

1.7.3.x.9 Wet bulb temperature sensor (TBS):

Specifies the wet bulb temperature sensor.

1.7.3.x.10 Digital output:

Digital output address

Sensor addresses:

0 = Not configured

1 = Base - O1

2 = Base - O2

3 = Base - O3

4 = Base - O4

5 = Base - O5

6 = Base - O6

Sensor options:

0 = Not configured

1 = Base - S1

2 = Base - S2

3 = Base - S3

4 = Base - S4

5 = Base - S5

6 = Base - S6



Note: The sensors present in the expansion modules will be listed in menu 4 after their configuration.

1.7.3.x.11 Time on:

Time length the output remains on in Cycle Timer Mode and Temperature with cycle timer.

1.7.3.x.12 Time off:

Time length the output remains off in Cycle Timer Mode and Temperature with cycle timer.

1.7.3.x.13 Start time:

Logic operating start time.

1.7.3.x.14 End time:

Logic operating end time.



Note: If parameters 1.7.3.x.13 and 1.7.3.x.14 are set to OFF, the adiabatic condensation will remain active.

1.7.4.1 Floating condensation:

The letter x represents discharges 1 to 3.

Feature	Description	Minimum	Maximum	Standard	Unit
1.7.4.x.1	Fluctuation start temperature	-50,1 [off] (-58,2)	200,0 (392,2)	-50,1 [off] (-58,2)	°C (F)
1.7.4.x.2	Minimum safety setpoint	-14,7 (-1,0)	850,0 (58,6)	250,0 (17,2)	Psi (Bar)
1.7.4.x.3	Safety subcooling	0 (0)	200,0 (360,0)	1,0 (1,8)	°C (F)
1.7.4.x.4	Start time	00:00 [off]	24:00 [off]	24:00 [off]	hh:mm
1.7.4.x.5	End time	00:00 [off]	24:00 [off]	24:00 [off]	hh:mm

1.7.4.x.1 Fluctuation start temperature:

Temperature value for starting control of the discharge setpoint. Floating condensation operates below this value.

1.7.4.x.2 Minimum safety setpoint:

Minimum value of the pressure setpoint for the discharge.

20.PARAMETER TABLE

1.7.4.x.3 Safety sub-cooling:

Minimum subcooling value. At this point, the setpoint reduction is stopped.

1.7.4.x.4 Start time

Logic operating start time.

1.7.4.x.5 End time:

Logic operating end time.



Note: If parameters 1.7.4.x.4 and 1.7.4.x.5 are set to OFF, adiabatic condensation will remain active.



Attention: If a dry bulb temperature sensor has been configured for adiabatic condensation, it is not necessary to configure this parameter.

1.7.5.1 Individual pressure switches:

The letter x represents individual pressure switches 1 to 3.

Feature	Description	Minimum	Maximum	Standard	Unit
1.7.5.x.1	Operation Mode	0	2	0	-
1.7.5.x.2	Pressure setpoint 1	0	850,0 (58,6)	10,0 (0,7)	Psi (Bar)
1.7.5.x.3	Pressure setpoint 2	0	850,0 (58,6)	20,0 (1,4)	Psi (Bar)
1.7.5.x.4	Pressure setpoint 3	0	850,0 (58,6)	30,0 (2,1)	Psi (Bar)
1.7.5.x.5	Pressure setpoint 4	0	850,0 (58,6)	40,0 (2,8)	Psi (Bar)
1.7.5.x.6	Pressure setpoint 5	0	850,0 (58,6)	50,0 (3,4)	Psi (Bar)
1.7.5.x.7	Pressure setpoint 6	0	850,0 (58,6)	60,0 (4,1)	Psi (Bar)
1.7.5.x.8	Pressure hysteresis 1	0	425,0 (29,3)	10,0 (0,7)	Psi (Bar)
1.7.5.x.9	Pressure hysteresis 2	0	425,0 (29,3)	10,0 (0,7)	Psi (Bar)
1.7.5.x.10	Pressure hysteresis 3	0	425,0 (29,3)	10,0 (0,7)	Psi (Bar)
1.7.5.x.11	Pressure hysteresis 4	0	425,0 (29,3)	10,0 (0,7)	Psi (Bar)
1.7.5.x.12	Pressure hysteresis 5	0	425,0 (29,3)	10,0 (0,7)	Psi (Bar)
1.7.5.x.13	Pressure hysteresis 6	0	425,0 (29,3)	10,0 (0,7)	Psi (Bar)
1.7.5.x.14	Pressure sensor	0	-	0	-
1.7.5.x.15	Digital output address 1	0	-	0	-
1.7.5.x.16	Digital output address 2	0	-	0	-
1.7.5.x.17	Digital output address 3	0	-	0	-
1.7.5.x.18	Digital output address 4	0	-	0	-
1.7.5.x.19	Digital output address 5	0	-	0	-
1.7.5.x.20	Digital output address 6	0	-	0	-
1.7.5.x.21	Low pressure alarm	-14,8 [off] (-1,1)	850,0 (58,6)	-14,8 [off] (-1,1)	Psi (Bar)
1.7.5.x.22	High pressure alarm	0	850,1 [off] (58,7)	850,1 [off] (58,7)	Psi (Bar)
1.7.5.x.23	Hysteresis of alarms	1 (0,1)	20 (13,8)	1 (0,1)	Psi (Bar)
1.7.5.x.24	Minimum time between actuations	1 [off]	9999	5	sec
1.7.5.x.25	Minimum output on time	1 [off]	9999	5	sec

1.7.5.x.1 Operation mode:

Configures the Operation Mode.

0-Off

1-Compression

2-Descompression

1.7.5.x.2 to 1.7.5.x.7 Pressure setpoint 01-06:

Output pressure setpoint 01-06.

1.7.5.x.8 to 1.7.5.x.13 Pressure hysteresis 01-06:

Hysteresis of output 01-06.

1.7.5.x.14 Pressure sensor:

Specifies the pressure sensor.

Sensor options:

0 = Not configured 4 = Base - S4

1 = Base - S1 5 = Base - S5

2 = Base - S2 6 = Base - S6

3 = Base - S3



Note: The sensors present in the expansion modules will be listed in menu 4 after their configuration.

20.PARAMETER TABLE

1.7.5.x.15 to 1.7.5.x.20 Address of digital output 01-06:

Digital output address 01-06 linked to the individual pressure switch.

1.7.5.x.21 Low pressure alarm:

Enables the alarm indication when the pressure is lower than the configured value.

1.7.5.x.22 High pressure alarm:

Enables the alarm indication when the pressure is higher than the configured value.

1.7.5.x.23 Alarm hysteresis:

Hysteresis of pressure alarms.

1.7.5.x.24 Minimum time between activations:

The function applies to the main control outputs of the individual pressure switches and is the minimum time between two actuations of the main digital outputs. This time guarantees that simultaneous activation of the digital outputs will not occur, avoiding surges in the supply network and excessive fluctuations in the control variable.

1.7.5.x.25 Minimum output time on:

Minimum output time on/off.

1.7.6 Individual thermostat:

The letter x represents individual thermostats 1 to 3.

Feature	Description	Minimum	Maximum	Standard	Unit
1.7.6.x.1	Operation mode	0	2	0	-
1.7.6.x.2	Temperature setpoint	-50,0 (-58,0)	200,0 (39,2)	20,0 (68,0)	°C (°F)
1.7.6.x.3	Temperature hysteresis	1,0 (1,8)	5,0 (9,0)	5,0 (9,0)	°C (°F)
1.7.6.x.4	Low temperature alarm	-50,1 (-58,2)	200,0 (392,0)	-50,1 (-58,2)	°C (°F)
1.7.6.x.5	High temperature alarm	-50,0 (-58,0)	200,1 (392,2)	200,1 (392,2)	°C (°F)
1.7.6.x.6	Hysteresis of alarms	1,0 (1,8)	5,0 (9,0)	5,0 (9,0)	°C (°F)
1.7.6.x.7	Linked pressure switch	0	3		-
1.7.6.x.8	Temperature sensor	0	*		-
1.7.6.x.9	Main output	0	*		-
1.7.6.x.10	Contact type: NO-NC (main)	0	1	0	-
1.7.6.x.11	Minimum time output on / off	1	9999		sec
1.7.6.x.12	Defrost output	0	*		-
1.7.6.x.13	Contact type: NO-NC (defrost)	0	1	0	-
1.7.6.x.14	Interval between defrosts	0	9999	240	Min
1.7.6.x.15	Defrost length	0	9999	30	Min
1.7.6.x.16	Defrost time 1	0	00:00	24:00	Min
1.7.6.x.17	Defrost time 2	0	00:00	24:00	Min
1.7.6.x.18	Defrost time 3	0	00:00	24:00	Min
1.7.6.x.19	Defrost time 4	0	00:00	24:00	Min
1.7.6.x.20	Defrost time 5	0	00:00	24:00	Min
1.7.6.x.21	Defrost time 6	0	00:00	24:00	Min

1.7.6.x.1 Operation mode:

Configures the Operation Mode.

- 0 = Off
- 1 = Heating
- 2 = Cooling

1.7.6.x.2 Temperature setpoint:

Output temperature setpoint.

1.7.6.x.3 Temperature hysteresis:

Temperature control hysteresis linked to individual thermostat output.

1.7.6.x.4 Low pressure alarm:

Enables the alarm indication when the temperature is lower than the configured value.

1.7.6.x.5 High pressure alarm:

Enables the alarm indication when the temperature is higher than the configured value.

20.PARAMETER TABLE

1.7.6.x.6 Alarm hysteresis:

Hysteresis of temperature alarms.

1.7.6.x.7 Linked pressure switch:

Allows you to link the thermostat to a suction pressure switch.

0 = Suction 1

1 = Suction 2

2 = Suction 3

1.7.6.x.8 Temperature sensor:

Specifies the temperature sensor.

1.7.6.x.9 Main output address:

Output address linked to the individual thermostat.

1.7.6.x.10 NO-NC contact type:

Defines the actuation state of the main output

0 = NO: When the output is actuated, the contact is closed.

1 = NC: When the output is actuated, the contact is open.

1.7.6.x.11 Minimum time output on:

Minimum time output on/off.

1.7.6.x.12 Defrost output address:

Output address linked to the individual thermostat to defrost.

1.7.6.x.13 Contact type NO-NC (defrost):

Defines the operating state of the defrost output.

0 = NO: When the output is actuated, the contact is closed.

1 = NC: When the output is actuated, the contact is open.

1.7.6.x.14 Interval between defrosts:

Time interval between the defrosts.

1.7.6.x.15 Defrost length:

Time interval during which the thermostat remains in defrost.

1.7.6.x.16 to 1.7.6.x.21 Defrost time:

It allows configuring a specific time to defrost. In this case, the defrost interval parameter will not be considered.

1.7.7 Rotation outputs:

Function	Description	Minimum	Maximum	Standard	Unit
1.7.7.x.1	Rotation outputs time	0	9999	720	min.
1.7.7.x.2	Transition time	0	9999	5	sec.
1.7.7.x.3	Compressor start time	0	9999	5	sec.
1.7.7.x.4	Digital output 1 address	0	-	0	-
1.7.7.x.5	Digital output 2 address	0	-	0	-
1.7.7.x.6	Low pressure alarm turns off outputs	0 [no]	1 [yes]	0 [no]	
1.7.7.x.7	Temperature alarm turns on outputs	0 [no]	1 [yes]	0 [no]	
1.7.7.x.8	Shutdown time after suction alarm	0	9999	5	sec.

1.7.7.x.1 Rotation outputs time:

Operation time of an output before entering rotation.

1.7.7.x.2 Transition time:

Time that the two outputs remain on during rotation.

1.7.7.x.3 Compressor start time:

Time between the activation of the pumps and the start of the first compressor of the corresponding suction. During the counting of this time the suction status is displayed as locked (Lock).

1.7.7.x.4 Digital output 1 address:

Digital output address for rotation.

20.PARAMETER TABLE

1.7.7.x.5 Digital output 2 address:

Digital output address for rotation.

1.7.7.x.6 Low pressure alarm turns off outputs:

It determines whether in case of low suction pressure alarm the pumps must be turned off or not.

1.7.7.x.7 Temperature alarm turns on outputs:

It determines whether in case of a low suction temperature alarm the pumps must be turned off or not.

1.7.7.x.8 Time for shutdown after suction alarm:

Time between the occurrence of a low pressure or temperature alarm to turn off the pumps.

1.7.8 Control status output:

Function	Description	Minimum	Maximum	Standard	Unit
1.7.8.1	Digital output address	0	-	0	-

1.7.8.1 Digital output address:

Digital output that indicates that the controller is operating.

1.7.9 Defrost for suction lines:

Function	Description	Minimum	Maximum	Standard	Unit
1.7.9.x.1	Condition for starting defrost	0	2	0	
1.7.9.x.2	Interval between defrost	1	9999	240	min
1.7.9.x.3	Number of defrost per day (Monday to Friday)	1	12	4	-
1.7.9.x.4	Time to start defrost (Monday to Friday)	00:00	23:59	06:00	hh:mm
1.7.9.x.5	Number of defrost per day (Saturday)	1	12	4	-
1.7.9.x.6	Time to start defrost (Saturday)	00:00	23:59	06:00	hh:mm
1.7.9.x.7	Number of defrost per day (Sunday)	1	12	4	-
1.7.9.x.8	Time to start defrost (Sunday)	00:00	23:59	06:00	hh:mm
1.7.9.x.9	Time defrost	1	999	30	min

1.7.9.x.1 Condition for starting defrost:

Determines the condition for starting defrost.

0 = Off. Does not perform defrost;
 1 = Manual defrost only;
 2 = Time;
 3 = Schedule.

1.7.9.x.2 Interval between defrosts:

Determines how often the defrost will be performed, with the time counting from the end of the previous defrost. Using when 1.7.9.x.1 = 1.

1.7.9.x.3 Number of defrost per day (Monday to Friday):

The defrost are distributed at equal intervals according to the schedule of the number of defrost per day, always considering the preferred time. This function is for programming from Monday to Friday. Allowed values are: 1, 2, 3, 4, 6, 8 or 12.

1.7.9.x.4 Time to start defrost:

A preferred (reference) time must be set so that one of the day's defrost takes place. This function is for programming from Monday to Friday.

1.7.9.x.5 and 1.7.9.x.6 Saturday:

A preferred (reference) time must be set so that one of the day's defrost takes place. This function is for Saturday programming.

1.7.9.x.7 and 1.7.9.x.8 Sunday:

A preferred (reference) time must be set so that one of the day's defrost takes place. This function is for Sunday programming.

1.7.9.x.9 Defrost time:

Time the suction line remains in defrost.

20.PARAMETER TABLE

1.8 Maintenance time:

Time setting for maintenance of compressors and fans.

1.8.x Suction/Discharge:

The letter x represents suctions (x between 1 and 3) and discharges (x between 4 and 6).

Function	Description	Minimum	Maximum	Standard	Unit
1.8.x.1	Maintenance time for compressor / fan 01	0 [off]	9999	0 [off]	h
1.8.x.2	Maintenance time for compressor / fan 02	0 [off]	9999	0 [off]	h
1.8.x.3	Maintenance time for compressor / fan 03	0 [off]	9999	0 [off]	h
1.8.x.4	Maintenance time for compressor / fan 04	0 [off]	9999	0 [off]	h
1.8.x.5	Maintenance time for compressor / fan 05	0 [off]	9999	0 [off]	h
1.8.x.6	Maintenance time for compressor / fan 06	0 [off]	9999	0 [off]	h

1.8.x.1 Time for compressor / fan maintenance 1 to 6:

Time for the alarm of hours worked of the compressor or fan.

1.9 Sensors:

Settings related to sensors.

1.9.x Sensors S1-S6:

The letter x represents the sensor inputs S1 to S6.

Function	Description	Minimum	Maximum	Standard	Unit
1.9.x.1	Pressure at 4mA	-14,7 (-1,0)	850,0 (58,6)	0	Psi (Bar)
1.9.x.2	Pressure at 20mA	-14,7 (-1,0)	850,0 (58,6)	500,0 (34,5)	Psi (Bar)
1.9.x.3	Pressure offset	-50,0 (-3,4)	50,0 (-3,4)	0	Psi (Bar)
1.9.x.4	Temperature offset	-50,0 (-90,0)	50,0 (90,0)	0 (0)	°C (°F)

1.9.x.1 Pressure at 4mA:

Sensor pressure value at 4mA (low full scale).

1.9.x.2 Pressure at 20mA:

Sensor pressure value at 20mA (high full scale).

1.9.x.3 Pressure offset:

It allows to offset deviations in the pressure reading.

1.9.x.4 Temperature offset:

It allows to offset deviations in the temperature reading.

1.10 Analog outputs:

Configuration of limit values for analog outputs.

1.10.x Analog outputs A1-A2:

The letter x represents the analog outputs A1 and A2.

Function	Description	Minimum	Maximum	Standard	Unit
1.10.x.1	Analog output actuation range	0	2	0	-
1.10.x.2	Minimum analog output value	0	100	0	%
1.10.x.3	Analog output starting value	0	100	0	%
1.10.x.4	Maximum analog output value	0	100	100	%

20.PARAMETER TABLE

1.10.x.1 Operating range of the analog output:

Defines the operating range of the output voltage. The minimum voltage value corresponds to 0% and the maximum value corresponds to 100% capacity of the linked compressor or fan.

0=0-10V

1=0-5V

2=1-5V

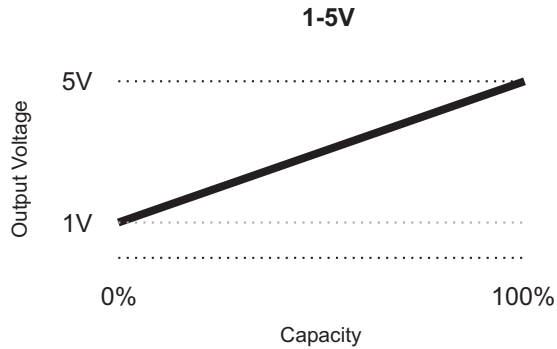
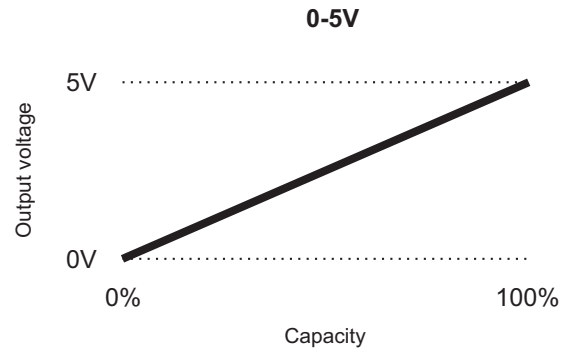
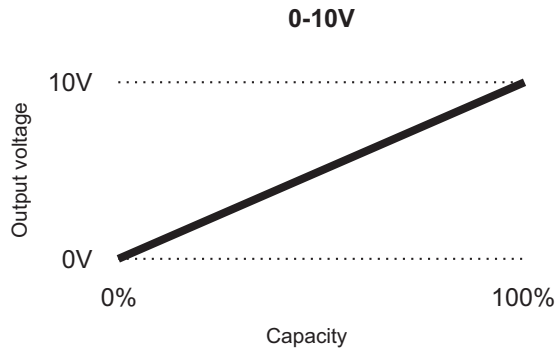

1.10.x.2 Minimum value of the analog output:

It is the minimum value that the analog output will take when it is actuated. This value is used to limit the minimum rotation speed of the compressor or fan.

1.10.x.3 Starting value of the analog output:

It is the value of the analog output during the start time.

1.10.x.4 Maximum value of the analog output

It is the maximum value that the analog output will take when it is actuated. This value is used to limit the maximum rotation speed of the compressor or fan.

1.11 Refrigerant curves: - Point 1 to point 20:

It allows to adjust a customized saturated refrigerant curve. If you want to use a refrigerant that is not included in the list, you can enter the saturation, pressure, and temperature values. The pressure and temperature values must be entered in ascending order from 1 to 20, that is, values from point 2 must be greater than the values of point 1. A minimum of 10 points must be configured for control. (Point 1 to point 10).

The letter "x" represents points 1 to 20.

Feature	Description	Minimum	Maximum	Standard	Unit
1.11.x.1	Point x - Pressure of the mapped curve	-14,8 [off] (-1,1)	850,0 (58,6)	-14,8 [off] (-1,1)	Psi (Bar)
1.11.x.2	Point x - Temperature of the mapped curve	-50,1 (-58,2)	200,0 (392,0)	-50,1 (-58,2)	°C (°F)

1.11.x.1 Point x - Pressure of the mapped curve:

Point pressure value.

1.11.x.2 Point x - Temperature of the mapped curve:

Point temperature value.

21. IMPORTANT

According to NBR 5410 standard chapters:

- 1: Install surge protectors in the supply
- 2: Sensor and serial communication cables can be assembled, but not in the same conduit through which power supply and charge actuation pass
- 3: Install transient suppressors (RC filter) in parallel to the charges, to increase the life span of relays.

Wiring schematics for suppressors in contactors

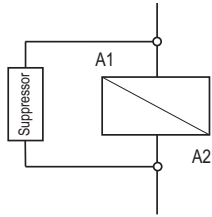

A1 and A2 are the contactor coil terminals

Wiring schematics for suppressors on charges with direct actuation

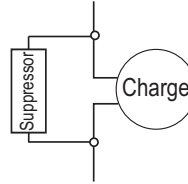

For light direct delivery maximum current Specified.

Full Gauge Controls makes suppressors available for sale

22. WARRANTY



ENVIRONMENTAL INFORMATION

Packing:

The materials used in the packaging of Full Gauge products are 100% recyclable. Try to dispose of it through specialized recycling agents.

Product:

The components used in Full Gauge controllers can be recycled and reused if disassembled by specialized companies.

Disposal:

Do not burn or dispose of controllers that reach the end of their life span in household trash. Observe the existing effective legislation in your region regarding the disposal of electronic waste. In case of any doubts, contact Full Gauge Controls.

WARRANTY TERM - FULL GAUGE CONTROLS

The products manufactured by Full Gauge Controls, from May 2005, have a warranty period of 10 (ten) years directly with the factory and 01 (one) year with accredited resellers/dealers, from the date of the consigned sale on the invoice. After this year with resellers, the warranty will continue to be effective if the instrument is sent directly to Full Gauge Controls. This period is valid for the Brazilian market. Other countries have a 2 (two) year warranty. The products are guaranteed in case of manufacturing failure that makes them improper or unsuitable for the applications for which they are intended. The warranty is limited to the maintenance of instruments manufactured by Full Gauge Controls, disregarding other types of expenses, such as indemnification due to damages caused to other equipment.

EXCEPTIONS TO WARRANTY

The Warranty does not cover transport and / or insurance costs for sending products with indications of defect or malfunction to Technical Assistance. The following events are also not covered: natural wear of parts, external damage caused by falls or improper packaging of products.

LOSS OF WARRANTY

The product will automatically lose its warranty if:

- The instructions for use and assembly in the technical description and the installation procedures present in Standard NBR5410 are not observed;
- It is subjected to conditions beyond the limits specified in its technical description;
- It is violated or repaired by a person who is not part of Full Gauge's technical team;
- The damage is caused by a fall, blow and / or impact, water infiltration, overload and / or atmospheric discharge.

WARRANTY USE

To be covered and benefit from the guarantee, the customer must send the product properly packed, together with the corresponding purchase invoice, to Full Gauge Controls. Shipping costs for products are at customer's costs. It is also necessary to send as much information as possible regarding the detected defect, thus making it possible to streamline the analysis, testing and service.

These processes and eventual product maintenance will only be carried out by Full Gauge Controls' Technical Assistance, at the Company's headquarters- Rua Júlio de Castilhos, 250, CEP 92120-030 - Canoas - Rio Grande do Sul - Brazil.