

## GAS-FIRED INFRARED PATIO HEATER INSTALLATION, OPERATION, AND MAINTENANCE

### MODEL RIHP



### ⚠ DANGER ⚠

#### FIRE OR EXPLOSION HAZARD

- Failure to follow safety warnings exactly could result in serious injury, death, or property damage.
- Improper installation, adjustment, alteration, service, or maintenance can cause serious injury, death, or property damage.
- Installation and service must be performed by a qualified installer, service agency, or the gas supplier.
- Be sure to read and understand the installation, operation, and service instructions in this manual.
- Do not store or use gasoline or other flammable vapors and liquids in the vicinity of this or any other appliance.

#### WHAT TO DO IF YOU SMELL GAS

- Do not try to light any appliance.
- Do not touch any electrical switch; do not use any phone in your building.
- Leave the building immediately.
- Immediately call your gas supplier from a phone remote from the building. Follow the gas supplier's instructions.
- If you cannot reach your gas supplier, call the fire department.

**DO NOT DESTROY. PLEASE READ CAREFULLY. KEEP IN A SAFE PLACE FOR FUTURE REFERENCE.**

# Table of Contents

<b>1.0)</b>	<b>SAFETY</b> .....	<b>3</b>
<b>2.0)</b>	<b>INSTALLER RESPONSIBILITY</b> .....	<b>3</b>
<b>3.0)</b>	<b>GENERAL INFORMATION</b> .....	<b>3</b>
<b>4.0)</b>	<b>MINIMUM CLEARANCES TO COMBUSTIBLES</b> .....	<b>6</b>
4.1)	<i>INDOOR CLEARANCES TO COMBUSTIBLES – RIHP35 MODELS</i> .....	8
4.2)	<i>OUTDOOR CLEARANCES TO COMBUSTIBLES – RIHP35 MODELS</i> .....	9
4.3)	<i>INDOOR CLEARANCES TO COMBUSTIBLES – RIHP50 MODELS</i> .....	10
4.4)	<i>OUTDOOR CLEARANCES TO COMBUSTIBLES – RIHP50 MODELS</i> .....	11
<b>5.0)</b>	<b>SPECIFICATIONS</b> .....	<b>12</b>
<b>6.0)</b>	<b>PACKING LIST</b> .....	<b>12</b>
<b>7.0)</b>	<b>HEATER SIZING GUIDELINES</b> .....	<b>13</b>
<b>8.0)</b>	<b>TYPICAL HEATER LAYOUTS</b> .....	<b>14</b>
<b>9.0)</b>	<b>DIMENSIONS</b> .....	<b>16</b>
<b>10.0)</b>	<b>ACCESSORIES</b> .....	<b>17</b>
<b>11.0)</b>	<b>UNPACKING THE HEATER</b> .....	<b>18</b>
<b>12.0)</b>	<b>INSTALLATION</b> .....	<b>19</b>
12.1)	<i>HEATER MOUNTING ANGLE</i> .....	20
12.2)	<i>INDOOR INSTALLATION – HANGING METHODS</i> .....	21
12.3)	<i>INDOOR / OUTDOOR RIGID HANGING BRACKETS</i> .....	21
<b>13.0)</b>	<b>HEAT SHIELD INSTALLATION</b> .....	<b>24</b>
<b>14.0)</b>	<b>ASSEMBLY OF THE CERAMIC GLASS</b> .....	<b>27</b>
<b>15.0)</b>	<b>GAS CONNECTIONS AND REGULATION</b> .....	<b>28</b>
15.1)	<i>INSTRUCTIONS FOR PRESSURE TEST GAUGE CONNECTION</i> .....	30
15.2)	<i>INLET GAS PRESSURE CHECK</i> .....	30
15.3)	<i>OUTLET GAS PRESSURE CHECK AND ADJUSTMENTS</i> .....	30
<b>16.0)</b>	<b>ELECTRICAL CONNECTIONS</b> .....	<b>31</b>
16.1)	<i>INTERNAL CONNECTION WIRING DIAGRAM –STANDARD MODELS</i> .....	32
16.2)	<i>FIELD CONNECTIONS AND WIRING DIAGRAMS – 2 STAGE 24V – MODELS WITHOUT REMOTE</i> .....	33
16.3)	<i>FIELD CONNECTIONS AND WIRING DIAGRAMS – SINGLE STAGE 24V – MODELS WITHOUT REMOTE</i> .....	35
16.4)	<i>FIELD CONNECTIONS AND WIRING DIAGRAMS – SINGLE STAGE 120V MODELS WITHOUT REMOTE</i> .....	36
16.5)	<i>INTERNAL CONNECTION WIRING DIAGRAM – MODELS WITH REMOTE</i> .....	37
16.6)	<i>FIELD CONNECTION AND WIRING DIAGRAM – 2 STAGE 24V MODELS WITH REMOTE</i> .....	38
<b>17.0)</b>	<b>VENTILATION</b> .....	<b>39</b>
<b>18.0)</b>	<b>LIGHTING AND SHUTDOWN INSTRUCTIONS</b> .....	<b>40</b>
18.1)	<i>HEATER OPERATION – MODELS WITH REMOTE</i> .....	40
18.2)	<i>SEQUENCE OF OPERATION</i> .....	42
<b>19.0)</b>	<b>SERVICING AND ANNUAL MAINTENANCE</b> .....	<b>43</b>
<b>20.0)</b>	<b>TROUBLE SHOOTING</b> .....	<b>44</b>
20.1)	<i>TROUBLE SHOOTING – MODELS WITHOUT REMOTE</i> .....	45
20.2)	<i>TROUBLE SHOOTING – MODELS WITH REMOTE</i> .....	46

**LIMITED WARRANTY:** Reznor, the manufacturer, warrants to the original owner of any REZNOR infrared gas heater that said heater will be free from defects in material or workmanship under normal use and service. The heater(s) shall be installed, used, and maintained strictly in accordance with the manufacturer's instructions. The manufacturer's sole obligation under this warranty shall be limited to furnishing replacement parts, F.O.B. , for 12 months from the date of installation, or 18 months from the date of shipment by the manufacturer, whichever period shall expire first. Labor charges for removal of defective parts and the installation of the replacement parts are not included. This warranty applies only within the USA and Canada.

**WARNING:** Manufacturer's warranty shall not apply: (a) to damage to the heater when used in an atmosphere containing halogenated hydrocarbons or other corrosive chemicals. Some compounds in the air can be ingested into the equipment and can cause an accelerated rate of corrosion of some of the parts of the heating components. The use of such chemical compounds in or near the operating environment of the heater should be avoided where a longer heater life is desirable; (b) to any heater or components which have been repaired or replaced with other than factory parts, modified in any way, misused, or damaged, or which have been used contrary to the manufacturer's written instructions. Replacement parts are available through Reznor representatives or their distributors.

**LIMITATION OF WARRANTY:** THERE ARE NO WARRANTIES, EXPRESS OR IMPLIED, WHICH EXTEND BEYOND THE DESCRIPTION ON THE FACE HEREOF. WITHOUT LIMITING THE FOREGOING, THE MANUFACTURER EXPRESSLY EXCLUDES ANY AND ALL IMPLIED WARRANTIES, INCLUDING BUT NOT LIMITED TO ANY IMPLIED WARRANTY OF FITNESS FOR A PARTICULAR PURPOSE AND ANY IMPLIED WARRANTY OF MERCHANTABILITY FOR ITS PRODUCTS.

If any provision of this warranty is found to be void, unenforceable or unconscionable, then the same is hereby severed and the remainder of this warranty is hereby saved and shall remain in force.

**EXCLUSIVE REMEDY:** The sole and exclusive remedy under this warranty is the replacement of the defective parts or heaters as hereinabove specified. THE MANUFACTURER DOES HEREBY EXPRESSLY EXCLUDE ANY AND ALL LIABILITY FOR INCIDENTAL AND CONSEQUENTIAL DAMAGES UNDER THIS OR ANY OTHER WARRANTY. Without intending to limit the aforesaid exclusion, THE MANUFACTURER DOES HEREBY EXCLUDE ANY LIABILITY UNDER THIS OR ANY OTHER WARRANTY FOR INJURIES AND COMMERCIAL LOSSES TO PROPERTY THAT RESULT FROM THE OPERATION, PROPER OR IMPROPER, OF ITS PRODUCTS.

**ADDITIONAL WARRANTY ON BURNER ASSEMBLY:** Manufacturer warrants to the original owner of any CSA design certified heater that, if installed, used and maintained strictly in accordance with the printed instructions received with the heater, the manufacturer will at any time during the below listed time periods, furnish at no cost to the original owner, replacement burners which have become inoperative by reason of any defect in our workmanship, materials or construction. The manufacturer's obligation under this warranty shall be limited to furnishing replacements for three years from the date of installation:

The manufacturer will not be responsible for labor charges incurred for removal or installation of burners. Any transportation charges involved in the return or repair are excluded.

**ADDITIONAL TERMS:** Manufacturer assumes no liability for delay in performing its obligations under the aforesaid warranty. Manufacturer assumes no liability for failure in performing its obligations there under if failure results directly or indirectly from any cause beyond its control, including but not limited to acts of God, acts of Government, floods, fires, shortages of materials, strikes and other labor difficulties or delays or failures of transportation facilities.

**THIS FOR ALL OUTDOOR APPLICATIONS AND INDUSTRIAL/COMMERCIAL NON-RESIDENTIAL APPLICATIONS.** Installation and service shall be by a Licensed Contractor and in accordance with National and Local Codes.

When presenting warranty claims, proof of date of purchase must be submitted.  
No Representative is authorized to assume for the manufacturer any liability except as set forth above.

In case of claim under this warranty, contact:

## 1.0) SAFETY

This heater is a self-contained infrared radiant ceramic heater. Safety information required during installation and operation of this heater is provided in this manual and the labels on the product. The installation, service and maintenance of this heater must be performed by a contractor qualified in the installation and service of gas fired heating equipment.

All personnel in contact with the heater must read and understand all safety information, instructions, and labels before operation. The following symbols will be used in this manual to indicate important safety information.

### **WARNING**

**Warning** instructions must be followed to prevent or avoid hazards which may cause death, serious injury, or property damage.

### **CAUTION**

**Caution** instructions must be followed to prevent incorrect operation or installation of the heater which may cause minor injury or property damage.

## 2.0) INSTALLER RESPONSIBILITY

The installer is responsible for the following:

- The heater installation, electrical and gas supplies must be installed in accordance with these installation instructions and any applicable codes and regulations.
- Every heater shall be located with respect to building construction and other equipment to permit access to the heater.
- Each installer must follow the clearances to combustible materials for the heaters.
- It is important to read and understand section 4.0) where outdoor spaces are defined any space other than outdoors is an indoor installation.
- Install the heater so that the supports and hangers are correctly spaced in accordance with these instructions. The heater must be supported by materials having a working load limit of at least 115 lbs.
- To install the heater in an adequate free area to allow the products of combustion to freely escape from the heater. The heater must not be installed in recessed spaces or enclosures and alcoves.
- Supply the owner with a copy of these Installation and Operation Instructions.
- If the heater is installed indoors, ventilation by gravity or mechanical means shall be provided to supply at least 4 CFM of exhaust air per 1,000 Btu/hr of operating heat input.
- Never use the heater as a support for a ladder or other access equipment. Do not hang anything from the heater.
- Supply all installation materials necessary that are not included with the heater.
- Check the nameplate to make sure that the burner is correct for the gas type in the building.
- Use the provided angle gauge (see Section 12.1) to ensure the heater is installed at the approved installation angles of 0°, 15°, 30°, 45° and 60° with the heat shield installed.

## 3.0) GENERAL INFORMATION

This heater is a self-contained infrared radiant ceramic patio heater for use in locations where flammable gases or vapors are not generally present and is intended for space heating **non-residential spaces**.

This patio heater model is approved to two different heater standards:

- A **“Patio Heater”** for **Outdoor Use** in Residential and Commercial/Industrial Applications.
- And as a **“Gas-Fired High Intensity Infrared Heater”** for **Indoor Spaces** of Commercial/ Industrial Applications. Not for use in residential dwellings.

**Note:** A residential dwelling is a domicile intended for use by one or more persons and that includes one or more areas, such as those used for cooking, eating, living, sleeping, or a sanitary facility. A residential dwelling does not include a workshop, or outdoors.

<b>⚠ WARNING</b>	
	
<b>Carbon Monoxide and Fire Hazard</b>	
<p>This heater is not approved to be installed in any residential indoor application. This includes, but is not limited to, the home, living quarters, attached garages, solariums, RV's, mobile homes, etc.</p> <p>Installation in residential indoor spaces may result in death, asphyxiation, serious injury or property damage.</p>	

<b>⚠ WARNING</b>

<b>Fire Hazard</b>
<p>Keep all flammable objects, liquids and vapors the minimum required clearances to combustibles away from equipment.</p> <p>Some objects will catch fire or explode when placed close to equipment.</p> <p>Failure to follow these instructions can result in death, injury or property damage.</p>

### SAFETY REQUIREMENTS

- The heater area must be kept clear and free from combustible materials, gasoline and other flammable vapors and liquids.
- This heater is designed for use with one type of gas (Propane or Natural). Make sure that the type of gas to be supplied to this heater matches that shown on the heater rating plate.
- DO NOT install this heater directly onto a propane container or propane cylinder. Propane containers (propane cylinders) must not be stored indoors or in the vicinity of any gas-burning appliance.
- DO NOT Store flammable materials near the heater.
- DO NOT locate gas and electric supply lines directly above the heaters path of flue products. The path of flue products will change if an optional low clearance heat shield is installed.
- Children and adults should be alerted to the hazards of high surface temperatures and should stay away to avoid burns or clothing ignition.
- Young Children should be carefully supervised when they are around the heater.
- DO NOT spray aerosols or flammable materials in the vicinity of this appliance while it is in operation.
- Clothing or other flammable materials should not be hung from the heater or placed on or near the heater.
- NEVER attempt to service the heater while it is plugged in, operating or hot.
- Any guard or other protective device removed for servicing a heater must be replaced prior to operating the heater.
- DO NOT Install the heater in a recess, alcove, or enclosure.
- Installation and repair should be done by a licensed contractor qualified in the installation and service of gas heating equipment. The heater should be inspected before use and at least annually by a qualified service person. More frequent cleaning may be required as necessary. It is imperative that the control compartment, air passageways and burner of the heater be kept clean.
- If any changes are made to the patio or building structure after the heaters are installed such as adding plastic curtains to enclose the patio the modified design must be checked by a qualified person to ensure that the clearance combustibles and ventilation requirements are maintained.
- DO NOT paint any surface of the heater.
- DO NOT throw objects at the heater.
- Avoid inhaling fumes emitted from the heater's first use. Smoke and odor from the burning of oils used in manufacturing will appear. Both the smoke and odor will dissipate after approximately 30 minutes.

### INSTALLATION REQUIREMENTS

Installation of this heater must conform with local building codes or, in the absence of local codes, with the National Fuel Gas Code, ANSI Z223.1/NFPA 54, or the Natural Gas and Propane Installation Code, CSA B149.1 In Canada, the installation must conform to current CSA B149.1 (The Natural Gas and Propane Installation Code) in the absence of local codes. Heaters shall be installed by a licensed contractor or licensed installer. **Clearances to combustibles as outlined in this manual should always be observed. In areas used for storage of combustible materials where they may be stacked below the heater, NFPA54 requires that the installer must post signs that will "specify the maximum permissible stacking height to maintain the required clearances from the heater to combustibles."**

Every heater shall be located with respect to building construction and other equipment to permit access to the heater. Each installer shall use quality installation practices when locating the heater and must consider clearances to combustible materials, vehicles parked below, lights, overhead doors, storage areas with stacked materials, sprinkler heads, gas and electrical lines, and any other possible obstructions or hazards. Consideration must also be given to service accessibility.

Reznor will not recognize the warranty for any use other than space heating. This heater is for Indoor and Outdoor Installation and is used in Unvented mode. The term Unvented means Indirect Vented. While the products of combustion are expelled into the building, national codes require 4 CFM/1000 BTU of heater input ventilation in the building to dilute these products of combustion. This ventilation may be provided by gravity or mechanical means.

This heater is not an explosion proof heater. Where the possibility of exposure to volatile and low flash point materials exists, it could result in property damage or death. This heater must not be installed in a spray booth where the heater can operate during the spraying process. Consult your local fire marshal or insurance company.

This heater must be applied and operated under the general concepts of reasonable use and installed using the best building practices.

It is the responsibility of the qualified installer to supply the appropriate lifting equipment to safely install the radiant heater. Tools required for the safe installation, startup and maintenance are various screwdrivers, wrenches, pipe wrenches, voltmeter, air and gas manometer, level and required tools to safely install the chosen hanging materials.

 **CAUTION** Do not install this heater indoors in a structure with no insulation in the roof—condensation will occur.

The heater, when installed in aircraft hangars and public garages, must be installed in accordance with ANSI/NFPA 409-latest edition (Standard for Aircraft Hangars), ANSI/NFPA 88a-latest edition (Standard for Parking Structures), and ANSI/NFPA 88b-latest edition (Standard for Repair Garages) with the following clearances:

- a. At least 10 feet above the upper surfaces of wings or engine enclosures of the highest aircraft that may be housed in the hangar and at least 8 feet above the floor in shops, offices, and other sections of hangars communicating with aircraft storage or service areas.
- b. At least 8 feet above the floor in public garages. **▲ WARNING:** Minimum clearances marked on the heater must be maintained from vehicles parked below the heater.

**(FOR CANADA ONLY)**

- a. The installation of this appliance is to be in accordance with the latest edition of CSA B149.1 (Natural Gas and Propane Installation Code).
- b. For installation in public garages or aircraft hangars, the minimum clearances from the bottom of the infrared heater to the upper surface of the highest aircraft or vehicle shall be 50 percent greater than the certified minimum clearance, but the clearance shall not be less than 8 feet.

## 4.0) MINIMUM CLEARANCES TO COMBUSTIBLES



A critical safety factor to consider before installation is the clearances to combustible materials. Clearance to combustibles is defined as the minimum distance you must have between the surfaces of the heater and the combustible item. Considerations must also be made for moving objects around the infrared heater.

**WARNING** This heater must not be installed where the products of combustion can build up and prevent them being exhausted to the atmosphere. This includes applications such as enclosures, recessed ceilings, and alcoves.

**WARNING** This heater can be equipped with a heat shield to reduce the clearances to combustibles towards the ceiling. Due to the variety of possible heater mounting angles the heat shield must be mounted in the correct location to match the heater mounting angle. See section 13.0 heat shield installation.

Approved installation angles are 0°, 15°, 30°, 45° and 60° with the heat shield installed.

**WARNING** Certain materials or objects, when stored under the heater, will be subjected to radiant heat and could be seriously damaged. Observe the Minimum Clearances to Combustibles always listed in the manual and on the heater.

For maximum safety the building must be evaluated for hazards before installing the heater system.

Examples include, but are not limited to:

- Gas and electrical lines
- Combustible and explosive materials
- Chemical storage areas
- Areas of high chemical fume concentrations
- Provisions for accessibility to the heater
- Adequate clearances around the openings
- Combustion and ventilating air supply
- Vehicles parking areas
- Vehicles with lifts or cranes
- Storage areas with stacked materials
- Lights
- Sprinkler heads
- Overhead doors and tracks
- Dirty, contaminated environment

This heater is approved for both **INDOOR** and **OUTDOOR** installation. Both installation options have different clearances to combustibles as described below. These must be observed.

**INDOOR** clearances to combustibles are defined as a surface temperature of **90°F** above ambient temperature.

**OUTDOOR** clearances to combustibles are defined as a surface temperature of **117°F** above ambient temperature.

**OUTDOOR** Spaces are defined as a shelter no more inclusive than:

- a) with walls on all sides, but with no overhead cover.
- b) within a partial enclosure which includes an overhead cover and no more than two side walls. These side walls may be parallel, as in a breezeway, or at right angles to each other.
- c) Within a partial enclosure which includes an overhead cover and three side walls, if 30 percent or more of the horizontal periphery of the enclosure is permanently open.

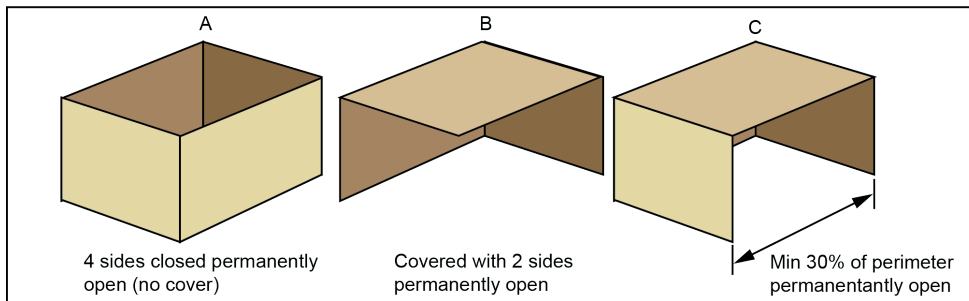

**⚠ WARNING** For the purposes of clearances to combustibles and ventilation all applications not classified as outdoors according to the definitions above shall comply with the requirements for indoor installations.

Minimum clearances shall be measured from the outer surfaces of the heater or heat shield if installed, as shown in the diagrams for the different installation positions.

**⚠ WARNING** Fire sprinkler heads must be located at an appropriate distance from the heater. This distance may exceed the published clearance to combustibles. The exhaust gas temperature will be 800 °F (426 °C) and above where it exits the heater. Certain applications will require the use of high temperature sprinkler heads or relocation of the heaters. Sprinkler head temperatures lower than “blue color code” might not be suitable in the vicinity of the heater.

Sprinkler systems containing propylene glycol or other flammable substances are not to be used in conjunction with this heater without careful consideration for and avoidance of potential fire or explosion hazards. For further information consult the authority having jurisdiction. Always observe applicable state and local codes.

**⚠ WARNING** Always maintain minimum clearances and post signs where needed. This heater is supplied with a wall mounted sign shown below. It is the installers responsibility to ensure that the sign is completed with the correct clearance to combustible distances for the installation and that the sign is posted in a location where it is easily accessed.

**⚠ WARNING**

## FIRE HAZARD

Combustible material must be located outside the clearance distance listed from heater. Some objects will catch fire or explode when placed close to heater. Failure to follow to do so may result in death, injury or property damage.

**Maintain the following clearances: \_\_\_\_\_ to the side, \_\_\_\_\_ above and 40” below the heater from combustible materials.**

ATTACH THIS INFORMATION CARD ADJACENT TO THE GORDONGLO ELITE HEATER(S) CONTROLS(S)

- INSTALLER: Write the highest clearance distance any model in the blank spaces above using permanent ink. The clearances to combustibles can be located on a label attached to the heater or in the I & O Instructions. I & O's can also be located on [www.robertsgordon.com](http://www.robertsgordon.com) Phone 716-852-4400
- Enclosing a patio with a wind break etc. may change the heater location from being OUTDOOR to INDOOR. See I & O instructions for INDOOR clearances to combustible and ventilation requirements.
- Read the Installation and Operating Instructions (I & Os) thoroughly before installation, operation or service.

Installation and Service of GordonGlo Elite equipment must be performed by a qualified contractor and conform with all requirements of I & O Instructions, National and Local codes. Annual inspection is recommended prior to the heating season to ensure proper operation of the heating equipment.

PN 43344950 NOV 2018

**⚠ WARNING** Clearances to combustibles are posted on the heater. In areas used for storage of combustible materials where they may be stacked below the heater the installer must post signs that will “specify the maximum permissible stacking height to maintain the required clearances from the heater to combustibles.” Reznor recommends posting these signs adjacent to the heater thermostat or other suitable location that will provide enhanced visibility

## 4.1) INDOOR CLEARANCES TO COMBUSTIBLES – RIHP35 MODELS

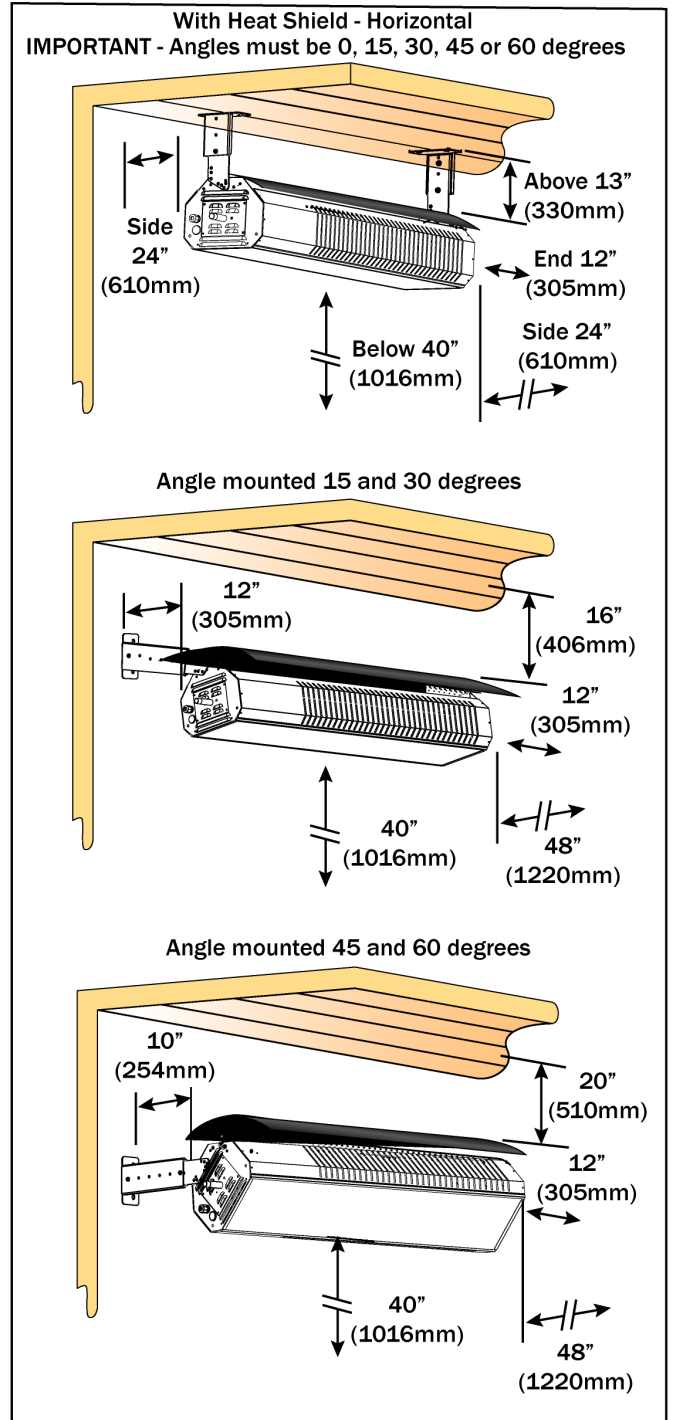
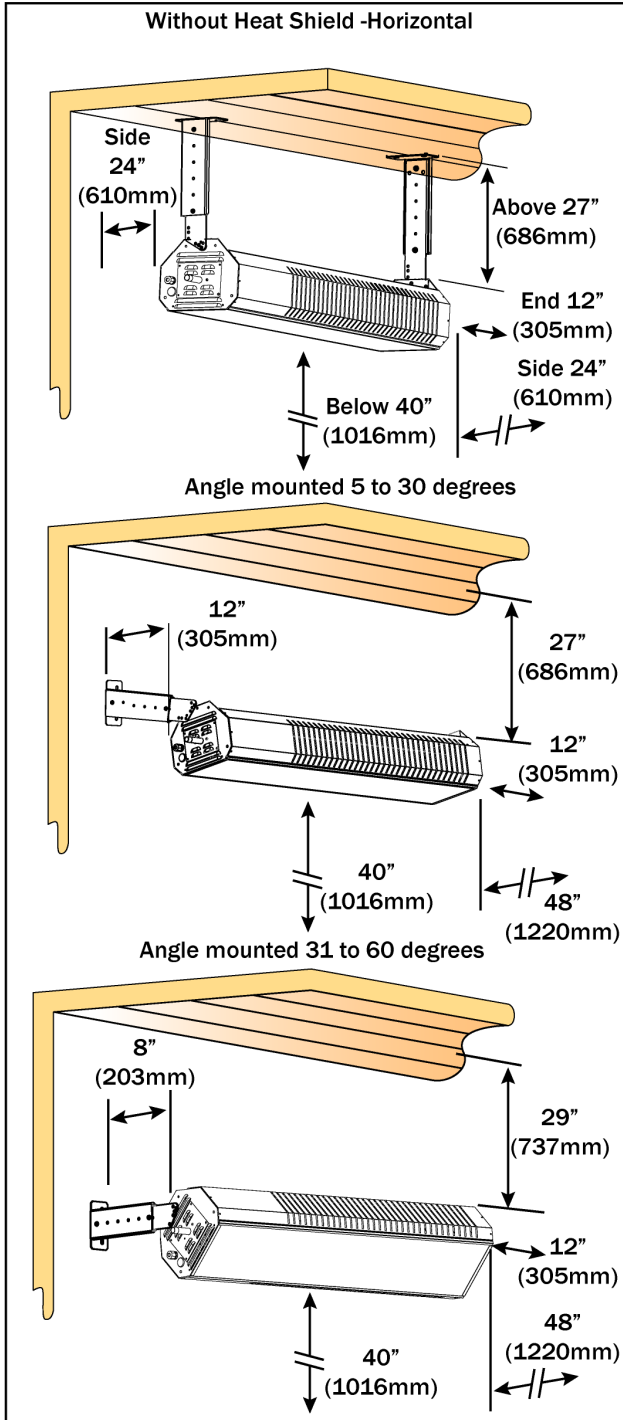

### ⚠ WARNING

The stated clearance to combustibles represents a surface temperature of 90° F (50° C) above room temperature. Building materials with a low heat tolerance (such as plastics, vinyl siding, canvas, tri-ply, etc.) may be subject to degradation at lower temperatures. It is the installer's responsibility to assure that adjacent materials are protected from degradation.

See below the possible surface temperature at the clearance to combustible distance for different ambient temperatures within the heated space.

Ambient Temperature	70° F (21.1° C)	65° F (18.3° C)	60° F (15.5° C)
Surface Temperature	160° F (71.1° C)	155° F (68.3° C)	150° F (65.6° C)

## 4.2) OUTDOOR CLEARANCES TO COMBUSTIBLES – RIHP35 MODELS

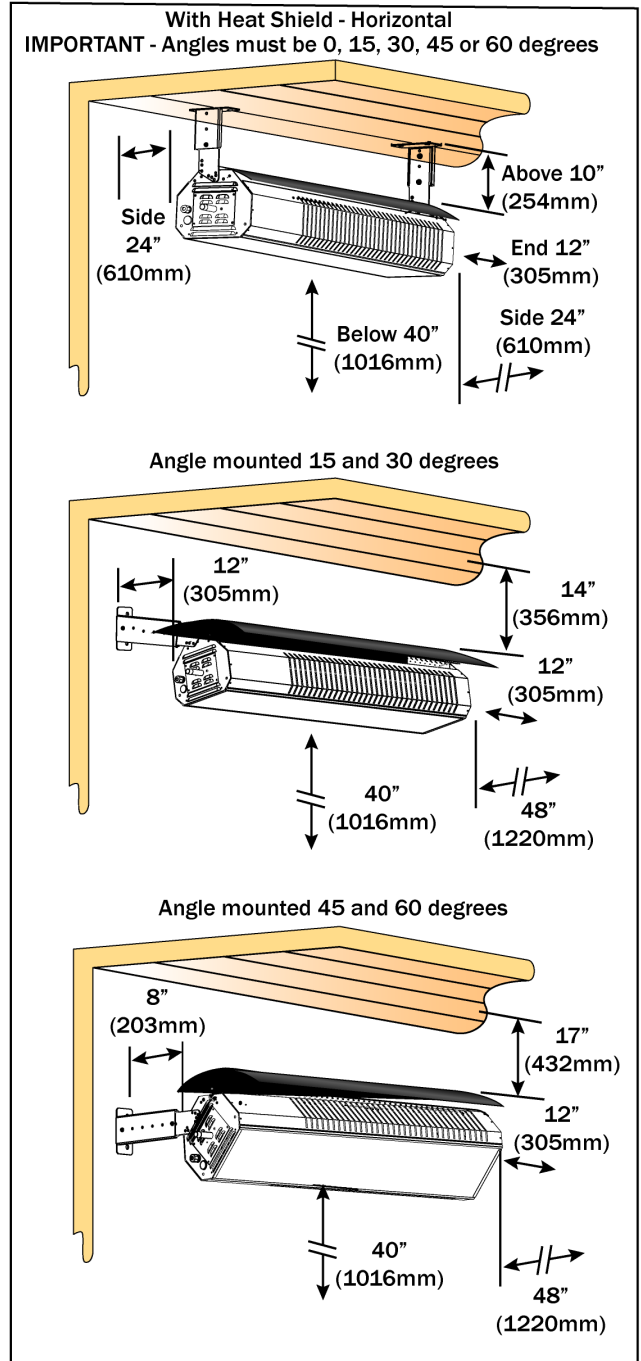
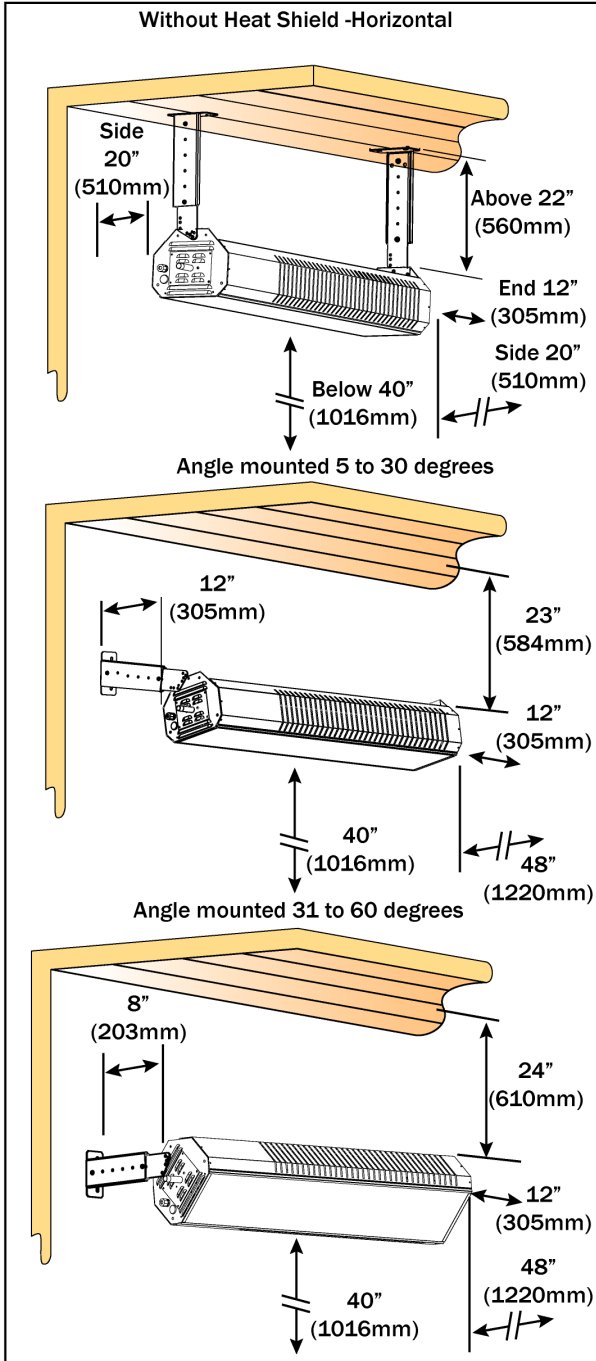

**⚠ WARNING** The stated clearance to combustibles represents a surface temperature of 117° F (65° C) above room temperature. Building materials with a low heat tolerance (such as plastics, vinyl siding, canvas, tri-ply, etc.) may be subject to degradation at lower temperatures. It is the installer's responsibility to assure that adjacent materials are protected from degradation.

See below the possible surface temperature at the clearance to combustible distance for different ambient temperatures within the heated space.

Ambient Temperature	70° F (21.1° C)	65° F (18.3° C)	60° F (15.5° C)
Surface Temperature	187° F (86.1° C)	182° F (83.3° C)	177° F (80.6° C)

### 4.3) INDOOR CLEARANCES TO COMBUSTIBLES – RIHP50 MODELS

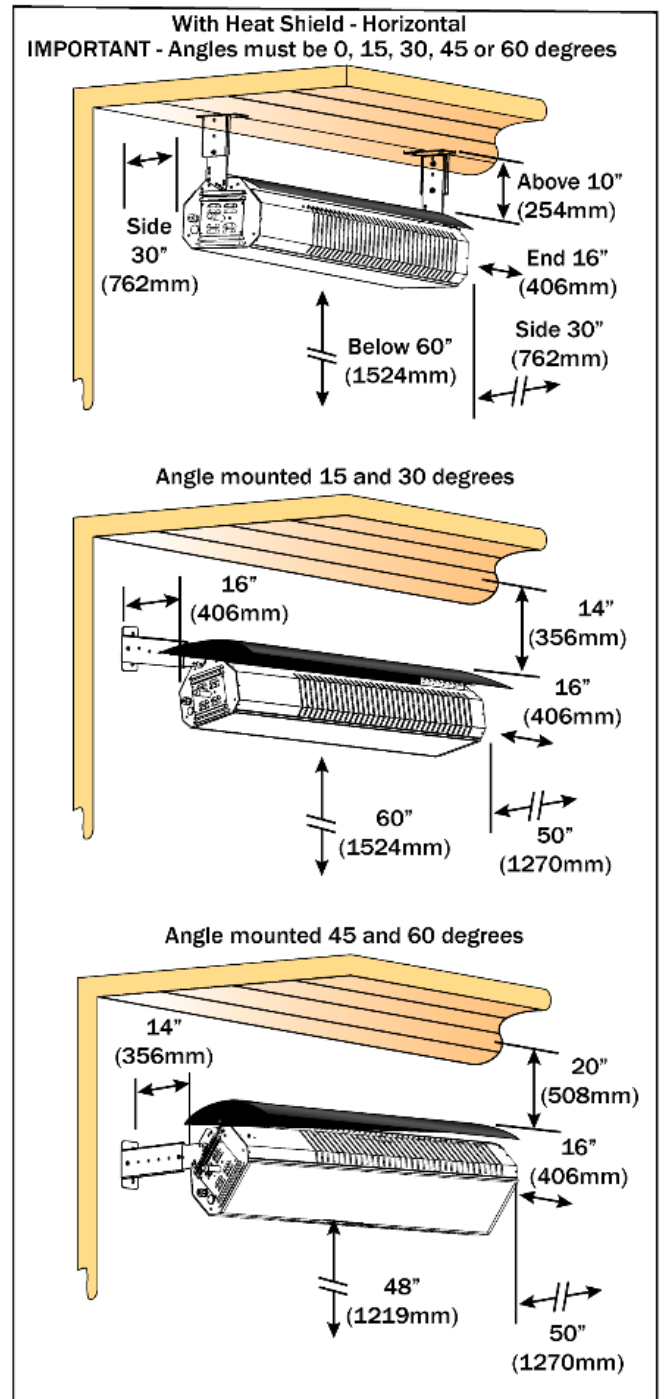
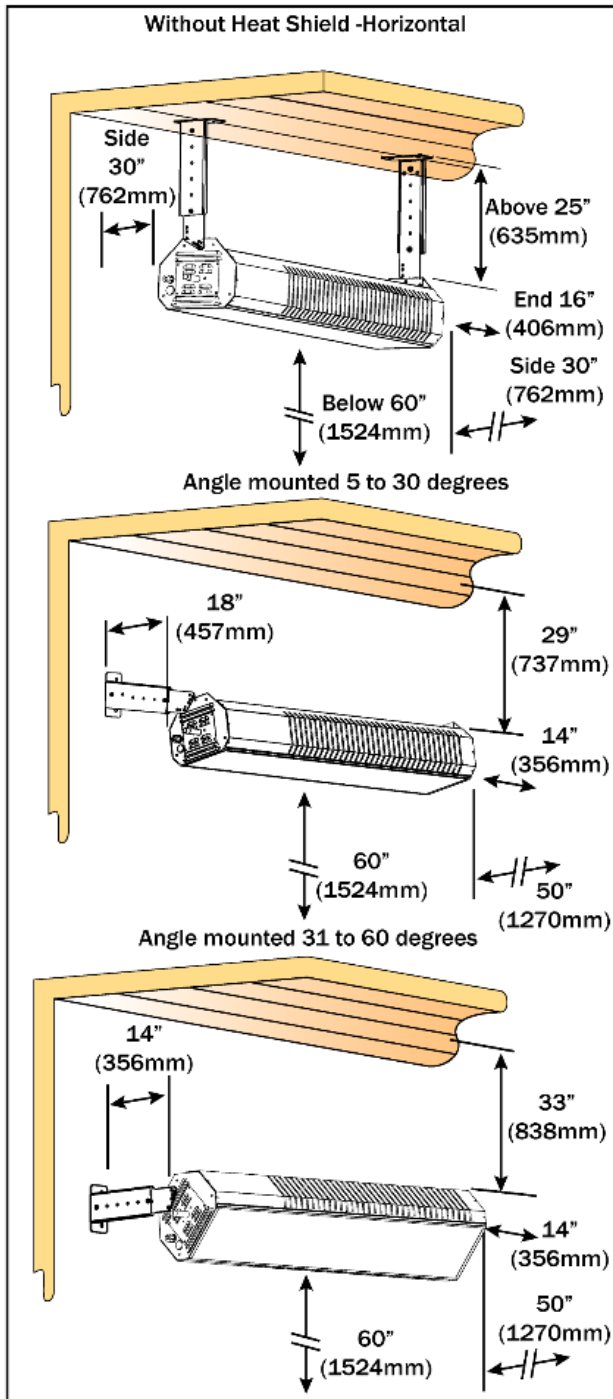

**⚠ WARNING** The stated clearance to combustibles represents a surface temperature of 90° F (50° C) above room temperature. Building materials with a low heat tolerance (such as plastics, vinyl siding, canvas, tri-ply, etc.) may be subject to degradation at lower temperatures. It is the installer's responsibility to assure that adjacent materials are protected from degradation.

See below the possible surface temperature at the clearance to combustible distance for different ambient temperatures within the heated space.

Ambient Temperature	70° F (21.1° C)	65° F (18.3° C)	60° F (15.5° C)
Surface Temperature	160° F (71.1° C)	155° F (68.3° C)	150° F (65.6° C)

## 4.4) OUTDOOR CLEARANCES TO COMBUSTIBLES – RIHP50 MODELS

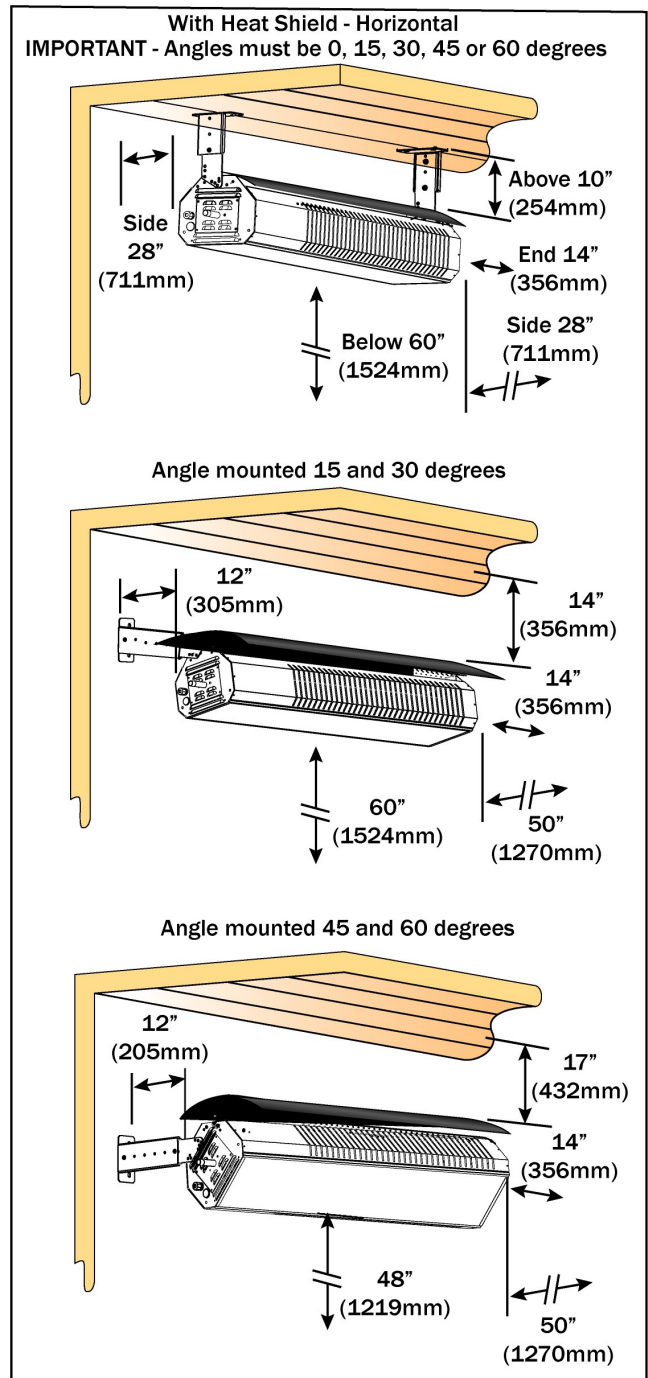
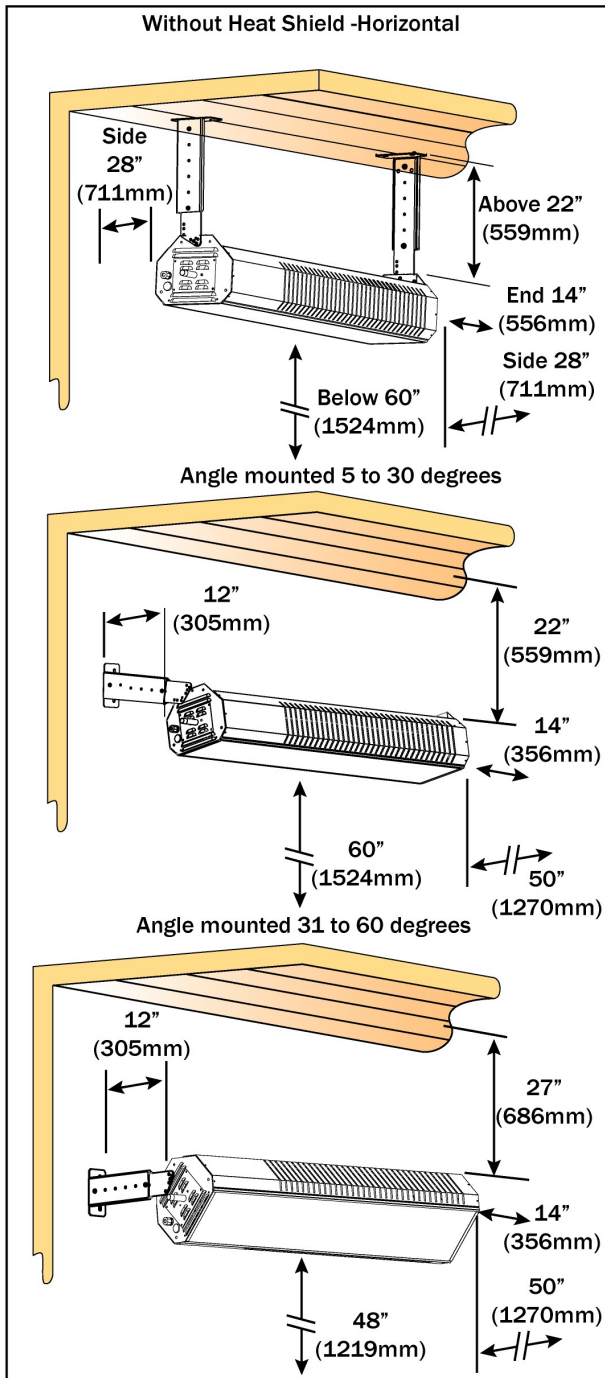

**⚠ WARNING** The stated clearance to combustibles represents a surface temperature of 117° F (65° C) above room temperature. Building materials with a low heat tolerance (such as plastics, vinyl siding, canvas, tri-ply, etc.) may be subject to degradation at lower temperatures. It is the installer's responsibility to assure that adjacent materials are protected from degradation.

See below the possible surface temperature at the clearance to combustible distance for different ambient temperatures within the heated space.

Ambient Temperature	70° F (21.1° C)	65° F (18.3° C)	60° F (15.5° C)
Surface Temperature	187° F (86.1° C)	182° F (83.3° C)	177° F (80.6° C)

## 5.0) SPECIFICATIONS

Model No.	Btu/hr High Input	(2-stage) Btu/hr Low Input	Orifice Size				Recommended* Mounting Height		
			Natural Gas		Propane Gas		@ 0 °	@ 5 ° to 30 °	@ 30° to 60 °
RIHP35 series	35,000	24,000	#41	0.096 inch	#51	0.067 inch	8 to 11 ft	7 to 9 ft	6.5 to 8 ft
RIHP50 series	50,000	34,000	2.9mm	0.114 inch	1.95 mm	0.077 inch	9 to 12 ft	8.5 to 11 ft	8 to 10 ft

\* For mounting heights outside the recommended distances consult your local Reznor Representative.

### Model Identification:

Control Option Suffix	Gas Type	Description
NG	Natural	Two Stage White-Rodgers 36J Gas Valve - High/Low Fire
LG	Propane	Two Stage White-Rodgers 36J Gas Valve - High/Low Fire
NG-RM	Natural	Two Stage White-Rodgers 36J Gas Valve - High/Low Fire (with remote)
LP-RM	Propane	Two Stage White-Rodgers 36J Gas Valve - High/Low Fire (with remote)

Two stage heaters are supplied with a jumper to enable single stage (high fire only) operation. See electrical section 16.0 for instructions.

Type Gas	Gas Pipe Connection	Electrical Supply	Current Rating	Weight
Natural or Propane	½" NPT (Male)	120 Volt, 60Hz, 1 Phase	0.4 Amp	RIHP35 - 55 lbs. RIHP50 - 62 lbs.

Module Electrical Rating:	Ignition System (direct spark):
Input-Control: 18-30 VAC 50/60 Hz (class 2 transformer) Input Powerline: 120 VAC (L1, IND contacts only) Flame Sensitivity: 0.7 µA (microamps) minimum	10 second trial for ignition period 7 second pre-purge period 15 second inter-purge period 3 tries for ignition separate flame sensor potted, 100% water protected

Approved installation angles are 0, 15, 30, 45 and 60 degrees with heat shield installed.

## 6.0) PACKING LIST

Package contents are listed below:

Model	Part Number	Gas Type
RIHP35 - 2 STAGE	RIHP0001001	Natural
RIHP35 - 2 STAGE	RIHP0001002	Propane
RIHP35-RM - 2 STAGE - (with remote)	RIHP0001003	Natural
RIHP35-RM - 2 STAGE - (with remote)	RIHP0001004	Propane
RIHP50 - 2 STAGE	RIHP0001005	Natural
RIHP50- 2 STAGE	RIHP0001006	Propane
RIHP50-RM - 2 STAGE - (with remote)	RIHP0001007	Natural
RIHP50-RM - 2 STAGE - (with remote)	RIHP0001008	Propane

Number	Part Number	Description	Qty Per
1	See Above	Patio Heater	1
2	41373050	Ceramic Glass 8.94" x 48" Black (RIHP35)	1
2a	41375070	Ceramic Glass 10.50" x 48" Black (RIHP50)	1
3	43344950	Reznor Clearances Sign	1
4	44568039	Angle Mounting Gauge Plate	1
5	30809990	Remote 2-stage Reznor (W/REMOTE models only)	1
7	1047557R	3 Position Switch Kit (W/REMOTE models only)	1

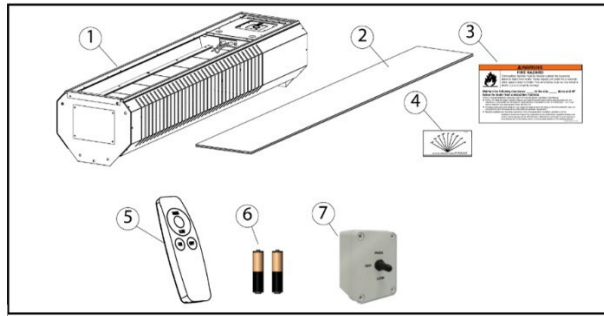

## 7.0) HEATER SIZING GUIDELINES

Radiant heaters work like the sun to emit radiant heat directly to the space to increase the comfort of the patio guests. Suitable applications include patios, porches, outdoor shopping areas and pathways.

The amount of temperature increase in outdoor patio spaces will be dependent on the following factors:

1. The number of heaters in the space is important to provide good coverage of the area to be heated.
2. Take care not to mount the heaters too low or too close together this can make people directly below the heaters uncomfortable.
3. It is recommended to use a suitable windbreak to reduce the effects of direct wind on the patio. If an area is going to be unprotected and is a breezy location, then heaters may need to be located closer together. Wind breaks must be designed to allow fresh air for ventilation.
4. Angling the heaters greater than 30 degrees should be avoided unless the mounting height is low, when the heaters are angled more than 30 degrees the radiant intensity is lower and will reduce the amount of heat felt by the guests.

**⚠ CAUTION** When angle mounting the heater, the radiant output will decrease approximately by following:

Mounting Angle	15°	30°	45°	60°
Radiant output reduction	3%	13%	29%	50%

5. It is recommended to place the heaters around greatest heat loss facing into the patio area.

The tables below show minimum area coverage per heater for outdoor patio heating based on a 5 to 10° F (2.8 to 5.6° C) temperature rise.

### Models RIHP35:

Mounting Angle	Mounting Height	Breezy Exposed Location	Moderately Protected	Well Protected
Horizontal	8ft. - 11ft. (2.4 - 3.4m)	8 x 8 ft (2.4 x 2.4m)	10 x 10 ft. (3.0 x 3.0m)	12 x 12 ft. (3.7 x 3.7m)
Up to 30° Angled	7ft. - 9ft. (2.1 - 2.7m)	8 x 8 ft (2.4 x 2.4m)	9 x 9 ft. (2.7 x 2.7m)	11 x 11 ft. (3.4 x 3.4m)
30 to 60° Angled	6.5ft. - 8ft. (1.9 - 2.4m)	Not Recommended		8 x 8 ft. (2.4 x 2.4m)

### Models RIHP50:

Mounting Angle	Mounting Height	Breezy Exposed Location	Moderately Protected	Well Protected
Horizontal	9ft. - 12ft. (2.7 - 3.7m)	8 x 10 ft (2.4 x 3.0m)	10 x 12 ft. (3.0 x 3.7m)	12 x 14 ft. (3.7 x 4.3m)
Up to 30° Angled	8.5ft. - 11ft. (2.6 - 3.4m)	8 x 9 ft (2.4 x 2.7m)	9 x 11 ft. (2.7 x 3.4m)	11 x 13ft. (3.4 x 4.0m)
30 to 60° Angled	8ft. - 10ft. (2.4 - 3.0m)	Not Recommended		8 x 10 ft. (2.4 x 3.0m)

**Note:** When sizing the number of heaters to warm the patio, the area coverage given above may not provide the stated temperature rise under all weather conditions and will be dependent on heater placement. Minimums are shown as a guideline for human comfort.

## 8.0) TYPICAL HEATER LAYOUTS

The diagrams below show the recommended spacing layout between heaters.

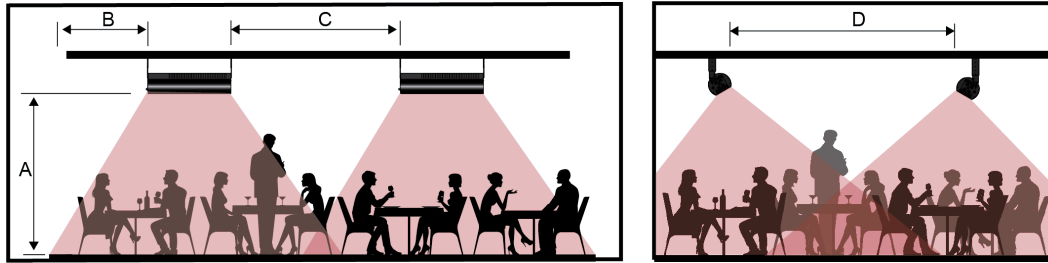

### Models RIHP35:

Dimension	Horizontal		15 to 30° angle		Above 30° angle	
	Min.	Max.	Min.	Max.	Min.	Max.
A. Mounting Height	8ft (2.4m)	11ft (3.4m)	7ft (2.1m)	9ft (2.7m)	6ft (1.8m)	8ft (2.4m)
B. Distance to the end of the patio	0ft (0m)	6ft (1.8m)	0ft (0m)	6ft (1.8m)	0ft (0m)	6ft (1.8m)
C. Distance between heaters.	8ft (2.4m)	12ft (3.7m)	7ft (2.1m)	11ft (3.4m)	6ft (1.8m)	10ft (3.0m)
D. Distance between heaters*	8ft (2.4m)	16ft (4.9m)	8ft (2.4m)	18ft (5.5m)	8ft (2.4m)	16ft (4.9m)

\*Note the distance D for angled heaters applies when they are facing towards each other.

Note: Local codes may have special requirements regarding head clearance requirements. Some local codes require all portions of overhead radiant heaters to be located at least 8 feet above the floor.

### Models RIHP50:

Dimension	Horizontal		15 to 30° angle		Above 30° angle	
	Min.	Max.	Min.	Max.	Min.	Max.
A. Mounting Height	9ft (2.7m)	12ft (3.7m)	8.5ft (2.6m)	11ft (3.4m)	8ft (2.4m)	10ft (3.0m)
B. Distance to the end of the patio	0ft (0m)	8ft (2.4m)	0ft (0m)	8ft (2.4m)	0ft (0m)	6ft (1.8m)
C. Distance between heaters.	8ft (2.4m)	14ft (4.3m)	7ft (2.1m)	13ft (4.0m)	6ft (1.8m)	12ft (3.7m)
D. Distance between heaters*	8ft (2.4m)	16ft (4.9m)	10ft (3.0m)	20ft (6.1m)	10ft (3.0m)	18ft (5.5m)

\*Note the distance D for angled heaters applies when they are facing towards each other.

Note: Local codes may have special requirements regarding head clearance requirements. Some local codes require all portions of overhead radiant heaters to be located at least 8 feet above the floor.

Below are examples of patio heating applications.

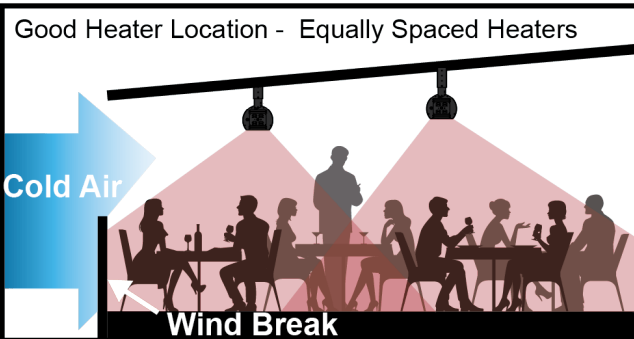
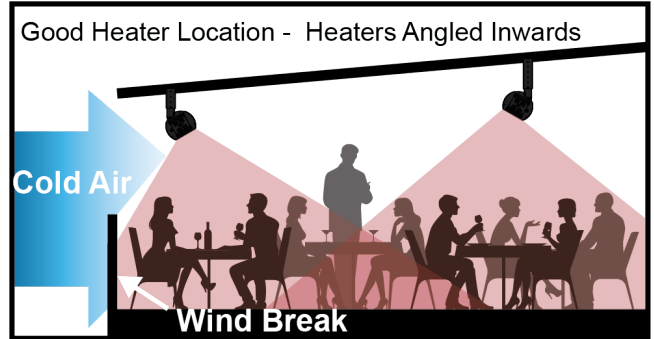
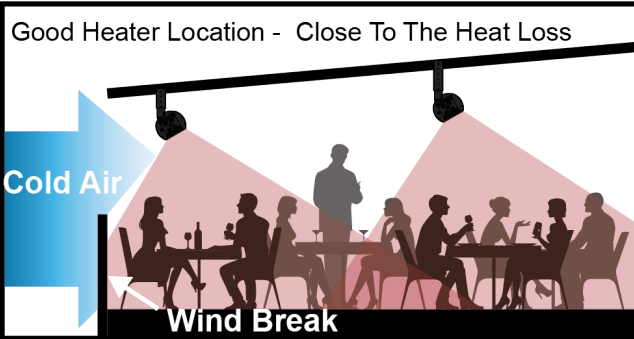
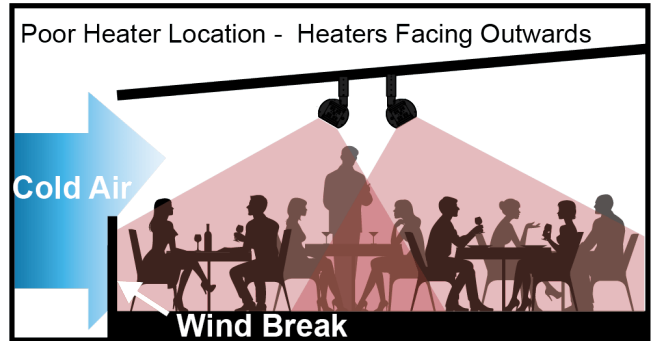
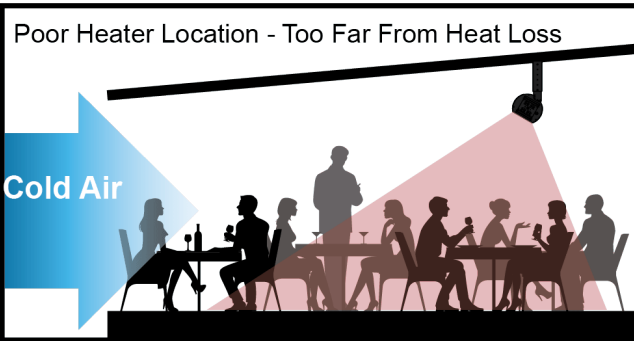

**Positioning Tips**

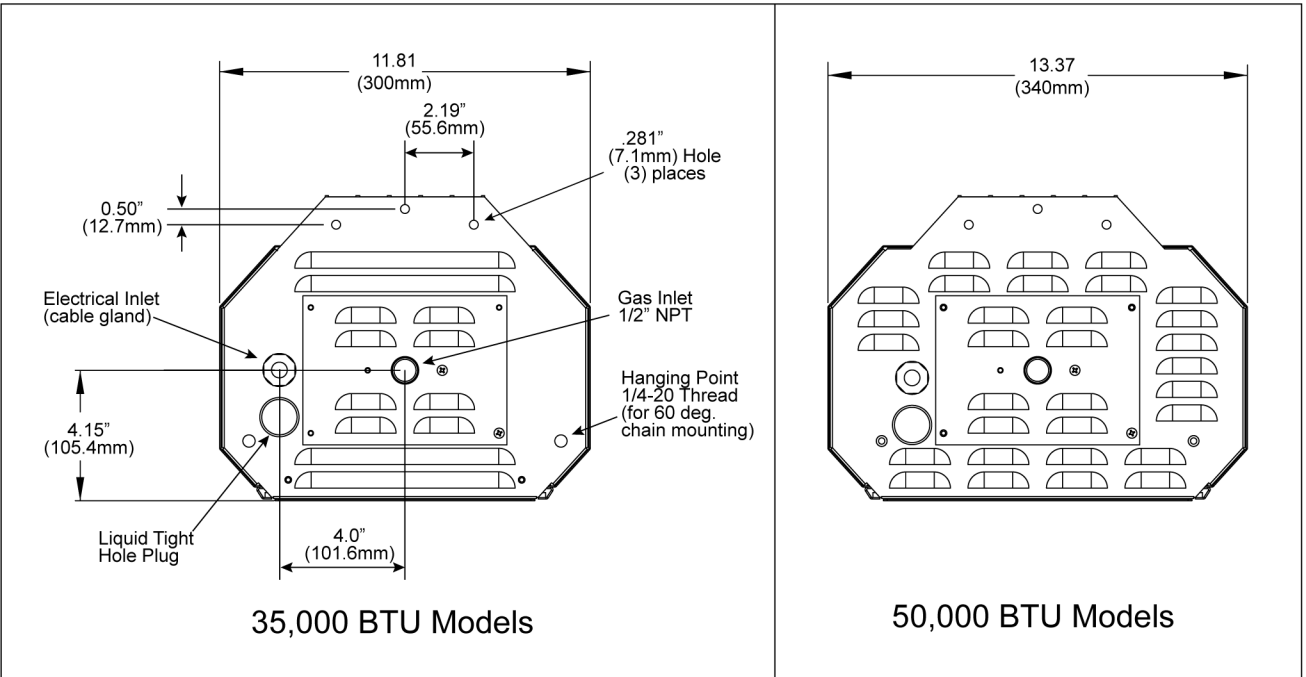
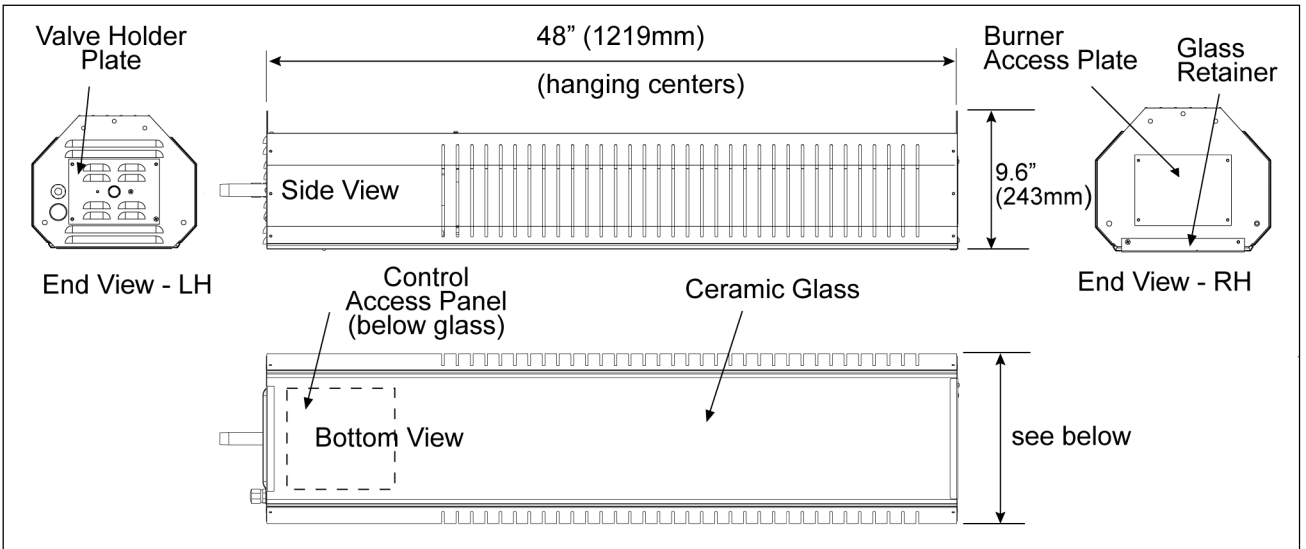

1. Avoid Direct wind, position wind breaks where possible. Wind breaks must not effect clearance to combustibles or ventilation.
2. Heaters mounted horizontally will radiate the most heat. The greater the mounting angle the lower the intensity.
3. Use mounting height and area coverage information to select the correct number of heaters.

## 9.0) DIMENSIONS

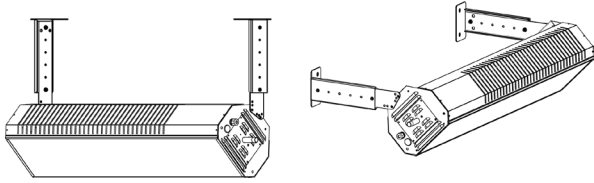
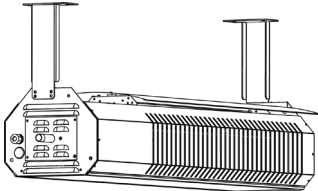
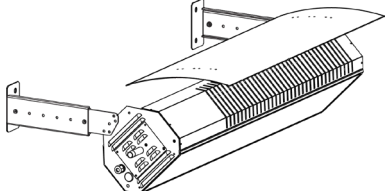
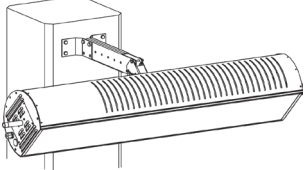
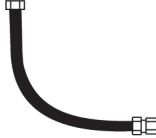

## 10.0) ACCESSORIES

Below are the optional accessories available for the Reznor RIHP Patio heater.

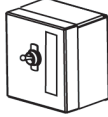
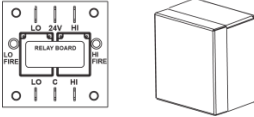
1047564R	Wall / Ceiling Telescopic Mounting Bracket Kit- 15"-30" overhead space (check clearances to combustibles space above the heater before ordering) includes both the 15-22" and 22-30" extension legs.	
1047563R	Ceiling Mount Bracket Kit- 10" fixed installation for minimum overhead clearance. This bracket is only for horizontal mounting with the heat shield	
1047561R RIHP 1047562R RIHP50	Heat Shield Kit - Reduced clearances to combustible option when installed. Mounting angles are restricted to 0, 15, 30, 45 and 60°.	
1047565R	Column Mounting Arm Kit - suitable for columns 8" and wider.	
1047558R	Gas Connector-Black Powder Coated Paint to match the heater. 1/2"OD -24" Long with 1/2MIP X 1/2 FIP Connection	
1047559R	Gas Connection Kit- 1/2"-Includes Gas Connector, Manual Ball Valve, Sediment Trap (Tee, Cap, Nipple), Thread Sealing Compound	
1047560R	Gas regulator 2psig to 11" w.c. 1/2" NPT inlet and outlet.	
1047555R	3 Position Switch Kit, (High/Low/Off) for manual heater control. Included with Remote Models	
1047556R	Two Stage Relay Kit controlling multiple heaters with a single 24V Two Stage thermostat.	

## 11.0) UNPACKING THE HEATER

**CAUTION** The heater and ceramic glass are shipped separate but in the same box. Care must be taken when un-packing the heater. Carefully open the top of the heater as indicated on the labels at the side of the shipping box. An angle gauge is attached to the heater's control side with tape and is needed for installation (see Section 12.1).

The glass is located to the side of the heater and is wrapped in cardboard cradled into the foam end pieces. Carefully remove the top foam pieces and remove the cardboard wrapped glass. Care must be taken that during handling the glass does not slide out of the cardboard wrap. Store the glass in a secure location for later assembly.

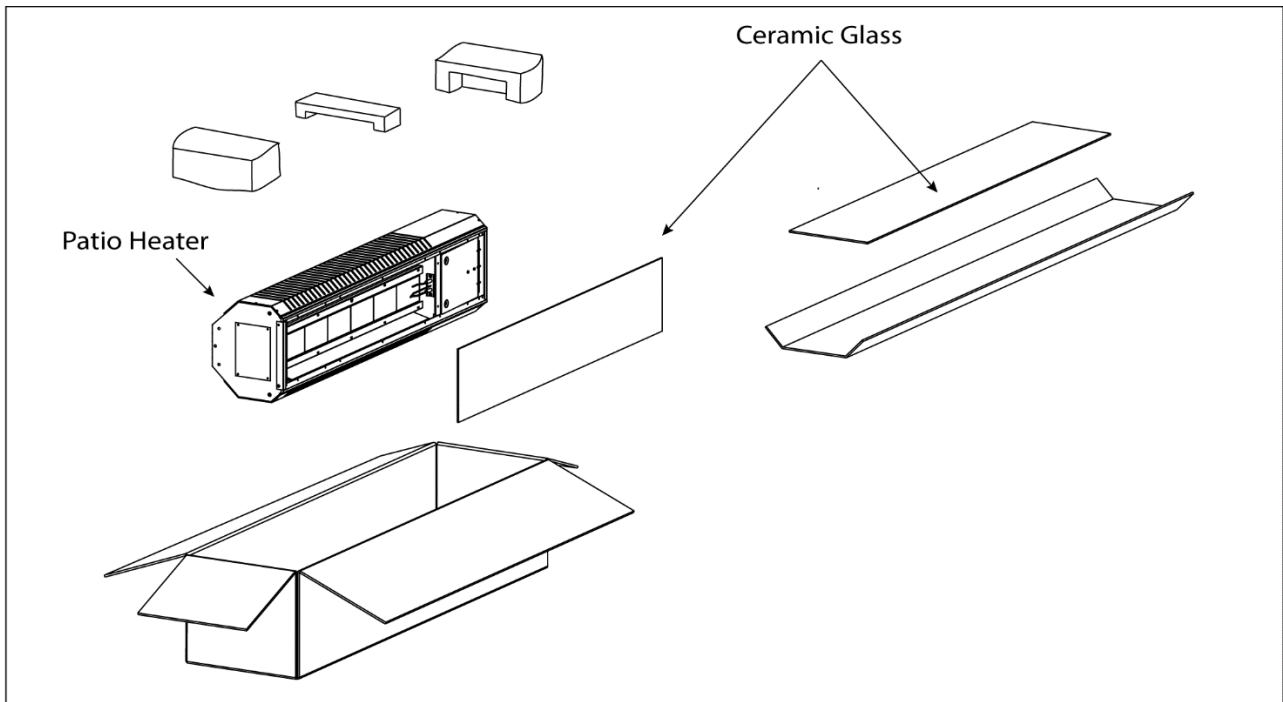

**CAUTION** It is recommended that two people lift the heater out of the carton. Do not remove from the remaining packaging until the heater is ready to be hung.

## 12.0) INSTALLATION

<b>⚠ WARNING</b>	
 Crush Hazard	<p>All materials used to suspend the heater must have a minimum working load of 115 lbs. All "S" hooks must be crimped closed.</p> <p>Never use the heater to support a ladder or other access equipment.</p> <p>Always suspend from a permanent part of the building structure that can support the total force and weight of the heater.</p> <p>Never use chain to suspend the heater outdoors.</p> <p>Failure to do so may result in death, serious injury or property damage.</p>

To protect the ceramic glass, it is recommended to only insert the ceramic glass once all the other installation steps have been completed. The ceramic glass must be removed to wire the heater and for commissioning. Various means of suspending the heater can be used. See the following drawings for typical examples.

- a) Heaters installed outdoors or in areas subject to strong winds must be installed using the optional hanging brackets or suitable rigid mount hardware. Chain, cable and other flexible hanging methods are not recommended.
- b) Use only noncombustible materials for suspending hangers and brackets.
- c) Heaters must not be supported by gas or electric supply lines and must be suspended from a permanent structure with adequate load capacity.
- d) Hanging points are a fixed length between centers. Secondary steel work may be required to span between supporting beams.
- e) The appliance should be located with respect to building construction and other equipment to permit access to the appliance for servicing etc.
- f) The heater must be installed in an adequate free area to allow the products of combustion to freely escape from the heater. The heater must not be installed in recessed spaces or enclosure and alcoves.
- g) The heater must be suspended with its longitudinal axis horizontal but may have its lateral axis at an angle from 0° to 60° from the horizontal, as shown in the minimum clearances to combustibles section 4.0).
- h) An optional heat shield may be installed to reduce the top distance of clearance to combustibles. This heat shield should be installed prior to hanging the heater. When using the heat shield at the minimum clearance distance the angles of installation are restricted to 0, 15, 30, 45 and 60°.
- i) Use the provided angle gauge to ensure that the heater is hung at the approved installation angles.
- j) The heater can be angle mounted on both sides of its lateral axis.
- k) Hanging brackets should first be fixed to the wall surface by means of 4 lag bolts – not supplied (3/8" x 1-1/2" minimum) through pre-formed holes in each of the brackets prior to installing heater.

## 12.1) HEATER MOUNTING ANGLE

**! WARNING**



**Fire and Explosion Hazard**

Heat shield must be installed in the correct position for the installation angle. Failure to mount the shield correctly will result in higher surface temperatures and exceed the clearances to combustibles.

Approved installation angles are 0, 15, 30, 45 and 60 degrees with the heat shield installed.

Failure to do so may result in fire and/or explosion, property damage, serious injury or death.

Every heater is supplied with an angle gauge. The gauge is attached with tape to the heater control side.

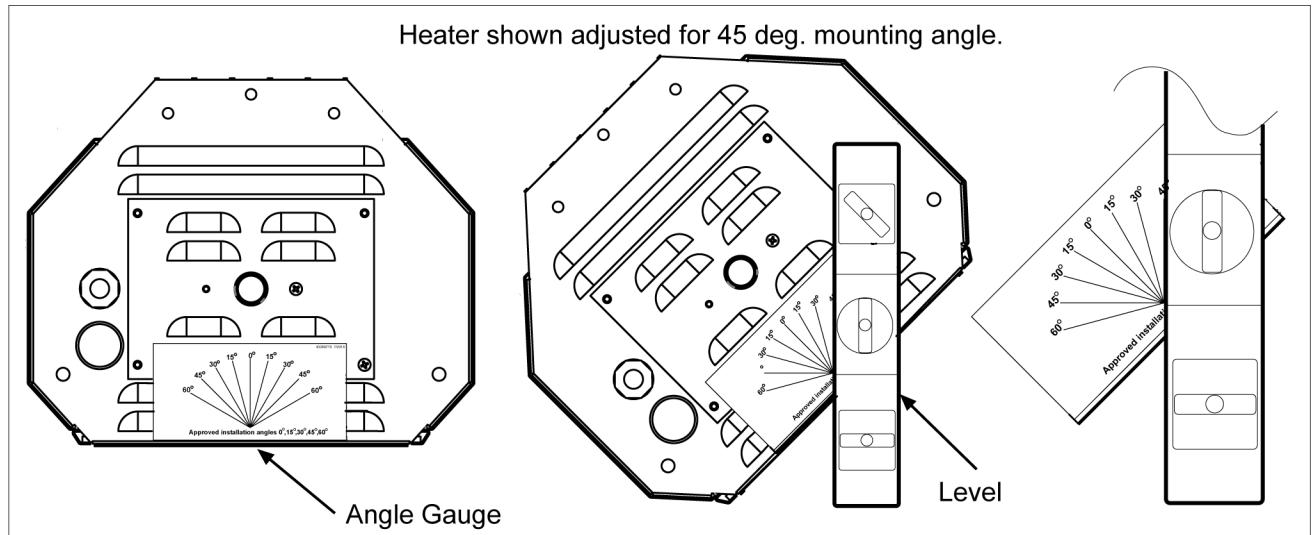

The angle gauge is used in combination with a level to ensure that the heater is installed at one of the mounting angles of 0°, 15°, 30°, 45° and 60°.

Hold the side of the angle gauge without label flush against the glass surface. Hold a level against the other side of the angle gauge and find the desired installation angle of the heater. Verify that the level is vertical, adjust heater angle if needed.

Note: If a heat shield is installed its location must match the heaters angle (see Section 21.0).

This process must be repeated for both ends of the heater.

## 12.2) INDOOR INSTALLATION – HANGING METHODS

When the heater is used for an Indoor Installation then the following hanging methods may be used.

The heater can be hung from the ceiling, secondary steel work, etc. using chains, threaded rods, and other approved hanging materials. All hanging materials must have a minimum working load of 115 lbs. Any "S" hooks must be crimped closed after installation.

Note:

When hanging the heater hanging materials which allow the heater to move the gas connection must be established using an approved flexible gas hose of a minimum of 24" length.

Diagram below shows Horizontal mounting with chain.

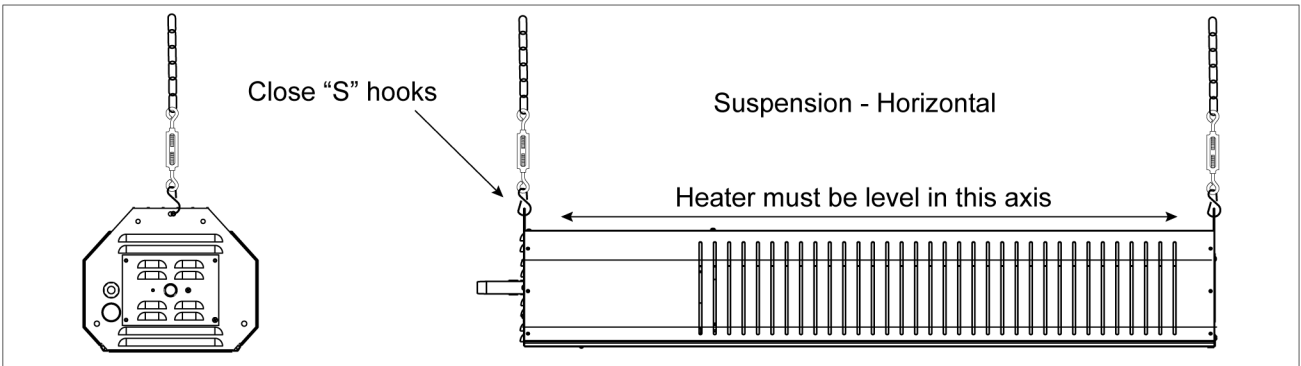
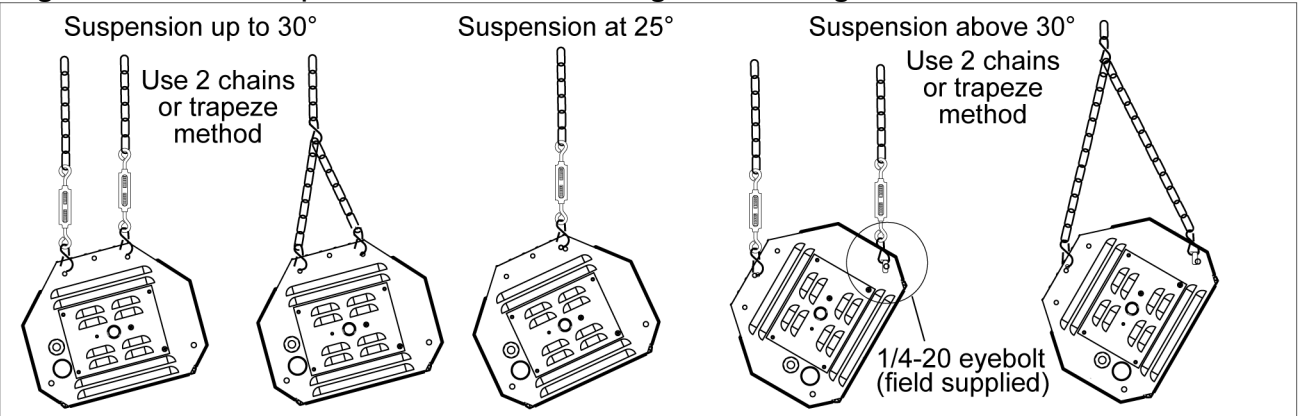

Diagram below shows the possible chain methods to hang at different angles.



Notes: When suspending at 25 degrees if the heat shield is installed use the 30-degree location for the heat shield.

## 12.3) INDOOR / OUTDOOR RIGID HANGING BRACKETS

Fixed hanging methods which prevent the heater from swaying must be used for outdoor installations.

Below are the bracket kits which can be used for ceiling and wall mount for patio heaters installed indoors and outdoors, with and without heat shields. The brackets provide for a range of lengths and approved mounting angles of 15°, 30°, 45° and 60°.

- 1047564R KIT, BRACKET - WALL/CEILING 15"-30" CEILING - FOR USE WITH HEAT SHIELD (telescoping)
- 1047563R KIT, BRACKET - CEILING 10" - FIXED (for outdoor only horizontal ceiling mount with heat shield)

The hanging brackets are supplied as an optional accessory item. Below are the kit contents.

Item No.	Part No.	Description	04601530 Quantity	04601010 Quantity
1		HHCS, 1/4-20 x 1/2" SS	4	4
1a		HHCS, 1/4-20 x 1-1/2" SS	4	-
2		WASHER, FLAT 1/4"N SS	16	8
3		LOCKNUT, 1/4-20 KEPS - SS	8	4
4	04660209	HANGER BRACKET - RECEIVER	2	-
5	04660269	SLIDER ARM - LH (15.75")	1	-
6	04660279	SLIDER ARM - RH (15.75")	1	-
7	04660289	SLIDER ARM - LH (23.75")	1	-
8	04660299	SLIDER ARM - RH (23.75")	1	-
9	04660809	FIXED ARM (10")	-	2

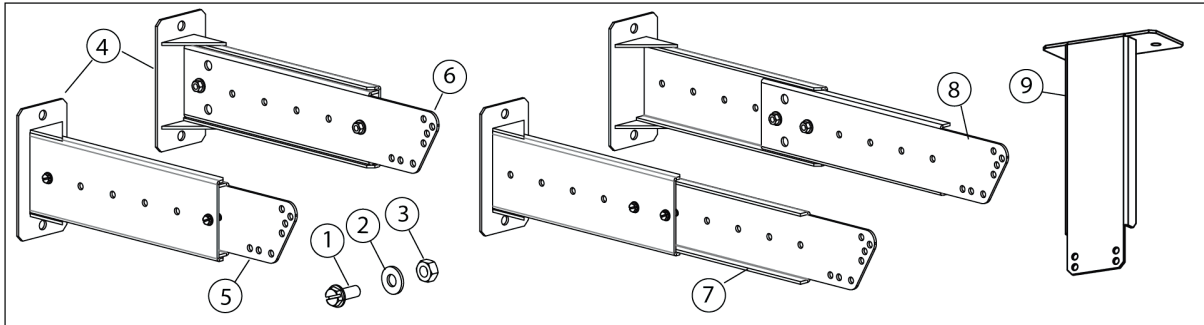

The tables below can be used to select the correct bracket to ensure that the heater is installed at the correct clearance to combustible distance from the ceiling depending on whether the heater is installed indoors or outdoors, the mounting angle and whether a heat shield is installed.

Mounting Angle	15-22" Bracket (With heat shield) telescope hole positions*		22-30" Bracket (Without heat shield) telescope hole positions*	
	INDOOR	OUTDOOR	INDOOR	OUTDOOR
0	1 to 5	1 to 5	3 to 5	1 to 5
15 and 30	2 to 5	1 to 5	3 to 5	1 to 5
45 and 60	4 or 5	2 to 5	4 or 5	2 to 5

\* The above table relates to the holes positions as shown in the figure below for the two different length adjustable brackets.

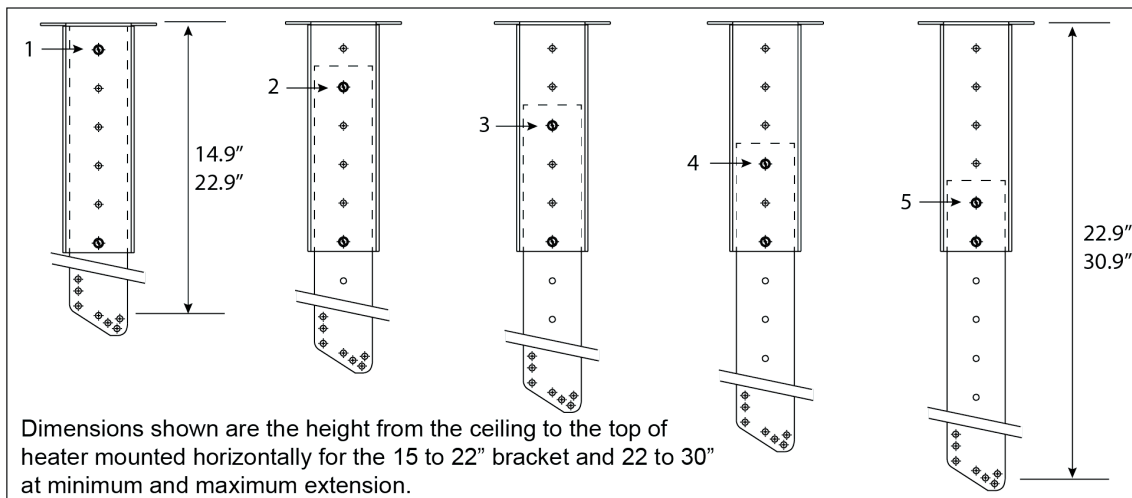

### 12.3.1) HANGING BRACKETS ASSEMBLY

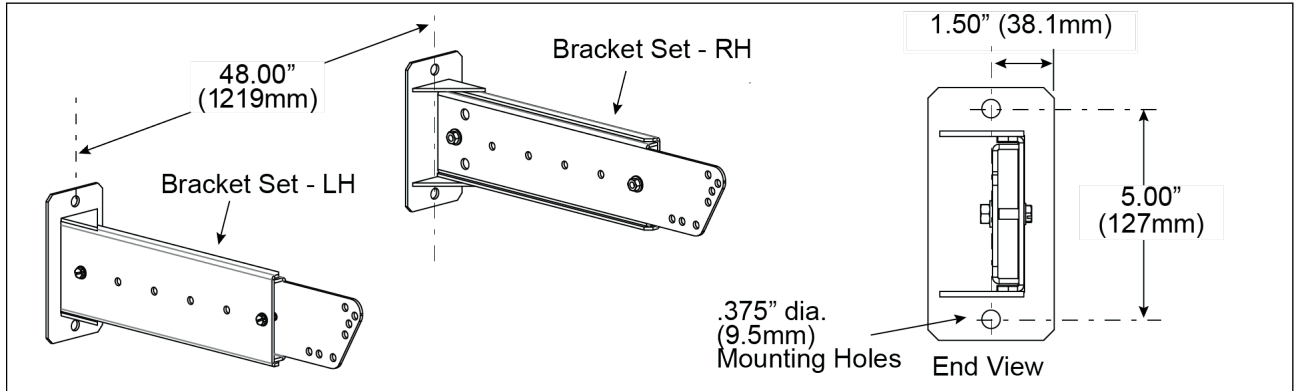

A left-hand LH and right-hand RH bracket must be assembled. Torque screws and locknuts to 5 lb/ft.

To mount the hanging brackets to the wall/ceiling:

1. Measure and mark distances for the hanger bracket holes.
2. Hanging brackets should first be fixed to the wall or ceiling surface by means of 4 lag bolts – (not supplied) (3/8" x 1-1/2" minimum) through pre-formed holes in each of the brackets prior to installing heater. All hanging materials must have a minimum working load of 115lbs.

### 12.3.2) HEATER ATTACHMENT TO HANGING BRACKETS

The heater can be attached to the hanging brackets in angles of 15°, 30°, 45° and 60°. Choose the desired heater mounting angle and find the corresponding hole pattern as per the wall and ceiling mount figures below.

**CAUTION** When angle mounting the heater, the radiant output will decrease approximately by following:

Mounting Angle	15 degree	30 degree	45 degree	60 degree
Radiant output reduction	3%	13%	29%	50%

Attach the heater to the brackets using (2) cap screws, flat washers and locknuts provided in the kit. Torque screws and locknuts to 5 lb-ft. Minimum clearances to combustibles must be observed. See Section 4).

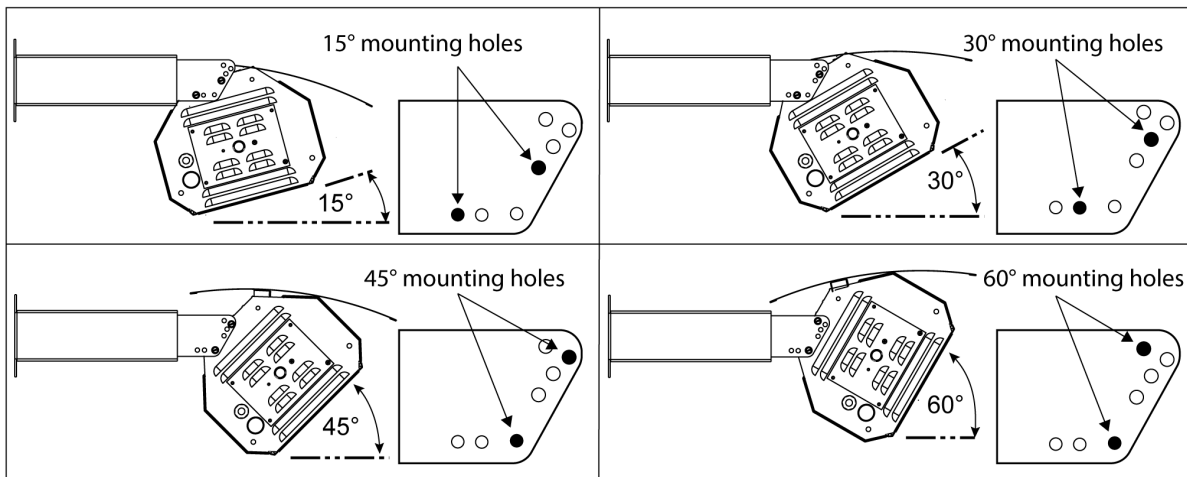

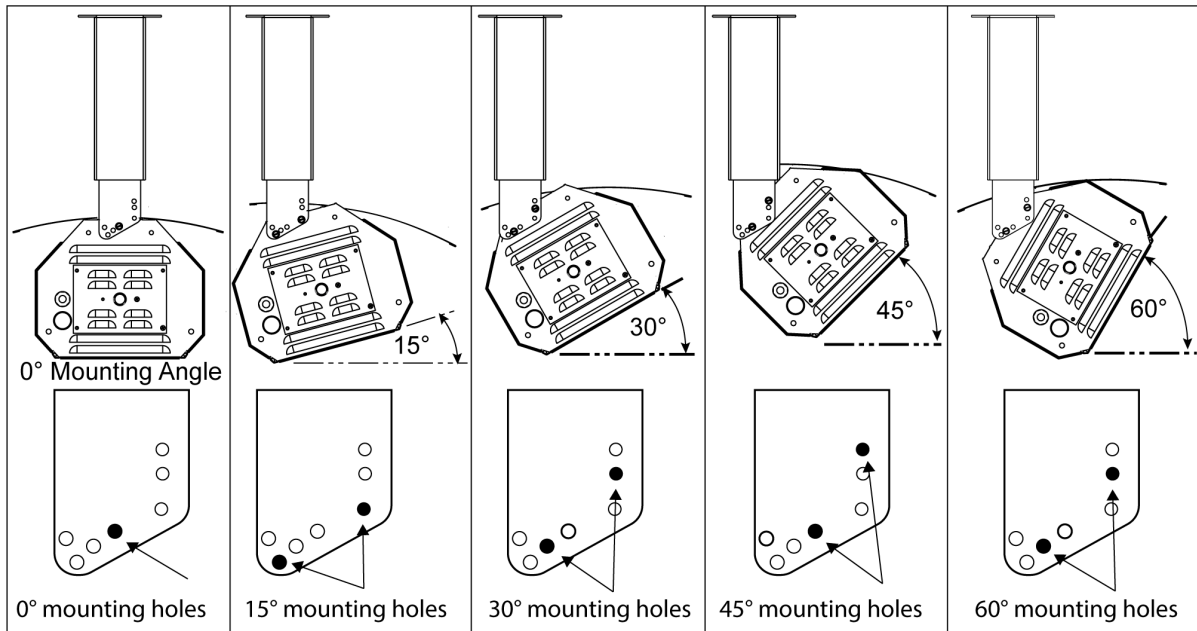

### 13.0) HEAT SHIELD INSTALLATION

**⚠ WARNING**



**Fire and Explosion Hazard**

Heat shield must be installed in the correct position for the installation angle. Failure to mount the shield correctly will result in higher surface temperatures and exceed the clearances to combustibles.

Approved installation angles are 0, 15, 30, 45 and 60 degrees with the heat shield installed.

Failure to do so may result in fire and/or explosion, property damage, serious injury or death.

A heat shield can be used to reduce the clearance to combustible distances. Refer to Minimum Clearance to Combustibles in Section 4). The heat shield is available as an accessory kit. See below

Item No.	Part No.	Description	Kit No. 44566300 GGE35	Kit No. 44566400 GGE50
1		#10-24 ACORN NUT	2	2
2		TEFLON WASHER	4	4
3		#10-24 SS LOCKNUT	2	2
4		PHSMS #8 x 1/2" AB POINT SS - BLK OXIDE	8	8
5	04668139	RAIL - HEAT SHIELD HANGER - PAINTED	1	1
6	04666189	HEAT SHIELD - ROLLED - PAINTED (15.19 CHORD)	1	-
6a	04666309	HEAT SHIELD - ROLLED - PAINTED (19.19 CHORD)	-	1

7	04668149	HOLDER BRACKET - PAINTED (7.00 WIDE)	2	-
7a	04668159	HOLDER BRACKET - PAINTED (8.56 WIDE)	-	2
8	43247112	LABEL, INDOOR CLEARANCES (with heat shield)	1	-
8a	43247114	LABEL, INDOOR CLEARANCES (with heat shield)	-	1

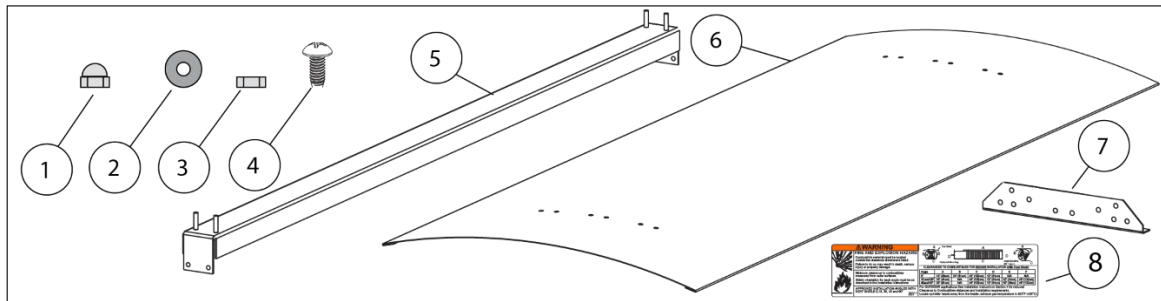

The heat shield position on the heater is dependent on the heater mounting angle. Use the angle gauge provided with the heater to determine the mounting angle before proceeding with the heat shield assembly. See Section 12.1

See below for installation steps.

Step 1. Use the angle gauge shown below to determine the mounting angle of the heater.

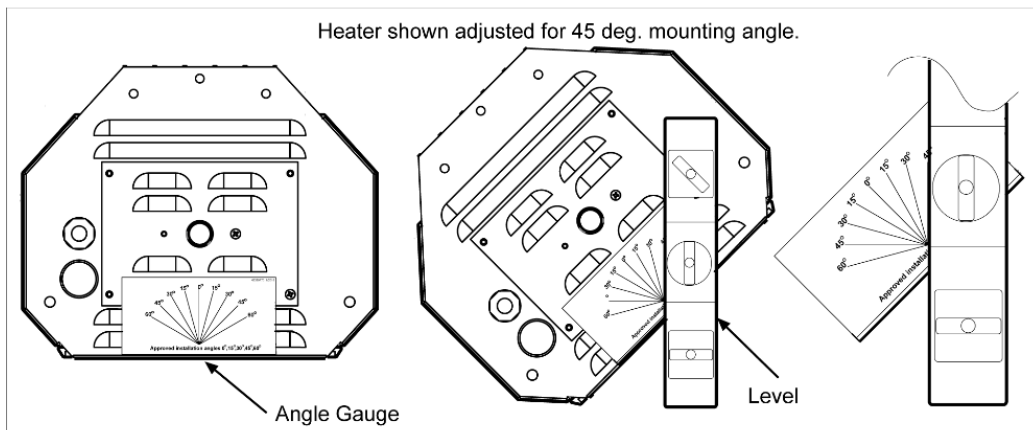

Step 2. Attach the (2) holder brackets to the top of the heater using (2) black oxide #8 screws per bracket.

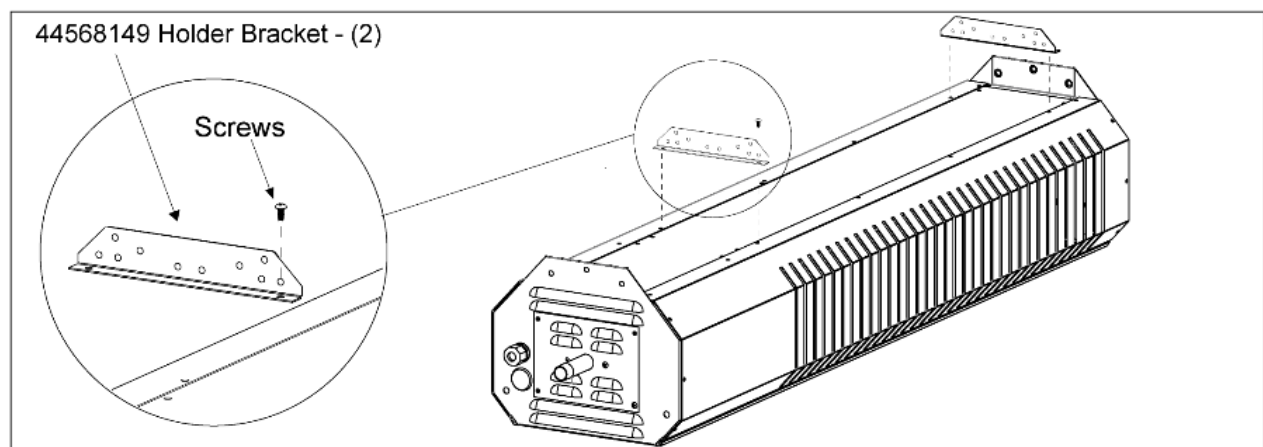

Step 3. Identify the correct holes to mount the shield hanger rail from the illustration below.

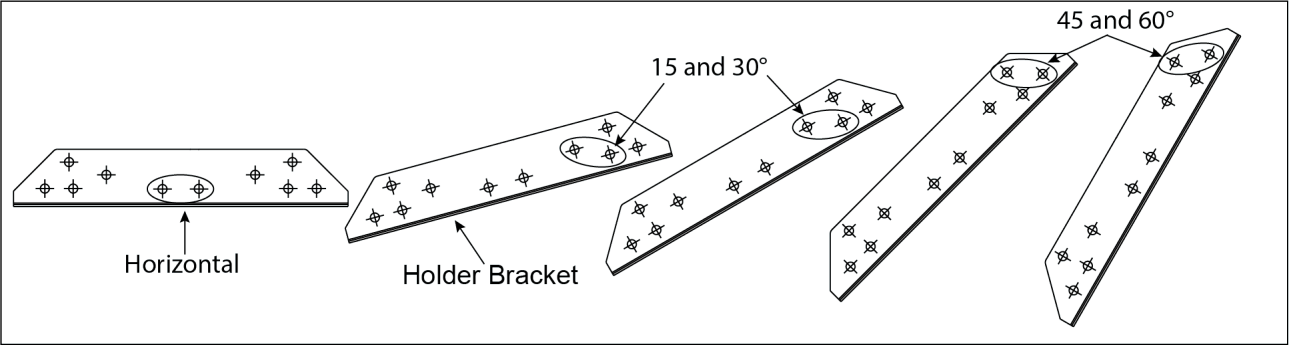

Step 4. Attach the heat shield hanger rail to the holder bracket using (2) black oxide #8 screws on each end. Horizontal position shown below.

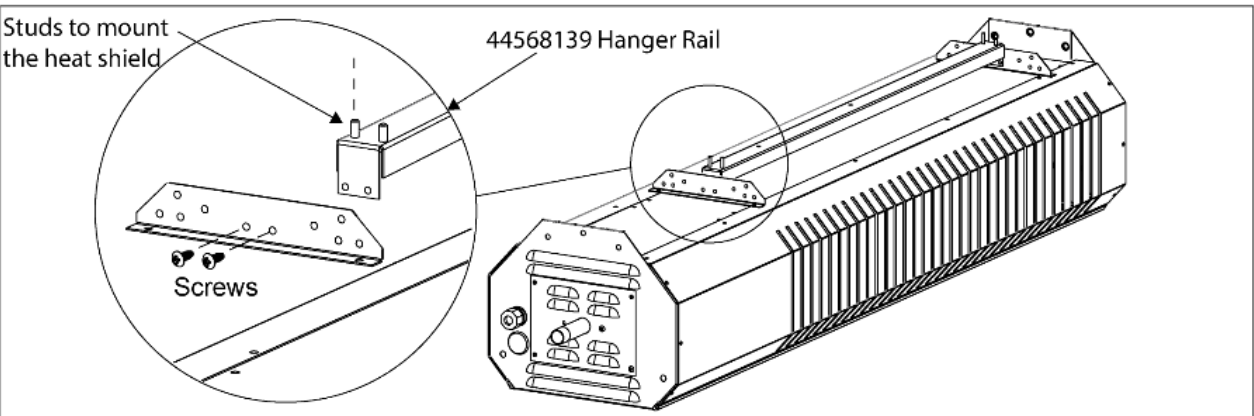

**CAUTION** IMPORTANT: Use the **Acorn nuts** at the control end of the heater as shown in the illustrations so that the heat shield can expand when the heater is turned on. Failure to do so may result in the heat shield distorting.

Step 5. Attach the heat shield to the hanger rail using the holes in the heat shield indicated below for horizontal mounting.

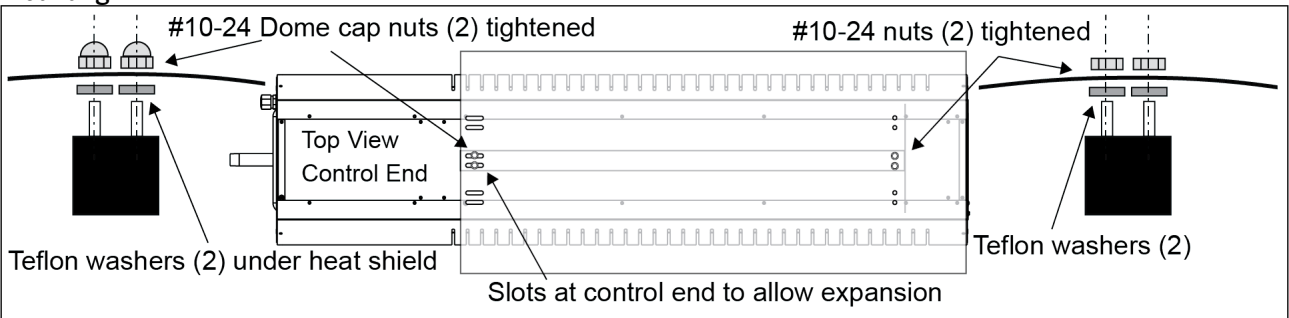

Step 6. Place the new clearance label on the control end of the heater. **NO NOT PLACE LABEL ON THE HEAT SHIELD.**

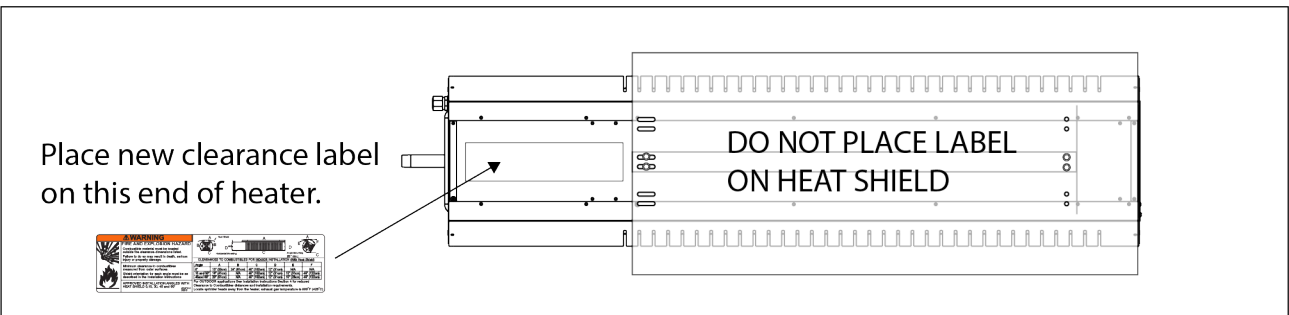

See below the correct holes to mount the heat shield to the hanger rail for other installation angles.

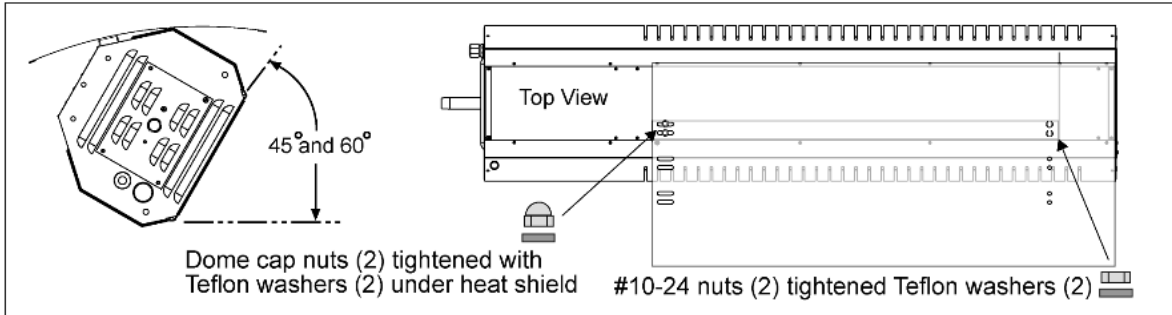
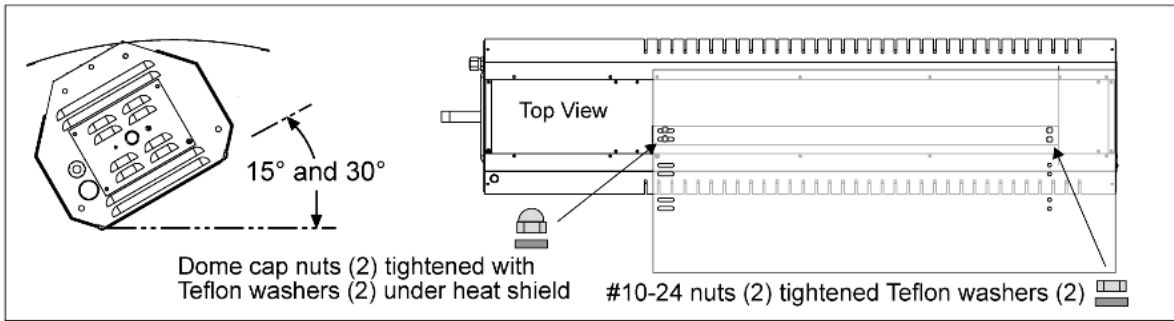

**Note: When in operation the heat shield will deform slightly when installed at a mounting angle of 45 or 60 degrees. This is normal. After operation the heat shield should return to its normal shape.**

## 14.0) ASSEMBLY OF THE CERAMIC GLASS

Only install the ceramic glass once the heater has been attached to a suitable gas (see Section 15.0), electrical supply (see Section 16.0) and has been commissioned (see Section 18.0).

Read this section to the end to avoid glass breakage.

1. Locate the “Glass Access Retainer” and carefully remove with a suitable Phillips screwdriver the two (2) black oxide sheet metal screws holding it in place. Retain screws and Glass Access Retainer for later.
2. The side of the glass where the logo is attached must be slid in first for the logo’s final position to be at the control side of the heater.
3. Slide the glass into the “Glass Retainer Rails”. The glass must be held parallel to the Glass Retainer Rails during assembly. The glass will slide in easy with ample clearance. Slide the glass until it is positioned under the Glass Retainer at the heaters control enclosure side. At this point the glass will be flush with the heater at the insertion point.

**Note: If the ceramic glass does not slide in easily review position of ceramic glass to glass retainers and adjust if needed. Do not force the ceramic glass into the glass retainers!**

4. Reinstall the Glass Access Retainer removed in 1. with the two (2) sheet metal screws.

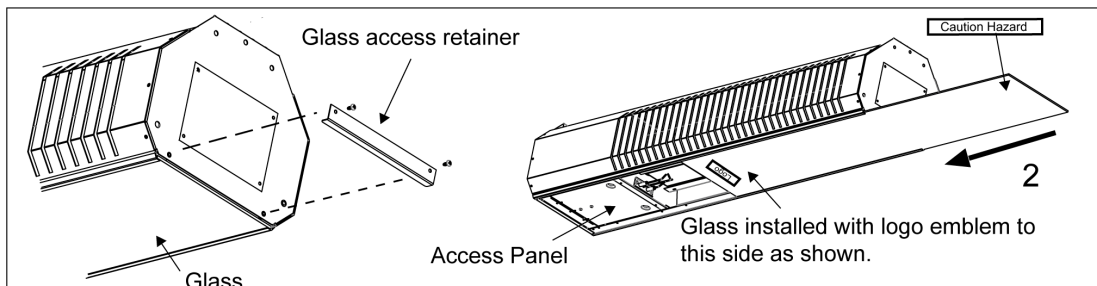

## 15.0) GAS CONNECTIONS AND REGULATION

**⚠ WARNING**



**Fire and Explosion Hazard**

An approved connector, suitable for the environment of equipment usage, is required. Visible or excessive swaying, flexing and vibration of the gas connections must be avoided to prevent failure. Neither the gas pipe nor the connector shall be placed in the "flue discharge area". In no case shall the gas supply support the weight of the heater.

Leak test all components of gas pipe work before operation.

Failure to do so may result in death, serious injury or property damage.

**⚠ WARNING**



**Fire and Explosion Hazard**

Tighten the flexible gas hose, gas piping and components securely.

Improperly connected gas lines may result in fire, explosion, poisonous fumes, toxic gases, asphyxiation or death. Connect gas lines in accordance to national, state, provincial and local codes.

Failure to do so may result in death, serious injury or property damage.

**⚠ WARNING** Use an approved flexible gas connector of 24" minimum length when installing the heater with flexible hanging methods as described in Section 12.0).

### IMPORTANT BEFORE CONNECTING THE GAS TO THE HEATER

- Connect to the supply tank or manifold in accordance with state or local building codes. Authorities having jurisdiction should be consulted before the installation is made. (In Canada, refer to the latest edition of CSA B149.1, Natural Gas and Propane Installation Code.)
- Check that the gas fuel on the burner rating plate matches the fuel for the application.
- Check that the gas supply piping has the capacity for the total gas consumption of the heaters and any other equipment connected to the line.
- Check that the calculated supply pressure with all gas appliances and heaters operating will not drop below the minimum supply pressure required for these heaters. See table below.

GAS PRESSURE TABLE				
GAS TYPE	MANIFOLD PRESSURE		SUPPLY PRESSURE	
	High	Low (2-stage only)	Minimum*	Maximum
Natural Gas	6.0" W.C.	2.8" W.C.	7" W.C.	14" W.C.
Propane Gas	11.0" W.C.	5.0" W.C.	11.5" W.C.	14" W.C.

- All gas supply lines must be in accordance with the required clearances to combustibles from the heater as listed on the clearances label of the heater and Section 4.0) of this manual.
- Pipe joint compounds must be resistant to the action of liquefied petroleum gases.
- The heater will move when installed with flexible hanging methods, see Section 12.0). Use an approved flexible connector for connections between the rigid piping and the heater. An approved shut off valve should be installed within 6ft of the heater.
- The gas pipe, flexible hose and connections must be self-supporting. The gas pipe work must not bear any of the weight of the heater or any other suspended assembly.



- i) This appliance is equipped with a fast-opening, combination gas valve. **The maximum supply pressure to the appliance is 14" W.C. (1/2 psig)** If the line pressure is more than the maximum supply pressure, then a second stage regulator which corresponds to the supply pressure must be used
- j) After all gas connections have been made, make sure the heater and all gas outlets are turned off before the main gas supply is turned on slowly. Turn the gas supply pressure on and check for leaks.
- k) If a 2nd stage regulator is used, the ball valve before the heater in the supply line must be closed when purging the gas lines to prevent gas seeping through it. If initial gas pressure is higher than 14" W.C. the redundant combination gas valve is designed to lock out. Pressure build-up in the supply lines prior to the heater must be released before proper heater operation.
- l) High gas pressure regulators need to be installed upstream of flexible gas lines.

**⚠ WARNING** The entire gas supply system must be checked for leaks prior to heater operation. **Do not use an open flame of any kind to test for leaks.**

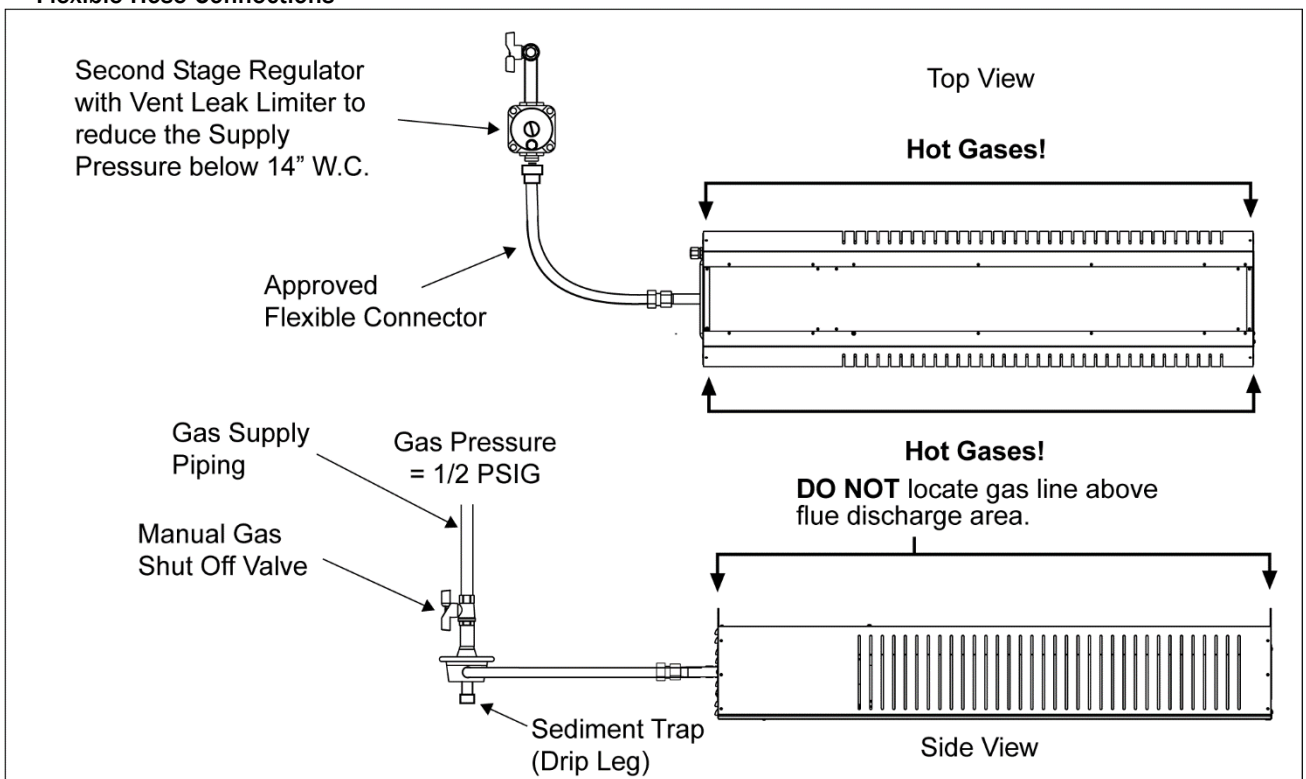
**Flexible Hose Connections**



## 15.1) INSTRUCTIONS FOR PRESSURE TEST GAUGE CONNECTION

<b>⚠ WARNING</b>		
<b>Electric Shock Hazard</b> 	<b>Fire and Explosion Hazard</b> 	<b>Burn Hazard</b> 
<b>Disconnect electric before service.</b>  <b>Heater must be connected to a properly grounded electrical source.</b>	<b>Turn off gas supply to heater before service.</b>	<b>Allow heater to cool 30 minutes before service.</b>  <b>Glass and heater surfaces will still be hot after operation.</b>
<b>Failure to follow these instructions can result in death, serious injury or property damage.</b>		

## 15.2) INLET GAS PRESSURE CHECK

1. The installer will provide a 1/8" N.P.T. tapped plug, accessible for test gauge connection immediately upstream of the gas supply connection to the heater.

## 15.3) OUTLET GAS PRESSURE CHECK AND ADJUSTMENTS

Gauges that measure pressure in pounds per square inch are not accurate enough to measure or set the manifold pressure. All measurements **MUST BE** made when the heater and all other gas burning equipment that are connected to the gas supply system are operating at maximum capacity. The combination gas valve is factory set and should not need adjustment. If gas pressure adjustment is required, follow the instructions:

1. Turn off all electrical power to the system to connect manometer hoses.
2. Turn the pressure test screw (3/32" Hex) in the center of the boss **not more than one turn counterclockwise**. Attach a 5/16" hose and manometer over the tapered outlet pressure boss on the valve (see **Figure 1** below). If regulator needs to be adjusted, see instructions below.

TO ADJUST REGULATOR (two stage gas valves):

1. Turn on power and energize main gas valve solenoid. Do not energize the **HI** solenoid.
2. Remove regulator cover screw from the **low** outlet pressure regulator (see **Figure 1** below) and turn screw clockwise ⤴ to increase pressure, or counterclockwise ⤵ to decrease pressure. Replace regulator cover screw and tighten securely.
3. Energize main gas valve solenoid as well as the **HI** terminal.
4. Remove regulator cover screw from the **high** outlet pressure regulator (see **Figure 1** below) and turn screw clockwise ⤴ to increase pressure, or counterclockwise ⤵ to decrease pressure. Replace regulator cover screw and tighten securely.

**DO NOT EXCEED THE PRESSURES SHOWN IN THE GAS PRESSURE TABLE.**

5. After testing pressure and adjusting the regulator, turn off all electrical power to the system, remove manometer hoses, turn outlet test screw (3/32" Hex) clockwise to seal pressure port. Tighten to 7 in-lb minimum. Turn on system power.

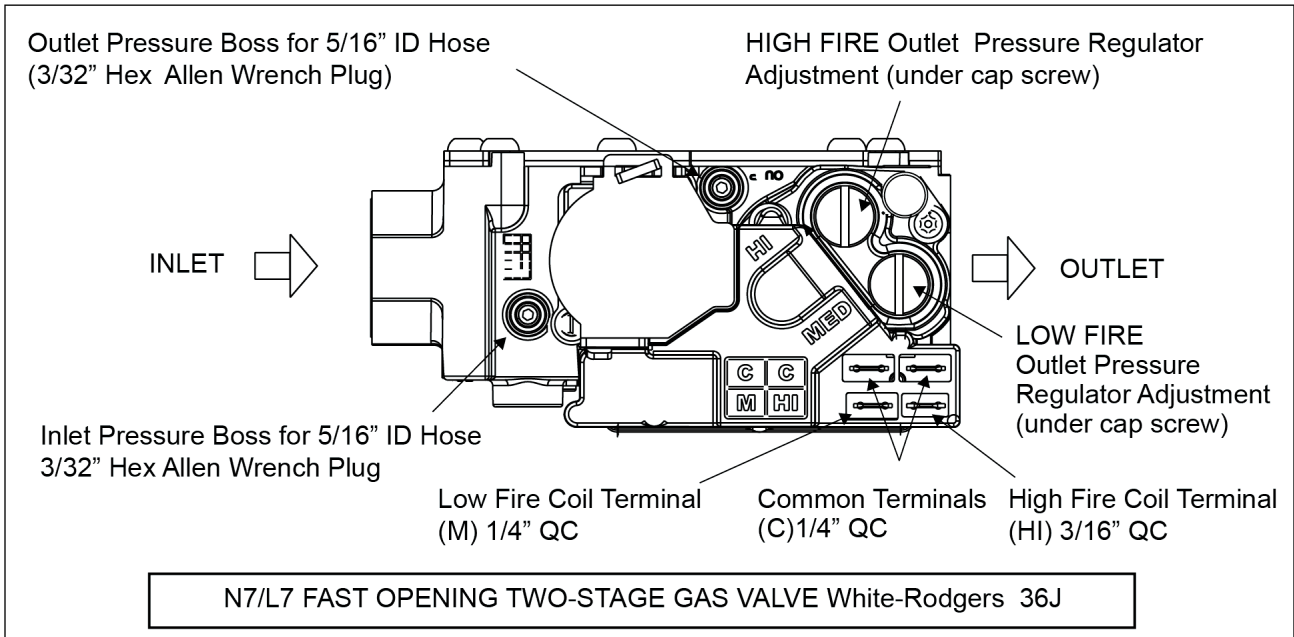

GAS PRESSURE TABLE				
GAS TYPE	MANIFOLD PRESSURE		SUPPLY PRESSURE	
	High	Low (2-stage only)	Minimum*	Maximum
Natural Gas	6.0" W.C.	2.8" W.C.	7" W.C.	14" W.C.
Propane Gas	11.0" W.C.	5.0" W.C.	11.5" W.C.	14" W.C.

Minimum permissible gas supply pressure for purpose of input adjustment.

## 16.0) ELECTRICAL CONNECTIONS

**⚠ WARNING**

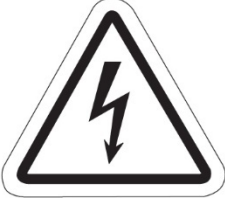

**Electric Shock Hazard**

**Disconnect electrical power and gas supply before servicing.**

**This appliance must be connected to a properly grounded electrical source.**

**Failure to do so may result in death or serious injury.**

1. All electric wiring shall conform to the latest edition of the National Electrical Code (ANSI/NFPA No. 70), or the code legally authorized in the locality where the installation is made.
2. The unit must be electrically grounded in accordance with the National Electrical Code (ANSI/NFPA No. 70-latest edition).

In Canada, refer to current *Canadian Electrical Code*, Parts I and II, and CAN/CSA-C22.2 No. 3 or CAN/CSA-C22.2 No. 60335-2-102:16.

3. The wiring providing power to the heater shall be connected to a permanently live electrical circuit, one that is not controlled by a light switch.
4. The power supply to the unit should be protected with a fused disconnect switch or circuit breaker. A service switch, as required by local codes, shall be in the vicinity of the heater (check local codes for allowable distances) and should be identified as Heater Service Switch. All electrical wiring must be in accordance with the required Clearances to Combustibles below the heater (See section 4).
5. When connecting the supply circuit to the heater, wiring material having a minimum size of 14 AWG and a temperature rating of at least 90°C shall be used.

## 16.1) INTERNAL CONNECTION WIRING DIAGRAM – MODELS WITHOUT REMOTE

The figure below shows the internal wiring diagram of the heater and the optional external connections depending on how the heater will be controlled.

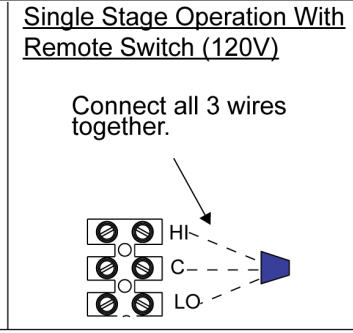
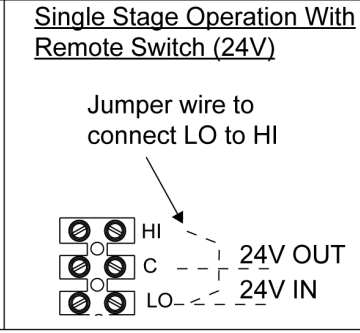
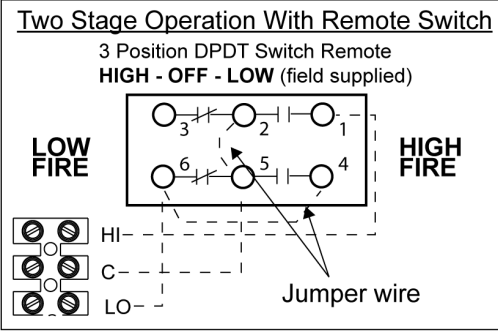
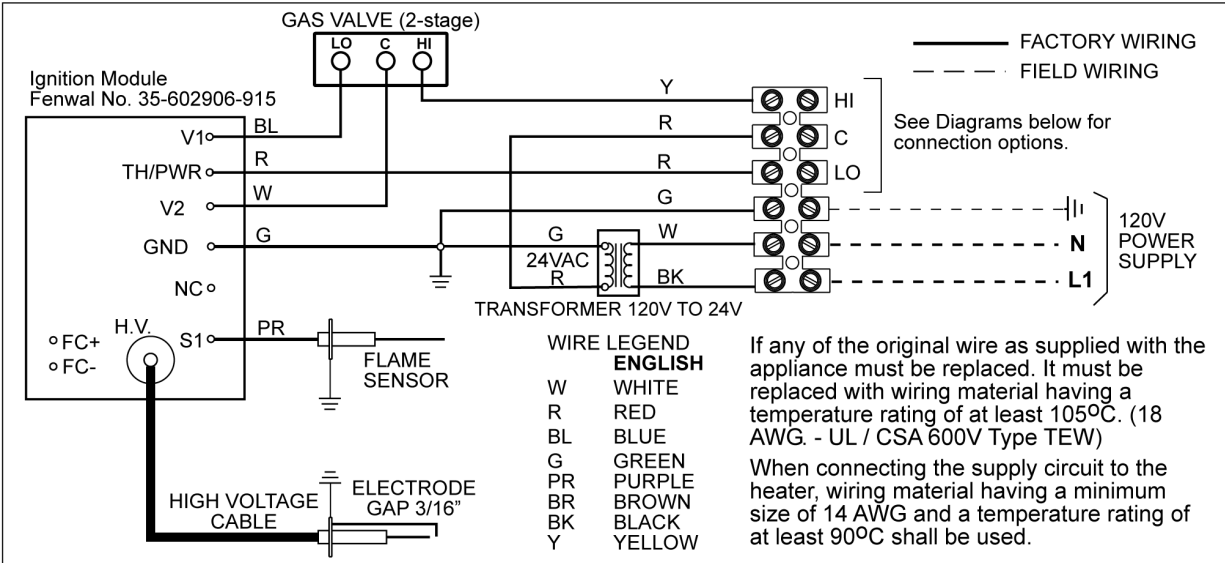

## 16.2) FIELD CONNECTIONS AND WIRING DIAGRAMS – 2 STAGE 24V – MODELS WITHOUT REMOTE

The figure below shows the field wiring connections to the heater terminal block.

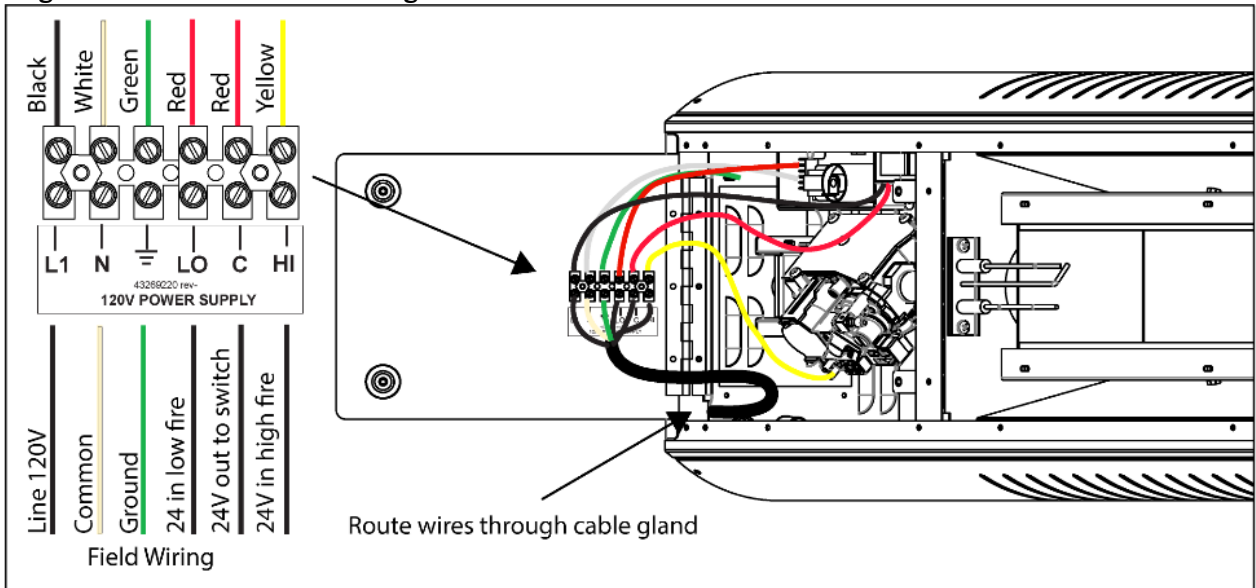

### A. LOW VOLTAGE (24V) 3 POSITION SWITCH CONNECTIONS - SINGLE HEATERS

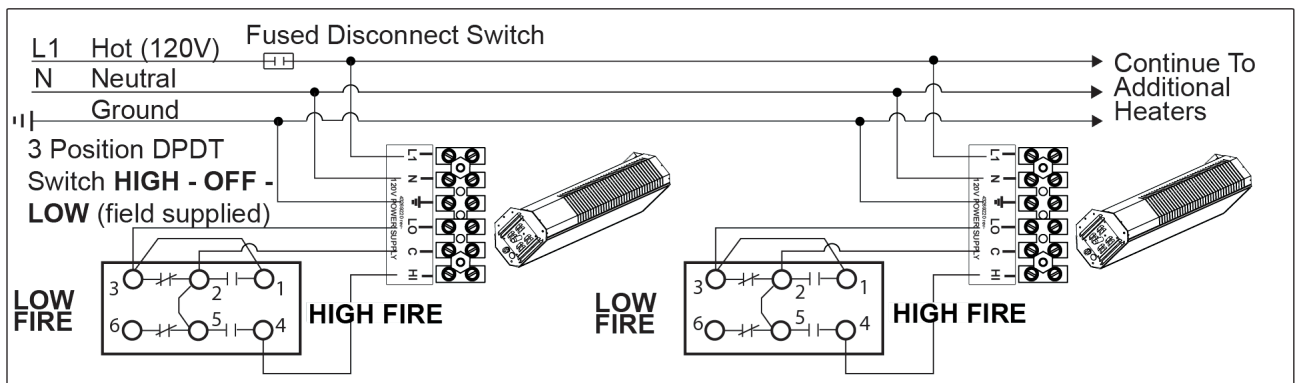

**B. LOW VOLTAGE (24V) 3 POSITION SWITCH CONNECTIONS - MULTIPLE HEATERS**

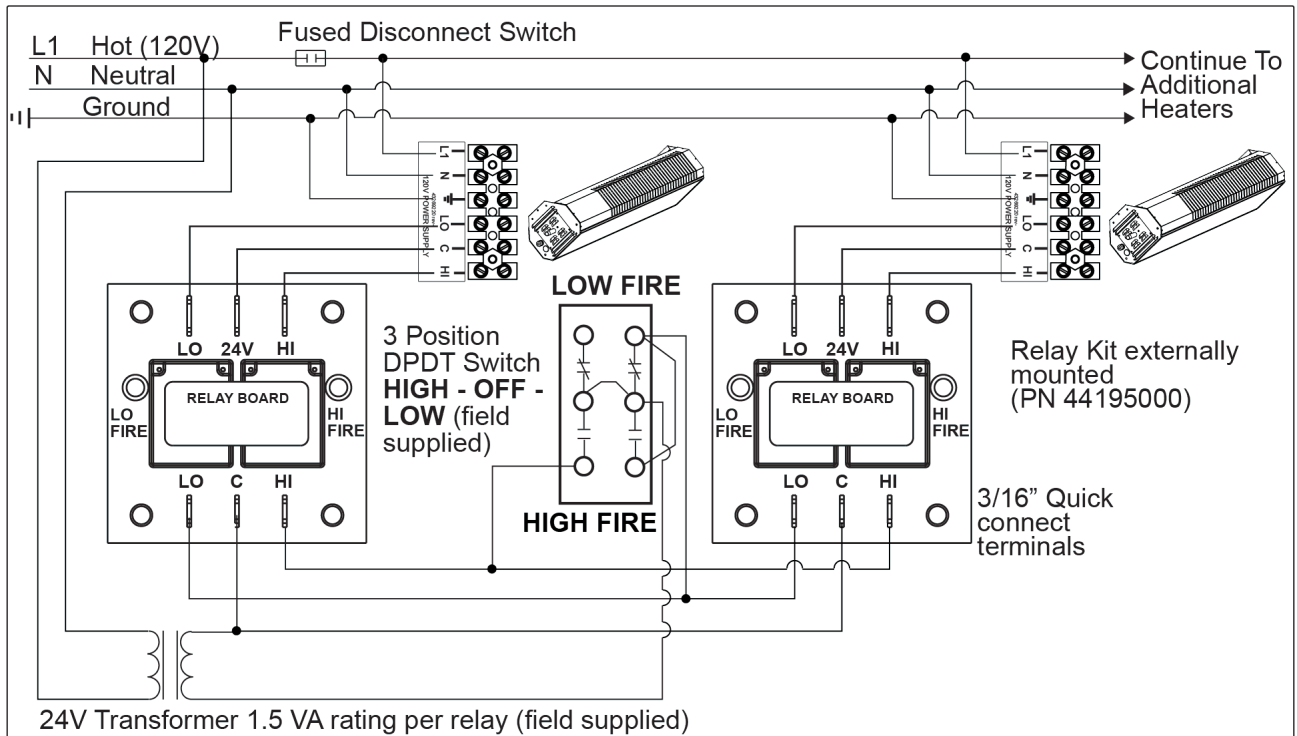

**C. LOW VOLTAGE (24V) THERMOSTAT CONNECTIONS - SINGLE HEATERS**

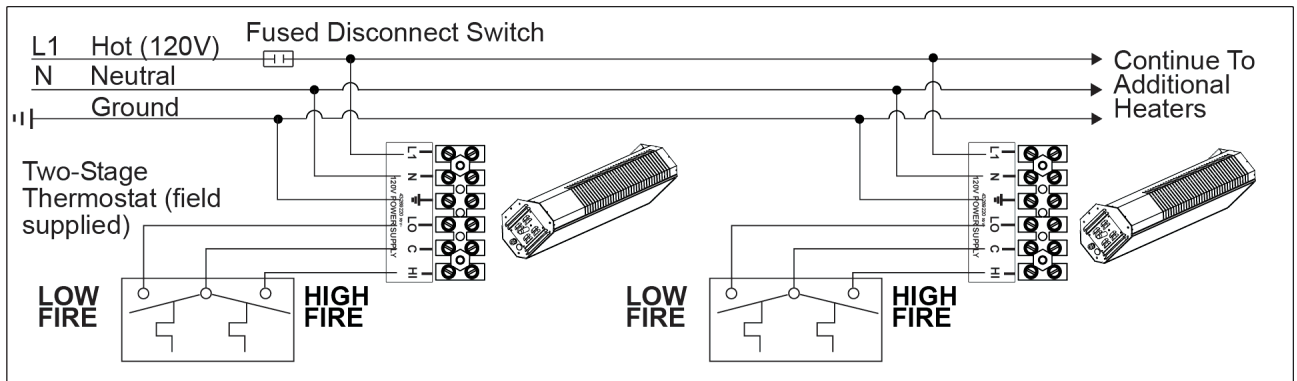

**D. LOW VOLTAGE (24V) THERMOSTAT CONNECTIONS - MULTIPLE HEATERS**

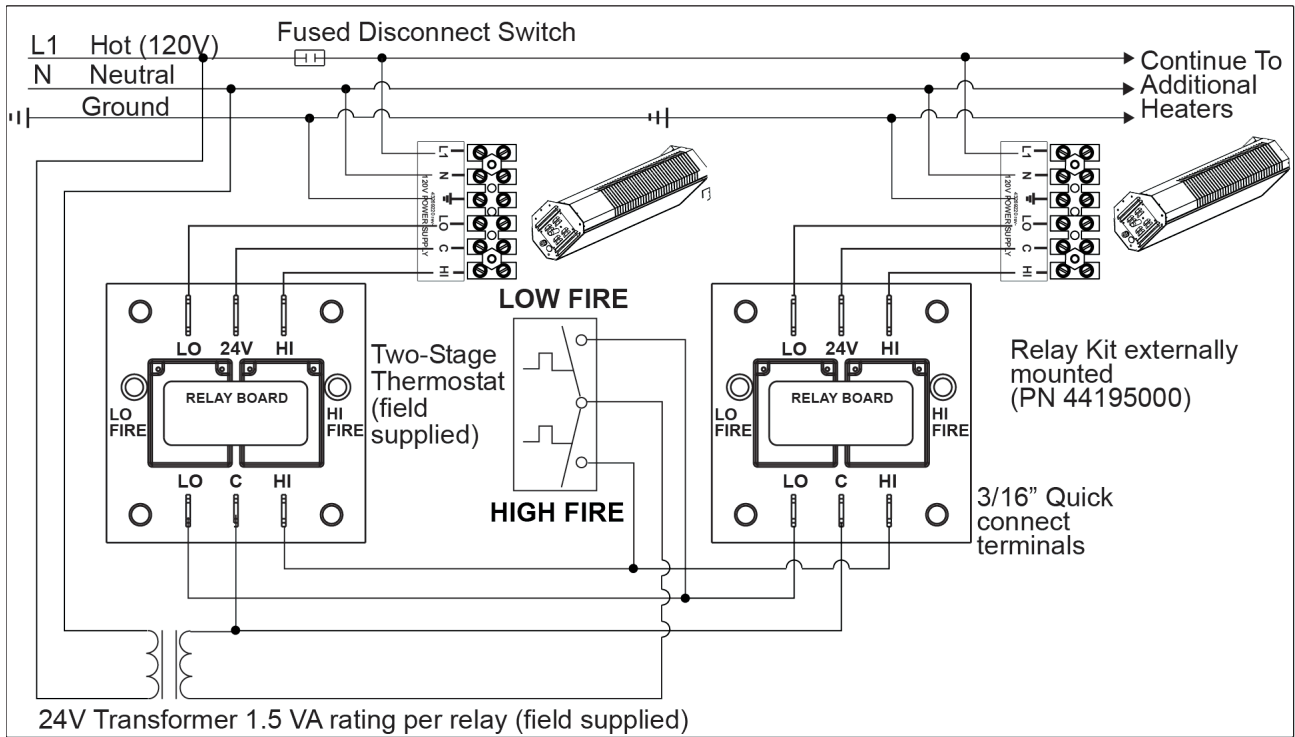

**16.3) FIELD CONNECTIONS AND WIRING DIAGRAMS - SINGLE STAGE 24V - MODELS WITHOUT REMOTE**

The figure below shows the internal connection to operate the heater turning on and off 24V power to the heater with a permanent live power supply.

Important: To operate the heater as single stage a jumper wire must be installed across the 24V LO and HI terminals as shown below. The heater will not operate with only 24V power to the HI terminal.

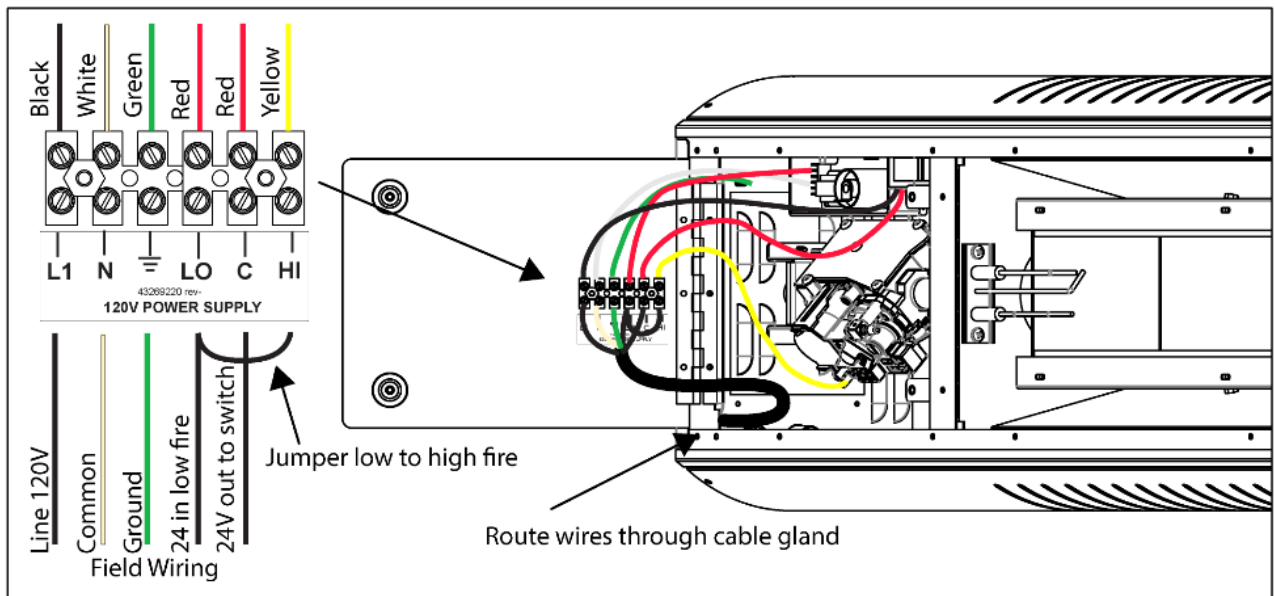

**A. LOW VOLTAGE (24V) ON / OFF SWITCH CONNECTION - SINGLE HEATERS**

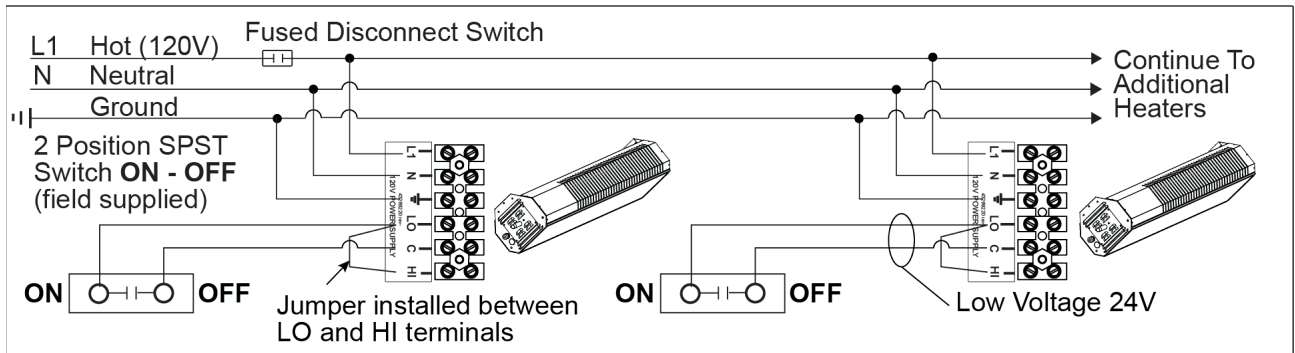

To operate the heater with an individual 24V thermostat use the same connections as above for the switch.

**16.4) FIELD CONNECTIONS AND WIRING DIAGRAMS - SINGLE STAGE 120V MODELS WITHOUT REMOTE**

The figure below shows the internal connection to operate the heater turning on and off 120V power to the heater. Important: To operate the heater as single stage with 120V all three wires from the LO, C and HI terminals must be connected.

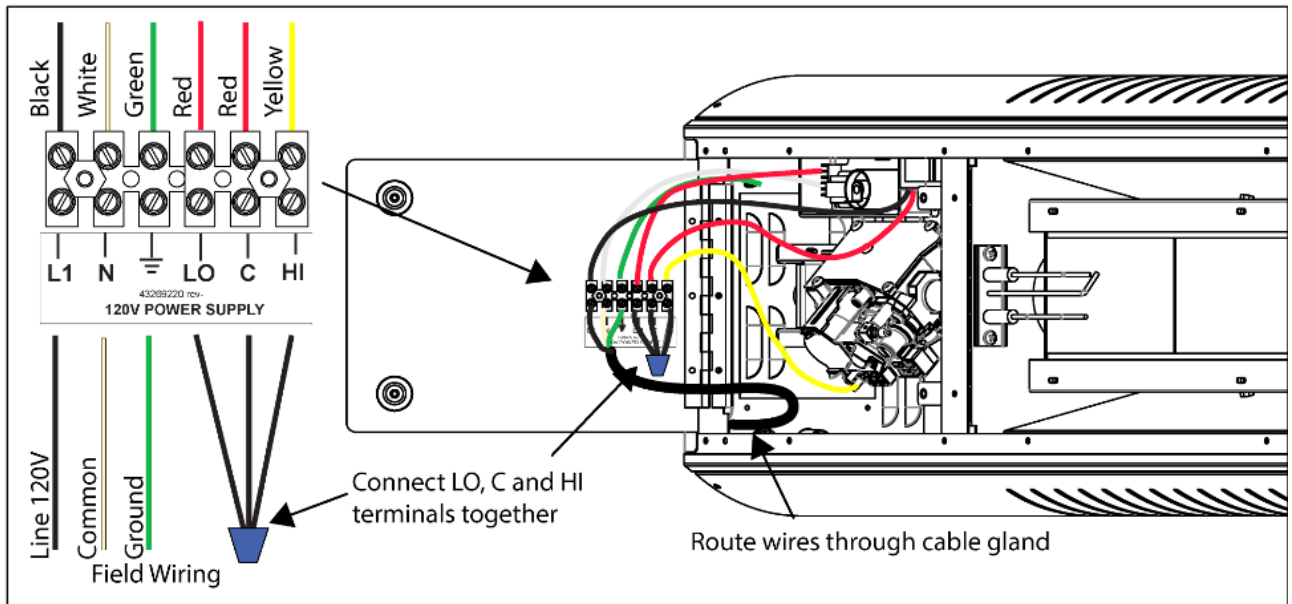

**A. LINE VOLTAGE (120V) ON / OFF SWITCH CONNECTION - SINGLE HEATER**

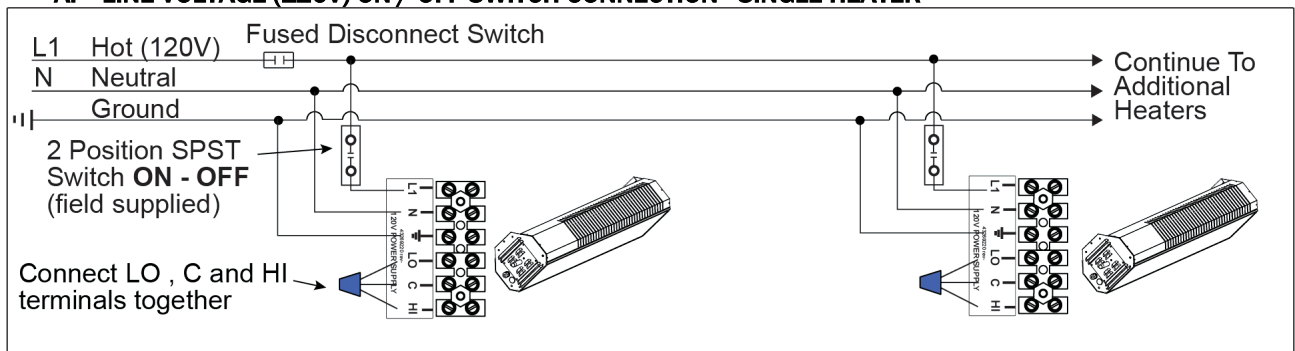

To operate the heater with an individual 120V thermostat use the same connections as above for the switch.

**B. LINE VOLTAGE (120V) ON / OFF SWITCH CONNECTION - MULTIPLE HEATERS**

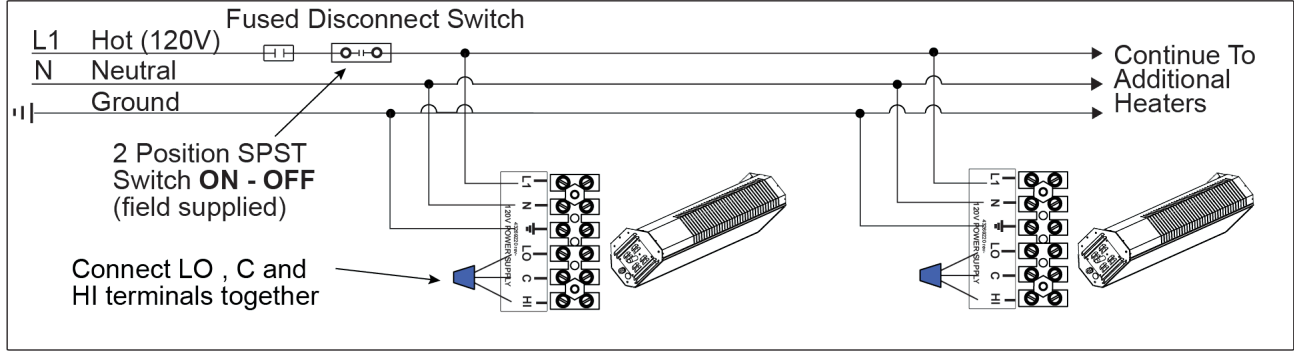

**16.5) INTERNAL CONNECTION WIRING DIAGRAM - MODELS WITH REMOTE**

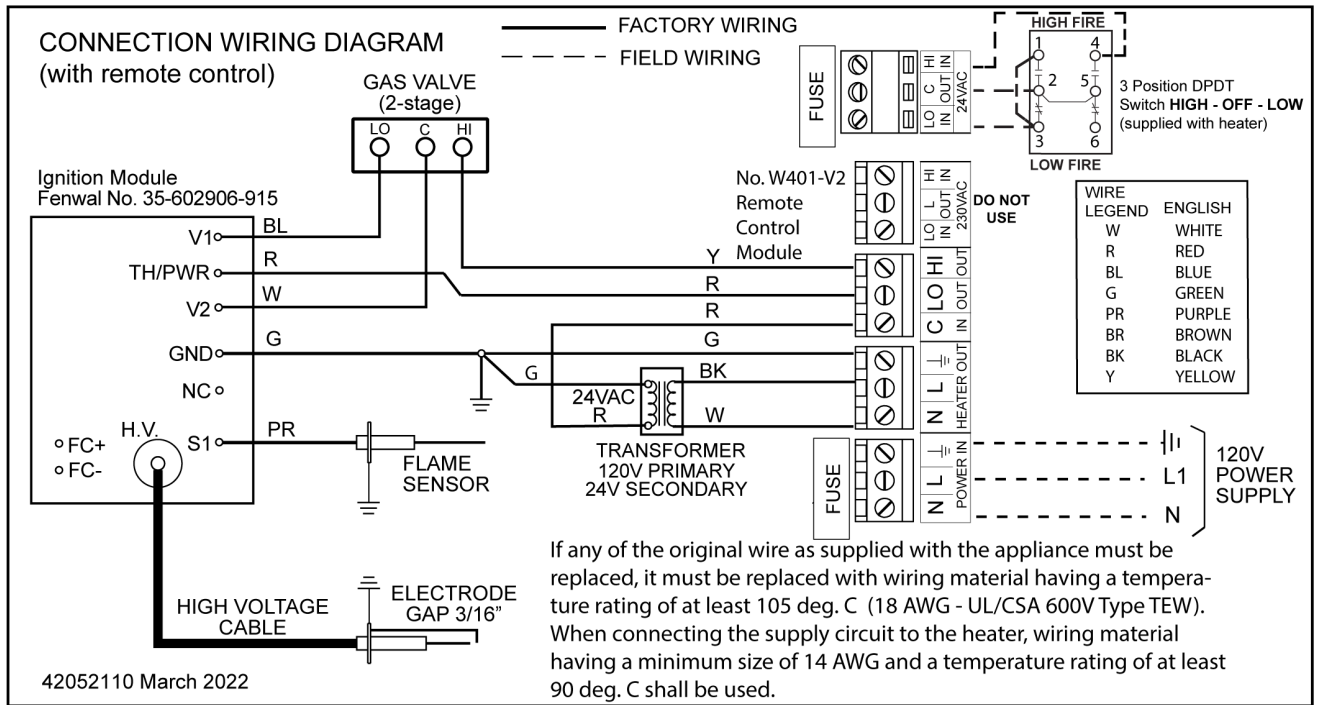

**16.6) FIELD CONNECTION AND WIRING DIAGRAM – 2 STAGE 24V MODELS WITH REMOTE**

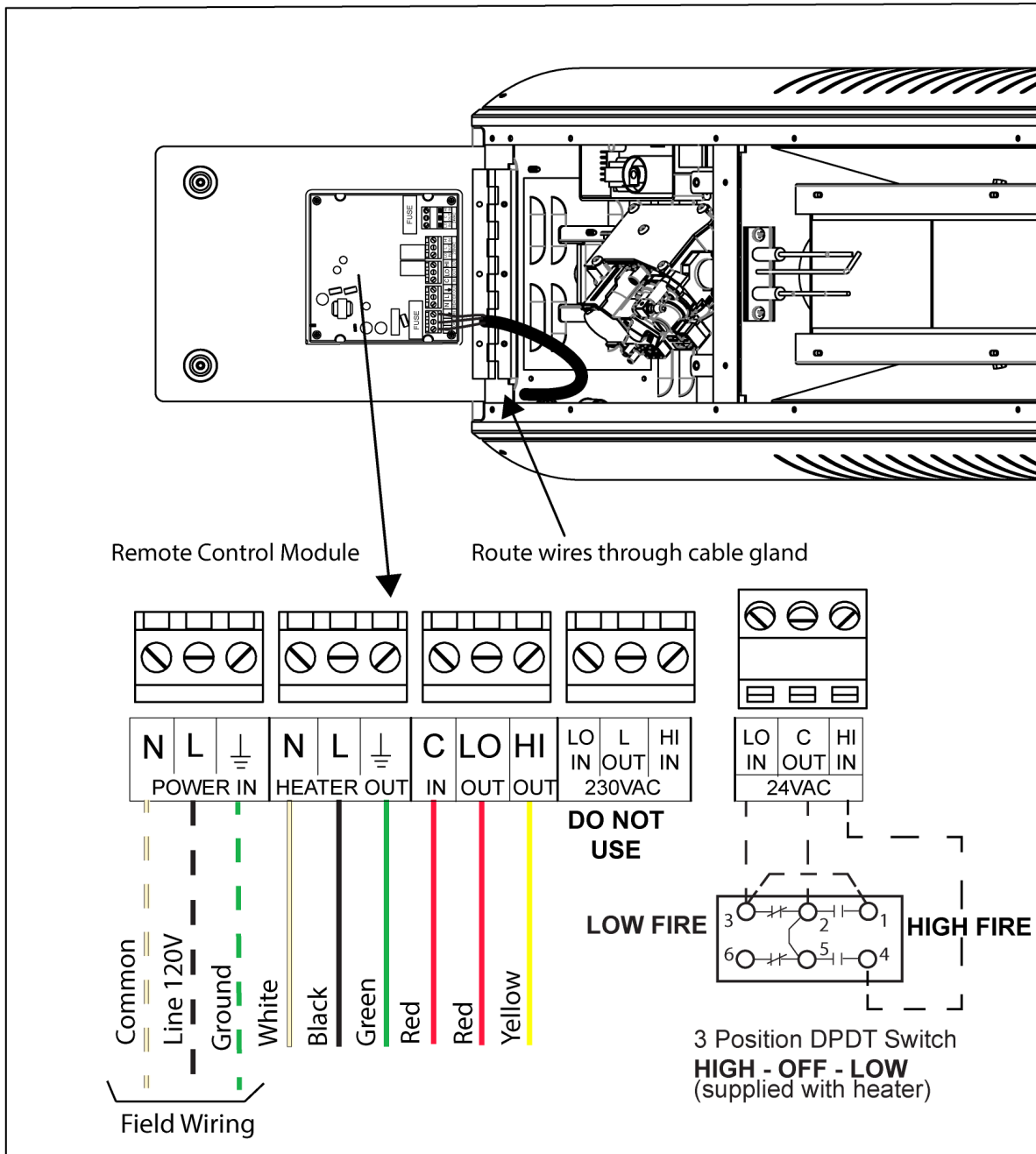

The figure above shows the field wiring connections to the heater remote control module.

The 3-position switch can be in a separate area from the heater. Maximum control wire length for the 3-position switch is 200 ft (61m). Minimum wire gauge is 18 gauge (1.0 mm<sup>2</sup>)

## 17.0) VENTILATION

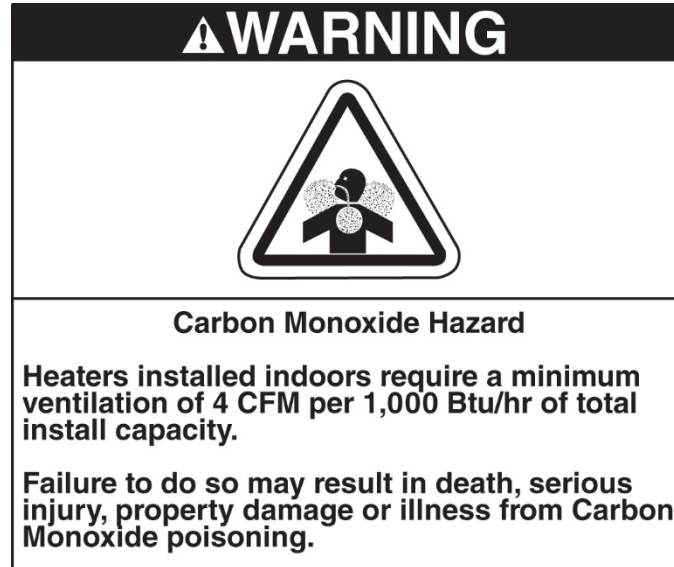

Where unvented infrared heaters are used, natural or mechanical means shall be provided to supply and exhaust at least 4 cfm per 1000 Btu/hr input of installed heaters.

Exhaust openings for removing flue products shall be above the level of the heaters.

This heater requires ventilation in the building to dilute the product of combustion and provide fresh air for efficient combustion. Power ventilation is recommended, and the minimum vent flow required is as follows:

RIHP35-WITHOUT REMOTE and W/REMOTE = 140 cfm

RIHP50-WITHOUT REMOTE and W/REMOTE = 204 cfm

The General Ventilation Rules outlined in ASHRAE GUIDE AND DATA BOOK should be observed when locating vents. Exhaust vents must be located at the highest point above and in the vicinity of the heaters and the inlet vents must be located below the level of the heaters. Inlet openings in the building should be well distributed high in the sidewalls and should direct incoming air upward to dilute products of combustion while preventing drafts at lower levels. Inlets are typically 1 to 3 sq. ft. Local codes may require that mechanical exhaust systems be interlocked with thermostats to function simultaneously.

## 18.0) LIGHTING AND SHUTDOWN INSTRUCTIONS

<b>⚠ WARNING</b>

<b>Electric Shock and Fire Hazard</b>
Disconnect power to the heater before servicing.
Do not operate unit if repairs are necessary. Do not operate unit showing any signs of burner malfunction. Call a professional for assistance
Failure to do so may result in death, serious injury or property damage

<b>⚠ WARNING</b>

<b>Cut Hazard</b>
Do not operate heater if ceramic glass appears to be cracked or broken.
Failure to do so may result in death, serious injury or property damage.

### Direct Burner Spark Ignition Modules.

1. Turn on the gas supply to the appliance.
2. Set any time switch or thermostats to demand heat.
3. Switch on the electrical supply to the appliance.
4. Following a 7 second pre-purge the burner should ignite after a further 10 seconds.
5. If the burner fails to light, or flame is not detected during the first trial for ignition (a period of 10 seconds) the gas valve is de-energized, and the control goes through an inter-purge delay of 15 seconds before another ignition attempt. The control will attempt two additional ignition trials before going into lockout.
6. If 'Lockout' occurs, switch off the electrical supply to the appliance, wait for 5 minutes before switching on the electrical supply to the appliance to repeat the ignition sequence.
7. If the appliance fails to ignite after a second sequence, switch off the electricity supply to the appliance and call the service engineer.
8. If gas failure occurs after successful ignition, the appliance will attempt one re-ignition before going to "Lockout" conditions.
9. To shut down the appliance for short periods of time, switch off the electrical supply to the appliance.
10. To shut down the appliance for longer periods of time switch off the electrical supply to the appliance and turn off the gas supply at the gas isolation valve.
11. If in "Lockout" condition the appliance will automatically attempt to re-ignite after 15 minutes.

## 18.1) HEATER OPERATION – MODELS WITH REMOTE

1. Remove the battery compartment cover by pressing down and sliding away from the remote.
2. Load both batteries (supplied) with the positive (+) and negative (-) side of the batteries matching the inside of the remote compartment.
3. Replace the cover.

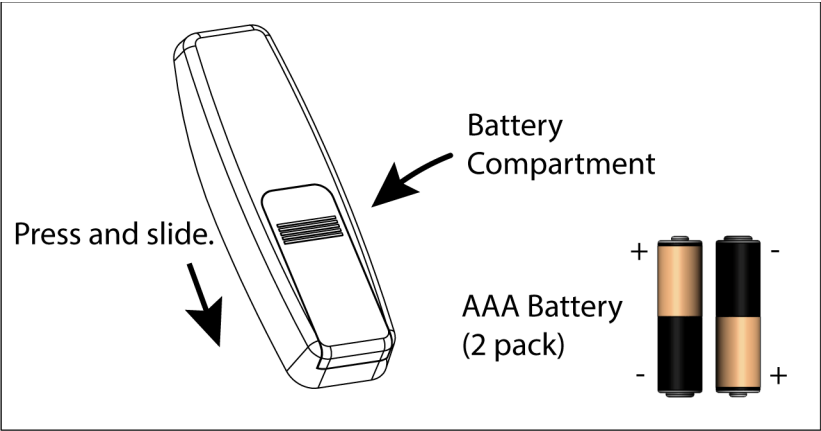

The 3-position switch is intended as a back up to the remote control. The operation of the switch is dominant over the remote control. The remote will only operate the heater when the 3-position switch is in the OFF (center) position. Multiple patio heaters can be controlled individually with the same remote.

An LED with various blinking sequences can be seen through the dark glass. The blinking sequence as indicated below show if the heater is in standby, operated via remote or operated via the 3-position switch.

To operate the heater with the remote control.

1. Make sure the 3-position switch is in the OFF (center) position.
2. Aim the remote toward the control portion of the heater as shown and press **ON**. Note: The maximum distance to operate the remote away from the heater should be approximately 20 ft. Longer distances might not give a good signal to operate the heater.
3. Pressing **LOW** will enable the heater to run on the lowest heat output (Low Fire).
4. Pressing **HIGH** will enable the heater to run on the highest heat output (High Fire).
5. Pressing **OFF** will turn the heater off.

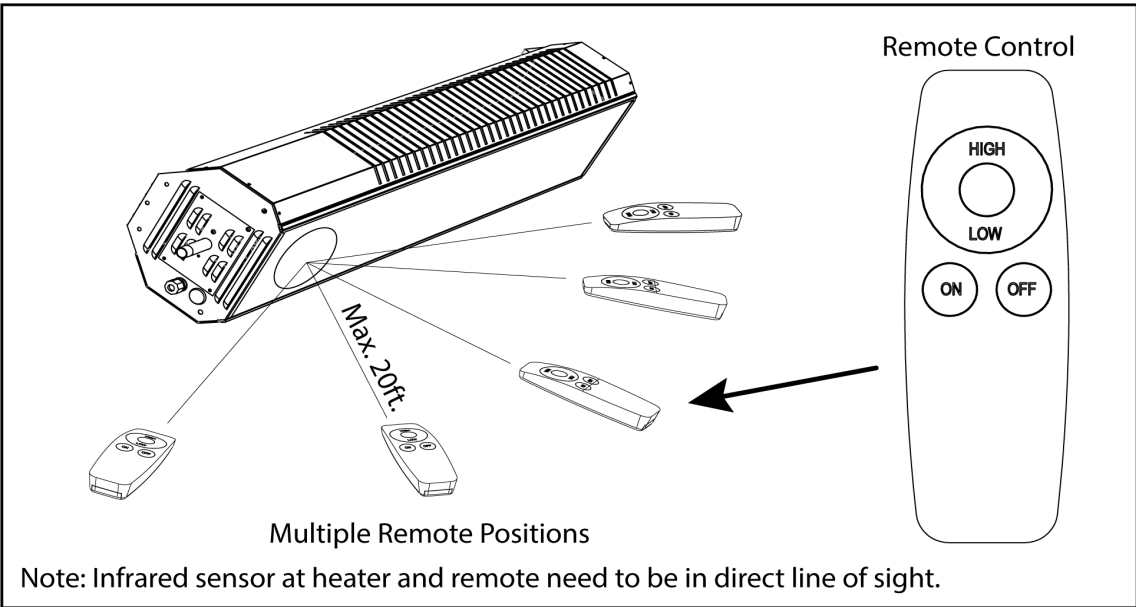

Using the 3-position switch:

Note: the remote will not operate the heater when the switch is in the high or low fire position.

1. Pushing the switch into the **LOW** will start the heater in Low fire.
2. Pushing the switch into the **HIGH** position will start the heater in High fire.
3. Pushing the switch into the **OFF** position will turn the heater **OFF**.

LED blinking sequence:

The LED is clearly visible behind the glass. It is located on the control side (gas and electrical supply) of the heater. The blinking sequence below identifies the operating mode of the heater.

Functions	Operation	LED blinking sequence		
		On time (secs)	Off time (secs)	Repetition
Stand By mode	Heater OFF	0.1	60	Continuous
Using Remote	Heater low Fire	5	5	Continuous
Using remote	Heater High Fire	1	5	Continuous
Using Switch	Heater low Fire	1	1	Continuous
Using Switch	Heater High Fire	5	1	Continuous
Internal board fault	Heater OFF	constant	N/A	N/A

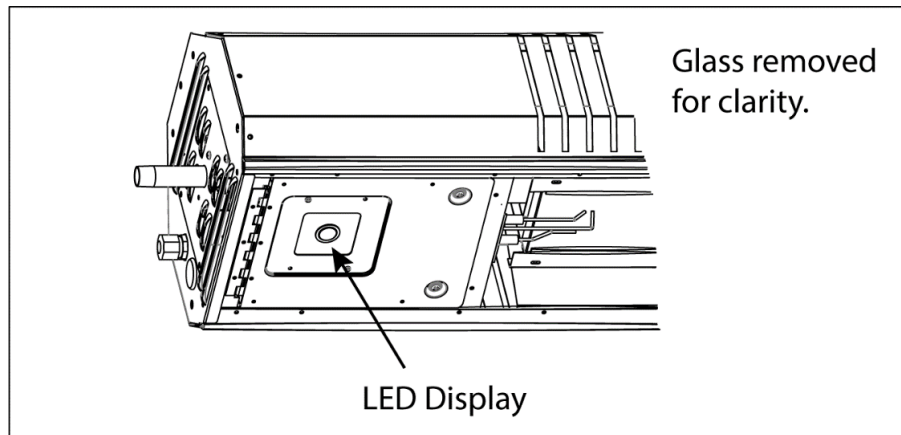

## 18.2) SEQUENCE OF OPERATION

Normal operation:

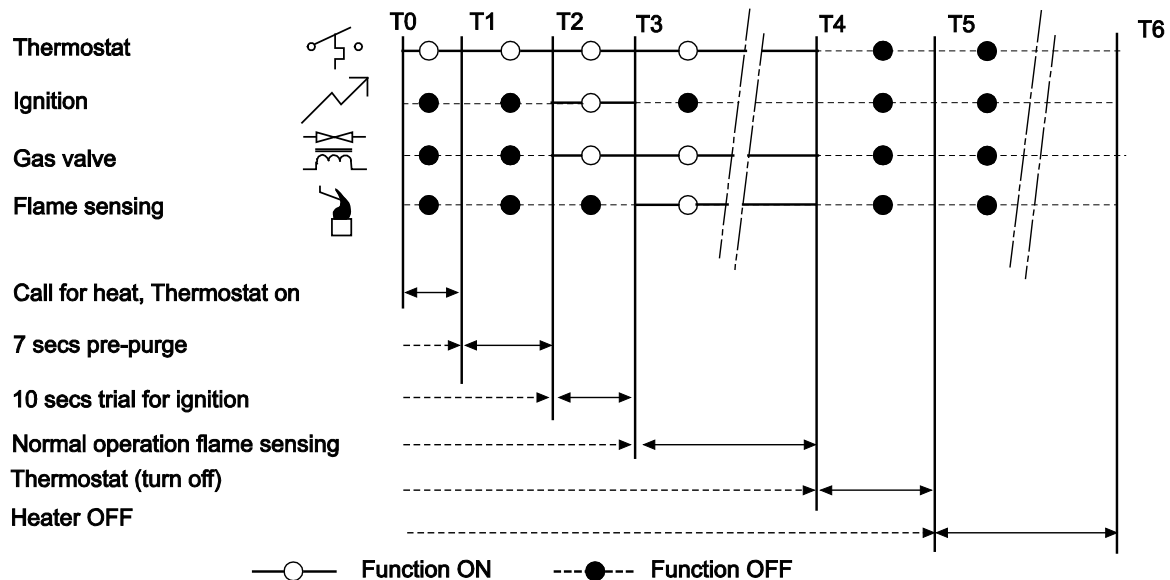

The chart below shows the sequence of operation for the normal operating cycle of the heater turned on and off by a remote thermostat.



If the burner fails to light, or flame is not detected during the first trial for ignition (a period of 10 seconds) the gas valve is de-energized, and the control goes through an inter-purge delay of 15 seconds before another ignition attempt. The control will attempt two additional ignition trials before going into lockout.

If 'Lockout' occurs, switch off the electrical supply to the appliance, wait for 10 seconds before switching on the electrical supply to the appliance to repeat the ignition sequence.

## 19.0) SERVICING AND ANNUAL MAINTENANCE

<b>⚠ WARNING</b>		
<b>Electric Shock Hazard</b> 	<b>Fire and Explosion Hazard</b> 	<b>Burn Hazard</b> 
<b>Disconnect electric before service.</b>  <b>Heater must be connected to a properly grounded electrical source.</b>	<b>Turn off gas supply to heater before service.</b>	<b>Allow heater to cool 30 minutes before service.</b>  <b>Glass and heater surfaces will still be hot after operation.</b>
<b>Failure to follow these instructions can result in death, serious injury or property damage.</b>		

<b>⚠ CAUTION</b>	
	<b>EQUIPMENT FAILURE HAZARD</b> Do not blow out heating elements with high pressure air. Do not cover panel with hot glass. Failure to do so may result in property damage.

This heater must be cleaned and serviced annually by a qualified contractor before the start of each heating season and at any time excessive accumulation of dust and dirt is observed. Maximum heating efficiency and clean combustion will be maintained by keeping the heater clean. Detailed instructions for component removal are given in Section 21.0) Replacing Parts.



After any maintenance and/or replacement of components the heater must be re-commissioned to ensure proper operation. After working on gas carrying components the appliance must be checked for gas leaks and pressure settings verified.

The contractor shall check the following during periodic maintenance.

- **Clearances to combustibles:** Check that clearances are being maintained. Make sure there are no flammable objects, liquids, or vapors near the heater. See also Section 4.0). Ensure heater mounting angle and heat shield installation position correspond to each other. See also Sections 12.1).
- **If the heater was installed using the outdoor Clearances to Combustibles:** Check that the area has not been closed in making it an indoor installation. If any changes have been made, then the clearances and ventilation requirements for Indoor installations apply.
- **Heat Shield:** The Heat Shield must be kept clean, at a minimum blow off the Heat Shield and wipe down with a damp cloth. Ensure Heat Shield is properly attached to heater. See Section 13.0). Review that the heat shield installation location matches the heater mounting angle.
- **Heater ventilation openings:** Make sure no foreign material has collected inside the heater through the ventilation openings. Remove any foreign materials.
- **Venting System:** Ensure heater has adequate ventilation. See also Section 17.0).
- **Gas lines:** Make sure that the gas lines are not leaking. Check the gas connection to the heater for any signs of damage, fatigue, or corrosion. If there are any signs of damage to the gas connection or leaks found in the gas piping, immediately stop using the heater and turn off the gas until the gas pipe and connections have been repaired or replaced. Check that the gas lines are not bearing the weight of the heater. See also Section 15.0)
- **Heater:** To extend the longevity of the heater it must be suspended level. See also Section 12.0).

- **Electrode condition:** Visually check that the electrode gap is maintained at 5mm (0.199”) and that the tips of the flame sensor and spark electrode are free from deposits. Clean off any deposits. Check that the electrode ceramic is free from cracks. See Section 21.2)
- **Suspension system:** Check that the suspension system is holding the heater level. Make sure that the heater is hanging securely, look for any evidence where the heater may have been hit accidentally and tighten any loose hanging points. Check that S hooks are closed. Check that there is no evidence of wear on the chain at the connection to the heater and at the ceiling.
- **Main Burner and Orifice:** Check the Main burner and orifice; remove any dirt or debris including spider webs.
- **Foreign Objects:** Check and remove any foreign objects that are loGGE35d between the heat shield and the heater.
- **Ceramic Glass:** Clean the glass from the inside and outside using a damp cloth. See also Section 21.1) for safe removal of glass. To remove stains on the glass surface, use a common household glass cooktop cleaner such as made by “Weiman” or “Cerama Bryte”.
- **Burner Assembly:** The burner assembly is not serviceable. The metal back may be cleaned with a damp cloth, the ceramic and gaskets must not be disturbed.
- **IMPORTANT:** DO NOT DIRECT AN AIR LINE AT THE CERAMIC PLAQUE SURFACE AS IT MAY DAMAGE THE CERAMIC TILES OR DISLODGE THE HIGH TEMPERATURE GASKET MATERIAL FROM AROUND THE TILES.
- **Safety Labels:** Replace safety and all other labels if they are no longer visible. See section 23.0) for replacements.
- **Wall Tag:** Ensure a wall tag has been placed near the heater’s thermostat or in a conspicuous area near the heater. Review the information for accuracy, replace if the information is no longer visible.
- **Heater Outside surfaces:** To clean the heaters brushed stainless steel outside surfaces a stainless-steel cleaner such as made by “Brasso” can be used. Note: The “tea colored” surface areas due to heat can be cleaned of contaminants but the “tea color” cannot be removed.

## 20.0) TROUBLE SHOOTING

<b>⚠ WARNING</b>		
<b>Electric Shock Hazard</b> 	<b>Fire and Explosion Hazard</b> 	<b>Burn Hazard</b> 
<b>Disconnect electric before service.</b>  <b>Heater must be connected to a properly grounded electrical source.</b>	<b>Turn off gas supply to heater before service.</b>	<b>Allow heater to cool 30 minutes before service.</b>  <b>Glass and heater surfaces will still be hot after operation.</b>
<b>Failure to follow these instructions can result in death, serious injury or property damage.</b>		

## 20.1) TROUBLE SHOOTING – MODELS WITHOUT REMOTE

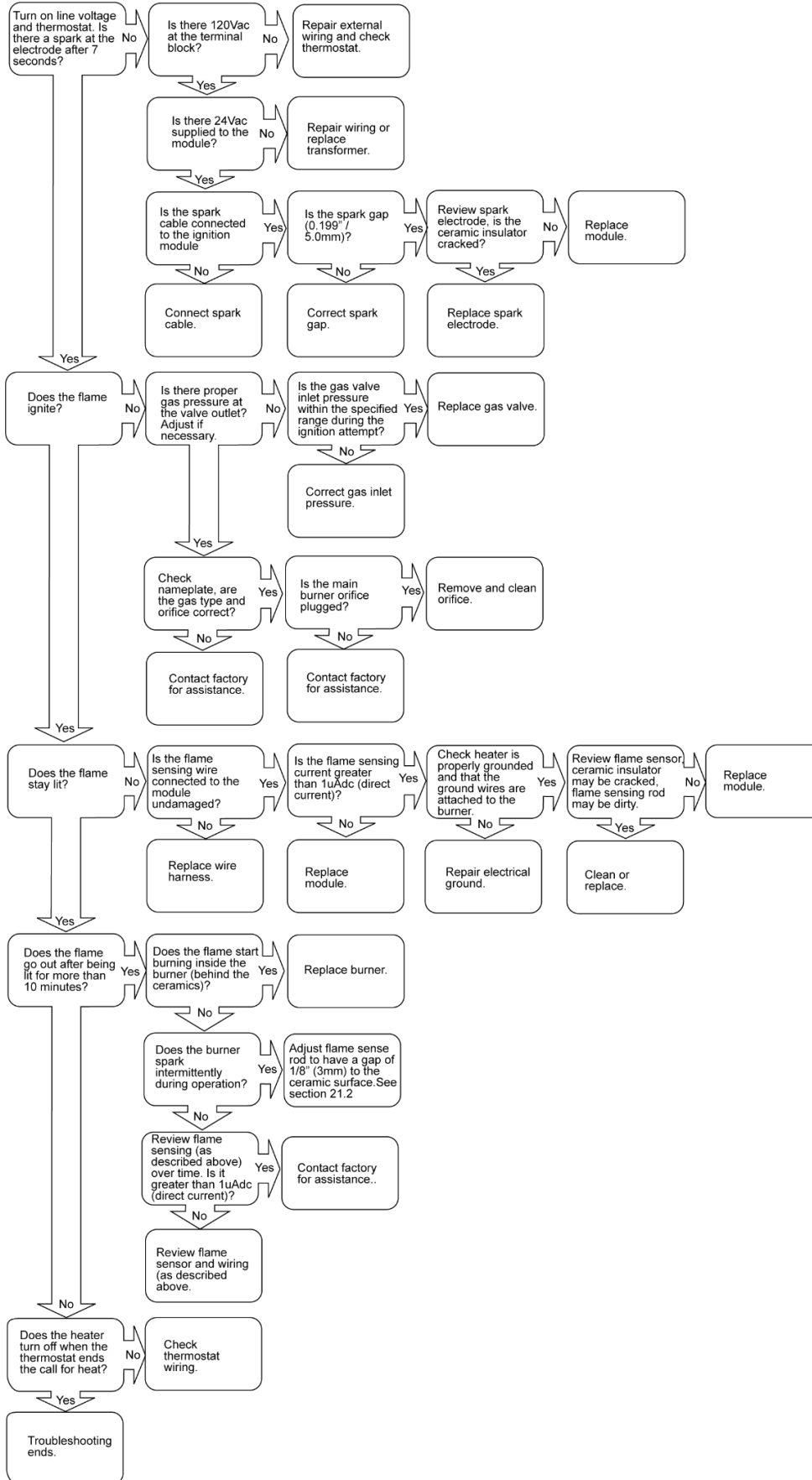

## 20.2) TROUBLE SHOOTING – MODELS WITH REMOTE

Turn on line voltage to heater.

Using remote:

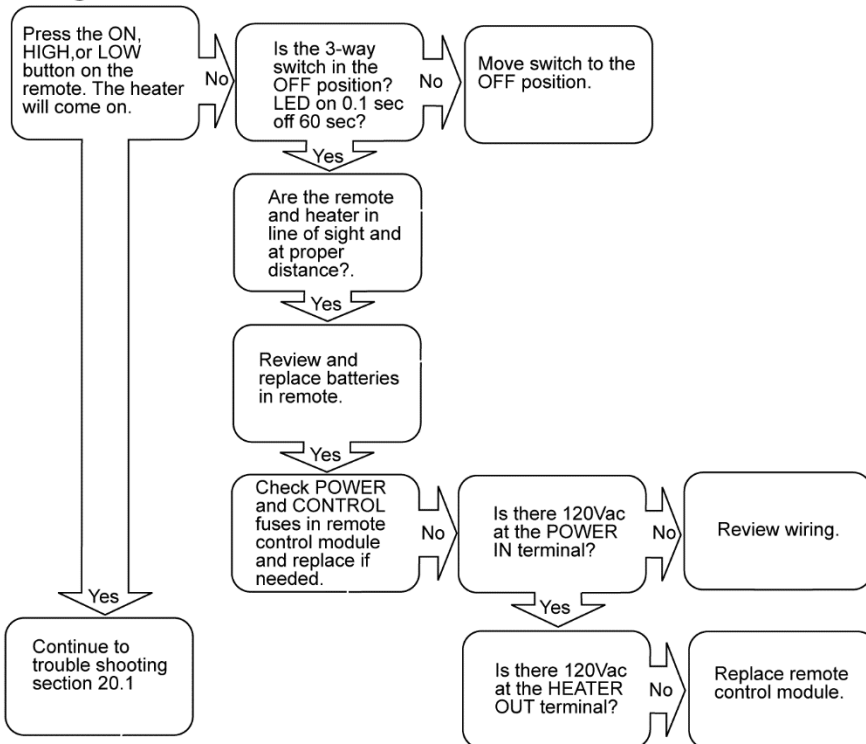

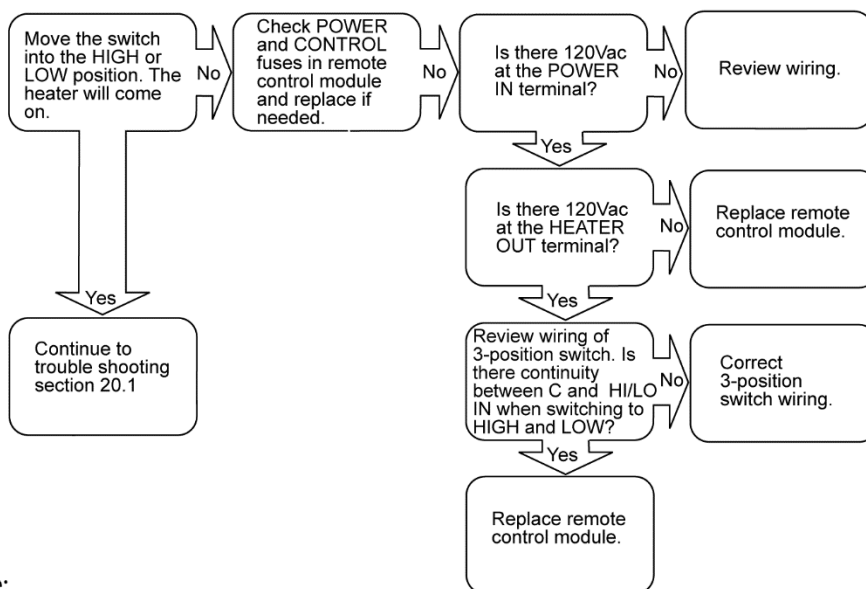

Using 3-way position switch:



Note:

- a) When the patio heater is switched on in the LOW fire mode the heater is forced into high fire for 2 minutes to allow the heater to warm up.
- b) Heater turns off after 2 minute operation, heater LOW fire LED blinking sequence can be seen (activated via remote or 3-position switch). Reverse center terminal LO OUT and HI OUT wires.

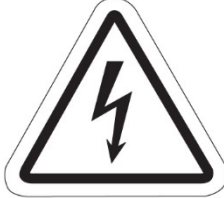
## 21.0) REPLACING PARTS

<b>⚠ WARNING</b>		
<b>Electric Shock Hazard</b> 	<b>Fire and Explosion Hazard</b> 	<b>Burn Hazard</b> 
<b>Disconnect electric before service.</b>  <b>Heater must be connected to a properly grounded electrical source.</b>	<b>Turn off gas supply to heater before service.</b>	<b>Allow heater to cool 30 minutes before service.</b>  <b>Glass and heater surfaces will still be hot after operation.</b>
<b>Failure to follow these instructions can result in death, serious injury or property damage.</b>		

## 21.1) REMOVAL OF GLASS PANEL

<b>⚠ WARNING</b>

<b>Burn Hazard</b>  <b>Hot surfaces! DO NOT remove glass while heater is in operation.</b>  <b>Allow heater to cool for at least 10 minutes before touching any surfaces.</b>  <b>Failure to do so may result in serious injury.</b>

1. Remove the glass retainer 1.
2. Carefully slide the glass panel 2 from the retainer rails and away from heater. Access to the gas control valve and ignition module can now be made by loosening the screws from the access panel assembly.
3. Clean the glass with a glass cleaning solvent. Inspect for any cracks.
4. Inserting the glass:
  - 4.1. The side of the glass where the logo emblem is attached must be slid in first for the logo emblem's final position to be at the control side of the heater.
  - 4.2. Slide the glass into the "Glass Retainer Rails". The glass must be held parallel to the Glass Retainer Rails during assembly. The glass will slide in easy with ample clearance. Slide the glass until it is positioned under the Glass Retainer at the heaters control enclosure side. At this point the glass will be flush with the heater at the insertion point.

Note: If the ceramic glass does not slide in easily review position of ceramic glass to glass retainers and adjust if needed. Do not force the ceramic glass into the glass retainers!

- Reinstall the Glass Access Retainer 1 removed in 1 with the two (2) sheet metal screws.

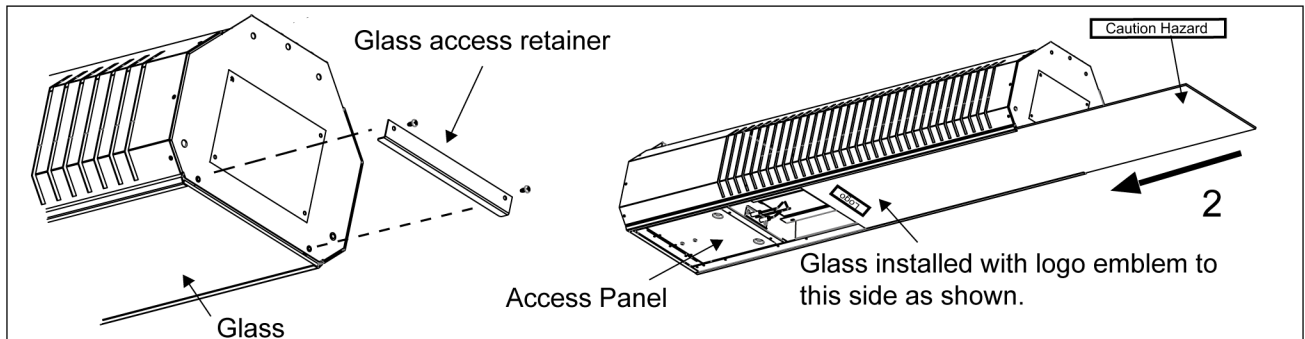

## 21.2) REMOVAL OF SPARK ELECTRODE/FLAME SENSOR

- Remove the glass panel as shown in Section 21.1). Open the access panel assembly by loosening the screws.
- Disconnect the ignition cable and flame sensor wires (not shown) from the spark electrode/flame sensor.
- Remove the screws holding the assembly and slide the spark electrode/flame sensor away from the heater.
- Inspect the ceramic portion of the electrode/flame sensors for any cracks. Remove any foreign matter from the electrode tips and check that the spark gap is .199" (5mm). If the electrode/flame sensor rods are badly oxidized, replace the electrode/flame sensor in the reverse order. **Note: When installed, the flame sensor rod must have a gap of 1/8" (3mm) to the ceramic surface.**

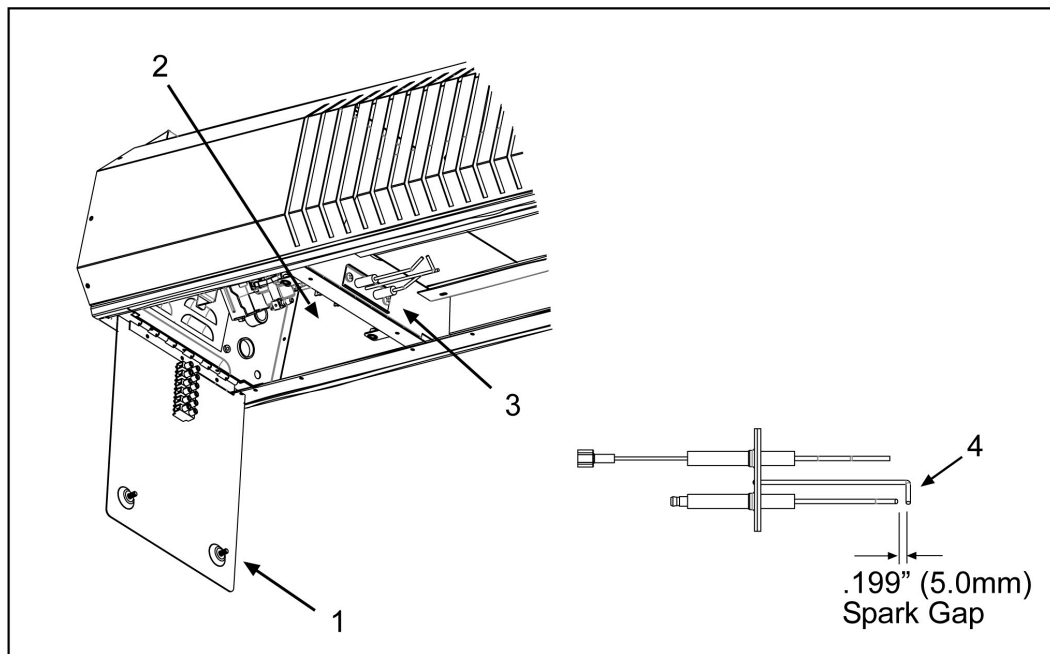

## 21.3) REMOVAL OF MAIN BURNER ORIFICE (INJECTOR)

- Open the access panel assembly as shown in Section 21.2). **Note: This is removed from the illustration for clarity.** Unscrew the main burner orifice from the gas valve manifold using a 1/2" (12.7mm) end wrench.
- Inspect the orifice and clean as necessary with a soft bristle brush.

**DO NOT DAMAGE ORIFICE OPENING BY USE OF SOLID OBJECTS.**

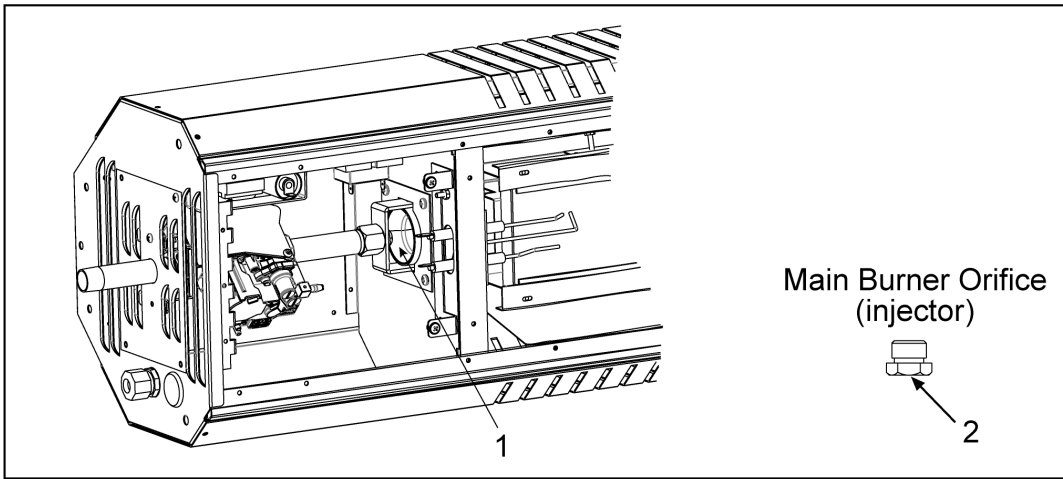

## 21.4) REMOVAL OF GAS VALVE

1. Open the access panel assembly as shown in Section 21.2). **Note: This is removed from the illustration for clarity.** Loosen the panel nut 1 using a  $\frac{3}{4}$ " (19mm) end wrench and remove from the gas valve manifold.
2. Disconnect the wires to the gas valve.
3. Remove the (4) screws from the louvered valve holder plate 3.
4. Rotate the gas valve/ignition control module assembly and slide away from the heater.

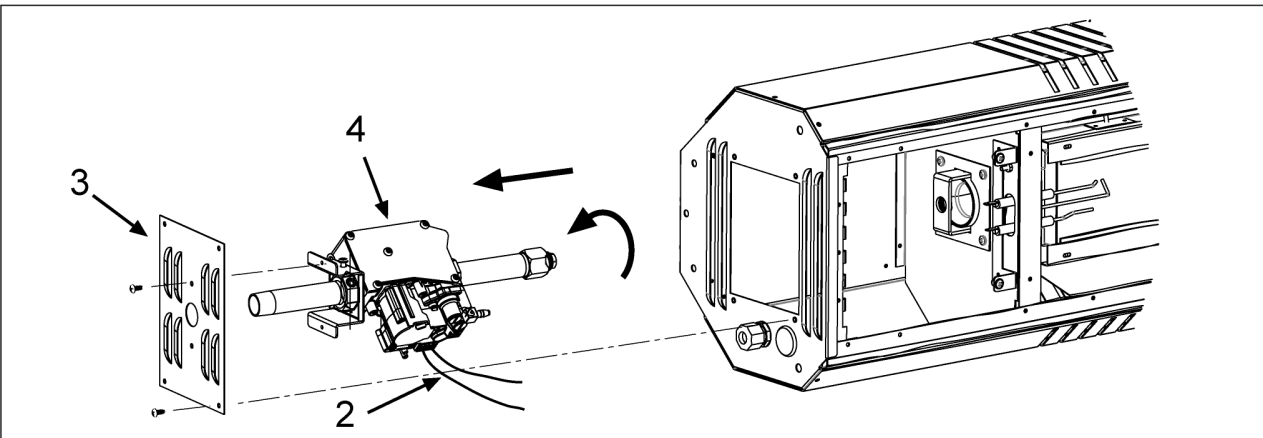
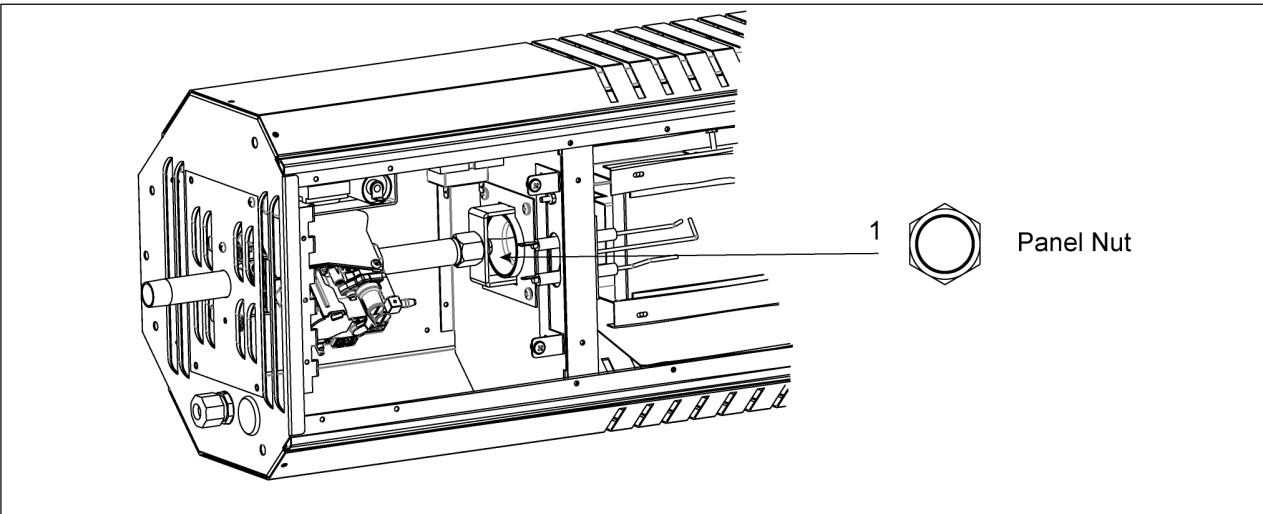

## 21.5) REMOVAL OF IGNITION CONTROL MODULE AND TRANSFORMER

1. Open the access panel assembly as shown in Section 21.2) **Note: This is removed from the illustration for clarity.** Disconnect the ignition cable from the ignition control module.
2. Disconnect the 5-way Molex electrical wire harness connector (not shown) from the module. Remove the screws 2 holding the ignition control module and remove it from the heater.
3. Disconnect the transformer lead wires. Remove the screws 3 holding the transformer and remove it from the heater.

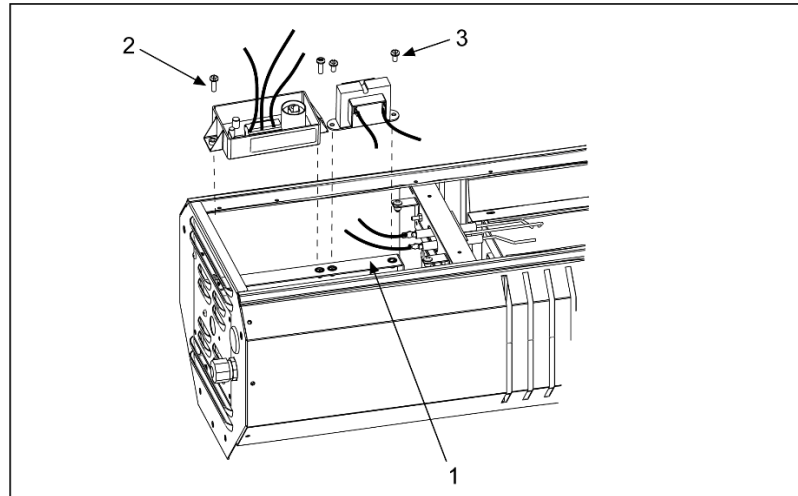

## 21.6) REMOVAL OF MAIN BURNER/EMITTER ASSEMBLY

- A. Remove the ceramic glass and open the access panel assembly as shown in Section 21.1)
  - B. Remove the gas valve as shown in Section 21.4)
1. Remove burner access panel 2 from the opposite side of the heater.
  2. Remove the (2) locknuts 3 holding the main burner.
  3. Slide the burner slightly toward the front of the heater.
  4. Rotate the burner away from the heater.
  5. Slide the burner out from the heater. Replace the burner in reverse order.

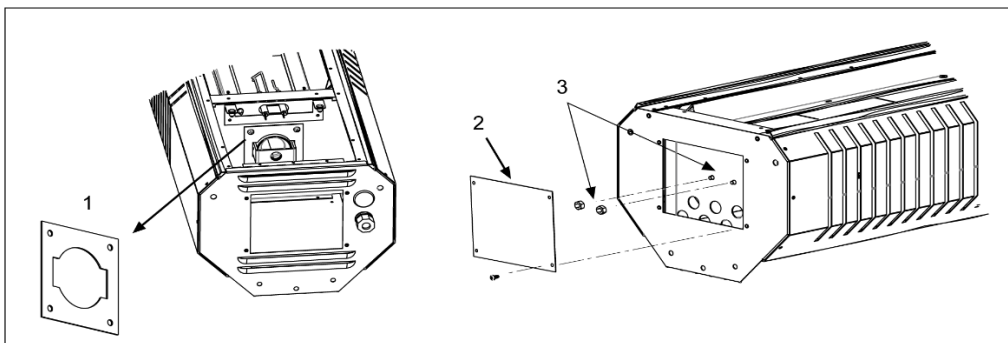

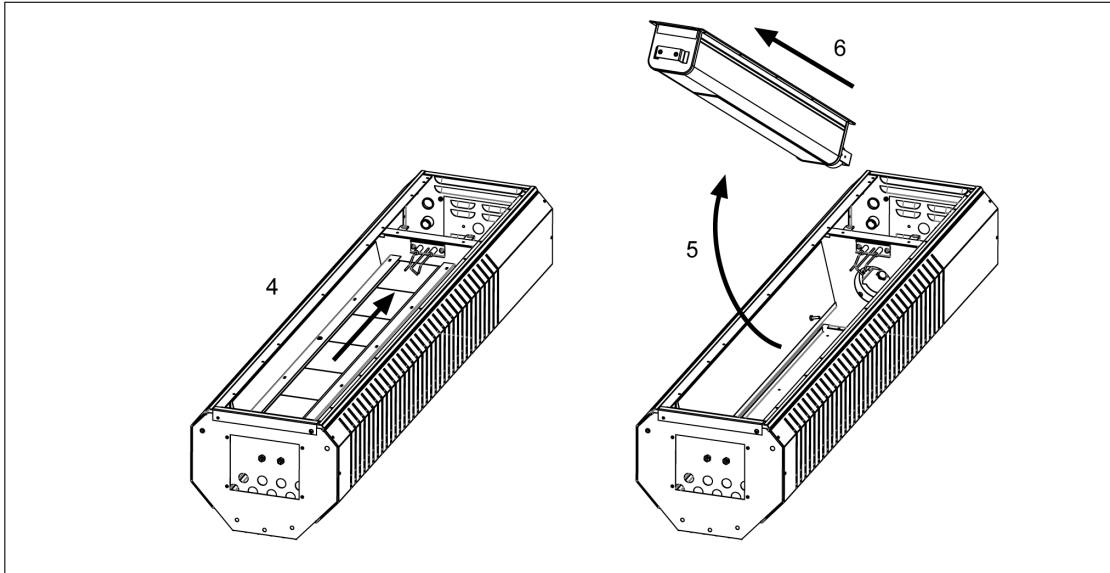

## 21.7) REPLACING PARTS – MODELS WITH REMOTE

The remote control is not serviceable. If the remote does not operate the heater the batteries may be empty and need to be replaced with AAA BATTERY 2-PACK.

The 3-position is not serviceable. Review wire connections for proper continuity if needed.

The remote-control module is not serviceable. If the heater does not operate the fuse may have blown. Remove fuses, check for continuity, and replace with FUSE, 1 AMP 250V, 125V if open circuit.

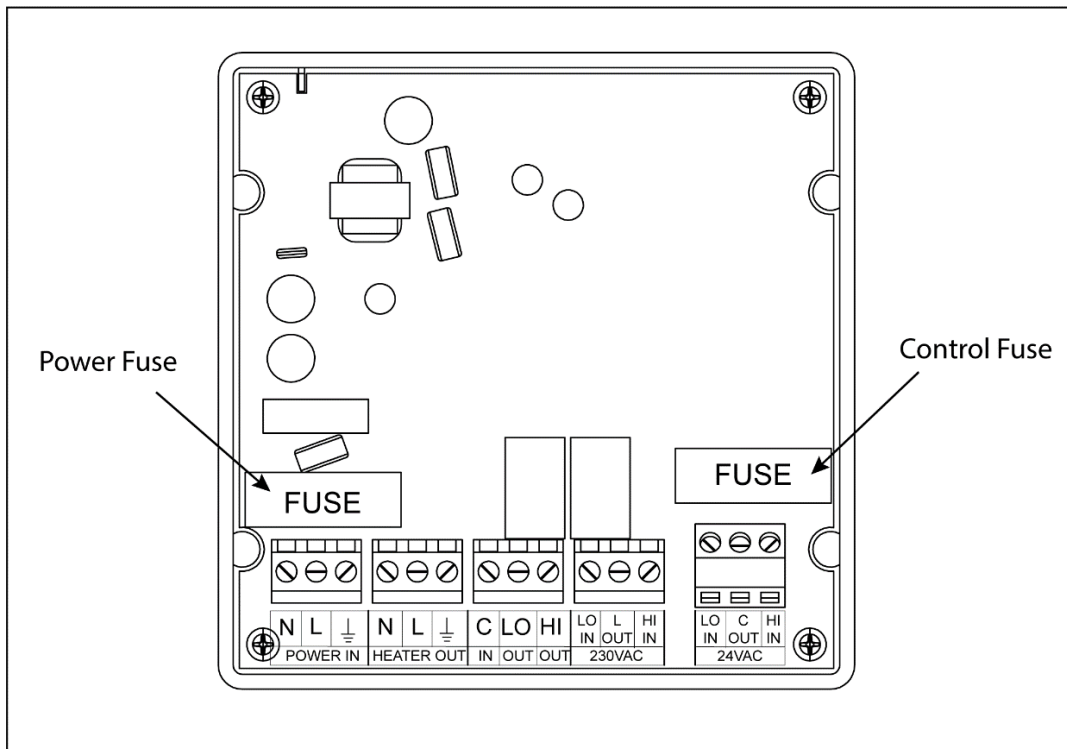

## NOTES

## NOTES

## NOTES

## INSTALLATION RECORD (TO BE COMPLETED BY INSTALLER)

For service or repair, contact the Installer. For additional assistance, contact the Distributor. For more information, contact your Factory Representative.

Model	Serial No.	Date of Installation	Notes
	Installer	Distributor	
Name			
Company			
Address			
Phone No.			

For more information on Reznor HVAC products:

- Contact your local Reznor representative at 1-800-695-1901
- Refer to the technical specifications, manuals, and consumer materials found at [www.reznorhvac.com](http://www.reznorhvac.com)

