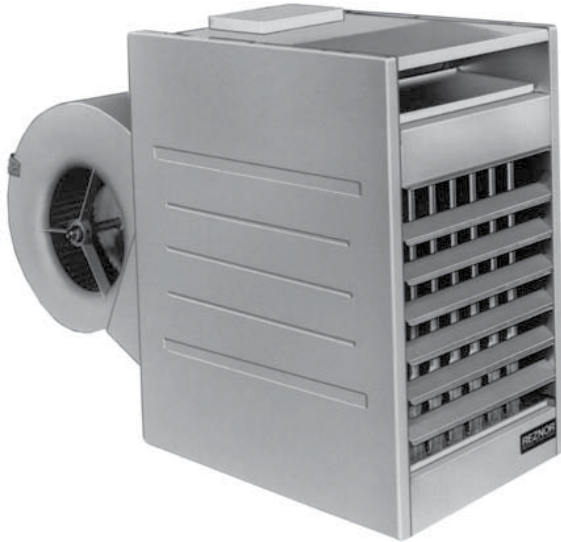


Installation / Operation / Maintenance

Applies to: **Model F** and **Model B**
**Gas-Fired, Gravity-Vented
Unit Heaters**



Model B



Model F

WARNING:

FIRE OR EXPLOSION HAZARD

Failure to follow safety warnings exactly could result in serious injury, death, or property damage.

Be sure to read and understand the installation, operation, and service instructions in this manual.

Improper installation, adjustment, alteration, service, or maintenance can cause serious injury, death, or property damage.

- Do not store or use gasoline or other flammable vapors and liquids in the vicinity of this or any other appliance.
- **WHAT TO DO IF YOU SMELL GAS**
 - Do not try to light any appliance.
 - Do not touch any electrical switch; do not use any phone in your building.
 - Leave the building immediately.
 - Immediately call your gas supplier from a phone remote from the building. Follow the gas supplier's instructions.
 - If you cannot reach your gas supplier, call the fire department.
- Installation and service must be performed by a qualified installer, service agency, or the gas supplier.

TABLE OF CONTENTS

| | |
|---|---|
| <p>1. General 2-3</p> <p> 1.1 Hazard Labels and Notices 2</p> <p> 1.2 General Installation Information..... 3</p> <p> 1.3 Warranty 3</p> <p> 1.4 Installation Codes 3</p> <p>2. Unit Heater Location..... 3-4</p> <p> 2.1 General Recommendations 3</p> <p> 2.2 Combustion Air Requirements for a Heater Located in a Confined Space 4</p> <p>3. Uncrating and Preparation..... 4-8</p> <p> 3.1 Uncrating and Inspecting..... 4</p> <p> 3.2 Preparing the Heater for Installation..... 4</p> <p>4. Clearances and Dimensions 8-11</p> <p> 4.1 Clearances..... 8</p> <p> 4.2 Dimensions 9</p> <p>5. Hanging the Heater..... 11-13</p> <p> 5.1 Weights11</p> <p> 5.2 Lifting and Suspending11</p> <p>6. Mechanical 13-23</p> <p> 6.1 Gas Piping and Pressures 13</p> <p> 6.2 Venting..... 16</p> <p> 6.3 Inlet Air - Blower Model B 19</p> <p> 6.4 Unit Discharge 20</p> <p> 6.5 Fan, Blower, and Drive 22</p> | <p>7. Electrical Supply and Wiring 23-29</p> <p> 7.1 General 23</p> <p> 7.2 Supply Voltage and Wiring..... 23</p> <p> 7.3 Control Wiring 24</p> <p> 7.4 Typical Wiring Diagrams 26</p> <p>8. Controls 30-31</p> <p> 8.1 Fan Control..... 30</p> <p> 8.2 Blocked Vent Switch..... 30</p> <p> 8.3 Limit Control 30</p> <p> 8.4 Gas Valve..... 30</p> <p> 8.5 Pilot and Ignition Systems..... 31</p> <p> 8.6 Burner Air Adjustment..... 31</p> <p>9. Commissioning and Start-Up 32</p> <p> 9.1 Check the installation prior to start-up: 32</p> <p> 9.2 Start-Up 32</p> <p> 9.3 Check installation after start-up:..... 32</p> <p>10. Maintenance and Service..... 33-38</p> <p> 10.1 Maintenance Schedule 33</p> <p> 10.2 Maintenance Procedures 33</p> <p> 10.3 Troubleshooting..... 38</p> <p>INDEX..... 39</p> <p>INSTALLATION RECORD 40</p> |
|---|---|

1. General

1.1 Hazard Labels and Notices

There are warning labels on the unit and throughout this manual. For your safety, read the definitions below and comply with all boxes labeled CAUTION, WARNING, and DANGER during installation, operation, maintenance, and service of this heater.

Definitions of Hazard Intensity Levels in this Manual

HAZARD INTENSITY LEVELS

- 1. DANGER:** Failure to comply will result in severe personal injury or death and/or property damage.
- 2. WARNING:** Failure to comply could result in severe personal injury or death and/or property damage.
- 3. CAUTION:** Failure to comply could result in minor personal injury and/or property

WARNING: Gas-fired appliances are not designed for use in hazardous atmospheres containing flammable vapors or combustible dust, in atmospheres containing chlorinated or halogenated hydrocarbons, or in applications with airborne silicone substances. See Hazard Levels, above.

1.2 General Installation Information

Installation should be done by a qualified agency in accordance with the instructions in this manual and in compliance with all codes and requirements of authorities having jurisdiction. The instructions in this manual apply only to Model F and Model B unit heaters.

1.3 Warranty

Refer to the limited warranty form in the "Literature Bag"

WARRANTY: Warranty is void if.....

- a. **Unit Heaters are used in atmospheres containing flammable vapors or atmospheres containing chlorinated or halogenated hydrocarbons or airborne silicone substances.**
 - b. **Wiring is not in accordance with the diagram furnished with the heater.**
 - c. **Unit is installed without proper clearances to combustible materials or located in a confined space without proper ventilation and air for combustion. (See Paragraphs 2.2 and 4.1.)**
 - d. **Fan-type unit heater is connected to a duct system.**
-

1.4 Installation Codes

The gas-fired unit heaters covered in this manual are design-certified by the Canadian Standards Association (CSA) to ANSI Z83.8 and CSA 2.6 for industrial/commercial installations in the United States and Canada. All heaters are available for use with either natural or propane gas. The type of gas, the firing rate, and the electrical characteristics are on the unit rating plate.

These units must be installed in accordance with local building codes. In the absence of local codes, in the United States, the unit must be installed in accordance with the National Fuel Gas Code ANSI Z223.1 (latest edition). A Canadian installation must be in accordance with the CSA B149 Installation Codes for Gas Burning Appliances and Equipment (latest edition). These codes are available from CSA Information Services, 1-800-463-6727. Local authorities having jurisdiction should be consulted before installation is made to verify local codes and installation procedure requirements.

Special Installations (Aircraft Hangars/Garages)

Installations in aircraft hangars should be in accordance with ANSI/NFPA No. 409 (latest edition), Standard for Aircraft Hangars; in public garages in accordance with ANSI/NFPA No. 88A (latest edition), Standard for Parking Structures; and for repair garages in accordance with ANSI/NFPA No. 88B (latest edition), Standard for Repair Garages.

In Canada, installations in aircraft hangars should be in accordance with the requirements of the enforcing authorities, and in public garages in accordance with CSA B149 codes.

2. Unit Heater Location

2.1 General Recommendations

WARNING: Avoid installing a unit heater in extremely drafty areas. Extreme drafts can shorten the life of the heat exchanger and/or cause safety problems.

For best results, the heater should be placed with certain rules in mind. In general, a unit should be located from 8 to 12 feet (2.4-3.7M) above the floor. Units should always be arranged to blow toward or along exposed wall surfaces, if possible. Where two or more units are installed in the same room, a general scheme of air circulation should be maintained for best results.

Suspended heaters are most effective when located as close to the working zone as possible, and this fact should be kept in mind when determining the mounting heights to be used. However, care should be exercised to avoid directing the discharged air directly on the room occupants.

Partitions, columns, counters, or other obstructions should be taken into consideration when locating the unit heater so that a minimum quantity of airflow will be deflected by such obstacles.

2. Unit Heater Location (cont'd)

2.1 General (cont'd)

When units are located in the center of the space to be heated, the air should be discharged toward the exposed walls. In large areas, units should be located to discharge air along exposed walls with extra units provided to discharge air in toward the center of the area.

At those points where infiltration of cold air is excessive, such as at entrance doors and shipping doors, it is desirable to locate the unit so that it will discharge directly toward the source of cold air from a distance of 15 to 20 feet (4.6-6.1M).

Units should not be installed closer than 18 inches (457mm) from any wall.

CAUTION: Do not locate the heater where it may be exposed to water spray, rain or dripping water.

2.2 Combustion Air Requirements for a Heater Located in a Confined Space

Do not install a unit in a confined space without providing wall openings leading to and from the space. Provide openings near the floor and ceiling for ventilation and air for combustion as shown in **FIGURE 1**, depending on the combustion air source as noted in Items 1, 2, and 3 below the illustration.

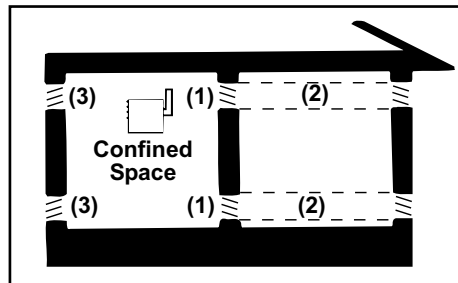
Add total BTUH of all appliances in the confined space and divide by figures below for square inch free area size of each (top and bottom) opening.

1. Air from inside the building -- openings 1 square inch free area per 1000 BTUH. Never less than 100 square inches free area for each opening. See (1) in **FIGURE 1**.

2. Air from outside through duct -- openings 1 square inch free area per 2000 BTUH. See (2) in **FIGURE 1**.

3. Air direct from outside -- openings 1 square inch free area per 4000 BTUH. See (3) in **FIGURE 1**.

FIGURE 1 - Confined Space: A space whose volume is less than 50 cubic feet per 1000 BTUH of the installed appliance input rating



NOTE: For further details on supplying combustion air to a confined space, see the National Fuel Gas Code ANSI Z223.1a (latest edition).

3. Uncrating and Preparation

3.1 Uncrating and Inspecting

This unit was test operated and inspected at the factory prior to crating and was in operating condition. If the heater has incurred any damage in shipment, document the damage with the transporting agency and immediately contact your Reznor Distributor.

Check the rating plate for the gas specifications and electrical characteristics of the heater to be sure that they are compatible with the gas and electric supplies at the installation site.

3.2 Preparing the Heater for Installation

Read this booklet and become familiar with the installation requirements of your particular heater. If you do not have knowledge of local requirements, check with the local gas company or any other local agencies who might have requirements concerning this installation. Before beginning, make preparations for necessary supplies, tools, and manpower.

Check to see if there are any field-installed options that need to be assembled to the heater prior to installation. Each of the option packages includes a list of components and step-by-step instructions. For a brief description of optional hanger kits, refer to Paragraph 5.2.1. Other option kits that should be installed prior to installation include louvers, nozzle kits, polytube adapter, duct flange, guards, vent damper, power ven-

ter, stepdown transformer, and blower/filter cabinet. After becoming familiar with the instructions, assemble and install the options that are required for your heater.

Unless the crate bottom has been removed for option installation, leave it attached until after the heater has been suspended. If the crate bottom has been removed, the bottom of the heater must be supported with plywood or appropriately placed boards. Without adequate support, the bottom access panel could be damaged.

To protect the unit during shipping, the **blower model** has special supports that must be removed before installation. Follow these instructions to remove:

□ **Blower Support Legs** -- Remove the two blower support legs and screws.

□ **Motor Shipping Block** - Remove the wooden block located under the motor bracket. Find the two rubber pads shipped in the instruction envelope. Place these pads on the ends of the motor bracket bolts.

□ **Motor Shipping Plate** -- Blower models that are equipped with motors of 3/4 HP or less have a metal shipping plate attached between the motor and the blower housing. Remove and discard the shipping plate. **Note:** On units factory equipped with an optional belt guard, the belt guard must be removed in order to reach the shipping plate.

3.2.1 Preparing for High Altitude Installation

If the heater is being installed in an altitude above 2000 ft (610M), check the rating plate to determine what must be done to prepare the heater for high altitude operation.

NOTE: A heater equipped with a two-stage valve must be factory-built for high altitude installation.

Check the rating plate, determine which circumstance below applies, and follow the instructions.

- *If the altitude range on the rating plate **agrees with the altitude at the site**, no further action is required. Proceed with the installation.*
- *If the altitude range on the rating plate **reads "Sea Level" and the altitude at the site is above 2000 ft (610M) and the heater has a single-stage gas valve**, install the heater and follow the instructions in Paragraph 6.2.1 to derate by manifold gas pressure adjustment.*

3.2.2 Assembling Vent Outlet

All heaters are designed for either a horizontal or vertical vent outlet. Sizes 25, 50, 75, 100, 165, and 200 are shipped with the vent outlet installed in the horizontal position. Sizes 125, 250, 300, and 400 require field assembly of the vent outlet. Select and follow the instructions that apply.

When the outlet is in the horizontal position, it is recommended that a 12-18" (305-457mm) piece of straight pipe be connected to the outlet before installing an elbow.

WARNING: Sizes 125, 250, 300 and 400 require field assembly of the flue outlet. Follow the instructions carefully. Failure to provide proper venting could result in death, serious injury and/or property damage.

IMPORTANT VENT OUTLET INSTALLATION NOTE -- READ BEFORE CONTINUING:

The vent outlet assembly instructions and illustrations in this section show the vent outlet being assembled in the horizontal position. To assemble the vent outlet in the vertical position, follow the instructions REVERSING the positions of the flue collar assembly and the cover.

3. Uncrating and Preparation (cont'd)

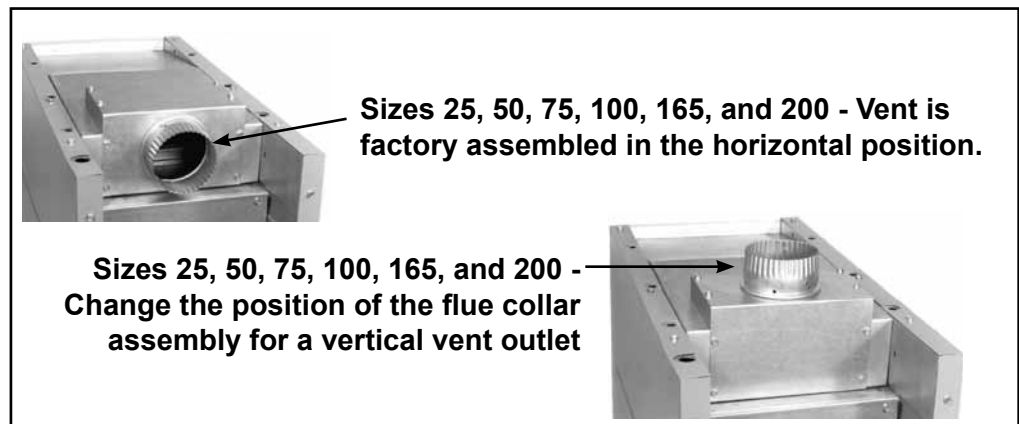
3.2 Preparing for Installation (cont'd)

FIGURE 2 - Vent Outlet Positions - Sizes 25, 50, 75, 100, 165, 200

3.2.2 Assembling Vent Outlet (cont'd)

Vent Outlet Instructions for Sizes 25, 50, 75, 100, 165 and 200

The heater in these sizes is shipped with the vent outlet in the horizontal position and requires no further field preparation. However, if a vertical vent outlet connection is needed, reverse the positions of the flat cover plate and the flue collar assembly. See **FIGURE 2**.



Vent Outlet Instructions for Size 125

A size 125 heater always requires field assembly of the vent outlet. The three sheet-metal pieces and a parts bag including the instructions and screws are shipped attached to the draft hood of the heater.

1. Remove the two center screws (one on each side) that are holding the three flue outlet pieces in place during shipping. Use these screws and the 16 screws (#10x1/2" sheetmetal screws) in the plastic bag.

2. Attach the Flue Collar Support - Size 125

- Position the support with the opening toward the back of the heater.
- Slide the flange on the front of the flue collar support **under** the draft hood (top of the heater).
- Fasten with five sheetmetal screws.

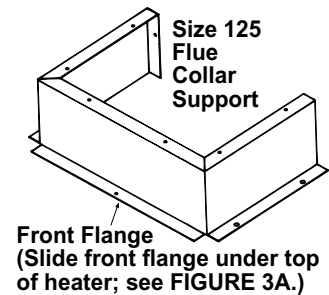
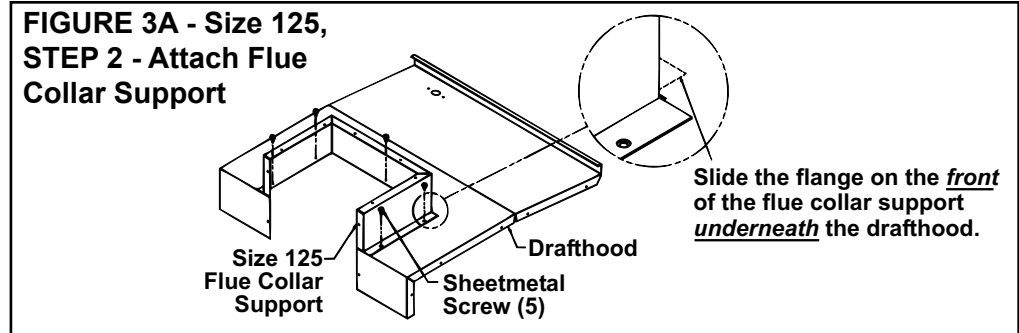


FIGURE 3A - Size 125, STEP 2 - Attach Flue Collar Support



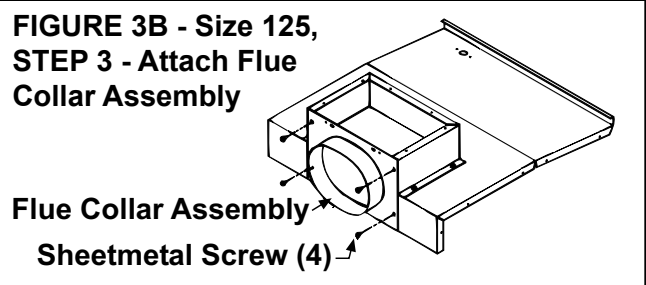
3. Attach the Flue Collar Assembly - Size 125

(If vent outlet is to be vertical; see Installation Note, page 5.)

- Position the flue collar assembly over the rear opening
- Fasten with four sheetmetal screws.

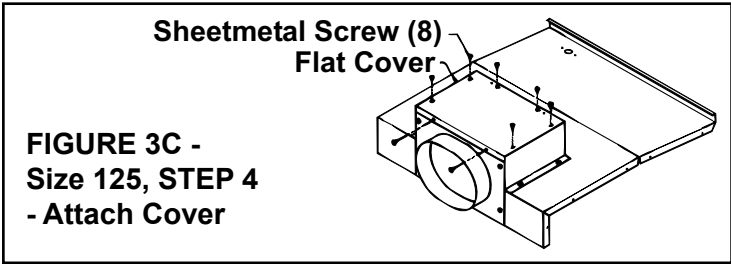
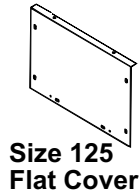


FIGURE 3B - Size 125, STEP 3 - Attach Flue Collar Assembly



4. Attach the Cover - Size 125

- Position the flat cover over the top opening
- Fasten on the top and back with eight sheetmetal screws



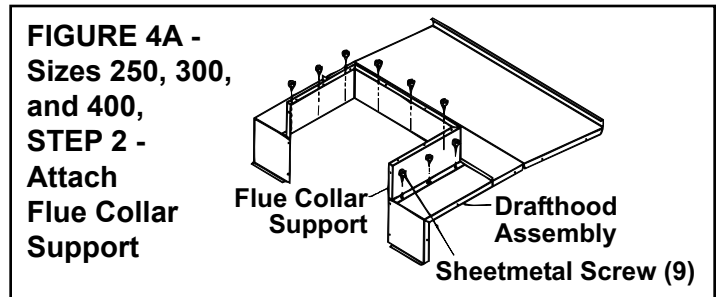
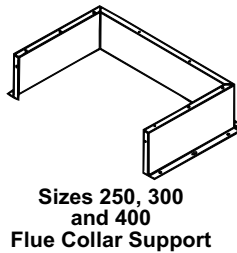
Vent Outlet Instructions for Sizes 250, 300 and 400

The vent outlet for Sizes 250, 300, and 400 always requires field assembly. The three sheetmetal pieces and a parts bag including the instructions and screws are shipped attached to the draft hood of the heater.

1. Remove the two center screws (one on each side) that are holding the three flue outlet pieces in place during shipping. Use these screws and the 24 screws (#10x1/2" sheetmetal screws) in the plastic bag.

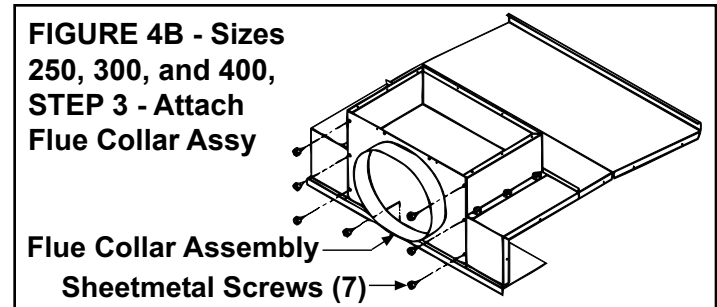
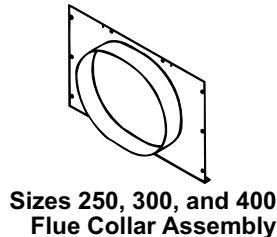
2. Attach the Flue Collar Support - Sizes 250, 300, 400

- Position the support around the hole in the draft hood with the opening toward the back of the heater
- Fasten with nine sheetmetal screws



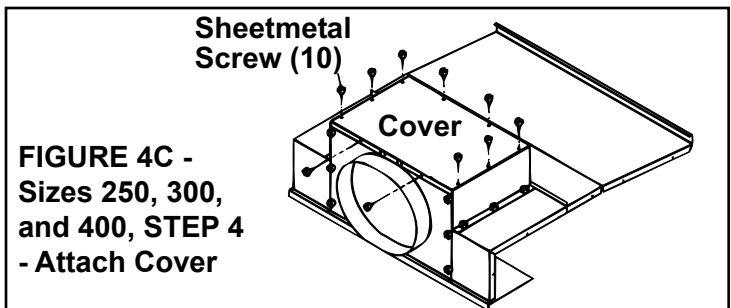
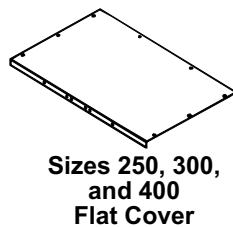
3. Attach the Flue Collar Assembly - Sizes 250, 300, 400 (If vent outlet is to be vertical; see Installation Note, page 5.)

- Position the flue collar assembly over the rear opening
- Fasten with seven sheetmetal screws



4. Attach the Cover - Sizes 250, 300, 400

- Position the flat cover over the top opening
- Fasten on the top and back with ten sheetmetal screws



3.2.3 Installing Guard Options - Model B

Guard options are designed to provide complete protection from the rotating drive and/or blower components.

Option CD12 is designed for use with Model B Sizes 25-100 with standard direct drive motor. This kit includes only the blower inlet guard.

Option CD10 is designed for use on Model B Sizes 50-400 with a belt driven motor and includes both the belt guard and the blower inlet guard.

3. Uncrating and Preparation (cont'd)

3.2 Preparing for Installation (cont'd)

3.2.3 Installing Guard Options - Model B (cont'd)



4. Clearances and Dimensions

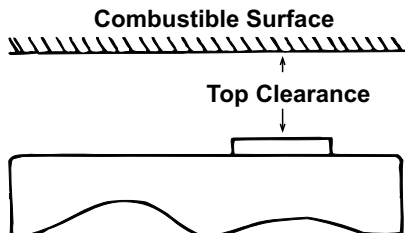
4.1 Clearances

Units must be installed so that the following clearances are provided for combustion air space, service and inspection, and for proper spacing from combustible construction. Clearance to combustibles is defined as the minimum distance from the heater to a surface or object that is necessary to ensure that a surface temperature of 90°F above the surrounding ambient temperature is not exceeded.

| Model | | Required Clearances | | | | |
|---------------------|-----------|---------------------|----------------|--------------|--------------|--------------|
| Type | Size | Top * | Flue Connector | Sides | Bottom** | Rear*** |
| Fan (Model F) | 25 - 125 | 2" 51mm | 6" 152mm | 18" 457mm | 12" 305mm | 24" 610mm |
| | 165 - 400 | 6" 152mm | 6" 152mm | 18" 457mm | 12" 305mm | 24" 610mm |
| Blower (Model B) | 25 - 400 | 6" 152mm | 6" 152mm | 18" 457mm | 12" 305mm | 24" 610mm |

Notes:

- * Measure Top Clearance as illustrated.
- ** When supplied with optional downturn nozzle, bottom clearance is 42" (1067mm). For service purposes, on standard units, bottom clearance exceeding minimum (12" or 305mm) is not required but may be desirable.
- *** For service purposes only, rear **must** have 24" (610mm) clearance.

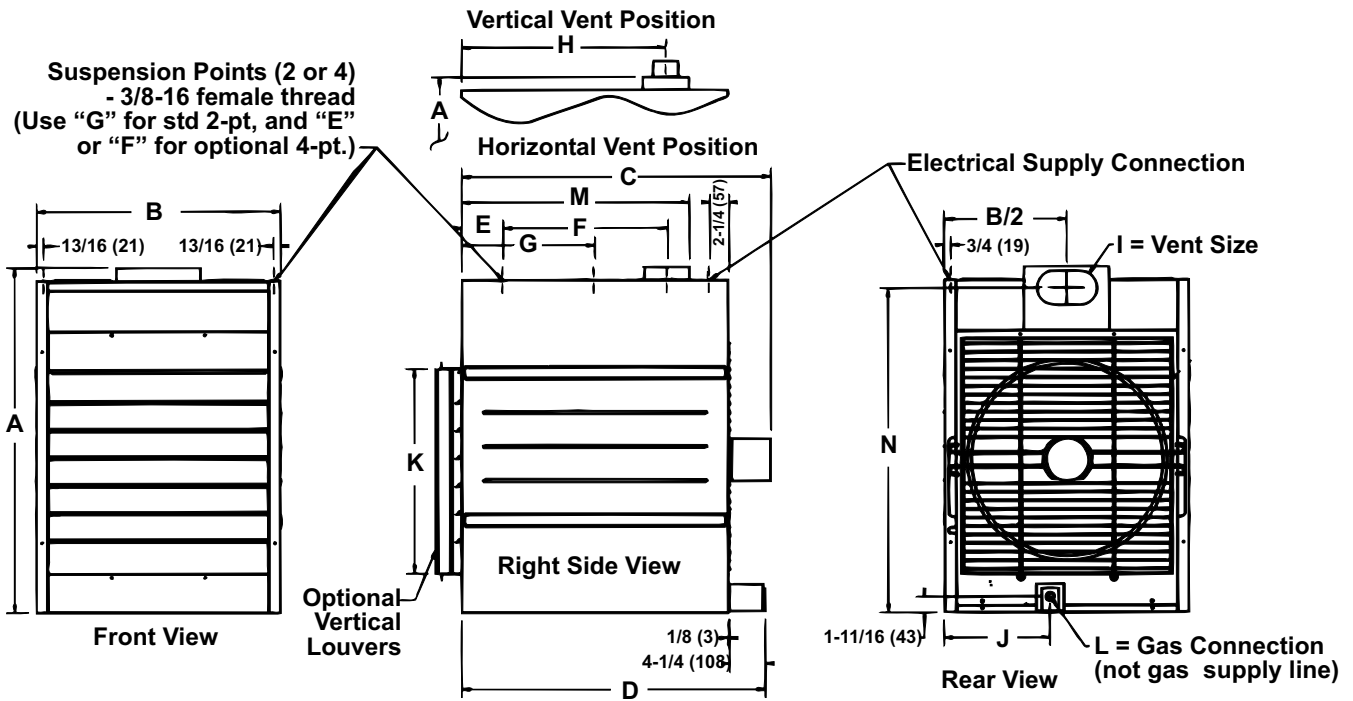


All fuel-burning equipment must be supplied with the air that enters into the combustion process and is then vented to the outdoors. Sufficient air must enter the equipment location to replace that exhausted through the heater vent system. In the past, the infiltration of outside air assumed in heat loss calculations (one air change per hour) was assumed to be sufficient. However, current construction methods using more insulation, vapor barriers, tighter fitting and gasketed doors and windows or weather-stripping, and mechanical exhaust fans may now require the introduction of outside air through wall openings or ducts.

The requirements for combustion and ventilation air depend upon whether the unit is located in a confined or unconfined space. An "unconfined space" is defined as a space whose volume is not less than 50 cubic feet per 1000 BTUH of the installed appliance. **Under all conditions**, enough air must be provided to ensure there will not be a negative pressure condition within the equipment room or space. For specific requirements for confined space installation, see Paragraph 2.2.

4.2 Dimensions

FIGURE 6 - Model F Dimensions - inches (mm)

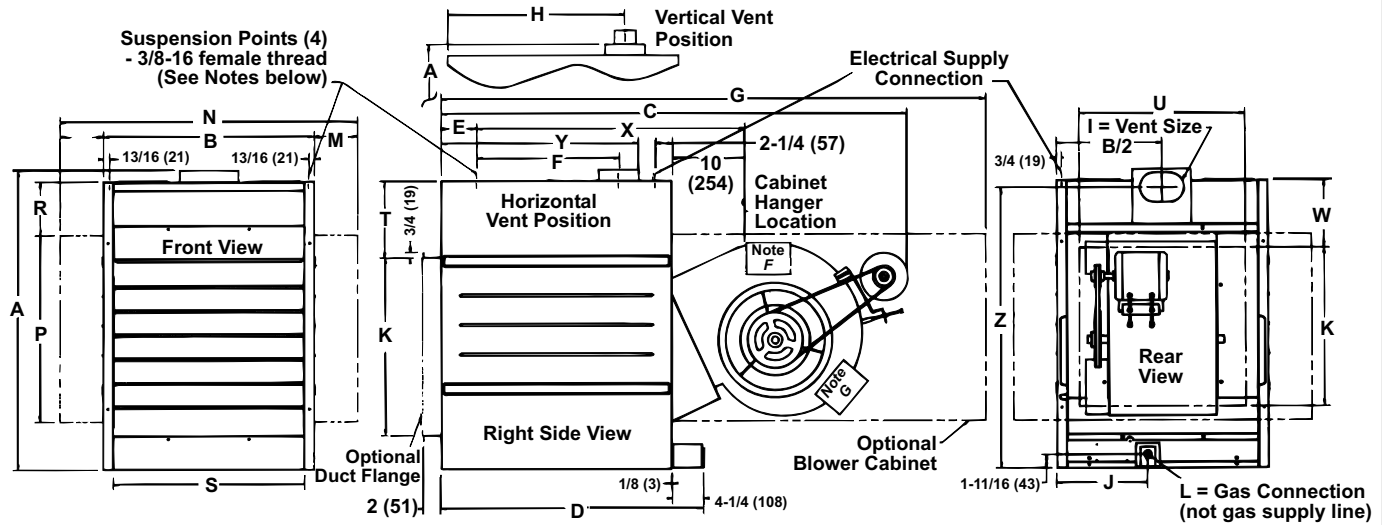


| Size | A | B | C | D | E | F | G | H | I | J | K | L | | M | N |
|----------------------------|---------|----------|----------|----------|---------|----------|----------|----------|----------|----------|-----|-----|-----|--------|----------|
| | | | | | | | | | | | | Nat | Pro | | |
| Dimensions (inches) | | | | | | | | | | | | | | | |
| 25 | 30-5/32 | 13-9/16 | 27-1/16 | 31-7/16 | 5-27/32 | 14-7/16 | 14-1/32 | 19 | 4 Rnd | 10-9/32 | 16 | 1/2 | 1/2 | 21-1/2 | 27-21/32 |
| 50 | 30-5/32 | 13-9/16 | 27-1/16 | 31-7/16 | 5-27/32 | 14-7/16 | 14-1/32 | 19 | 4 Rnd | 10-9/32 | 16 | 1/2 | 1/2 | 21-1/2 | 27-21/32 |
| 75 | 30-5/32 | 15-9/16 | 27-1/16 | 31-7/16 | 5-27/32 | 14-7/16 | 14-1/32 | 19 | 5 Oval | 10-17/32 | 16 | 1/2 | 1/2 | 21-1/2 | 27-21/32 |
| 100 | 30-5/32 | 17-9/16 | 30-7/16 | 31-7/16 | 5-27/32 | 14-7/16 | 14-1/32 | 19 | 6 Oval | 12-29/32 | 16 | 1/2 | 1/2 | 21-1/2 | 27-21/32 |
| 125 | 32 | 23-5/16 | 30-7/16 | 31-7/16 | 5-27/32 | 14-7/16 | 14-1/32 | 17-15/16 | 7 Oval | 14-7/16 | 16 | 1/2 | 1/2 | 21-1/2 | 28-1/2 |
| 165 | 40-5/32 | 20-5/16 | 35-7/16 | 35-15/16 | 4-7/8 | 19-15/32 | 15-23/32 | 23-13/32 | 8 Oval | 14-9/32 | 24 | 1/2 | 1/2 | 27 | 36-25/32 |
| 200 | 40-5/32 | 23-5/16 | 36-3/16 | 35-15/16 | 4-7/8 | 19-15/32 | 15-23/32 | 23-13/32 | 8 Oval | 14-13/32 | 24 | 1/2 | 1/2 | 27 | 36-25/32 |
| 250 | 40-5/32 | 28-13/16 | 36-3/16 | 35-15/16 | 4-7/8 | 19-15/32 | 15-23/32 | 21-13/16 | 10 Oval | 12-11/32 | 24 | 1/2 | 1/2 | 27 | 38-3/8 |
| 300 | 40-5/32 | 28-13/16 | 36-11/16 | 35-15/16 | 4-7/8 | 19-15/32 | 15-23/32 | 21-13/16 | 10 Oval | 12-11/32 | 24 | 3/4 | 1/2 | 27 | 38-3/8 |
| 400 | 40-5/32 | 37-1/16 | 37-5/16 | 35-15/16 | 4-7/8 | 19-15/32 | 15-23/32 | 21-13/16 | 12 Oval | 13 | 24 | 3/4 | 1/2 | 27 | 38-3/8 |
| Dimensions (mm) | | | | | | | | | | | | | | | |
| 25 | 766 | 344 | 687 | 799 | 148 | 367 | 356 | 19 | 102 Rnd | 261 | 406 | 13 | 13 | 546 | 702 |
| 50 | 766 | 344 | 687 | 799 | 148 | 367 | 356 | 19 | 102 Rnd | 261 | 406 | 13 | 13 | 546 | 702 |
| 75 | 766 | 395 | 687 | 799 | 148 | 367 | 356 | 19 | 127 Oval | 267 | 406 | 13 | 13 | 546 | 702 |
| 100 | 766 | 446 | 773 | 799 | 148 | 367 | 356 | 19 | 152 Oval | 328 | 406 | 13 | 13 | 546 | 702 |
| 125 | 813 | 592 | 773 | 799 | 148 | 367 | 356 | 17-15/16 | 178 Oval | 367 | 406 | 13 | 13 | 546 | 724 |
| 165 | 1020 | 516 | 900 | 913 | 124 | 498 | 399 | 23-13/32 | 203 Oval | 363 | 610 | 13 | 13 | 686 | 934 |
| 200 | 1020 | 592 | 919 | 913 | 124 | 498 | 399 | 23-13/32 | 203 Oval | 366 | 610 | 13 | 13 | 686 | 934 |
| 250 | 1020 | 732 | 919 | 913 | 124 | 498 | 399 | 21-13/16 | 254 Oval | 314 | 610 | 13 | 13 | 686 | 975 |
| 300 | 1020 | 732 | 932 | 913 | 124 | 498 | 399 | 21-13/16 | 254 Oval | 314 | 610 | 19 | 13 | 686 | 975 |
| 400 | 1020 | 941 | 948 | 913 | 124 | 498 | 399 | 21-13/16 | 305 Oval | 330 | 610 | 19 | 13 | 686 | 975 |

4. Clearances and Dimensions (cont'd)

4.2 Dimensions (cont'd)

FIGURE 7 - Model B Dimensions - inches (mm)



Dimensions - inches

| Size | A | B | C ^H | D | E | F ^D Hanger | G ^{AC} | H | I | J | K ^{AB} | L | |
|------|---------|----------|----------------|----------|---------|--------------------------|-----------------|----------|---------|----------|-----------------|-----|---------|
| | | | | | | | | | | | | Nat | Propane |
| 25 | 30-5/32 | 13-9/16 | 43-3/8 | 31-7/16 | 5-27/32 | 14-7/16 | 61-3/8 | 19 | 4 Rnd | 10-9/32 | 16 | 1/2 | 1/2 |
| 50 | 30-5/32 | 13-9/16 | 50 | 31-7/16 | 5-27/32 | 14-7/16 | 61-3/8 | 19 | 4 Rnd | 10-9/32 | 16 | 1/2 | 1/2 |
| 75 | 30-5/32 | 15-9/16 | 50 | 31-7/16 | 5-27/32 | 14-7/16 | 61-3/8 | 19 | 5 Oval | 10-17/32 | 16 | 1/2 | 1/2 |
| 100 | 30-5/32 | 17-9/16 | 50 | 31-7/16 | 5-27/32 | 14-7/16 | 61-3/8 | 19 | 6 Oval | 12-29/32 | 16 | 1/2 | 1/2 |
| 125 | 32 | 23-5/16 | 47-1/2 | 31-7/16 | 5-27/32 | 14-7/16 | 65-29/32 | 17-15/16 | 7 Oval | 14-7/16 | 16 | 1/2 | 1/2 |
| 165 | 40-5/32 | 20-5/16 | 61 | 35-15/16 | 4-7/8 | 19-15/32 | 76-1/8 | 23-13/32 | 8 Oval | 14-9/32 | 24 | 1/2 | 1/2 |
| 200 | 40-5/32 | 23-5/16 | 66-1/2 | 35-15/16 | 4-7/8 | 19-15/32 | 76-1/8 | 23-13/32 | 8 Oval | 14-13/32 | 24 | 1/2 | 1/2 |
| 250 | 43-9/16 | 28-13/16 | 66-1/2 | 35-15/16 | 4-7/8 | 19-15/32 | 76-1/8 | 21-13/16 | 10 Oval | 12-11/32 | 24 | 1/2 | 1/2 |
| 300 | 43-9/16 | 28-13/16 | 66-1/2 | 35-15/16 | 4-7/8 | 19-15/32 | 76-1/8 | 21-13/16 | 10 Oval | 12-11/32 | 24 | 3/4 | 1/2 |
| 400 | 43-9/16 | 37-1/16 | 66-1/2 | 35-15/16 | 4-7/8 | 19-15/32 | 76-1/8 | 21-13/16 | 12 Oval | 13 | 24 | 3/4 | 1/2 |

| Size | M ^A | N ^A | P ^A | R ^A | S ^B | T ^B | U ^A | W ^A | X ^E Hanger | Y | Z |
|------|----------------|----------------|----------------|----------------|----------------|----------------|----------------|----------------|-----------------------|--------|----------|
| 25 | 3-23/32 | 20-15/16 | 17-3/4 | 5-1/4 | 10-3/4 | 8-7/16 | 14-3/4 | 6-3/16 | 31-7/32 | 21-1/2 | 27-21/32 |
| 50 | 3-23/32 | 20-15/16 | 17-3/4 | 5-1/4 | 10-3/4 | 8-7/16 | 14-3/4 | 6-3/16 | 31-7/32 | 21-1/2 | 27-21/32 |
| 75 | 2-23/32 | 20-15/16 | 17-3/4 | 5-1/4 | 12-3/4 | 8-7/16 | 14-3/4 | 6-3/16 | 31-7/32 | 21-1/2 | 27-21/32 |
| 100 | 1-23/32 | 20-15/16 | 17-3/4 | 5-1/4 | 14-3/4 | 8-7/16 | 14-3/4 | 6-3/16 | 31-7/32 | 21-1/2 | 27-21/32 |
| 125 | 1-11/32 | 25-15/16 | 17-3/4 | 5-1/4 | 20-1/2 | 8-7/16 | 20-1/2 | 6-3/16 | 35-3/4 | 21-1/2 | 28-1/2 |
| 165 | 2-27/32 | 25-15/16 | 25-1/4 | 7-1/4 | 17-1/2 | 11-7/16 | 20-1/2 | 7-15/16 | 36-11/16 | 27 | 36-25/32 |
| 200 | 1-11/32 | 25-15/16 | 25-1/4 | 7-1/4 | 20-1/2 | 11-7/16 | 20-1/2 | 7-15/16 | 36-11/16 | 27 | 36-25/32 |
| 250 | 5-29/32 | 40-9/16 | 25-1/4 | 7-1/4 | 26 | 11-7/16 | 26 | 7-15/16 | 36-11/16 | 27 | 38-3/8 |
| 300 | 5-29/32 | 40-9/16 | 25-1/4 | 7-1/4 | 26 | 11-7/16 | 26 | 7-15/16 | 36-11/16 | 27 | 38-3/8 |
| 400 | 6-25/32 | 50-9/16 | 25-1/4 | 7-1/4 | 34-1/4 | 11-7/16 | 34-1/4 | 7-15/16 | 36-11/16 | 27 | 38-3/8 |

NOTES:

^A When equipped with optional blower cabinet.

^B When equipped with optional duct flange.

^C Dimension includes a 3/4" flange on the rear of the blower cabinet.

^D Use with 4-point suspension without blower cabinet. If installing hanger kit Option CK19, suspension points change; see Paragraph 5.2.1.

^E Use with 4-point suspension with blower cabinet.

^F Contactor is standard on Models 300 and 400; optional on other sizes.

^G Contactor location with optional three phase motors on Sizes 50, 75, 100 and 125.

^H Deduct 6-5/8" (168mm) on Sizes 50, 75, and 100 when equipped with direct drive motor.

Dimensions - mm

| Size | A | B | C ^H | D | E | F ^D Hanger | G ^{AC} | H | I | J | K ^{AB} | L | |
|------|------|-----|----------------|-----|-----|--------------------------|-----------------|-----|----------|-----|-----------------|---------|---------|
| | | | | | | | | | | | | Natural | Propane |
| 25 | 766 | 344 | 1102 | 799 | 148 | 367 | 1559 | 483 | 102 Rnd | 261 | 406 | 13 | 13 |
| 50 | 766 | 344 | 1270 | 799 | 148 | 367 | 1559 | 483 | 102 Rnd | 261 | 406 | 13 | 13 |
| 75 | 766 | 395 | 1270 | 799 | 148 | 367 | 1559 | 483 | 127 Oval | 267 | 406 | 13 | 13 |
| 100 | 766 | 446 | 1270 | 799 | 148 | 367 | 1559 | 483 | 152 Oval | 328 | 406 | 13 | 13 |
| 125 | 813 | 592 | 1207 | 799 | 148 | 367 | 1674 | 456 | 178 Oval | 367 | 406 | 13 | 13 |
| 165 | 1020 | 516 | 1549 | 913 | 124 | 495 | 1934 | 595 | 203 Oval | 363 | 610 | 13 | 13 |
| 200 | 1020 | 592 | 1689 | 913 | 124 | 495 | 1934 | 595 | 203 Oval | 366 | 610 | 13 | 13 |
| 250 | 1020 | 732 | 1689 | 913 | 124 | 495 | 1934 | 544 | 254 Oval | 314 | 610 | 13 | 13 |
| 300 | 1020 | 732 | 1689 | 913 | 124 | 495 | 1934 | 544 | 254 Oval | 314 | 610 | 19 | 13 |
| 400 | 1020 | 941 | 1689 | 913 | 124 | 495 | 1934 | 544 | 305 Oval | 330 | 610 | 19 | 13 |

| Size | M ^A | N ^A | P ^A | R ^A | S ^B | T ^B | U ^A | W ^A | X ^E Hanger | Y | Z |
|------|----------------|----------------|----------------|----------------|----------------|----------------|----------------|----------------|-----------------------|-----|-----|
| 25 | 94 | 532 | 481 | 133 | 273 | 214 | 375 | 157 | 793 | 546 | 702 |
| 50 | 94 | 532 | 481 | 133 | 273 | 214 | 375 | 157 | 793 | 546 | 702 |
| 75 | 69 | 532 | 481 | 133 | 324 | 214 | 375 | 157 | 793 | 546 | 702 |
| 100 | 44 | 532 | 481 | 133 | 375 | 214 | 375 | 157 | 793 | 546 | 702 |
| 125 | 34 | 532 | 481 | 133 | 521 | 214 | 521 | 157 | 908 | 546 | 724 |
| 165 | 72 | 659 | 641 | 184 | 445 | 291 | 521 | 202 | 932 | 686 | 934 |
| 200 | 34 | 659 | 641 | 184 | 521 | 291 | 521 | 202 | 932 | 686 | 934 |
| 250 | 150 | 1030 | 641 | 184 | 660 | 291 | 660 | 202 | 932 | 686 | 975 |
| 300 | 150 | 1030 | 641 | 184 | 660 | 291 | 660 | 202 | 932 | 686 | 975 |
| 400 | 172 | 1284 | 641 | 184 | 870 | 291 | 870 | 202 | 932 | 686 | 975 |

NOTES:

^A When equipped with optional blower cabinet.

^B When equipped with optional duct flange.

^C Dimension includes a 3/4" flange on the rear of the blower cabinet.

^D Use with 4-point suspension without blower cabinet. If installing hanger kit Option CK19, suspension points change; see Paragraph 5.2.1.

^E Use with 4-point suspension with blower cabinet.

^F Contactor is standard on Models 300 and 400; optional on other sizes.

^G Contactor location with optional three phase motors on Sizes 50, 75, 100 and 125.

^H Deduct 6-5/8" (168mm) on Sizes 50, 75, and 100 when equipped with direct drive motor.

5. Hanging the Heater

NOTE: If the installation includes an optional stepdown transformer kit (Option CF or CG), the stepdown transformer bracket is part of the heater suspension and must be installed prior to hanging the heater. Follow the instructions on the installation sheet included with the option kit.

5.1 Weights

Before suspending the unit, check the supporting structure to be used to verify that it has sufficient load-carrying capacity to support the weight of the heater.

| Model Type | | Net Weight - lbs and kg | | | | | | | | | |
|------------|-----|-------------------------|-----|-----|-----|-----|-----|-----|-----|-----|-----|
| | | Size | | | | | | | | | |
| | | 25 | 50 | 75 | 100 | 125 | 165 | 200 | 250 | 300 | 400 |
| Fan | lbs | 72 | 79 | 88 | 97 | 127 | 149 | 170 | 204 | 221 | 276 |
| | kg | 33 | 36 | 40 | 44 | 58 | 68 | 77 | 93 | 100 | 125 |
| Blower | lbs | 93 | 100 | 114 | 126 | 150 | 201 | 235 | 273 | 296 | 390 |
| | kg | 42 | 45 | 52 | 57 | 68 | 91 | 107 | 124 | 134 | 177 |

5.2 Lifting and Suspending

A **fan-type unit heater** is equipped with standard two-point suspension. A 3/8-16 threaded hanger bracket assembly is located on each side of the heater. If a fan-type unit has been ordered with optional, factory-installed, four-point suspension (Option BJ6), it will have two threaded hanger brackets on each side.

A **blower-type heater** is equipped with standard four-point suspension. Two 3/8-16 threaded hanger bracket assemblies are located on each side of the unit. Each hanger bracket assembly is designed for threaded rod attachment.

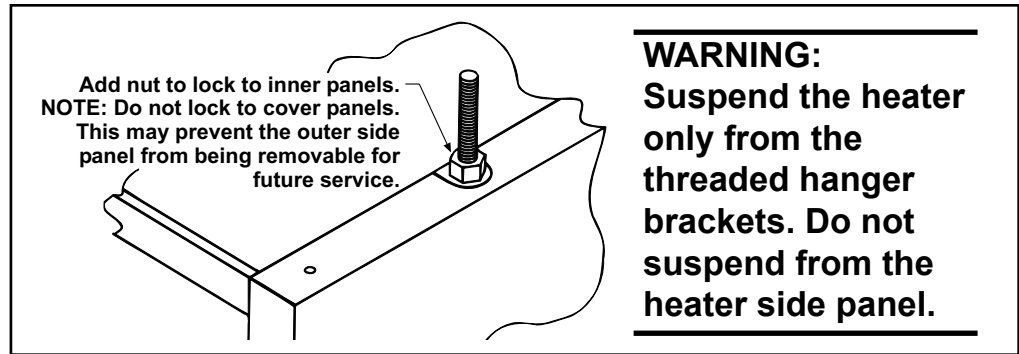
For both "standard" and "optional" suspension point dimensions, see Dimension Tables in Paragraph 4.2. (Note: If installing Option CK19 hanger kit, suspension points change; see **FIGURE 11, page 13.**)

5. Hanging the Heater (cont'd)

5.2 Lifting and Suspending (cont'd)

FIGURE 8 - Suspension Point

WARNING: Unit must be level for proper operation. Do not place or add additional weight to the suspended heater. See Hazard Levels, page 2.



When the heater is lifted for suspension, the bottom must be protected. If the wooden crate bottom has been removed, the bottom of the heater will have to be supported with plywood or other appropriately placed material. If the bottom is not supported, the bottom access panel could be damaged. Also, when lifting a blower unit, support the blower and motor to prevent the unit from tipping.

All blower models have legs that support the blower assembly during shipping. After the unit is suspended, these legs should be removed.

Be sure that the threaded hanger rods are locked to the heater as shown in **FIGURE 8**.

If an **optional downturn air nozzle** is used, the unit must be suspended from four points to ensure level suspension. Two hanger brackets are included in the downturn option package and must be field-installed on fan-type units with standard two-point suspension. For additional information, refer to Paragraph 28 and the instructions that are furnished with the option package.

When **blower-type** units are equipped with an **optional blower/filter cabinet**, there are two suspension points on the blower cabinet hanger bar. Suspend a unit equipped with a blower/filter cabinet from four points, using the two heater hanger bracket assemblies closest to the front of the heater and the two suspension points on the blower/filter cabinet.

If one of the four optional, field-installed hanger kits has been ordered for your heater, it will have been shipped separately. Each option package includes a list of components and complete, step-by-step assembly instructions.

5.2.1 Optional, Field-Installed Hanger Kits

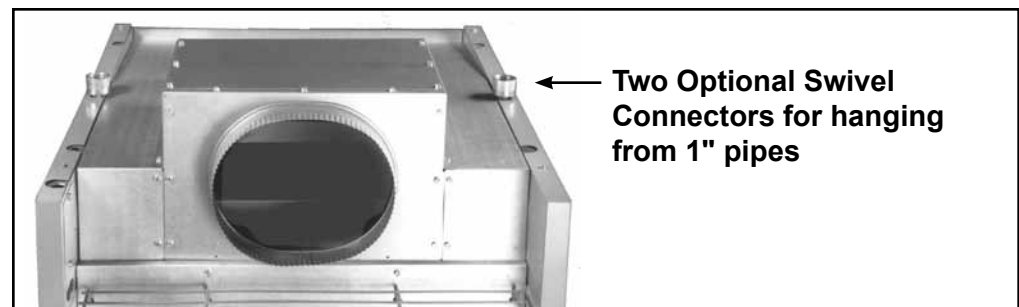
1) Four-Point Suspension (fan models only) - Option CK7

This option kit is designed to convert a fan-type heater from standard two-point suspension to four-point suspension. The kit contains two additional hanger brackets.

2) Two-Point Swivel Connectors (fan models only) - Option CK8 (See FIGURE 9)

The purpose of this option kit is to adapt the standard hanger bracket so that the heater can be suspended from 1", threaded, stationary pipe. The swivel connector screws "into" the threaded hanger bracket on the heater and "onto" the 1" threaded pipe used for hanging the heater. The kit includes two swivel hanger connector assemblies and two lock washers.

FIGURE 9 - Two-Point Suspension with Swivel Connections (fan models only)



3) Four-Point with Swivel Connectors (fan-models only) - Option CK9 (See FIGURE 10)

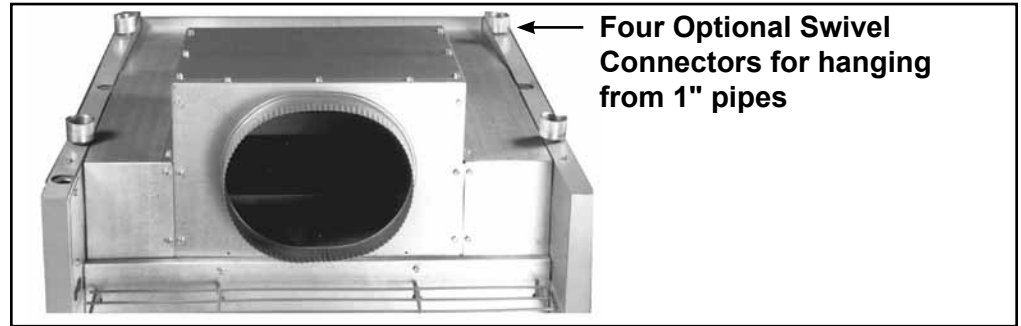
This option package is designed to convert a fan-type heater from standard two-point suspension to four-point suspension with swivel connectors. By installing this kit the standard fan-type heater can be hung from four 1", threaded, stationary pipes. The kit

includes two hanger bracket assemblies, four swivel hanger connector assemblies and four lock washers.

4) Four-Point Swivel Connectors - Option CK10 (See FIGURE 10)

This option package is used on a heater that is already equipped with four-point suspension to adapt it for suspension from four 1", threaded, stationary pipes. The kit includes four swivel hanger connector assemblies and four lock washers.

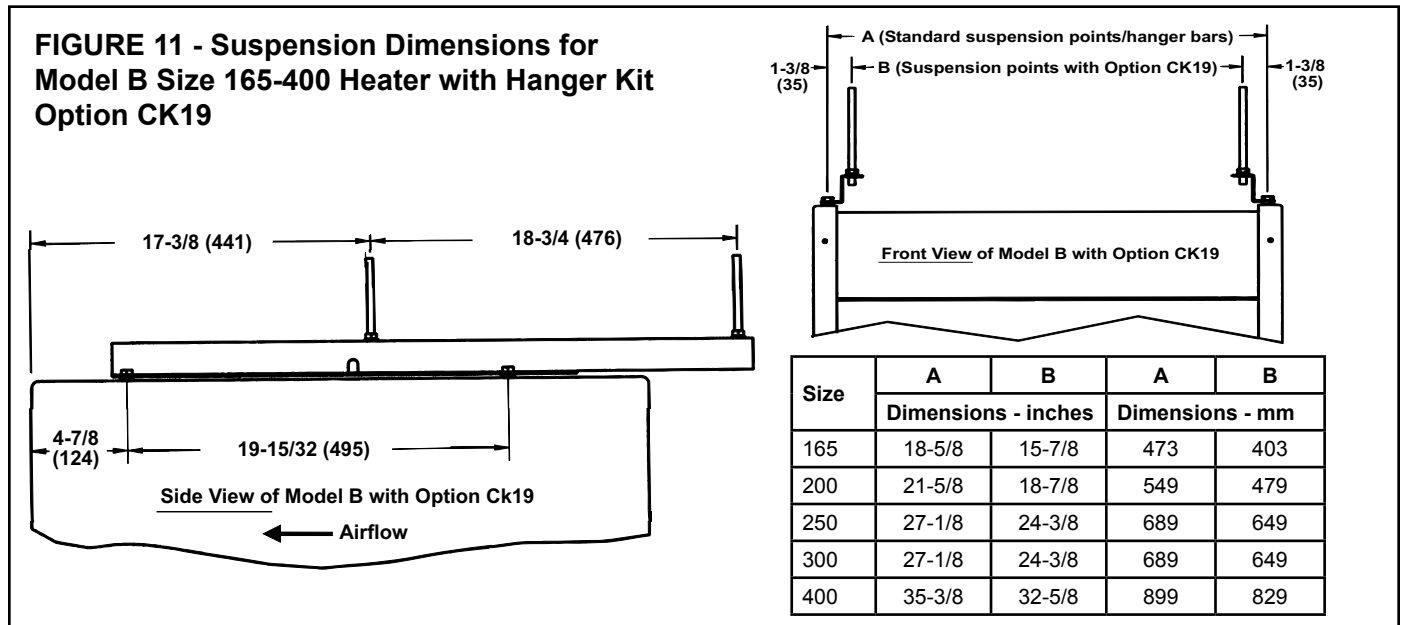
FIGURE 10 - Four-Point Suspension with Swivel Connections (Applies to both fan and blower models)



5) Special Four-Point Suspension with Nearly Equal Loading (applies to Model B 165-400 only) - Option CK19 (See FIGURE 11)

This suspension option is designed for special applications when a suspension system is needed that has nearly equal loading at all four suspension points. Use this option in installations with spring isolation designed for seismic protection or when threaded rod hangers are longer than twelve inches.

Suspension points change with the addition of the hanger bars in kit Option CK19; see FIGURE 11.



6. Mechanical

6.1 Gas Piping and Pressures

6.1.1 Gas Supply and Connections

WARNING: This appliance is equipped for a maximum gas supply pressure of 1/2 psi, 3.5 kPa, or 14 inches water column. Supply pressure higher than 1/2 psi requires installation of an additional service regulator external to the unit.

PRESSURE TESTING SUPPLY PIPING

Test Pressures Above 1/2 PSI: Disconnect the heater and manual valve from the gas supply line which is to be tested. Cap or plug the supply line.

Test Pressures Below 1/2 PSI: Before testing, close the manual valve on the heater.

6. Mechanical (cont'd)

6.1 Gas Piping and Pressures (cont'd)

All piping must be in accordance with requirements outlined in the National Fuel Gas Code ANSI/Z223.1a (latest edition), published by the American Gas Association or CAN/CSA-B149.1 and B149.2, published by the Canadian Gas Association (See Paragraph 1.4). Gas supply piping installation should conform with good practice and with local codes.

Unit heaters for natural gas are orificed for operation with gas having a heating value of 1000 (± 50) BTU per cubic ft. If the gas at the installation does not meet this specification, consult the factory for proper orificing.

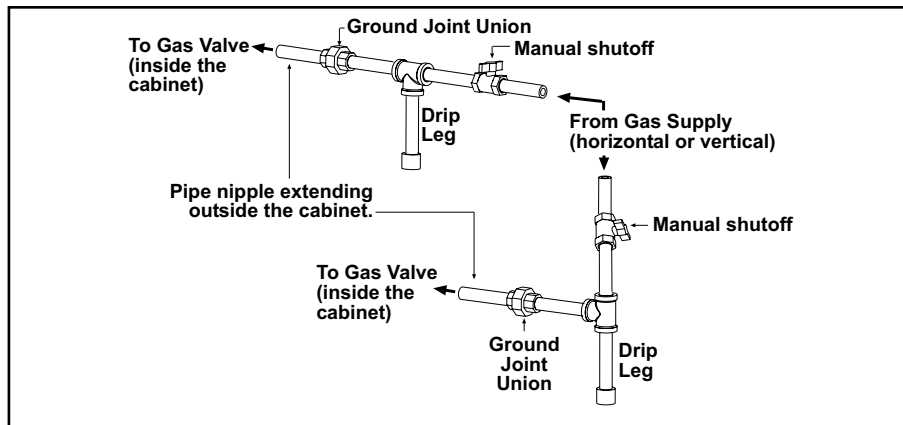
Pipe joint compounds (pipe dope) shall be resistant to the action of liquefied petroleum gas or any other chemical constituents of the gas being supplied.

Install a ground joint union and manual shut-off valve upstream of the unit control system, as shown in **FIGURE 12**. The 1/8" plugged tapping in the shut-off valve provides connection for supply line pressure test gauge. The National Fuel Gas Code requires the installation of a trap with a minimum 3" drip leg. Local codes may require a minimum drip leg longer than 3" (typically 6").

Gas connection sizes are included in the Dimension Tables in Paragraph 4.2. After all connections are made, disconnect the pilot supply at the control valve and bleed the system of air. Reconnect the pilot line and leak-test all connections by brushing on a soap solution.

WARNING: All components of a gas supply system must be leak tested prior to placing equipment in service. NEVER TEST FOR LEAKS WITH AN OPEN FLAME. Failure to comply could result in personal injury, property damage or death.

FIGURE 12 - Supply Piping Connection



Sizing a Gas Supply Line

| Capacity of Piping | | | | | | | | | | | | |
|--|------------------|---------|---------|---------|---------|---------|---------|---------|---------|---------|---------|---------|
| Cubic Feet per Hour based on 0.3" w.c. Pressure Drop | | | | | | | | | | | | |
| Specific Gravity for Natural Gas -- 0.6 (Natural Gas -- 1000 BTU/Cubic Ft) | | | | | | | | | | | | |
| Specific Gravity for Propane Gas -- 1.6 (Propane Gas -- 2550 BTU/Cubic Ft) | | | | | | | | | | | | |
| Length of Pipe | Diameter of Pipe | | | | | | | | | | | |
| | 1/2" | | 3/4" | | 1" | | 1-1/4" | | 1-1/2" | | 2" | |
| | Natural | Propane | Natural | Propane | Natural | Propane | Natural | Propane | Natural | Propane | Natural | Propane |
| 20' | 92 | 56 | 190 | 116 | 350 | 214 | 730 | 445 | 1100 | 671 | 2100 | 1281 |
| 30' | 73 | 45 | 152 | 93 | 285 | 174 | 590 | 360 | 890 | 543 | 1650 | 1007 |
| 40' | 63 | 38 | 130 | 79 | 245 | 149 | 500 | 305 | 760 | 464 | 1450 | 885 |
| 50' | 56 | 34 | 115 | 70 | 215 | 131 | 440 | 268 | 670 | 409 | 1270 | 775 |
| 60' | 50 | 31 | 105 | 64 | 195 | 119 | 400 | 244 | 610 | 372 | 1105 | 674 |
| 70' | 46 | 28 | 96 | 59 | 180 | 110 | 370 | 226 | 560 | 342 | 1050 | 641 |
| 80' | 43 | 26 | 90 | 55 | 170 | 104 | 350 | 214 | 530 | 323 | 990 | 604 |
| 90' | 40 | 24 | 84 | 51 | 160 | 98 | 320 | 195 | 490 | 299 | 930 | 567 |
| 100' | 38 | 23 | 79 | 48 | 150 | 92 | 305 | 186 | 460 | 281 | 870 | 531 |
| 125' | 34 | 21 | 72 | 44 | 130 | 79 | 275 | 168 | 410 | 250 | 780 | 476 |
| 150' | 31 | 19 | 64 | 39 | 120 | 73 | 250 | 153 | 380 | 232 | 710 | 433 |
| 175' | 28 | 17 | 59 | 36 | 110 | 67 | 225 | 137 | 350 | 214 | 650 | 397 |
| 200' | 26 | 16 | 55 | 34 | 100 | 61 | 210 | 128 | 320 | 195 | 610 | 372 |

Note: When sizing supply lines, consider possibilities of future expansion and increased requirements.

Refer to National Fuel Gas Code for additional information on line sizing.

6.1.2 Manifold or Orifice Pressure Settings

WARNING:
Manifold gas pressure must never exceed 3.5" w.c. for natural gas and 10" w.c. for propane.

Instructions on How to Check Valve Outlet (Manifold) Pressure (can only be done after heater is installed):

CAUTION: DO NOT bottom out the gas valve regulator adjusting screw. This can result in unregulated manifold pressure causing excess overfire and heat exchanger failure.

Measuring manifold gas pressure cannot be done until the heater is in operation. It is included in the steps of the "Check-Test-Start" procedure in Paragraph 9. The following warnings and instructions apply.

For Natural Gas: When the heater leaves the factory, the combination gas valve is set so that the outlet gas pressure of a single-stage valve or high fire of a two-stage valve is regulated to 3.5" w.c. Low fire on a two-stage valve is set to 0.9" w.c. Inlet supply pressure to the valve for natural gas must be a minimum of 5" w.c. or as noted on the rating plate and a maximum of 14" w.c.

For Propane: When the heater leaves the factory, the combination gas valve is set so that the outlet gas pressure of a single-stage valve or high fire of a two-stage valve is regulated to 10" w.c. Low fire on a two-stage valve is set to 3.8" w.c. Inlet supply pressure to the valve for propane gas must be a minimum of 11" w.c. and a maximum of 14" w.c.

Before attempting to measure or adjust valve outlet (manifold) gas pressure, the inlet supply pressure **must** be within the specified range both when the heater is in operation and on standby. Incorrect inlet pressure could cause excessive manifold gas pressure immediately or at some future time. If natural gas supply pressure is too high, install a regulator in the supply line before it reaches the heater. If natural gas supply pressure is too low, contact your gas supplier.

1) With the manual valve positioned to prevent flow to the main burners, connect a manometer to the 1/8" pipe outlet pressure tap in the valve. **NOTE:** A manometer (fluid-filled gauge) is recommended rather than a spring type gauge due to the difficulty of maintaining calibration of a spring type gauge.

2) Open the valve and operate the heater. Measure the outlet pressure of the gas valve. To measure low stage pressure on units equipped with a two-stage valve, disconnect the wire from the "HI" terminal on the valve. (Be sure to reconnect the wire.)

Normally adjustments should not be necessary to the factory preset regulator. (For high altitude settings, see below.) If adjustment is necessary, remove the cap from the adjustment screw(s). Set pressure to correct settings by turning the regulator screw IN (clockwise) to increase pressure. Turn regulator screw OUT (counterclockwise) to decrease pressure.

Derating by Valve Outlet (Manifold) Pressure Adjustment for High Altitude Operation

If the heater is being installed above 2000 ft (610M) and it was determined in Paragraph 3.2.1 that derating by valve outlet pressure adjustment is permissible, follow the instructions that follow.

Instructions for Derating a Heater by Adjusting Valve Outlet Pressure (The heater **MUST** have a single-stage gas valve and **MUST** be factory-equipped for sea level operation.)

1. Check the rating plate to be certain that the heater is equipped for sea level operation. **Do not attempt to derate by valve outlet pressure adjustment if the heater is factory equipped for high altitude. Do not attempt to adjust manifold pressure on heaters equipped with two stage gas valves.**
2. Determine the required valve outlet (manifold) pressure for the elevation where the heater will be operating. If unsure of the elevation, contact the local gas supplier.

| High Fire Valve Outlet (Manifold) Pressure by Elevation | | | |
|---|-----------|---------------|---------------|
| Altitude | | Natural Gas | Propane |
| Feet | Meters | (inches W.C.) | (inches W.C.) |
| 0- 2000 | 0-610 | 3.5 | 10.0 |
| 2001-3000 | 611-915 | 2.8 | 7.7 |
| 3001-4000 | 916-1220 | 2.5 | 7.1 |
| 4001-5000 | 1221-1525 | 2.3 | 6.4 |
| 5001-6000 | 1526-1830 | 2.1 | 5.8 |
| 6001-7000 | 1831-2135 | 1.9 | 5.2 |
| 7001-8000 | 2136-2440 | 1.7 | 4.6 |
| 8001-9000 | 2441-2745 | 1.5 | 4.1 |

6. Mechanical (cont'd)

6.1 Gas Piping and Pressures (cont'd)

6.1.2 Manifold or Orifice Pressure Settings (cont'd)

3. With the manual valve positioned to prevent flow to the main burners, connect a manometer to the 1/8" pipe outlet pressure tap in the valve. Use a fluid-filled manometer that is readable to the nearest tenth of an inch w.c.
4. Remove the cap from the pressure adjusting screw and adjust the manifold pressure to the pressure setting selected from the table. Cycle the main burners once or twice to properly seat the adjustment spring in the valve.
Re-check the pressure. If necessary, re-adjust the pressure. When the pressure is correct, remove the manometer and replace the cap. Check for leaks at the pressure tap fitting.
5. With the heater operating determine that the inlet pressure to the heater for natural gas is between 5 and 14 inches w.c. and for propane between 10 and 14 inches w.c. Take this reading as close as possible to heater (Most heaters are now equipped with gas valves that have an inlet pressure tap.) ***If the inlet pressure is not within the specified range, the inlet pressure must be corrected and Steps 3 and 4 repeated.***
6. Find the High Altitude Adjustment label in the plastic bag that contained these instructions. Using a permanent marker, fill-in the pressure setting. Adhere the label on the heater near the gas valve so that it is conspicuous to someone servicing the valve and/or the heater.

6.2 Venting

DANGER: Failure to provide proper venting could result in death, serious injury, and/or property damage. This heater must be installed with a vent connection and proper vent to the outside of the building. Install vent in accordance with Part 7, Venting of Equipment, of the National Fuel Gas Code, ANSI Z223.1 (latest edition) or applicable provision of national, state or local codes. A Canadian installation must be in accordance with the CSA B149.1 and B149.2, Installation Code for Gas Burning Appliances and Equipment, and applicable local codes. Also, follow venting recommendations listed below. Safe operation of any gravity-vented gas equipment requires a properly operating vent system, correct provision for the combustion air (See Paragraphs 2.2 and 4.1) and regular maintenance and inspection. See Hazard Levels, page 2.

6.2.1 Vent Outlet Sizes

Heaters have the following vent outlet sizes:

| Model Size | Size Configuration of Horizontal/ Vertical Vent Outlet |
|------------|--|
| 25 - 50 | 4" Round |
| 75 | 5" Oval |
| 100 | 6" Oval |
| 125 | 7" Oval |
| 165 - 200 | 8" Oval |
| 250 - 300 | 10" Oval |
| 400 | 12" Oval |

NOTE: Standard units manufactured prior to 10/89 (Serial No. Date Code prior to AOJ) have a round fixed vertical vent outlet in the size listed. Units manufactured prior to 10/89 with Option BT1 have the horizontal/vertical vent outlet.

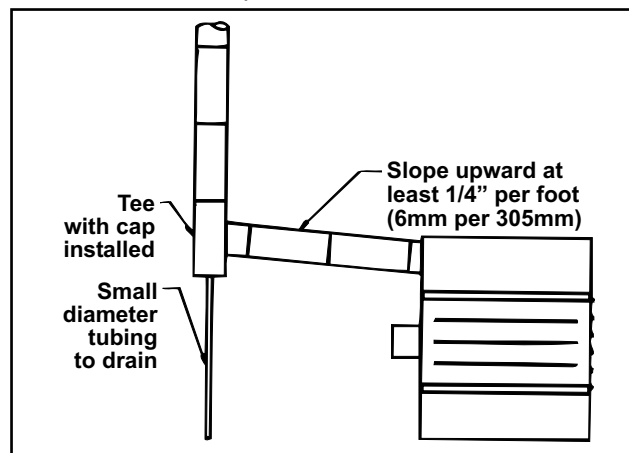
6.2.2 Venting Requirements - All Models

1. Provide a minimum clearance of 18" (457mm) between the drafthood relief opening and any obstruction. Do not expose the relief opening to wind drafts from any source such as from an overhead door or adjacent air handling equipment.
2. The unit is equipped with a built-in draft diverter, consequently an external draft diverter **MUST NOT** be installed in the vent connector or any internal alterations made. Do not install a manual damper or other fixed restriction in the vent connector.
A gravity-vented unit heater manufactured after August 7, 2008, **MUST** be installed with either an automatically controlled motorized vent damper (Option AV7) or power venting (Option CA).
3. Vent pipe should be a minimum of 26 gauge galvanized steel or other non-corrosive material. Double wall, Type B vent such as Metalbestos or Amerivent

is recommended. Where it is necessary to run the vent pipe through an exterior wall of combustible materials, a suitable thimble must be used. The vent pipe shall have a clearance of at least six inches (152mm) from combustible materials, or as is specified by the double-wall vent pipe manufacturer.

4. With the outlet on the heater in the horizontal position, it is recommended that a 12-18" (305-457mm) piece of straight pipe be connected to the flue collar before installing an elbow. The horizontal vent pipe run should have a uniform rise of at least 1/4" per foot (6mm per 305mm) of horizontal run in the direction of discharge. The length of the lateral run must not exceed lengths showing in the vent tables of the National Fuel Gas Code or the Canadian Installation Code for Gas Burning Appliances. (See Vent Table on page 18.)
5. Lateral runs should be supported every six feet (1.8M) using a non-combustible material, such as strap steel or chain. Do not rely on the draft hood or heater for support of either horizontal or vertical vent pipe.
6. Vent connectors serving Category I heaters shall not be connected into any portion of a mechanical draft system operating under positive pressure.
7. Where it is necessary to use a long run of vent pipe, or where the vent pipe is exposed to cold air, condensation within the pipe may occur. There are two ways to overcome or eliminate this problem.
 - (a) Prevent condensation by insulating the pipe so that the temperature of the flue products never drops below 250°F.
 - (b) Use double-wall, Type B vent pipe which is recommended for the reduction or elimination of condensate problems. Where extreme conditions are present and condensate is anticipated, install a drain for condensate. (See **FIGURE 13.**)

FIGURE 13 - Vent with Condensate Drain



8. The vent connection may be made into a suitable permanent chimney or into a gas vent. The effective area of the vent connector, gas vent or chimney when connected to a single appliance shall not be less than the area of the appliance draft hood outlet or in accordance with approved venting methods. The effective area of the gas vent or chimney when connected to more than one appliance shall not be less than the area of the largest vent connector plus 50% of the areas of additional vent connectors or in accordance with approved venting methods. Minimum permissible height of the vertical vent is five feet (1.5M) providing no horizontal vent pipe connector is used. If a horizontal vent connector is necessary, consult Vent Run Length Tables on page 18 or the National Fuel Gas Code or the Canadian Installation Code for Gas Burning Appliances, for the maximum permissible length of a horizontal pipe run (vent connector) for a given vertical height of gas vent. The gas vent or chimney should extend at least three feet (1M) above the highest point where it passes through a roof of a building and at least two feet (.6M) higher than any portion of a building or obstruction within a horizontal distance of ten feet (3M). Terminate the vent pipe with a Reznor Option CC1 vent cap. (**NOTE:** When installing a Size 125, run the required 7" vent pipe and use a field-supplied increaser to attach an 8" vent cap.) See illustrations in **FIGURES 14, 15, and 16.**

6. Mechanical (cont'd)

6.2 Venting (cont'd)

6.2.2 Venting Requirements (cont'd)

9. If the unit heater is installed in a space served by a large exhaust fan, be sure that the exhaust fan does not affect the operation of the heater or the satisfactory venting of its products of combustion.

If a negative pressure exists, as evidenced by a downdraft, a factory-designed mechanical motor driven venter (Option CA) should be installed. (The addition of a power venter allows for horizontal venting and alters the venting requirements including the vent pipe size and length. For additional installation information on an optional power venter, refer to Paragraph 6.2.4. Complete information is included in the venter package.)

In severe negative pressure conditions, makeup air equipment may be necessary.

FIGURE 14 - Venting Arrangement with Vent Run and through a Ceiling

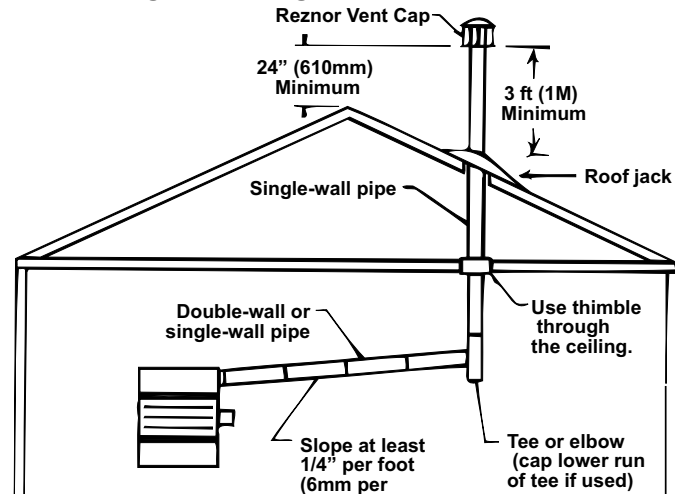


FIGURE 15 - Venting Arrangement with Vent Run (no ceiling)

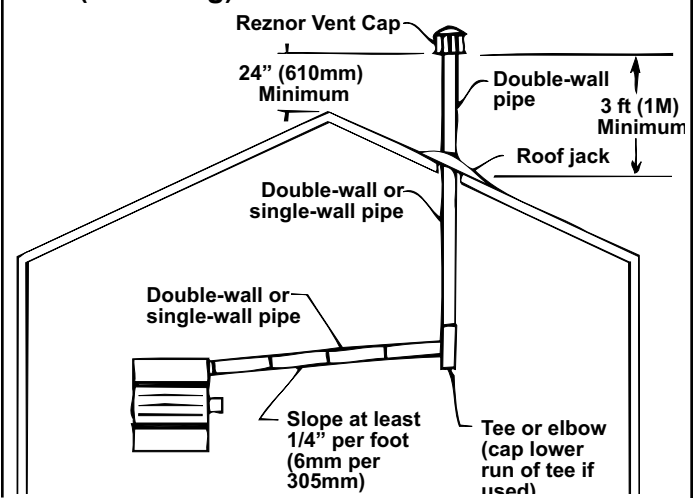
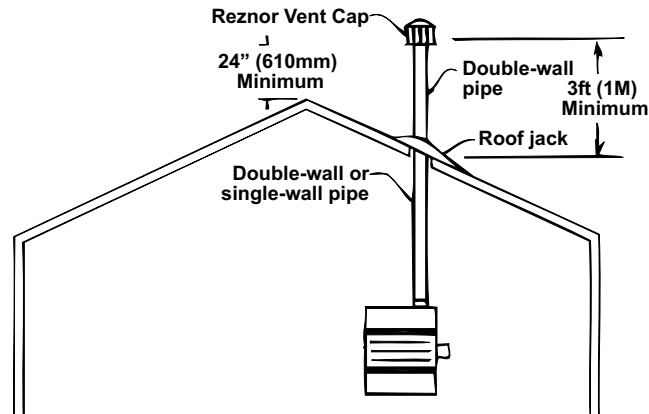


FIGURE 16 - Venting Arrangement without Vent Run



Vent Run Length Table

| Model Sizes | 25/50 | 75 | 100 | 125 | 165/200 | 250/300 | 400 |
|---|---------------|------------|-------------|-------------|-------------|-------------|-------------|
| Vertical Height of Vent | Vent Diameter | | | | | | |
| | 4" | 5" | 6" | 7" | 8" | 10" | 12" |
| Maximum Horizontal Run Length using Double Wall Type B Connector and Double-Wall Type B Vent | | | | | | | |
| 7 ft (2.1M) | 2 ft .6M | 6 ft 1.8M | 6 ft 1.8M | 6 ft 1.8M | 6 ft 1.8M | 6 ft 1.8M | 6 ft 1.8M |
| 9 ft (2.7M) | 6 ft 1.8M | 6 ft 1.8M | 7 ft 2.1M | 16 ft 4.9M | 16 ft 4.9M | 16 ft 4.9M | 16 ft 4.9M |
| 10 ft (3M) | 8 ft 2.4M | 10 ft 3M | 16 ft 4.9M | 20 ft 6.1M | 20 ft 6.1M | 20 ft 6.1M | 20 ft 6.1M |
| 15 ft (4.6M) | 12 ft 3.7M | 16 ft 4.9M | 16 ft 4.9M | 30 ft 9.1M | 30 ft 9.1M | 30 ft 9.1M | 30 ft 9.1M |
| 20 ft (6.1M) | 16 ft 4.9M | 20 ft 6.1M | 30 ft 9.1M | 30 ft 9.1M | 30 ft 9.1M | 30 ft 9.1M | 30 ft 9.1M |
| 30 ft (9.1M) | 18 ft 5.5M | 20 ft 6.1M | 40 ft 12.2M | 40 ft 12.2M | 40 ft 12.2M | 40 ft 12.2M | 40 ft 12.2M |
| Maximum Horizontal Run Length using Single Wall Metal Pipe | | | | | | | |
| 6 ft (1.8M) | 2 ft .6M | 2 ft .6M | 2 ft .6M | 2 ft .6M | 2 ft .6M | 2 ft .6M | 2 ft .6M |
| 8 ft (2.4M) | 2 ft .6M | 5 ft 1.5M | 5 ft 1.5M | 10 ft 3M | 10 ft 3M | 10 ft 3M | 10 ft 3M |
| 10 ft (3M) | 2 ft .6M | 5 ft 1.5M | 10 ft 3M | 15 ft 4.6M | 15 ft 4.6M | 15 ft 4.6M | 15 ft 4.6M |
| 15 ft (4.6M) | 2 ft .6M | 5 ft 1.5M | 10 ft 3M | 15 ft 4.6M | 20 ft 6.1M | 20 ft 6.1M | 20 ft 6.1M |
| 20 ft (6.1M) | N.R. | | 10 ft 3M | 15 ft 4.6M | 20 ft 6.1M | 20 ft 6.1M | 20 ft 6.1M |

6.2.3 Vent Control Damper, Option AV7

NOTE: A gravity-vented unit heater manufactured after August 7, 2008, MUST be installed with either an automatically controlled motorized vent damper (Option AV7) or power venting (Option CA).

The vent damper option is a motorized damper that will close when the heater is not operating. The vent damper is applicable only with spark ignition with lockout (Control Option AH3). See **NOTES** below and follow the manufacturer's instructions to install it in the vent. See the wiring diagram on the heater to make the wiring connections.

NOTES: The wiring harness with the vent damper is 8 ft (2.4M) in length. The vent damper should be located as close to the heater as possible and cannot be more than 8 ft (2.4M) from the ignition controller. The ignition controller has a safety feature that once it is used with a vent damper, it will no longer operate a unit without a vent damper.

FIGURE 17 - Option AV7, Vent Control Damper



6.2.4 Optional Power Venting - Option CA

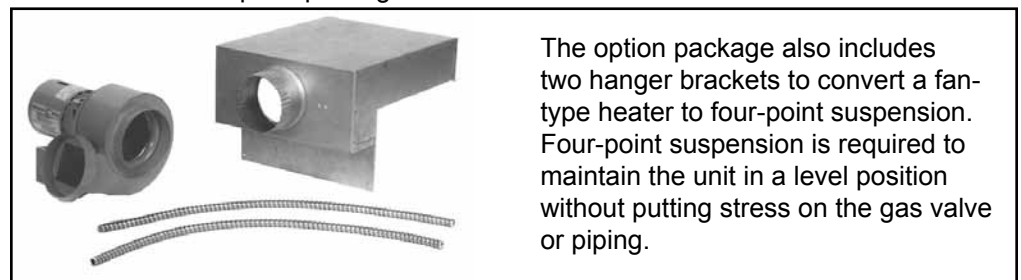
NOTE: Do not install an Option CA venter on a heater equipped with voltage option AK11, 220-240/1/50 Hertz.

Option CA is a motorized vent exhauster that is designed to permit the operation of these gravity-vented heaters in areas of negative pressure up to 0.15" w.c. or where horizontal venting is required.

The option package includes complete installation and wiring instructions. The venter is wired so that when the thermostat calls for heat, the thermostat contacts close the circuit which, after a delay of approximately 30 seconds, starts the venter. When the venter starts, air from the venter blower closes an air flow switch that is built into the venter. The closing of the air flow switch completes the electric circuit to the burner controls, opening the gas valve. When the thermostat is satisfied, the thermostat closes the gas valve and de-energizes the time delay relay. Approximately 45 seconds after the thermostat is satisfied, the air flow switch resets to the open position.

The addition of the optional power venter changes the vent size requirements of the heater. The vent sizes and allowable vent lengths are listed in the installation instructions in the option package.

FIGURE 18 - Venter Assembly and Adapter



The option package also includes two hanger brackets to convert a fan-type heater to four-point suspension. Four-point suspension is required to maintain the unit in a level position without putting stress on the gas valve or piping.

6.3 Inlet Air - Blower Model B

6.3.1 Optional Blower/Filter Cabinet - Options CW1, CW2, or CW3 (Blower Models Only)

The blower/filter cabinet option is available for all Model B sizes. The blower/filter cabinet is shipped separately for field assembly and installation. The cabinet is adaptable for use with either 1" or 2" filters and may be connected to a return air duct (includes 3/4" duct flange). Option CW1 does not include filters; CW2 includes 1" permanent aluminum filters; and CW3 includes 2" permanent aluminum filters.

Follow the illustrated instructions included with the option package.

FIGURE 19 - Optional Field-Installed Blower/Filter Cabinet

Blower Cabinet without filters (Option CW1)

Blower Cabinet with Filters (Option CW2 or CW3) -- side panel removed to illustrate interior of cabinet

| Model Size | Qty | Filter Size | Replacement P/N | |
|------------|-----|-------------|-----------------|-----------|
| | | | 1" Filter | 2" Filter |
| 25-125 | 1 | 20 x 20 | 101608 | 101621 |
| | 1 | 16 x 25 | 101609 | 101622 |
| 165-200 | 1 | 20 x 25 | 101610 | 101623 |
| | 2 | 16 x 20 | 101607 | 101620 |
| 250-300 | 2 | 20 x 20 | 101608 | 101621 |
| | 2 | 16 x 25 | 101609 | 101622 |
| 400 | 2 | 20 x 25 | 101610 | 101623 |

6. Mechanical

6.4 Unit Discharge

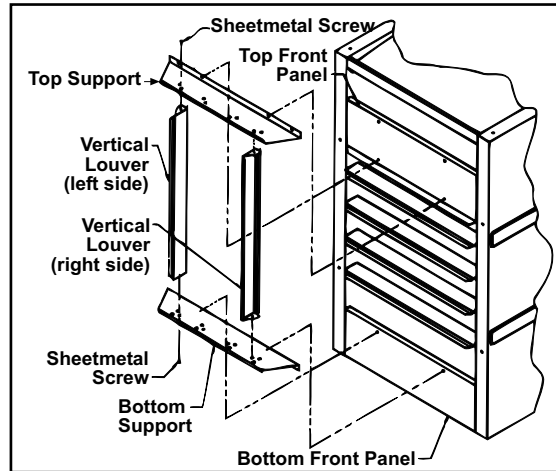
6.4.1 Vertical Louvers, Option CD1 - Apply to F and B

FIGURE 20 - Optional Vertical Louvers

CAUTION: To avoid getting burned, adjust louvers prior to heater operation. If louvers need re-adjusting after start-up, wear protective gloves.

All fan type Model F heaters are factory equipped with horizontal louvers. Depending on how it was ordered, a blower-type Model B heater may be factory equipped with either horizontal louvers or a duct flange.

There are also field installed outlet options that may have been ordered. These options are shipped separately and include installation instructions; see Paragraphs below for a brief description.



The purpose of the addition of optional vertical louvers is to increase the air pattern spread. The vertical louver assembly is designed to be field assembled and installed.

Refer to the instructions packaged with Option CD1 for a list of components and step-by-step installation instructions. (Do not add optional vertical louvers to a fan-type heater with downturn nozzle Option CD3.)

6.4.2 Downturn Air Nozzles, Options CD2, CD3, CD4, and CD5 - Applies to Model F and B as listed

Unit heaters may be specified with optional downturn air nozzles to direct the discharge tempered air. The nozzles are shipped separately for field assembly and installation. The horizontal louvers are removed from the heater and re-installed into the outlet of the downturn nozzle.

The addition of a downturn nozzle requires four-point heater suspension. Two hanger brackets are included with downturn nozzle options and must be added to fan-type heaters with standard two-point suspension. Suspension point dimensions are found in Dimension Charts in Paragraph 4.2. On fan-type heaters, do not install Option CD5 or use vertical louvers with Option CD3.

FIGURE 21 - Optional Downturn Nozzles

| Option CD2 Nozzle and CD4 Nozzle with Vertical Louvers | | |
|--|-------------|-------------------------|
| Sizes | "A" | Range of Air Deflection |
| 25-125 | 9" (229mm) | 25°-65° |
| 165-400 | 13" (330mm) | 25°-65° |

| Option CD3 Nozzle and CD5 Nozzle with Vertical Louvers (NOTE: CD5 applies to Model B only.) | | |
|--|-----------------|-------------------------|
| Sizes | "A" | Range of Air Deflection |
| 25-125 | 6-1/2" (419mm) | 50°-90° |
| 165-400 | 23-1/2" (597mm) | 50°-90° |

6.4.3 Field-Installed Duct Flange, Option CD9 - applies to Model B only

Blower-type unit heaters may be connected to ductwork. The duct flange option is designed to adapt the heater outlet (supply side) for connection to ductwork.

Ductwork connection sizes are shown in the chart below.

Follow the installation instructions included with the option package.

| Duct Connection Sizes with Optional Duct Flange | | | | | | | | | |
|---|--------|--------|--------|--------|--------|--------|--------|---------|--------|
| Model B Size | | 25-50 | 75 | 100 | 125 | 165 | 200 | 250-300 | 400 |
| Height | inches | 15-7/8 | 15-7/8 | 15-7/8 | 15-7/8 | 23-7/8 | 23-7/8 | 23-7/8 | 23-7/8 |
| | mm | 403 | 403 | 403 | 403 | 606 | 606 | 606 | 606 |
| Width | inches | 10-3/4 | 12-3/4 | 14-3/4 | 20-1/2 | 17-1/2 | 20-1/2 | 26 | 34-1/4 |
| | mm | 273 | 324 | 375 | 521 | 445 | 521 | 660 | 870 |

CAUTION: An external duct system static pressure not within the limits shown on the rating plate or improper adjustment of the motor pulley or belt may overload the motor and/or damage the heat exchanger.

6.4.4 Polytube Adapter - Options CD6, CD8, and CD11 - applies to Model B only

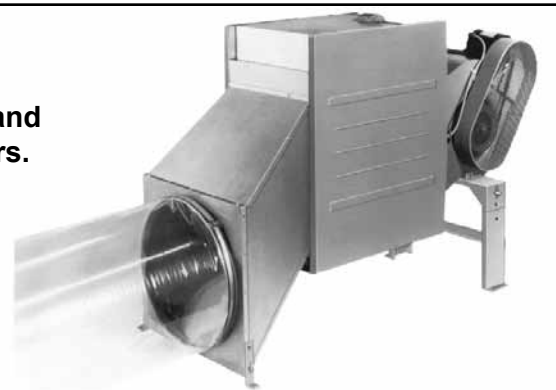
The polytube adapter option is designed to adapt this blower-type heater for use with polytube ductwork. The use of polytubes for air distribution is common in greenhouse applications and some industrial applications. A polytube distribution system delivers warm air to a specific area, reducing the need for complete area heating. The polytube adapter is available in three installation designs making it adaptable to many applications and building structures.

WARNINGS: This adapter is to be used only on blower units. At no time should the free area in the polytube be less than the listed minimum. Failure to comply with these warnings could result in severe personal injury, death and/or property damage.

The polytube adapter option package does not include polytubing. Poly tubing can be obtained from a supply distributor such as MVT-USA Company, 150 Elizabeth Lane, Unit 1, Genoa City, WI 53128 or from most local greenhouse supply distributors. Some local code authorities require the polytube material to be a listed material. Consult code authority having jurisdiction and the polytube supplier to determine the appropriate polytube material and recommended methods of suspension.

FIGURE 22 - Optional Polytube Adapter

Illustration shows Option CD8, Polytube Adapter for Floor-Mounted Heater. Options CD6 and CD11 are for Suspended Heaters.



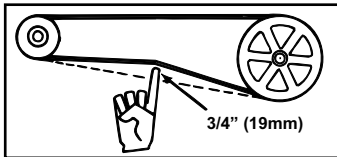
| Conversion Table (Diameter to Area) | |
|--|-----------------------------|
| Diameter of the Hole (inches) | Area of the Hole (sq in) |
| 2-1/2 | 4.91 |
| 2-1/4 | 3.98 |
| 2 | 3.14 |
| 1-7/8 | 2.76 |
| 1-1/2 | 1.76 |
| 1 | 0.785 |

| Size | CFM at .25" ESP | Polytube Diameter (inches) | Minimum Free Area (square Inches) | Holes | Suggested Hole Sizes and Locations | | | | |
|------|-----------------|----------------------------|-----------------------------------|----------|------------------------------------|----------|-----------|-----------|-----------|
| | | | | | Length of Polytube | | | | |
| | | | | | 50 Ft | 75 Ft | 100 Ft | 125 Ft | 150 Ft |
| 75 | 925 | 18 | 110 | Number | 37 pairs | 75 pairs | 75 pairs | | |
| | | | | Diameter | 1-1/2" | 1" | 1" | | |
| | | | | Spacing | 16" | 12" | 16" | | |
| 100 | 1235 | 18 | 145 | Number | 50 pairs | 50 pairs | 100 pairs | 94 pairs | |
| | | | | Diameter | 1-1/2" | 1-1/2" | 1" | 1" | |
| | | | | Spacing | 12" | 18" | 12" | 16" | |
| 125 | 1540 | 18 | 185 | Number | 40 pairs | 60 pairs | 60 pairs | 125 pairs | |
| | | | | Diameter | 1-7/8" | 1-1/2" | 1-1/2" | 1" | |
| | | | | Spacing | 15" | 15" | 20" | 12" | |
| 130 | 1600 | 24 | 190 | Number | 40 pairs | 60 pairs | 60 pairs | 125 pairs | |
| | | | | Diameter | 1-7/8" | 1-1/2" | 1-1/2" | 1" | |
| | | | | Spacing | 15" | 15" | 20" | 12" | |
| 165 | 2035 | 24 | 240 | Number | 50 pairs | 50 pairs | 75 pairs | 75 pairs | 75 pairs |
| | | | | Diameter | 1-7/8" | 1-7/8" | 1-1/2" | 1-1/2" | 1-1/2" |
| | | | | Spacing | 12" | 18" | 16" | 20" | 24" |
| 200 | 2465 | 24 | 300 | Number | 42 pairs | 42 pairs | 60 pairs | 60 pairs | 100 pairs |
| | | | | Diameter | 2-1/4" | 2-1/4" | 1-7/8" | 1-7/8" | 1-1/2" |
| | | | | Spacing | 14" | 21" | 20" | 25" | 18" |
| 250 | 3085 | 24 | 360 | Number | 40 pairs | 60 pairs | 60 pairs | 60 pairs | 60 pairs |
| | | | | Diameter | 2-1/2" | 2" | 2" | 2" | 2" |
| | | | | Spacing | 15" | 15" | 20" | 25" | 30" |
| 300 | 3700 | 24 | 425 | Number | 75 pairs | 75 pairs | 75 pairs | 75 pairs | 75 pairs |
| | | | | Diameter | 2" | 2" | 2" | 2" | 2" |
| | | | | Spacing | 9" | 12" | 16" | 20" | 24" |
| 400 | 4935 | 24 | 550 | Number | 60 pairs | 60 pairs | 60 pairs | 100 pairs | 100 pairs |
| | | | | Diameter | 2-1/2" | 2-1/2" | 2-1/2" | 1-7/8" | 1-7/8" |
| | | | | Spacing | 10" | 15" | 20" | 15" | 18" |

6. Mechanical (cont'd) 6.5 Fan, Blower, and Drive

6.5.2 Belt Tension and Blower Operation - Model B

FIGURE 23 - Adjusting Belt Tension



6.5.1 Fan Operation - Model F

The fan motor is equipped with thermal overload protection of the automatic reset type. Should the motor refuse to run, it may be because of improper current characteristics. Make certain that the correct voltage is available at the motor.

Blower Model **Sizes 25-100** are standardly equipped with a direct drive motor; an optional belt drive motor is available on Sizes 50-100. Blower Model **Sizes 125-400** have an adjustable belt drive motor.

As part of the Check/Test/Start (Paragraph 9), check the belt for proper tension and check that the setscrews are tight to the shaft.

Proper belt tension is important to the long life of the belt and motor. A loose belt will cause wear and slippage. Too much tension will cause excessive motor and blower bearing wear. Adjust the belt tension by turning the adjusting screw on the motor base until the belt can be depressed 1/2-3/4" (13-19mm). (See **FIGURE 23**.) After correct tension is achieved, re-tighten the locknut on the adjusting screw.

Most blower motors are equipped with thermal overload protection of the automatic reset type. If a motor is not equipped with thermal overload protection, the unit will be equipped with a starter. The adjustable setting on the starter will be factory set to match the amp draw of the motor and sealed. No change should be made to starter set unless the original motor is replaced.

Starters are supplied from the factory for manual reset operation. If an overload condition is experienced, the condition must be corrected, and the starter must be manually reset.

After the installation is complete including all ductwork, check the amp draw of the motor with an amp meter to verify that the motor amp rating on the motor nameplate is not being exceeded. Amps may be adjusted downward by reducing blower speed or by increasing the duct system static pressure. The temperature rise must be within the range specified on the unit rating plate.

Blower Speed Adjustment

The blower speed may be adjusted to achieve the desired outlet temperature, as long as the adjustment is within the temperature rise and the static pressure limits shown on the heater rating plate. **Direct drive motors** are factory set as indicated in the chart below. **Belt drive motors** are factory set at the midpoint between maximum and minimum blower speeds.

If the duct resistance is low, the blower may deliver too high an air volume; or if the heater is operated without ductwork, it may deliver sufficient excess air to overload the motor, causing the overload protector to cycle the motor. Reducing the blower speed will correct these conditions. If ductwork is added to an installation, it may be necessary to increase the blower speed. Decreasing blower speed will increase outlet temperature; increasing blower speed will decrease outlet temperature.

Blower Model Sizes 25-100 with Direct Drive

Direct drive blower motors have multi-speed taps for speed adjustment. If your installation requires an adjustment of the blower speed, the motor may be re-wired to an alternate tap by following these instructions.

1. Turn off the gas and the electric power.
2. Remove the left (left when facing the back of the unit) outer side panel of the heater to reveal the wiring connections.
3. Consult the wiring diagram on the heater and follow the chart on the right to choose the wire connections for the desired adjustment.

The asterisk(*) indicates the factory-wired speed.

| Size | Speed | Use these Two Motor Wires |
|------|---------|---------------------------|
| 25 | *Medium | *Blue and White |
| | Low | Red and White |
| 50 | *High | *Black and White |
| | Medium | Blue and White |
| 75 | High | Black and White |
| | *Medium | *Blue and White |
| | Low | Red and White |
| 100 | *High | *Black and White |
| | Medium | Blue and White |
| | Low | Red and White |

4. Cut the crimped cap from the end of the wire that you intend to use and strip the insulation.
5. Disconnect the factory-wired connection and re-wire, using the newly stripped wire.
6. Put a wire nut on the end of the blower motor wire that was disconnected.
7. Replace the heater side panel and turn on the gas and the electric.

Blower Model Sizes 50-400 with Belt Drive

The belt drive on these units is equipped with an adjustable pulley which permits adjustment of the blower speed. Follow these instructions to adjust the blower speed.

1. Turn off the gas and the electric power.
2. Loosen belt tension and remove the belt.
3. Loosen the set screw on the side of the pulley away from the motor.
4. **To increase the blower speed, decreasing outlet temperature**, turn the adjustable half of the pulley inward. **To decrease the blower speed, increasing the outlet temperature**, turn the adjustable half of the pulley outward. One turn of the pulley will change the speed 8-10%.
5. Tighten the set screw on the flat portion of the pulley shaft.
6. Replace the belt and adjust the belt tension. Adjust tension by turning the adjusting screw on the motor base until the belt can be depressed 1/2-3/4" (13-19mm). (See **FIGURE 23.**) Re-tighten the lock nut on the adjusting screw.
7. Turn on the gas and electric. Light the heater following the instructions on the lighting instruction plate.
8. Check the motor amps with an amp meter. The maximum motor amp rating on the motor nameplate must not be exceeded.

CAUTION: An external duct system static pressure not within the limits shown on the rating plate or improper adjustment of the motor pulley or belt may overload the motor and/or damage the heat exchanger.

Blower Rotation

Each blower housing is marked for proper rotation. Rotation may be changed on single-phase motors by re-wiring in the motor terminal box. Three-phase motors may be reversed by interchanging two wires on the 3-phase supply connections.

7. Electrical Supply and Wiring

7.2 Supply Voltage and Wiring

7.1 General

All electrical wiring and connections, including electrical grounding **MUST** be made in accordance with the National Electric Code ANSI/NFPA No. 70 (latest edition) or, in Canada, the Canadian Electrical Code, Part I-C.S.A. Standard C22.1. In addition, the installer should be aware of any local ordinances or gas company requirements that might apply.

Check the rating plate on the heater for the supply voltage and current requirements. A separate line voltage supply with fused disconnect switch should be run directly from the main electrical panel to the heater. All external wiring must be within approved conduit and have a minimum temperature rise of 60°C. Conduit from the disconnect switch must be run so as not to interfere with the service panels of the heater.

The electrical supply connects at the top back of the heater in the left corner (left when facing the back of the heater). A threaded hole is provided for a standard 1/2" electrical fitting. See **FIGURE 24.** The wiring access panel is easily removed for field connections. Consult the wiring diagram supplied with your heater. Replace the panel after the wiring connections are made.

If the heater has field-installed options that require electrical connections, consult the instruction sheet and wiring diagram supplied in the option package.

A fan-type heater may be equipped with a built-in fused disconnect switch (Option AI-1). If the heater is equipped with a built-in disconnect switch, a two-position toggle (on/off) switch is located near the electrical supply access panel (See **FIGURES 24**

7. Electrical Supply and Wiring (cont'd)

7.2 Supply Voltage and Wiring (cont'd)

and 25). This switch may be used to disconnect the power when servicing the heater *other than* in the supply junction box.

WARNINGS: On a heater with a unit disconnect switch (Option AI-1), when the power is turned off at the unit-mounted switch, the supply lead in the electrical supply junction box (FIGURE 24) remains energized. If service is to be done in the supply junction box, turn off the power at the remote disconnect switch.

If you turn off the power supply, turn off the gas.

FIGURE 24 - Electrical Supply Connections

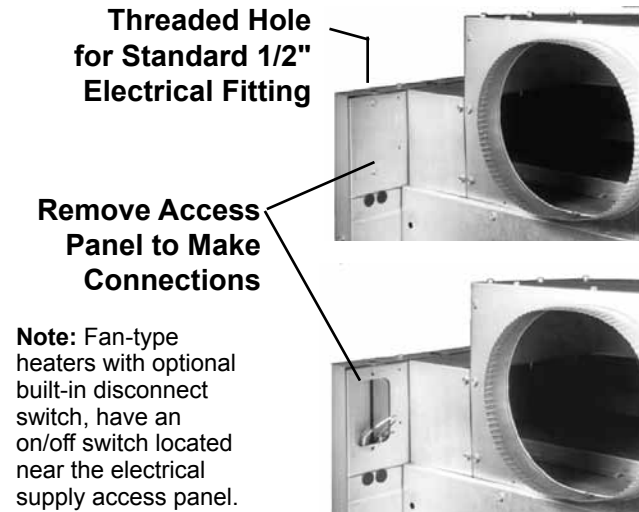
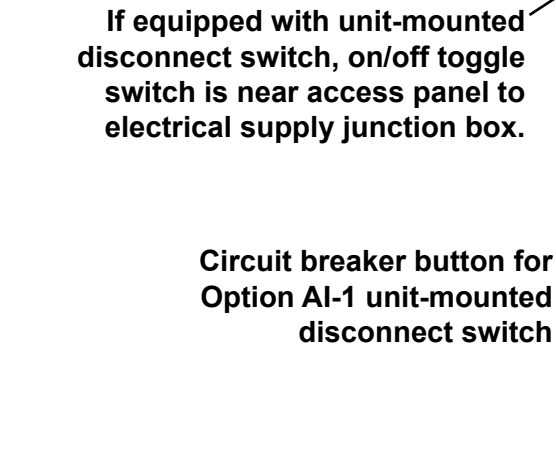


FIGURE 25 - Fan Model showing location of Optional Unit-Mounted Disconnect Switch and Reset Button



Specific wiring diagrams that include standard and factory-installed options are on with the heater. Check the wiring diagram to identify optional equipment.

The operating sequence of the heater can be found on the heater wiring diagram and is published in Paragraph 9, Check Installation and Start-Up. **Typical wiring diagrams are FIGURES 30-33** showing single-stage heating with intermittent spark pilot.

CAUTION: FAN-TYPE MODEL FOR OPTIONAL 50 HERTZ OPERATION

A fan-type heater with Option AK11 is designed for operation from a 220-240V/50Hz/single phase power source. Connection to any other voltage or frequency source may cause failure of the equipment and/or damage to persons or property.

In the event that this product is purchased or destined for export markets, the buyer is responsible for meeting any and all local codes covering installation and labeling of the product. The equipment as provided by the manufacturer is design-certified to ANSI Standard and comes with English-only labels and installation instructions.

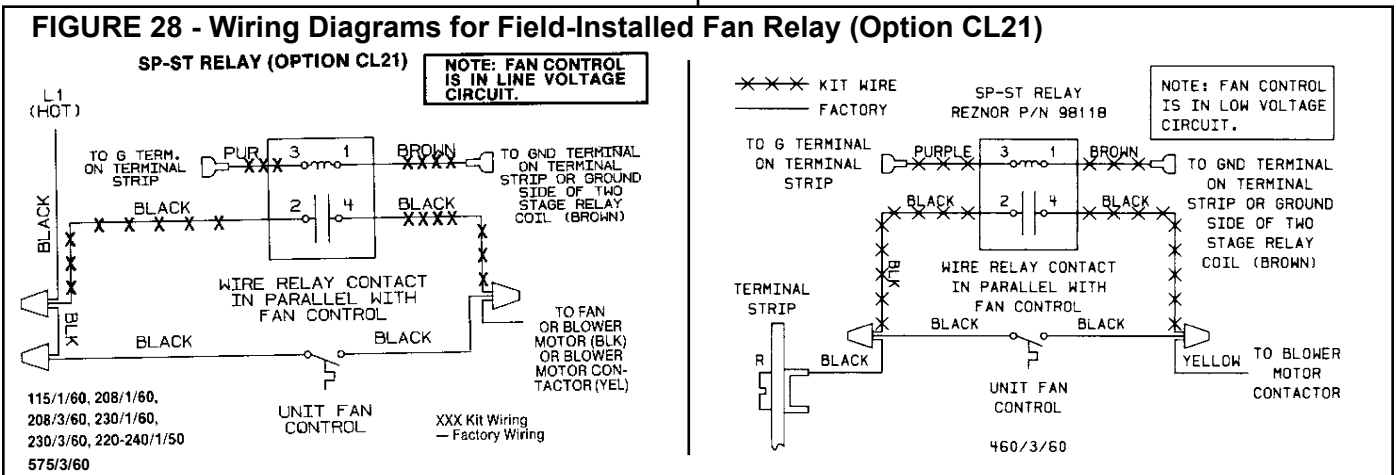
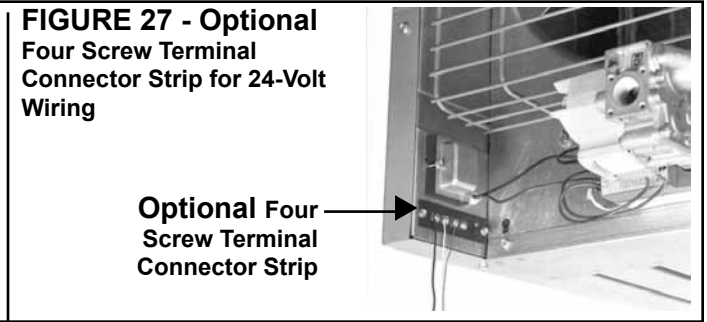
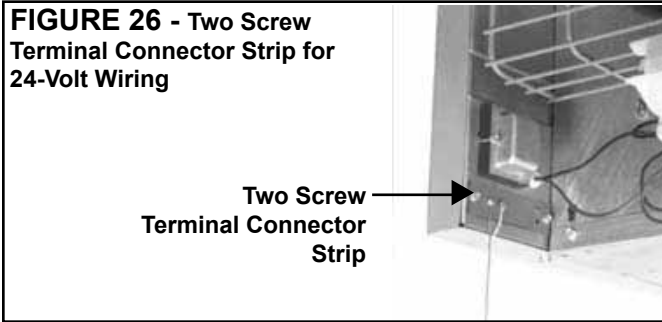
7.3 Control Wiring

A thermostat is not standard equipment but is an installation requirement. Use either an optional thermostat available with the heater or a field-supplied thermostat. Install according to the thermostat manufacturer's instructions. Make sure that the heat anticipator setting on the thermostat is in accordance with the amperage value noted on the wiring diagram of your heater.

Terminal Strip Connections - The standard heater is equipped with a two-screw terminal connector strip (See FIGURE 26) for easy connection to the low voltage controls (24V).

When factory-installed options require two-stage thermostat control, the heater is equipped with a SP-ST relay and a four-screw terminal connector strip (See **FIGURE 27**).

If your heater requires field installation of the four-screw terminal strip and the relay, follow the instructions packaged with the relay or thermostat option. **FIGURE 28** illustrates the wiring and the connections required for an optional field-installed fan relay.



Multiple Heater Control - These unit heaters are not designed for multiple unit connection to one thermostat. If you require that more than one unit be controlled by a single thermostat, it will be necessary to use relays in the circuit. Options CL31 and CL32 provide the necessary parts and instructions for multiple heater control.

The multiple heater control options are designed to permit the control of up to six heaters with a single thermostat or time clock and single/multiple thermostats. For maximum safety, the multiple control is in the low voltage circuit. These multiple heater control options may not be used with two-stage gas valves.

FIGURE 29 - Wiring Label for Multiple Heater Control Wiring with Options CL31 and/ or CL32

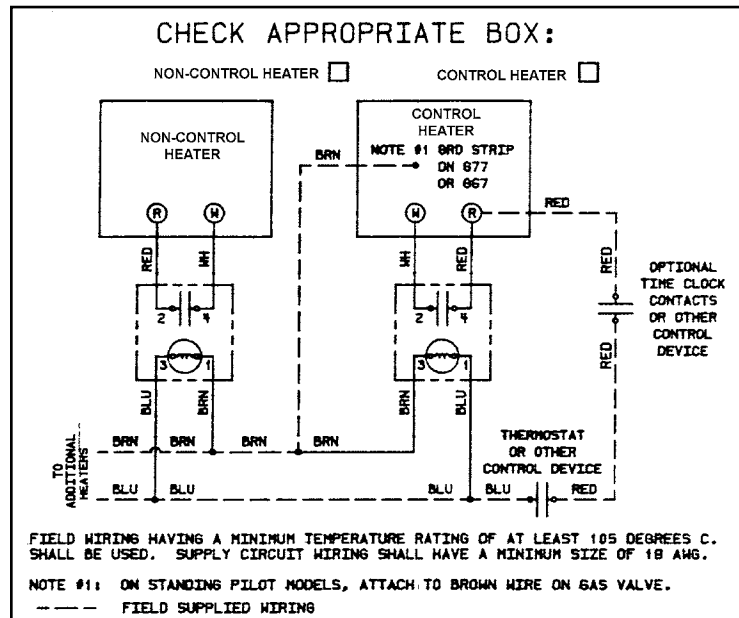


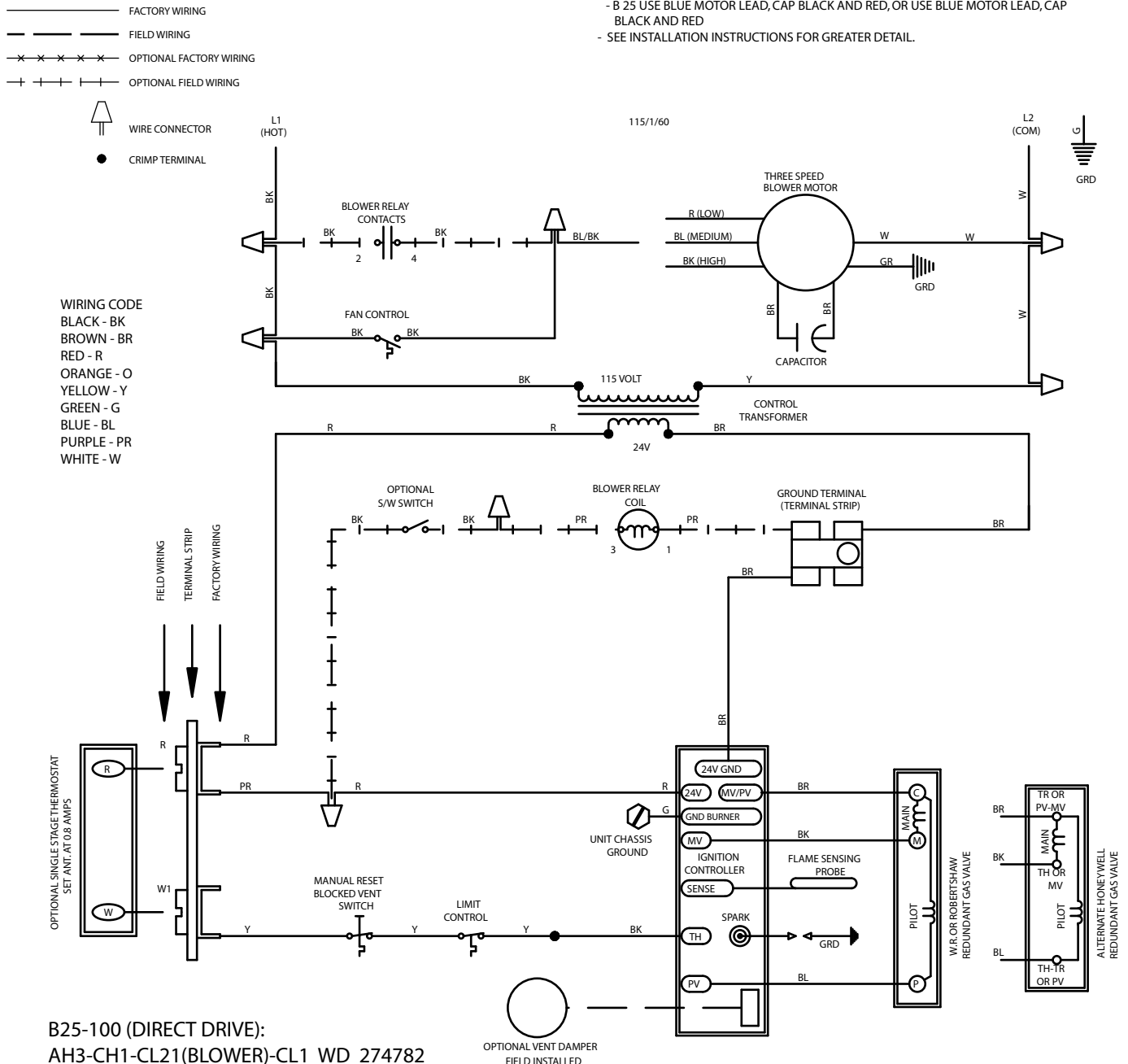
FIGURE 31 - Blower-type, Gravity-Vented, Model B Sizes 25-100 with Intermittent Spark Pilot, Single Stage Heating, Natural or Propane, Direct Drive

OPERATING SEQUENCE

- SET THERMOSTAT AT LOWEST SETTING.
- TURN ON MAIN AND PILOT MANUAL GAS VALVES.
- TURN ON POWER TO UNIT.
- SET THERMOSTAT AT DESIRED SETTING.
- THERMOSTAT CALLS FOR HEAT FIRING UNIT AT FULL RATE AFTER PILOT PROVING SEQUENCE.
- FAN CONTROL SENSES HEAT EXCHANGER TEMPERATURE, ENERGIZING THE BLOWER MOTOR.
- IF THE FLAME IS EXTINGUISHED DURING MAIN BURNER OPERATION, THE SAFETY SWITCH CLOSSES THE MAIN VALVE. IF THE PILOT IS NOT ESTABLISHED WITHIN 120 SEC. THE UNIT LOCKS OUT FOR ONE HOUR, UNLESS IT IS RESET BY INTERRUPTING POWER TO THE CONTROL CIRCUIT. (SEE LIGHTING INSTRUCTIONS)
- SET THERMOSTAT AT LOWEST SETTING FOR SHUTDOWN.

NOTES

- THE FOLLOWING CONTROLS ARE FIELD INSTALLED OPTIONS: THERMOSTAT, S/W SWITCH AND BLOWER RELAY
- THE FOLLOWING CONTROLS ARE FACTORY INSTALLED OPTIONS: NONE
- DOTTED WIRING INSTALLED BY OTHERS.
- CAUTION: IF ANY OF THE ORIGINAL WIRE AS SUPPLIED WITH THE APPLIANCE MUST BE REPLACED, IT MUST BE REPLACED WITH WIRING MATERIAL HAVING A TEMPERATURE RATING OF AT LEAST 105 DEGREES C., EXCEPT FOR SENSOR LEAD WIRE WHICH MUST BE 150 DEGREES C.
- USE #14 GA WIRE FOR BLOWER MOTOR CIRCUIT WIRING ON UNIT.
- USE #18 GA WIRE FOR ALL WIRING EXCEPT BLOWER MOTOR CIRCUIT.
- LINE AND BLOWER MOTOR BRANCH WIRE SIZES SHOULD BE OF A SIZE TO PREVENT VOLTAGE DROPS BEYOND 5% OF SUPPLY LINE VOLTAGE.
- THREE SPEED MOTOR CONNECTIONS ARE AS FOLLOWS:
 - B 100-75 USE BLACK MOTOR LEAD, CAP BLUE AND RED, OR USE BLUE MOTOR LEAD, CAP BLACK AND RED, OR USE RED MOTOR LEAD, CAP BLACK AND BLUE
 - B 50 USE BLACK MOTOR LEAD, CAP BLUE AND RED, OR USE BLUE MOTOR LEAD, CAP BLACK AND RED
 - B 25 USE BLUE MOTOR LEAD, CAP BLACK AND RED, OR USE BLUE MOTOR LEAD, CAP BLACK AND RED
- SEE INSTALLATION INSTRUCTIONS FOR GREATER DETAIL.



B25-100 (DIRECT DRIVE):
 AH3-CH1-CL21(BLOWER)-CL1 WD 274782

FIGURE 33 - Blower-type, Gravity-Vented, Model B Sizes 165-400 with Intermittent Spark Pilot, Single-stage Heating, Natural or Propane, Belt Drive, Blower Motor Contactor (Note: Motor contactor is standard on Sizes 300 and 400; Optional on other sizes.)

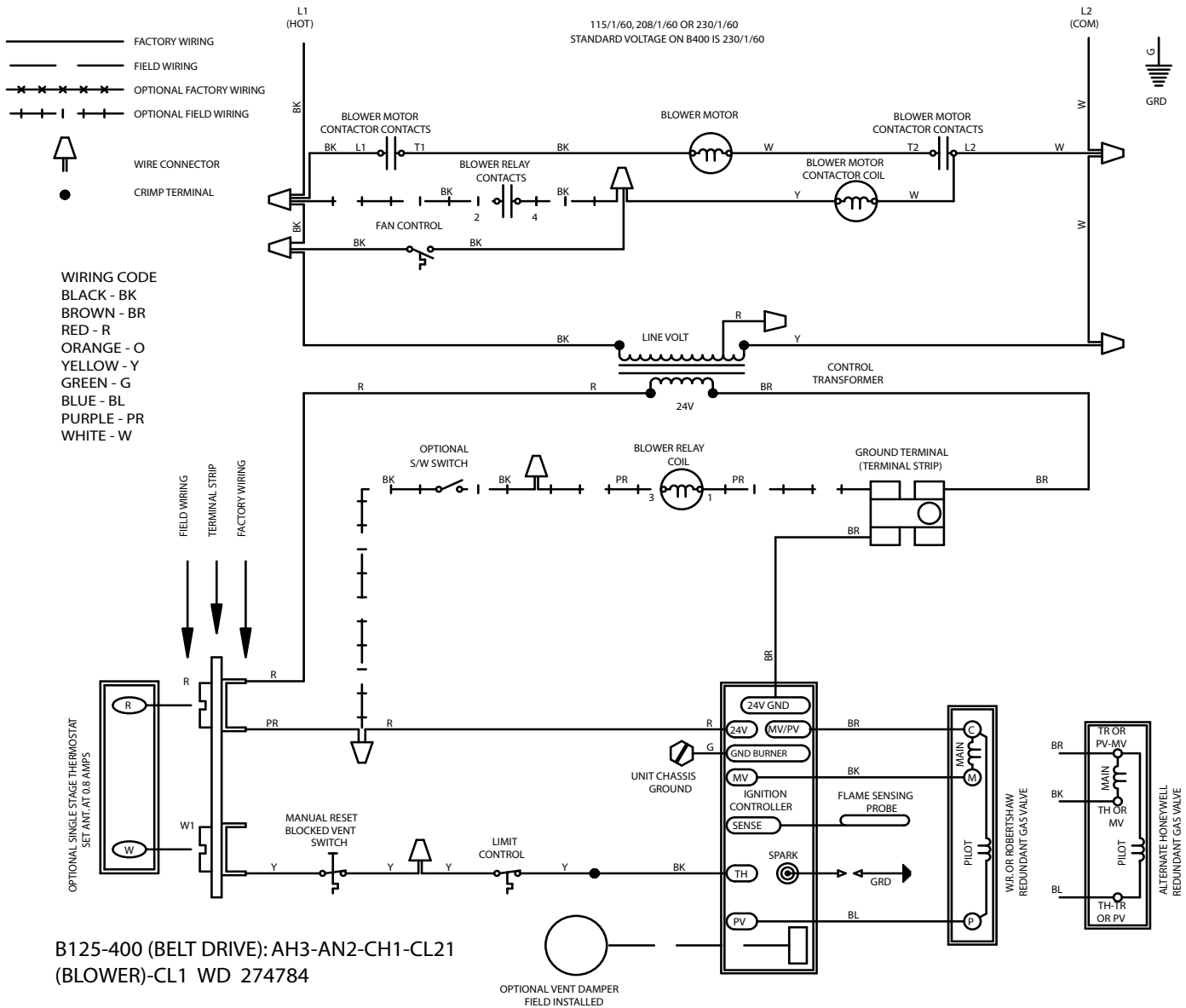
STANDARD DIAGRAM FOR B300 THRU 400
 DIAGRAM FOR B125 THRU 250 WITH OPTIONAL
 BLOWER MOTOR CONTACTOR

OPERATING SEQUENCE

- SET THERMOSTAT AT LOWEST SETTING.
- TURN ON MAIN AND PILOT MANUAL GAS VALVES.
- TURN ON POWER TO UNIT.
- SET THERMOSTAT AT DESIRED TEMPERATURE.
- THERMOSTAT CALLS FOR HEAT FIRING UNIT AT FULL RATE AFTER PILOT PROVING SEQUENCE.
- BLOWER OPERATES OFF THE HEAT EXCHANGER TEMPERATURE.
- IF THE FLAME IS EXTINGUISHED DURING MAIN BURNER OPERATION, THE SAFETY SWITCH CLOSSES THE MAIN VALVE. IF THE PILOT IS NOT ESTABLISHED WITHIN 120 SEC. THE UNIT LOCKS OUT FOR ONE HOUR, UNLESS IT IS RESET BY INTERRUPTING POWER TO THE CONTROL CIRCUIT. (SEE LIGHTING INSTRUCTIONS)
- SET THERMOSTAT AT LOWEST SETTING FOR SHUTDOWN.
- FOR CONTINUOUS BLOWER OPERATION SET S/W SWITCH AT "ON" POSITION.

NOTES

- THE FOLLOWING CONTROLS ARE FIELD INSTALLED OPTIONS: THERMOSTAT, S/W SWITCH AND BLOWER RELAY
- THE FOLLOWING CONTROLS ARE FACTORY INSTALLED OPTIONS: NONE
- DOTTED WIRING INSTALLED BY OTHERS.
- CAUTION: IF ANY OF THE ORIGINAL WIRE AS SUPPLIED WITH THE APPLIANCE MUST BE REPLACED, IT MUST BE REPLACED WITH WIRING MATERIAL HAVING A TEMPERATURE RATING OF AT LEAST 105 DEGREES C., EXCEPT FOR SENSOR LEAD WIRE WHICH MUST BE 150 DEGREES C.
- USE #14 GA WIRE FOR BLOWER MOTOR CIRCUIT WIRING ON UNIT.
- USE #18 GA WIRE FOR ALL WIRING EXCEPT BLOWER MOTOR CIRCUIT.
- LINE AND BLOWER MOTOR BRANCH WIRE SIZES SHOULD BE OF A SIZE TO PREVENT VOLTAGE DROPS BEYOND 5% OF SUPPLY LINE VOLTAGE.
- ON 230V. UNITS THE CONTROL TRANSFORMER HAS A DUAL VOLTAGE PRIMARY. FOR 230V. UNITS USE BLACK AND YELLOW LEADS (CAP RED).
- FOR 208V. UNITS USE BLACK AND RED LEADS (CAP YELLOW).
- ON 115V. UNITS THE CONTROL TRANSFORMER IS A SINGLE VOLTAGE PRIMARY. FOR 115V. UNITS USE BLACK AND YELLOW LEADS.
- SEE INSTALLATION INSTRUCTIONS FOR GREATER DETAIL.



8. Controls

8.1 Fan Control

1. A fan control provides the following:
 - (a) Delay of fan or blower operation to prevent the discharge of cold air.
 - (b) Fan or blower operation as long as the unit is hot.
2. The fan control provides additional safety by keeping the fan or blower in operation in the event that the gas valve fails to close when the thermostat is satisfied.
3. To be sure that the fan or blower can continue to operate, the power supply to the heater **MUST NOT** be interrupted except when servicing the unit.
4. If the customer wants the heater off at night, the gas valve circuit **SHOULD BE OPENED** by a single pole switch wired in series with the thermostat. Some thermostats are provided with this feature.
5. Multiple units controlled from a single thermostat are shut off in the same manner. For proper operation, be sure the fan control wiring is observed.

WARNING: If you turn off the power supply, turn off the gas. See Hazard Levels, page 2.

NOTE: Low ambient temperatures (less than 40°F) may cause false cycling of the fan/blower. To prevent this, a time delay relay can be added to the unit (available with single-stage gas valve only) to activate the fan/blower electrically independent of the heat exchanger or the room temperature. The low ambient fan control relay can be factory installed; Option BF8 will appear on the heater wiring diagram. Or, the relay can be field installed; order Option CQ3 (P/N 113779). This relay is in addition to the fan control **The fan control is a safety device and should never be removed from the heater circuit.**

8.2 Blocked Vent Switch

NOTE: Effective April 1991, all gravity vented unit heaters include a blocked vent shutoff system. Units manufactured prior to April 1991 do not include a blocked vent shutoff system.

The blocked vent switch is a heat-activated, manually reset, safety device that interrupts the electric supply to the gas valve when the vent is 100% blocked. The sensor is located near the relief opening of the draft hood. The switch is located on the front top of the draft hood.

If the sensor detects heated flue gases in the draft hood relief opening area, the blocked vent safety device will activate to shut down the heater. The cause for the switch shutting down the heater must be determined and corrected. The blocked vent switch is designed to activate when the vent is blocked but may also be affected by a negative building pressure or an inadequate vent system.

After the problem has been corrected, push the manual reset button on the blocked vent switch to restart the heater.

WARNING: In the event the blocked vent sensor causes the heater to shut off, determine and correct the cause. Failure to do so could result in personal injury or death.

8.3 Limit Control

All heaters are equipped with an automatic, non-adjustable reset limit control that acts to interrupt the electric supply to the redundant main operating valve in case of motor failure or lack of airflow due to restrictions at the inlet or outlet.

NOTE: Heaters with spark pilot manufactured prior to 8/99 also have an ECO control.

8.4 Gas Valve

Main operating valve is powered by the 24-volt control circuit through thermostat and safety controls. The main control valve is of the diaphragm type with magnetic pilot servo bleed operators, providing regulated gas flow preset at the factory. The valve body also incorporates a magnetic valve providing pilot gas control for the optional electronic ignitor system and redundant or dual valve safety shutoff function.

WARNING: The operating valve is the prime safety shutoff. All gas supply lines must be free of dirt or scale before connecting the unit to ensure positive closure. See Hazard Levels, page 2.

NOTES:

Natural gas units manufactured prior to 9/2007 may have Option AH2, which is a spark ignited intermittent safety pilot system with recycling pilot without lockout.

Units manufactured prior to 8/2008 may have a match-lit pilot.

8.5 Pilot and Ignition Systems

The pilot on Model F and B unit heaters is a spark ignited intermittent safety pilot system with lockout (Option AH3). The ignition controller in the spark pilot system provides the high voltage spark to ignite the pilot gas and also acts as the flame safety device. After ignition of the pilot gas, the control electronically senses the pilot flame. (A separate solid metal probe in the pilot burner assembly is employed for the flame sensing function. A low voltage electrical signal is imposed on that metal probe which is electrically isolated from ground. When the pilot flame impinges on the flame sensing probe, the flame acts as a conduction path to ground. The pilot flame rectifies and completes the DC circuit. The ignition controller acknowledges the flame and energizes the main gas valve.)

A lockout device stops the gas flow to the pilot if the pilot fails to light in 120 seconds. The spark pilot system with lockout has a 1-hour retry or requires manual reset by interruption of the thermostat circuit.

8.6 Burner Air Adjustment

Model F and B unit heaters have individually formed steel burners with accurately die-formed ports to give controlled flame stability without lifting or flashback with either natural or propane gas. The burners are lightweight and factory mounted in an assembly which permits them to be removed as a unit for inspection or service.

All sizes of Model F and B unit heaters that are equipped with standard aluminized burners are designed to operate without burner air shutters when fueled with either natural or propane gas. However, Sizes 165 through 400 equipped with optional stainless steel burners (Option AD2) require air shutters (Option AE1) when used with propane gas (Option AA2).

Optional air shutters, either factory or field installed, are available for any size model for use where unusual conditions cause excess primary aeration.

Before making any adjustments to the air shutters, allow the heater to operate for about fifteen minutes. The air shutter adjustment screws can be reached by opening the bottom panel. (Remove the two screws located at the rear of the bottom panel and allow the panel to hinge down from the front.) The adjustment screws for the air shutters are visible at the rear of the burner rack. See **FIGURE 34**.

When making the adjustment, close the air shutters no more than is necessary to eliminate the problem condition.

Observe the flame for yellow-tipping. A limited amount of yellow-tipping is permissible for liquefied petroleum gases. Other fuels should not display any yellow-tipping.

Two adjustment screws are used (See **FIGURE 34**). Rotating the screws clockwise closes the shutters, reducing the primary air supply. Counterclockwise rotation opens the shutters, increasing the primary air supply. The two adjustment screws should be rotated alternately to open or close the shutters. Attempting to gain adjustment by not alternating between the two screws may cause the shutters to bind.

After proper adjustment has been completed, eliminating the problem condition, close the bottom panel and replace the retaining screws.

FIGURE 34 - Air Shutter Adjustment Screws -- Alternate turning screws when adjusting shutter.

DANGER: Failure to install and/or adjust air shutters according to directions could cause property damage, personal injury, and or death.



9. Commissioning and Start-Up

9.1 Check the installation prior to start-up:

- Check suspension. Unit must be secure and level.
- Blower Model** - Check to be sure that all shipping supports have been removed. Rubber feet must be on the motor bracket bolts. See Paragraph 3.2.
- Check clearances from combustibles. Requirements are shown in Paragraph 4.1.
- Check vent system to be sure that it is installed according to the instructions in Paragraph 6.2.
- Check piping for leaks and proper gas line pressure. Bleed gas lines of trapped air. See paragraph 6.1
- Check electrical wiring. Be sure all wire gauges are as recommended. A service disconnect switch should be used. Verify that fusing or circuit breakers are adequate for the load use.
- Check that any field-installed options have been included in the installation.
- Blower Model** - Check belt tension. See Paragraph 6.5. Check the setscrews.

9.2 Start-Up

Typical Operating Sequence for Units with Optional Spark Pilot System with Timed Lockout:

1. Set the thermostat at its lowest setting.
2. Turn on the main and pilot manual gas valves.
3. Turn on the power to the unit.
4. Set the thermostat at the desired setting.
5. Thermostat calls for heat, firing the unit at full rate after pilot proving sequence.
6. Fan Control senses heat exchanger temperature, energizing the fan or blower motor.
7. If the flame is extinguished during the main burner operation, the safety switch closes the main valve and recycles the spark. If the pilot is not established within 120 seconds, the unit locks out and must be reset by interrupting the power to the control circuit. (See lighting instructions on the heater.)

9.3 Check installation after start-up:

- With the unit in operation, measure manifold gas pressure. See Paragraph 6.1.
- Turn the unit off and on, pausing two minutes between each cycle. Observe for smooth ignition.
- Check draft hood relief opening for positive pressure.
- Blower Model** - Check motor amps with an amp meter. The maximum amp rating on the motor nameplate must not be exceeded.
- Place "Literature Bag" containing Limited Warranty Card, this booklet, and any optional information in an accessible location near the heater. Follow the instructions on the bag.

DANGER: The gas burner in this gas-fired equipment is designed and equipped to provide safe, complete combustion. However, if the installation does not permit the burner to receive the proper supply of combustion air, complete combustion may not occur. The result is incomplete combustion which produces carbon monoxide, a poisonous gas that can cause death. Safe operation of indirect-fired gas burning equipment requires a properly operating vent system which vents all flue products to the outside atmosphere. FAILURE TO PROVIDE PROPER VENTING WILL RESULT IN A HEALTH HAZARD WHICH COULD CAUSE SERIOUS PERSONAL INJURY OR DEATH.

Always comply with the combustion air requirements in the installation codes and in Paragraphs 2.2 and 4.1. Combustion air at the burner should be regulated only by manufacturer-provided equipment. NEVER RESTRICT OR OTHERWISE ALTER THE SUPPLY OF COMBUSTION AIR TO ANY HEATER. Indoor units installed in a confined space must be supplied with air for combustion as required by Code and in Paragraph 2.2 of this manual. MAINTAIN THE VENT SYSTEM IN STRUCTURALLY SOUND AND PROPERLY OPERATING CONDITION.

10. Maintenance and Service

NOTE: Use only factory-authorized replacement parts.

10.1 Maintenance Schedule

WARNING: If you turn off the power supply, turn off the gas. See Hazard Levels, page 2.

This unit will operate with a minimum of maintenance. To ensure long life and satisfactory performance, a heater that is operated under normal conditions should be inspected and cleaned at the start of each heating season. If the heater is operating in an area where an unusual amount of dust or soot or other impurities are present in the air, more frequent maintenance is recommended.

The following procedures should be carried out at least annually (See Paragraphs 10.2.1-10.2.10 for specific instructions.):

- Clean all dirt and grease from the primary and secondary combustion air openings.
- Fan Models** - Clean the fan blade, fan guard, and motor.
- Blower Models** - Clean the blower, the belt guard, the inlet guard, and motor of all dirt and grease. Check the blower belt for tension and wear. Replace a worn belt that may fail before the next scheduled maintenance check. Check that setscrews are tight to the shaft.
- Check the gas valve to ensure that gas flow is being shutoff completely.
- Clean the heat exchanger both internally and externally.
- Check the pilot burner and main burners for scale, dust, or lint accumulation. Clean as needed.
- Check the vent system for soundness. Replace any parts that do not appear sound.
- Check the wiring for any damaged wire. Replace damaged wiring. (See the unit wiring diagram for replacement wiring requirements.)

10.2 Maintenance Procedures

10.2.1 Check Operating Gas Valve

WARNING: The operating valve is the prime safety shutoff. All gas supply lines must be free of dirt or scale before connecting to the unit to ensure positive closure. See Hazard Levels, page 2.

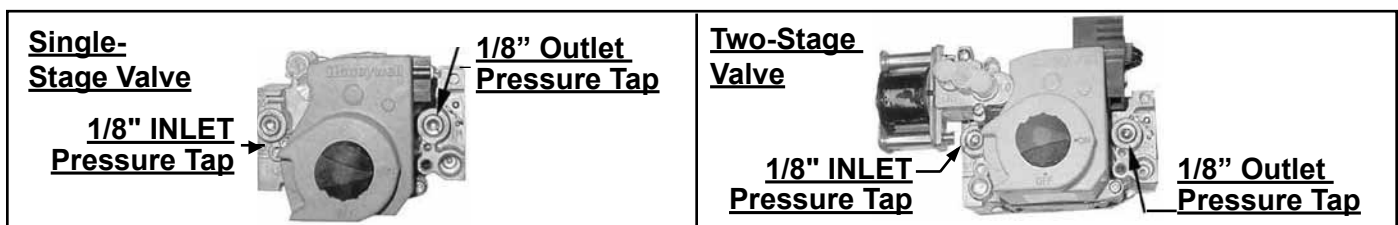
Carefully remove external dirt accumulation and check wiring connections.

The combination gas valve must be checked annually to ensure that the valve is shutting off gas flow completely.

Instructions:

FIGURE 35 - Gas Valve

- 1) Locate the 1/8" FPT **INLET** pressure tap on the combination valve (**FIGURE 35**).



NOTE: Operational pressure settings and instructions for checking pressure settings are in Paragraph 6.1.

- 2) With the manual valve turned off to prevent flow to the gas valve, connect a manometer to the 1/8" inlet pressure tap in the valve. **NOTE:** A manometer (fluid-filled gauge) with an inches water column scale is recommended.
- 3) With the field-installed manual valve remaining closed, observe the manometer for two to three minutes for an indication of gas pressure. No pressure should be indicated on the manometer.
If the manometer indicates a gas pressure, the field-installed manual gas valve must be replaced or repaired before the combination gas valve can be checked.
- 4) **If the manometer does not indicate gas pressure**, slowly open the field-installed manual gas valve. After the manometer's indicated gas pressure has reached equilibrium, close the manual shutoff valve. Observe the gas pressure. There should be no loss of gas pressure on the manometer. If the manometer indicates a loss of pressure, replace the combination gas valve before placing the heater in operation.

10. MAINTENANCE AND SERVICE (cont'd)

10.2.2 Burner Rack Removal

CAUTION: Eye protection is recommended.

These unit heaters have a convenient bottom access panel. The pilot is attainable with the bottom panel open. With the access panel removed, the burner rack assembly will hinge down for removal. Use the following step-by-step instructions for removal of the bottom access panel and the complete burner rack assembly.

Instructions for Burner Rack Removal (See FIGURES 36-41.)

1. Shut the gas supply off ahead of the combination valve.
2. Turn off electric supply.
3. Remove the two sheetmetal screws located at the rear of the bottom panel.
4. Allow bottom panel to hinge down from the front.
5. Push in one of the two spring-loaded hinge pins located at the front of the bottom panel (inside), and completely remove the bottom panel.
6. The bottom of the pilot is now visible. Do the following:
 - (a) Disconnect the pilot tubing from the pilot burner.
 - (b) For match-lit pilot (mfgd prior to 8/2008), disconnect the thermocouple from the valve.
 - (c) For spark pilot, disconnect the flame sensing wire and high tension (spark) lead from the ignition controller.

FIGURE 36
- Bottom
Access
Panel Open

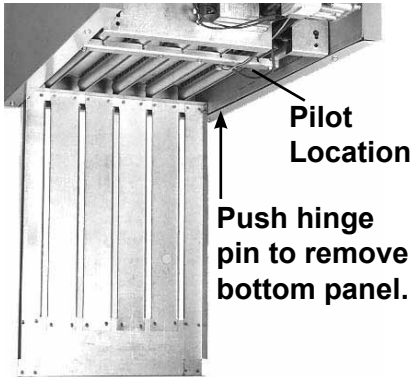
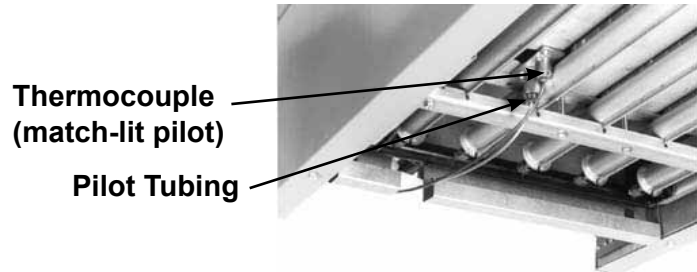


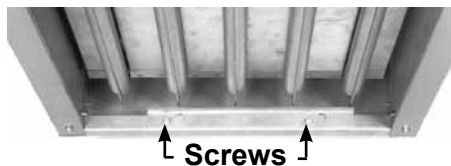
FIGURE 37 - Pilot Location



7A. Heaters manufactured beginning 8/91 (Serial No. Date Code AQH) - The burner rack support is indexed as illustrated in **FIGURE 38**. While supporting the burner rack, remove the screws (two or three) that hold the burner rack support. (For screw location, refer to **FIGURE 38**.) Remove the burner rack support allowing the burner rack assembly to swing down (See **FIGURE 39**).

7B. Heaters manufactured prior to 8/91 (Serial No. Date Code AQH) **Loosen** the sheetmetal screws (two or three) located at the front of the burner rack assembly. See **FIGURE 38**. These screws retain the burner rack support. While supporting the burner rack assembly, slide the burner rack support and remove it from the screws, allowing the burner rack assembly to swing down (See **FIGURE 39**).

**FIGURE 38 - Burner
Rack Support and
Retaining Screws**



Burner Rack Support with Indexing

NOTE: Burner Rack Support on units manufactured prior to 8/1991 was not indexed.

8. To Remove the Burner Rack - With the burner rack assembly "hanging" down, lift up on the rear and slide the assembly up and out of the manifold support brackets. See **FIGURES 39-41**.

9. To remove the individual burners (FIGURE 42):

- a. Remove the flash carryover (one screw per burner).
- b. With the burner rack upside down, remove the sheetmetal screws (located at the rear) that retain the burner hold down.
- c. Lift the rear of the burner upward slightly and pull back, removing the individual burners.



FIGURE 39 - Burner Rack Hinged Down

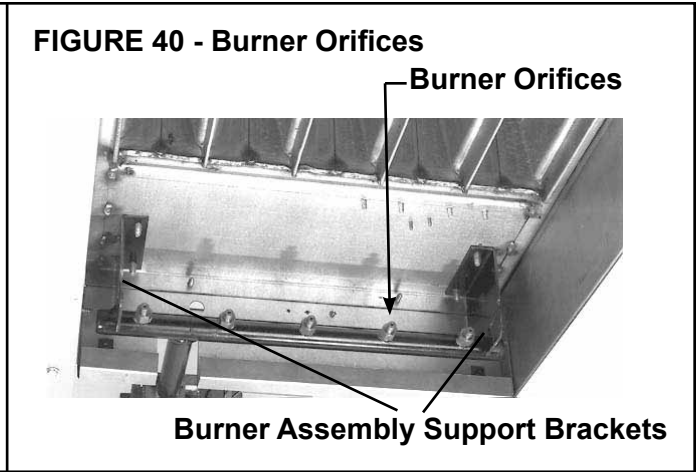


FIGURE 40 - Burner Orifices

Burner Orifices

Burner Assembly Support Brackets

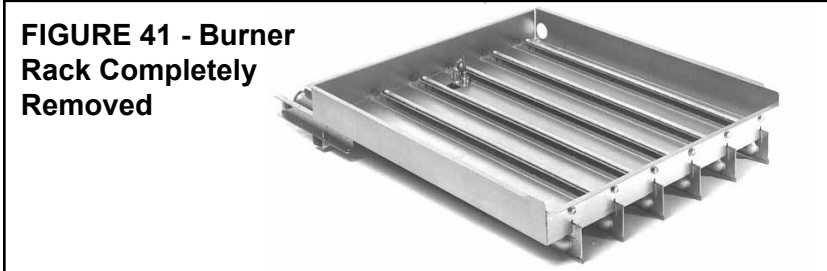


FIGURE 41 - Burner Rack Completely Removed

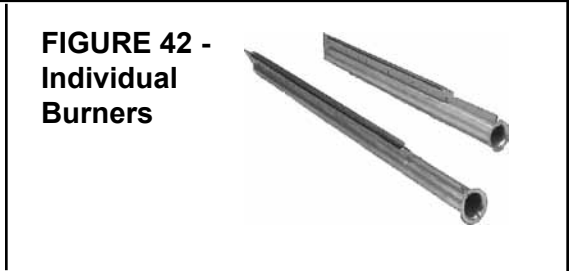


FIGURE 42 - Individual Burners

Individual burners may be cleaned using air pressure. Use an air nozzle to blow out scale and dust accumulation from the burner ports. Alternately, blow through burner ports and venturi.

Use a fine wire to dislodge any stubborn particles. Do not use anything that might change the port size.

d. To replace individual burners, reverse the above procedure.

10. To replace the burner rack assembly and the bottom panel, reverse the above procedure (Steps 1-8).

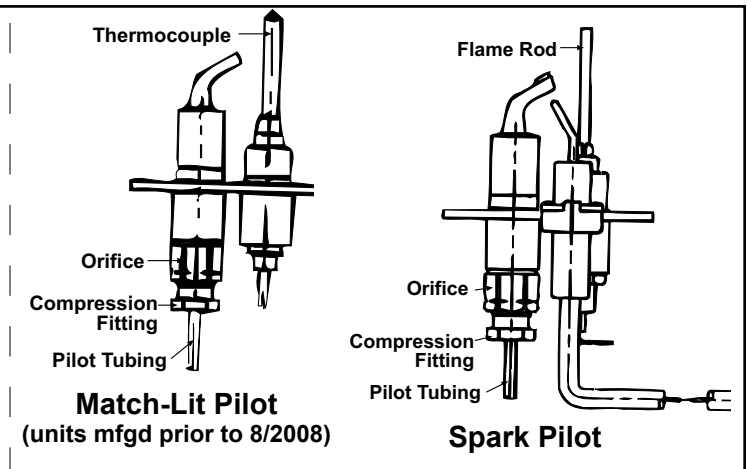
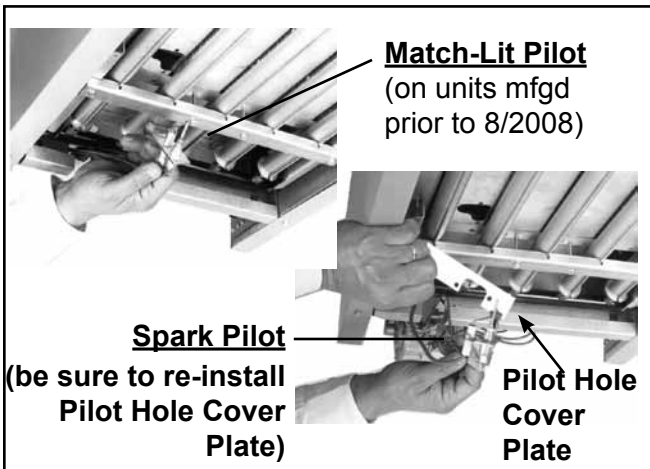
When any service is completed, be careful to reassemble correctly to ensure that no unsafe conditions are created. When re-lighting, always follow the lighting instructions on the heater.

10.2.3 Pilot and Ignition Systems

FIGURE 43 - Pilot Removal

The pilot can be serviced by opening the bottom access panel of the heater. Follow the first four steps of instructions for Burner Rack Removal, Paragraph 10.2.2. Remove the pilot for maintenance or service, such as checking the wiring and cleaning the orifice.

In the event the pilot flame is short and/or yellow, check the pilot orifice for blockage caused by lint or dust accumulation. Remove the pilot orifice and clean with air pressure. Check and clean the aeration slot in the pilot burner.



On a heater is equipped with a spark pilot, check the spark gap. Spark gap must be maintained to .100". (See **FIGURE 44.**) When re-installing the pilot of a heater with optional spark ignition, be sure to include the pilot hole cover plate (See **FIGURE 43**).

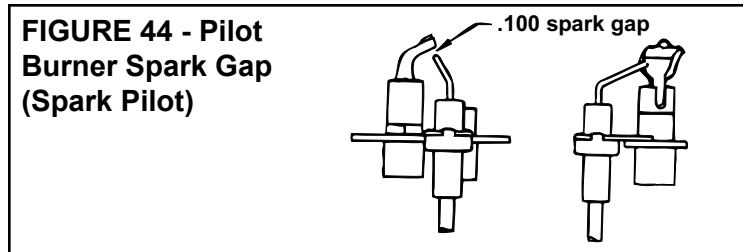
10. Maintenance and Service (cont'd)

10.2 Maintenance Procedures (cont'd)

10.2.3 Pilot and Ignition Systems (cont'd)

CAUTION: Due to high voltage on pilot spark wire and pilot electrode, do not touch when energized. See Hazard Levels, page 2.

FIGURE 44 - Pilot Burner Spark Gap (Spark Pilot)

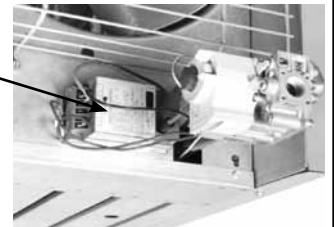


The **ignition controller** of the optional intermittent electronic ignition pilot system is visibly located on the back of the heater. (See **FIGURE 45.**) Do not attempt to disassemble the ignition controller. There are no field replaceable components in the control enclosure. However, each heating season the lead wires should be checked for insulation deterioration and good connections.

FIGURE 45 - Ignition Controller, UTEC 1003-514, P/N 257010, for Option AH3 Gas Control



Location of Ignition Controller



Proper operation of the electronic spark ignition system requires a minimum flame signal of .2 microamps as measured by a microammeter.

Service NOTE: If replacing an earlier style of ignition controller, order replacement kit **P/N 257472** for a unit with recycling gas control Option AH2 or **P/N 257473** for Option AH3 gas control with lockout. (Option codes are listed on the unit wiring diagram.) Use of a vent damper requires an ignition controller with lockout.

10.2.4 Burner Orifices

Heaters are shipped with orifices of proper size and type for gas and altitude specified on the order. When ordering replacement orifices, give BTUH content, specific gravity of gas, and altitude, as well as model and serial number of the heater.

10.2.5 Flash Carryover

FIGURE 46 - Burner Rack Flash Carryover

See **FIGURE 46.** The burner carryover system receives its gas supply from the main burner ports. Check the carryover assembly and also the main burner ports for cleanliness. Clean with air pressure.



CAUTION: Wearing eye protection when cleaning this heater is recommended.

10.2.6 Heat Exchanger

The outside of the heat exchanger can be cleaned from the front of the heater with an air hose and/or a brush. Remove all accumulated dust and grease deposits.

The inner surfaces of the heat exchanger can be reached for cleaning with the burner rack removed. (See Paragraph 10.2.2.) Cleaning can be done with a long furnace brush or a heavy wire to which steel wool has been attached. Brush up and down inside each heat exchanger tube until all foreign material is removed. A flashlight is helpful in examining the upper section of the tube.

10.2.7 Fan or Blower

Remove dirt and grease from the motor.

On fan model units, remove dirt and grease from the fan guard and blades. Use care when cleaning the fan blades to prevent causing misalignment or imbalance. Check that the hub of the fan blades is secure to the shaft.

On blower models, remove the grease and dirt from the blower housing and check the belt for wear and proper tension (See Paragraph 6.5).

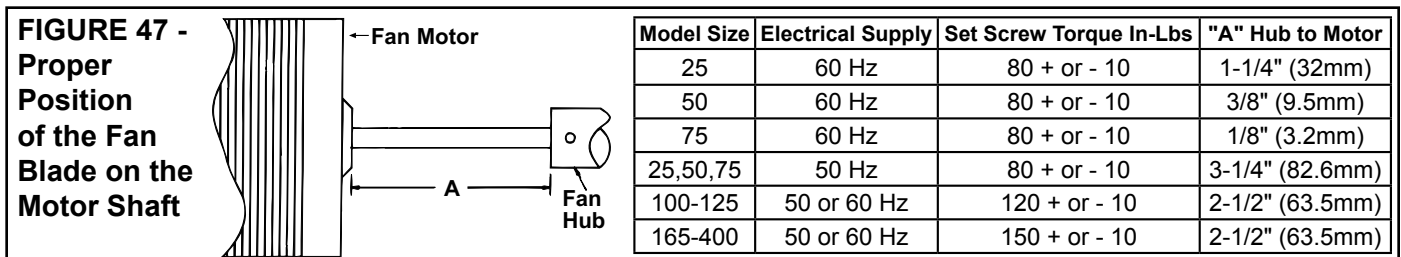
Lubricate if the motor has oil cups or grease fittings. The motor supplied as standard has lifetime lubrication and sleeve bearings.

On blower models, check current draw to motor rating plate.

Fan Models: Follow these instructions for replacement of the fan guard, fan motor or fan blades.

1. If the heater is installed, turn off the gas and disconnect the electric power.
2. Remove the left outer side panel (left when facing the rear of the unit). Disconnect the fan motor wires.
3. Depending on the date that the heater was manufactured, it will have either a lower-half fan guard only, two-piece full fan guard, or a one-piece full fan guard. If the unit has a two piece fan guard, remove the tension mounted upper half fan guard and the four screws that hold the lower half. If the unit has a one-piece fan guard, remove all of the screws that retain the fan guard. Remove the assembled parts (the fan guard, the motor, and the fan blade).
4. Disassemble and replace whatever parts are needed and reassemble using whatever part(s) are being replaced and the original parts. If the fan guard is being replaced, it is **important** that the same hardware be used for attaching the motor to the fan guard as was used with the original guard. These screws are especially made to cut through the coating on the fan guard to provide adequate grounding for the motor.

Be sure the fan blade is in proper position on the shaft. Position the fan as shown in **FIGURE 47** according to the chart.



Position the assembly on the heater. Attach the fan guard at the center mounts. (**IMPORTANT:** If replacing the fan guard, use the screws that held the original fan guard. These specially designed screws will cut through the coating on the fan guard to provide a ground for the fan motor.)

Rotate the fan blade to check for adequate clearance. If adjustment is required, loosen the mounting screws, re-position the fan guard, and tighten the screws. Rotate the fan blade and re-check for adequate clearance. Repeat this procedure until the assembly is positioned properly.

5. If necessary, drill the required upper and lower fan guard mounting holes. Attach the fan guard at all upper and lower mounting points using either the screws removed or field-installed sheetmetal screws.
6. Reconnect the fan motor wires and replace the outer side panel.
7. Restore power to the heater and turn on the gas. Light, following the instructions on the lighting instruction plate. Check for proper operation.

10.2.8 Vent System

Check the vent system at least once a year. Inspection should include all joints, seams, and the vent cap. Replace any defective parts.

10.2.9 Blocked Vent Switch

The manual reset blocked vent switch is located on the front top of the draft hood. The sensor is located near the relief opening of the draft hood.

| Blocked Vent Switch | | | | |
|---------------------|---------------------------|--------|------------------------|--------|
| Model Size | Single-Stage Gas Controls | | Two-Stage Gas Controls | |
| | Temperature Setting | P/N | Temperature Setting | P/N |
| 25 | 200°F | 112751 | N/A | N/A |
| 50 | 225°F | 112752 | N/A | N/A |
| 100-400 | 275°F | 121275 | 225°F | 112752 |

10.2.10 Fan, Limit, & ECO Controls

NOTE: ECO control is not on any units manufactured after 8/2008. All units with match-lit pilot have an ECO device. Units with spark pilot manufactured prior to 8/99 have an ECO device.

If it is determined that the fan or limit controls or the ECO device needs replacing, use only factory-authorized replacement parts that are designed for your heater. See locations in **FIGURE 48**.

WARNING: An ECO circuit interruption is a major failure caused by a malfunction of the primary safety controls or mis-wiring, and will require correction of the cause of the failure and the replacement of the fan and limit controls and wiring before the heater can be returned to service. See Hazard Levels, page 2.

10. Maintenance and Service (cont'd)

10.2 Maintenance Procedures (cont'd)

10.2.10 Fan, Limit, & ECO Controls (cont'd)

Instructions for replacing fan or limit control and ECO device:

1. Turn off the electric power and shut off the gas supply.
2. Remove the outer left side panel left when facing the back of the unit). Remove the access panel.
3. Remove defective controls. Install new controls in the same mounting holes. Use only factory-authorized replacement parts.
4. Replace access panel and side panel.
5. Turn on the electric power and the gas supply.
6. Relight following the lighting instructions on the heater.

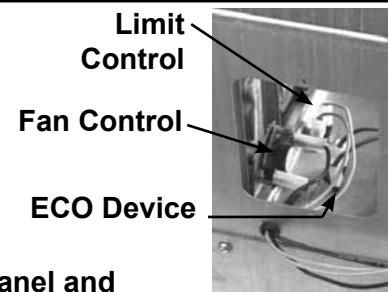


FIGURE 48 - Side Panel and Access Panel Removed showing Fan Control, Limit Control, and ECO (See NOTE on page 37.)

10.3 Troubleshooting

| TROUBLE | PROBABLE CAUSE | REMEDY |
|---|--|--|
| Pilot will not light (match-lit pilot system) | <ol style="list-style-type: none"> 1. Pilot valve turned off. 2. Air in gas line. 3. Incorrect lighting procedure. 4. Dirt in pilot orifice. 5. Gas pressure too high or too low. 6. Bent or kinked pilot tubing. 7. Failed ECO device. | <ol style="list-style-type: none"> 1. Open manual valve. 2. Disconnect pilot line at shutoff. Bleed air from gas supply line. 3. Follow instructions o the heater. 4. Remove and clean with compressed air or solvent (do not ream). 5. Check gas supply pressure. (See Paragraph 6.1). 6. Replace tubing. 7. Replace ECO device (See Paragraph 10.2.9). |
| Pilot will not light (spark ignition) | <ol style="list-style-type: none"> 1. Manual valve not open. 2. Power not turned on or thermostat not calling for heat. 3. Air in gas line. 4. Dirt in pilot orifice. 5. Gas pressure too high or too low. 6. Bent or kinked pilot tubing. 7. Pilot valve does not open. 8. No spark: <ol style="list-style-type: none"> a) Loose wire connections b) Transformer failure. c) Incorrect spark gap. d) Spark cable shorted to ground. e) Spark electrode shorted to ground. f) Drafts affecting pilot. g) Ignition control not grounded. h) Faulty ignition controller. 9. Optional lockout device interrupting control circuit by above causes. 10. Faulty blocked vent switch. | <ol style="list-style-type: none"> 1. Open manual valve. 2. Turn on power. Check fuse/circuit breaker in disconnect switch. If unit is equipped with unit-mounted disconnect switch, check circuit breaker. (See Paragraph 7.) Check thermostat setting. 3. Bleed gas line. 4. Remove and clean with compressed air or solvent (do not ream). 5. Adjust supply pressure. (See Paragraph 6.1). 6. Replace tubing. 7. If 24 volt available at valve, replace valve. 8. <ol style="list-style-type: none"> a) Be certain all wires connections are solid. b) Be certain 24 volts is available. c) Maintain spark gap at .100". d) Replace worn or grounded spark cable. e) Replace pilot if ceramic spark electrode is cracked or grounded. f) Make sure all panels are in place and tightly secured to prevent drafts at pilot. g) Make certain ignition control is grounded to furnace chassis h) If 24 volt is available to ignition controller and all other causes have been eliminated, replace ignition control. 9. Reset lockout by interrupting control at thermostat. 10. Correct venting problem; reset switch (see Paragraph 8.2). |
| Pilot lights, main valve will not open (all manual valves are open, match-lit pilot) | <ol style="list-style-type: none"> 1. Power not turned on or thermostat not calling for heat. 2. Circuit to magnetic valve open. 3. Faulty transformer 4. Faulty or dirty thermocouple or safety pilot switch or failed ECO device. 5. Faulty thermostat (see manufacturer's instructions) 6. Faulty magnetic valve 7. High gas pressure 8. Activated blocked vent switch | <ol style="list-style-type: none"> 1. Turn on power. Check fuse/circuit breaker in disconnect switch. If unit is equipped with unit-mounted disconnect switch, check circuit breaker. (See Paragraph 7.2.) Check thermostat setting. 2. Check wiring and connections at transformer and thermostat. 3. Replace transformer. 4. Clean and test with millivolt meter or test kit. Replace defective part. 5. Replace thermostat 6. Replace valve or magnetic heat, 7. Maximum gas supply pressure is 14"w.c. (See Paragraph 6.1.) 8. Correct venting problem; reset switch (see Paragraph 8.2). |
| Pilot lights, main valve will not open (Spark Ignition system) | <ol style="list-style-type: none"> 1. Manual valve not open. 2. Main valve not operating. <ol style="list-style-type: none"> a) Defective valve. b) Loose wire connections. 3. Ignition control does not power main valve. <ol style="list-style-type: none"> a) Loose wire connections. b) Flame sensor grounded (pilot lights - spark continues) c) Gas pressure incorrect. d) Cracked ceramic at sensor. e) Faulty ignition controller. | <ol style="list-style-type: none"> 1. Open manual valve. 2. <ol style="list-style-type: none"> a) If 24 volt is measured at valve connections and valve remains closed, replace valve. 3. <ol style="list-style-type: none"> b) Check and tighten all wiring connections. c) Check and tighten all wiring connections d) Be certain flame sensor lead is not grounded or insulation of ceramic is not cracked. Replace sensor as required. e) Supply pressure should be 5 - 14" w.c. for natural gas and 11- 14" w.c. for propane gas. f) Replace sensor. g) See Paragraph 10.2.3. If all checks indicate no other cause, replace ignition controller. DO NOT ATTEMPT TO REPAIR IGNITION CONTROLLER. THIS DEVICE HAS NO FIELD REPLACEABLE PARTS. |

| TROUBLE | PROBABLE CAUSE | REMEDY |
|--|--|---|
| No heat (Heater Operating) | 1. Incorrect manifold pressure or orifices. 2. Cycling on limit control. 3. Improper thermostat location or adjustment. | 1. Check manifold pressure (See Paragraph 6.1). 2. Check air throughput (See Paragraph 16). 3. See thermostat manufacturer's instructions. |
| Cold air delivered On Start-up During Operation | 1. Fan control improperly wired 2. Defective fan control. 3. Incorrect manifold pressure. | 1. Connect as per wiring diagram. 2. Replace fan control. 3. Check manifold line pressure (See Paragraph 6.1). |
| Motor will not run | 1. Circuit open. 2. Fan control inoperative. 3. Defective motor or capacitor. | 1. Check wiring and connections. . 2. Replace fan control. 3. Replace motor or capacitor. |
| Motor turns on and off while burner is operating (See motor cuts out on overload below) | 1. Fan control improperly wired. 2. Defective fan control. 3. Poor contact between fan control and heat exchanger tube. Surface contact is required. 4. Motor overload device cycling on and off 5. Low ambient temperature (less than 40°F) causing false cycling | 1. Connect as per wiring diagram. 2. Replace fan control. 3. Check for bent mounting or loose mounting screws. 4. Check motor load against motor rating plate. Replace motor if needed. 5. Install fan delay kit (See Paragraph 8.1). |
| Fan motor cuts out on overload | 1. Low or high voltage supply . 2. Defective motor. 3. Poor air flow. 4. Defective bearing or lubrication. | 1. Correct electric supply. 2. Replace motor. 3. Clean motor, fan and fan guard. 4. Lubricate bearings or replace motor. |
| Blower motor cuts out on overload | 1. Improper motor pulley and/or adjustment. 2. Improper static pressure in the duct system. 3. Low voltage. | 1. See instructions in Paragraph 6.5. 2. Adjust duct system dampers. 3. Check power supply. |

INDEX

A

Air Shutter Adjustment 31

B

Belt Tension 22
Blocked Vent Switch 30, 37
Blower 36
Blower/Filter Cabinet 19
Blower Operation 22
Blower Rotation 23
Blower Speed Adjustment 22
Burner Air Adjustment 31
Burner Orifices 35, 36
Burner Rack Removal 34
Burner Rack Support 34

C

Carryover 36
Clearances 8
Combustion Air Requirements 4
Confined Space 4
Electrical Supply Connections 24
Contact 40
Control Wiring 24

D

Vent Control Damper 19
Derating by Valve Outlet 15
Dimensions 9
Direct Drive 22
Unit Discharge 20
Downturn Air Nozzles 20
Duct Flange 20

E

ECO Control 37, 38
Electrical Supply and Wiring 23

F

Fan 22, 36
Fan Blade 37

Fan Control 30, 38
OPTIONAL 50 HERTZ OPERATION 24
Flash Carryover 36
Field assembly of the flue outlet 5

G

Gas Supply and Connections 13
Guard Options - Model B 7

H

Hanger Kits 12
Hanging the Heater 11
Hazard Labels 2
Heat Exchanger 36
High Altitude Installation 5

I

Ignition System 31, 35, 36
Inlet Air - Blower Model B 19
Installation Codes 3

L

Lifting 11
Limit 37, 38
Heater Location 3
Optional Vertical Louvers 20

M

MAINTENANCE 33
Maintenance Schedule 33
Multiple Heater Control 25

N

Downturn Nozzles 20

O

Orifice Pressure Settings 15

P

Pilot 31, 35, 36
Piping Connection 14
Polytube Adapter 21
Power Venting 19

Preparing the Heater for Installation 4
Outlet (Manifold) Pressure by Elevation 15

S

SAFETY 1
Spark Gap 36
Start-Up 32
Suspending 11

T

Troubleshooting 38

U

Uncrating and Inspecting 4

V

Check Valve Outlet (Manifold) Pressure 15
Gas Valve 30, 33
Vent Control Damper 19
Venting 16
Venting Arrangement 18
Venting Requirements 16
Vent Outlet 5
Vent Outlet Instructions for Size 125 6
Vent Outlet Instructions for Sizes 25, 50, 75, 100, 165 and 200 6
Vent Outlet Instructions for Sizes 250, 300 and 400 7
Vent Outlet Positions 6
Vent Outlet Sizes 16
Vent System 37
Vent with Condensate Drain 17
Vertical Louvers 20
Supply Voltage 23, 24

W

Warranty 3
Weights 11
Wiring Diagrams 26

INSTALLATION RECORD - to be completed by the installer:

Installer:

Name _____
Company _____
Address _____

Phone _____

Distributor (company from which the unit was purchased):

Company _____
Contact _____
Address _____

Phone _____

Model _____ Serial No. _____ Date of Installation _____

SPECIFIC INSTALLATION NOTES: (i.e. Location, Amps, Gas Pressure, Temperature, Voltage, Adjustments, Warranty, etc.)

BUILDING OWNER OR MAINTENANCE PERSONNEL:

For service or repair

- Contact the installer listed above.
- If you need additional assistance, contact the Reznor Distributor listed above.
- For more information, contact your Reznor Representative by calling 800-695-1901.

Reznor, LLC
150 McKinley Avenue
Mercer, PA 16137

www.ReznorHVAC.com
(800) 695-1901

©2014 Reznor, LLC. All rights reserved.

Trademark Notes: Reznor® is registered in at least the United States.

All other trademarks are the property of their respective owners.

0514 Form I-F/B (Version C.4)

REZNOR®

Form I-F/B, P/N 98126 R21, Page 40