



The Green Solution

2" SureSeal® PLUS MODEL #SS2009P

WATERLESS INLINE DRAIN TRAP SEAL with BUILT-IN CHECK VALVE



Specification: SureSeal Plus model SS2009P Waterless Inline Trap Seal with integral pressure relief valve. Commercial grade HDPE plastic housing with proprietary heavy duty silicone diaphragm and EPDM soft rubber sealing gasket. Floor Rating ASSE 1072 AF GW.

Function: Installs into the outlet of drain bodies, drain hubs, or floor sinks to protect the trap seal from evaporation. Creates a physical barrier that blocks bugs, sewer gases and odors from escaping; PLUS, it holds back up to 5' of columnar (head) back flow pressure. Built-in pressure relief valve equalizes air pressure if needed. Provides waterless trap seal protection equivalent to water based trap primers.

- **New Construction:** Used as a trap primer replacement or in conjunction with a trap primer to provide protection against escaping sewer gases and protection from water/sewer backups. Eliminates the need to repair/replace trap primers when they fail, and/or prevents damage caused by backups.
- **Retrofit:** Used in situations where trap primers have failed or where trap primers were never installed and/or where protection from back flow is needed.

Benefits: Simple to install, eliminates the need for complex, time consuming, and expensive repairs to fix a failed trap primer or damage caused by water/sewer backup. No Guessing - SureSeal Plus has a built-in torque release and is installed with a 3/8" ratchet and extension. **NO TRAP PRIMER NEEDED! ECO FRIENDLY PROVIDES 100% WATER SAVINGS EFFICIENCY OVER TRADITIONAL METHODS.**

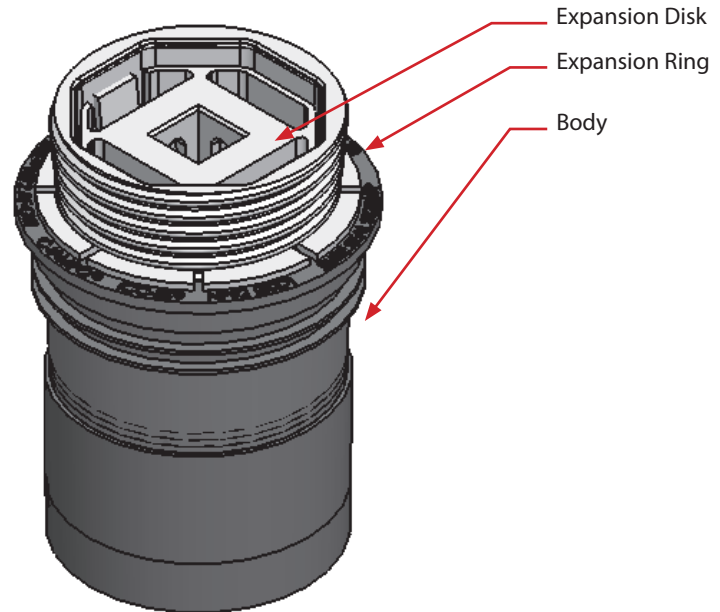
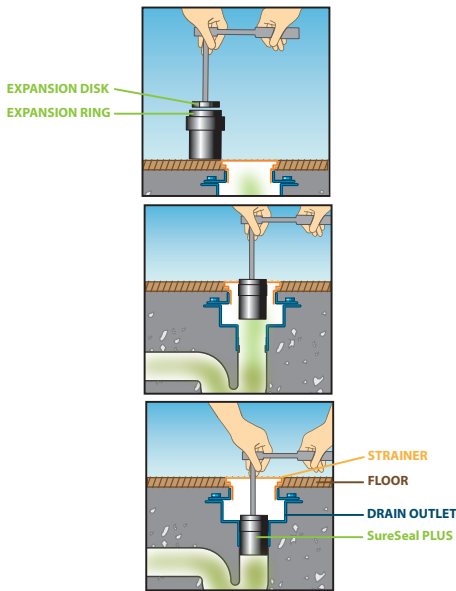

ICC-ES Listed: PMG-1070

IAPMO Listed: C-4165

U.S. Patent 9,010,363

Other Patents Pending

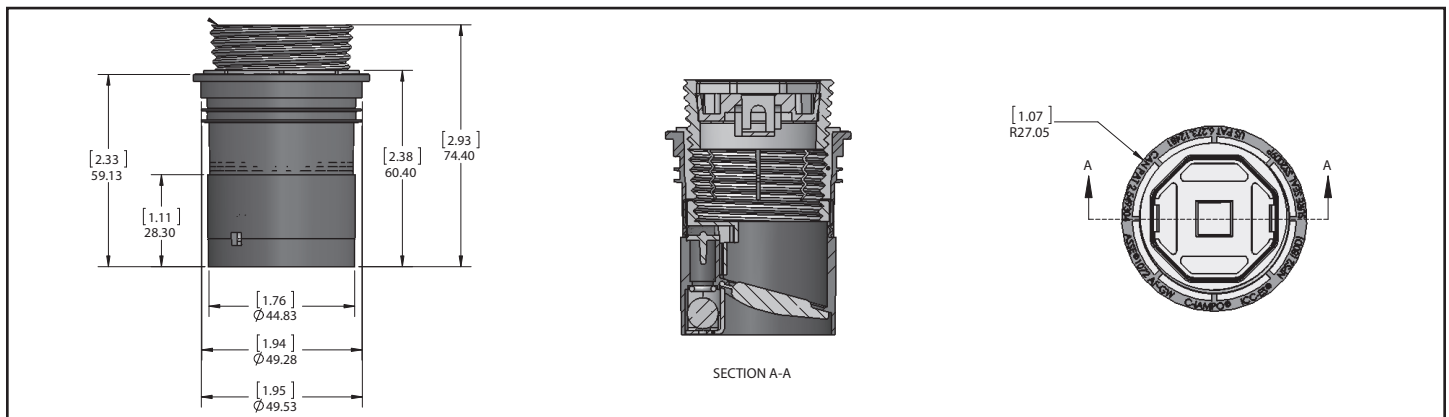



The Green Solution



3" SureSeal® PLUS MODEL #SS3009P

INLINE FLOOR DRAIN TRAP SEALER

Specification: SureSeal Plus model SS3009P Waterless Inline Trap Seal with integral pressure relief valve. Commercial grade HDPE plastic housing with proprietary heavy duty silicone diaphragm and EPDM soft rubber sealing gasket. Floor Rating ASSE 1072 AF GW.

Function: Installs into the outlet of drain bodies, drain hubs, or floor sinks to protect the trap seal from evaporation. Creates a physical barrier that blocks bugs, sewer gases and odors from escaping; PLUS, it holds back up to 5' of column water back flow. Built-in pressure relief valve equalizes air pressure if needed. Provides waterless trap seal protection equivalent to water based trap primers.

- **New Construction:** Used as a trap primer replacement or in conjunction with a trap primer to provide protection against escaping sewer gases and protection from water/sewer backups. Eliminates the need to repair/replace trap primers when they fail, and/or fix damage caused if the drain backs up.
- **Retrofit:** Used in situations where trap primers have failed or where trap primers were never installed and/or where protection from back flow drains is needed.

Benefits: Simple to install, eliminates the need for complex, time consuming, and expensive repairs to fix a failed trap primer or damage caused by water/sewer backup. No Guessing - SureSeal Plus has a built-in torque release and is installed with a 3/8" ratchet and extension. **NO TRAP PRIMER NEEDED! ECO FRIENDLY PROVIDES 100% WATER SAVINGS EFFICIENCY OVER TRADITIONAL METHODS.**

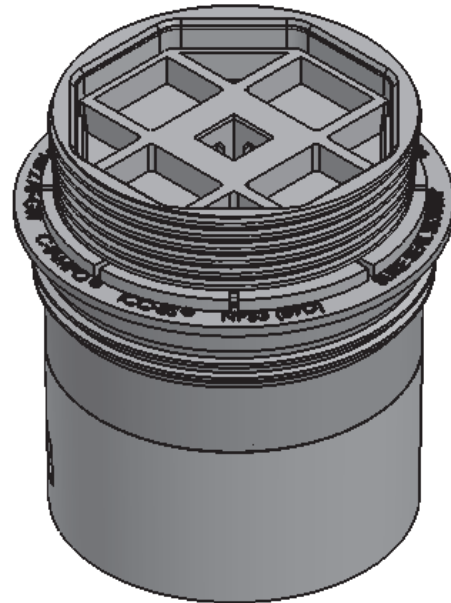
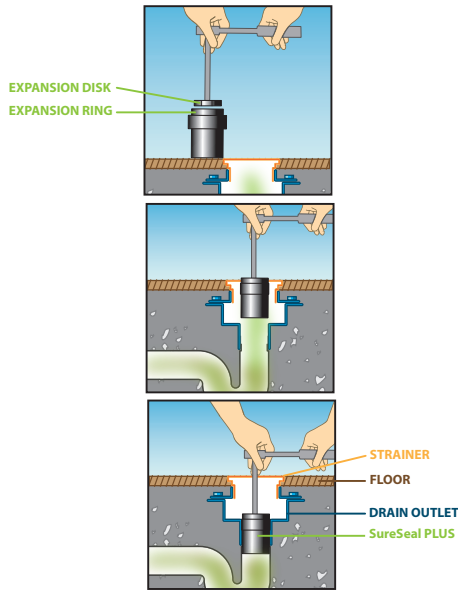

ICC-ES Listed: PMG-1070

IAPMO Listed: C-4165

U.S. Patent 9,010,363

Other Patents Pending

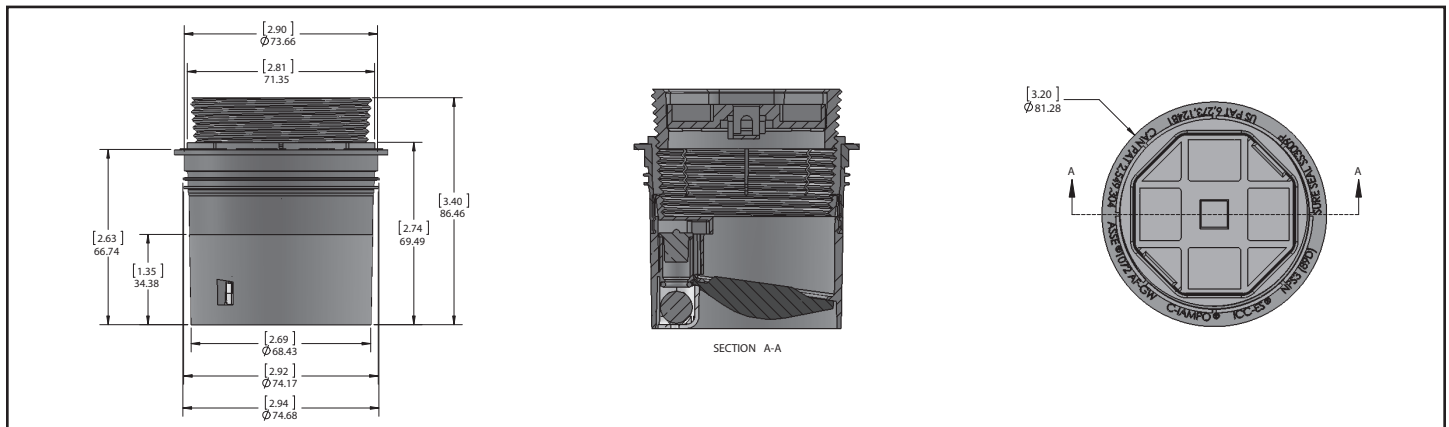

Contact: RectorSeal® 2601 Spenwick Drive, Houston, TX

P 713-263-8001

| 800-231-3345

F 713-263-7577

| 800-441-0051

W rectorseal.com