

AM9S 80% FER Up Flow Furnace

AM9S800403AXAA
AM9S800603AXAA
AM9S800603BNAA
AM9S800604BXAA
AM9S800803BXAA
AM9S800804BXAA
AM9S800804CXAA
AM9S800805CXAA
AM9S801005CXAA
AM9S801205DXAA

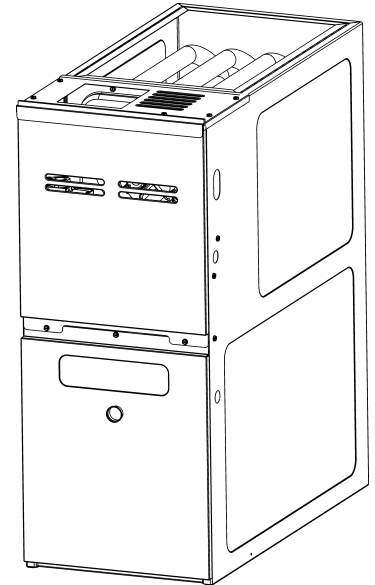

Amana® is a registered trademark of Maytag Corporation or its related companies and is used under license. All rights reserved.

This manual is to be used by qualified technicians only.

Important Information

Index

Functional Parts List	3
Illustration and Parts	4 - 9

Views shown are for parts illustrations only, not servicing procedures.

Text Codes:

AR - As Required

NA - Not Available

NS - Not Shown

00000000 - See Note

QTY - Quantity Example (QTY 3) (If Quantity not shown, Quantity = 1)

M - Model Example (M1) (If M Code not shown, then part is used on all Models)

Expanded Model Nomenclature:

Example
M1 - Model#1
M2 - Model#2
M3 - Model#3

Goodman Company, L.P. is not responsible for personal injury or property damage resulting from improper service. Review all service information before beginning repairs.

Warranty service must be performed by an authorized technician, using authorized factory parts. If service is required after the warranty expires, Goodman Company, L.P. also recommends contacting an authorized technician and using authorized factory parts.

Goodman Company, L.P. reserves the right to discontinue, or change at any time, specifications or designs without notice or without incurring obligations.

For assistance within the U.S.A. contact:

Homeowner Support
Goodman Company, L.P.
19001 Kermier Road
Waller, Texas 77484
877-254-4729-Telephone
713-863-2382-Facsimile

For assistance outside the U.S.A. contact:

International Division
Goodman Company, L.P.
19001 Kermier Road
Waller, Texas 77484
713-861-2500-Telephone
713-863-2382-Facsimile

Functional Parts

Part

No: Description:

PCBBF163	CIRCUIT BOARD FURNACE
0130F00010	FLAME SENSOR
0151M00037	GAS VALVE
10690402	INTERLOCK SWITCH
20162903	LIMIT, PRIMARY (M7, M8, M10)
20162901	LIMIT, PRIMARY (M1)
20162904	LIMIT, PRIMARY (M2, M3, M4, M5, M6, M9)
0130F00038	LIMIT, PRIMARY 120 LT BLUE
10123529	LIMIT-RESET MAN-GREEN (QTY 2)
0131F00251	MOTOR PROGRAMMED (M6)
0131F00246	MOTOR PROGRAMMED (M1)
0131F00247	MOTOR PROGRAMMED (M2)
0131F00248	MOTOR PROGRAMMED (M3)
0131F00250	MOTOR PROGRAMMED (M5)
0131F00252	MOTOR PROGRAMMED (M7)
0131F00253	MOTOR PROGRAMMED (M8)
0131F00254	MOTOR PROGRAMMED (M9)
0131F00255	MOTOR PROGRAMMED (M10)
0131F00249	MOTOR PROGRAMMED (M4)
0131M00002P	MOTOR, VENT 80+
0130F00008	SINI IGNITOR
0130F00505	SWITCH, PRESSURE (M1, M5, M6, M9)
0130F00507	SWITCH, PRESSURE (M10)
0130F00506	SWITCH, PRESSURE (M2, M3, M4, M7, M8)
0130M00140	TRANSFORMER,(120V TO 24V,40VA,

Expanded Model Nomenclature

M1 - AM9S800403AXAA
M2 - AM9S800603AXAA
M3 - AM9S800603BNAA
M4 - AM9S800604BXAA
M5 - AM9S800803BXAA
M6 - AM9S800804BXAA
M7 - AM9S800804CXAA
M8 - AM9S800805CXAA
M9 - AM9S801005CXAA
M10 - AM9S801205DXAA

0161F00006	AMANA NAMEPLATE
HI-130	HOMEOWNERS INSTRUCTIONS
IOG-2030	INSTALLATION INSTRUCTIONS
PWAFURNSUNT	PRODUCT WARRANTY

Cabinet and Control Panel Assembly

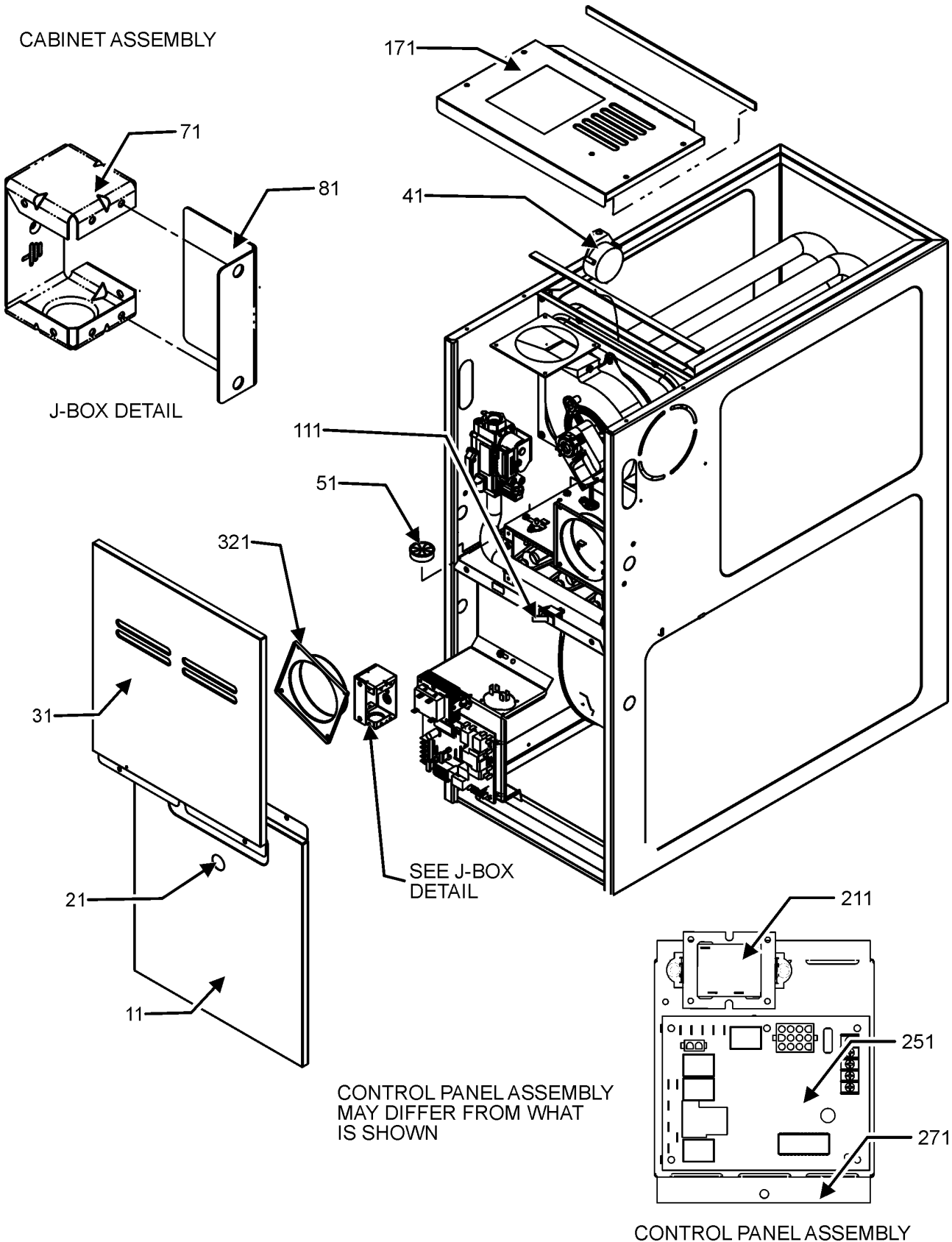

CABINET ASSEMBLY MAY DIFFER FROM WHAT IS SHOWN

Cabinet and Control Panel Assembly

Ref. Part No:	No:	Description:	Ref. Part No:	No:	Description:
Image 1:					
11	0121F00122LG	DOOR, BLOWER, 14"-PAINTED (M1, M2)			
11	0121F00123LG	DOOR, BLOWER, 17.5" PAINTED (M3, M4, M5, M6)			
11	0121F00124LG	DOOR, BLOWER, 21"-PAINTED (M7, M8, M9)			
11	0121F00125LG	DOOR, BLOWER, 24.5"-PAINTED (M10)			
21	B1392139	VIEW PORT BUSHING-BLOWER DOOR			
31	0121F00118LG	DOOR CTRL ACCESS, 14"-PAINTED (M1, M2)			
31	0121F00120LG	DOOR CTRL ACCESS, 21"-PAINTED (M7, M8, M9)			
31	0121F00121LG	DOOR CTRL ACCESS, 24.5"PAINTED (M10)			
31	0121F00119LG	DOOR CTRL ACCESS,17.5"-PAINTED (M3, M4, M5, M6)			
41	0130F00505	SWITCH, PRESSURE (M1, M5, M6, M9)			
41	0130F00506	SWITCH, PRESSURE (M2, M3, M4, M7, M8)			
41	0130F00507	SWITCH, PRESSURE (M10)			
51	B1392147	UNIVERSAL BUSHING WITH SLICE			
71	4014502	J-BOX			
81	4015502	COVER, J-BOX			
111	10690402	INTERLOCK SWITCH			
171	0121F00141DG	TOP, FURNACE 14"-PAINTED (M1, M2)			
171	0121F00142DG	TOP, FURNACE 17.5"-PAINTED (M3, M4, M5, M6)			
171	0121F00143DG	TOP, FURNACE 21"-PAINTED (M7, M8, M9)			
171	0121F00463DG	TOP, FURNACE 24.5" PAINTED (M10)			
211	0130M00140	TRANSFORMER, (120V TO 24V, 40VA,			
251	PCBBF163	CIRCUIT BOARD FURNACE			
271	0121F00744	PANEL, CONTROL MOUNTING			
321	4023500	CHIMNEY TRANSITION TOP			
NS	0161F00006	AMANA NAMEPLATE			
NS	HI-130	HOMEOWNERS INSTRUCTIONS			
NS	IOG-2030	INSTALLATION INSTRUCTIONS			
NS	PWAFURNSUNT	PRODUCT WARRANTY			

Expanded Model Nomenclature

M1 - AM9S800403AXAA
M2 - AM9S800603AXAA
M3 - AM9S800603BNAA
M4 - AM9S800604BXAA
M5 - AM9S800803BXAA
M6 - AM9S800804BXAA
M7 - AM9S800804CXAA
M8 - AM9S800805CXAA
M9 - AM9S801005CXAA
M10 - AM9S801205DXAA

Blower Assembly

BLOWER ASSEMBLY

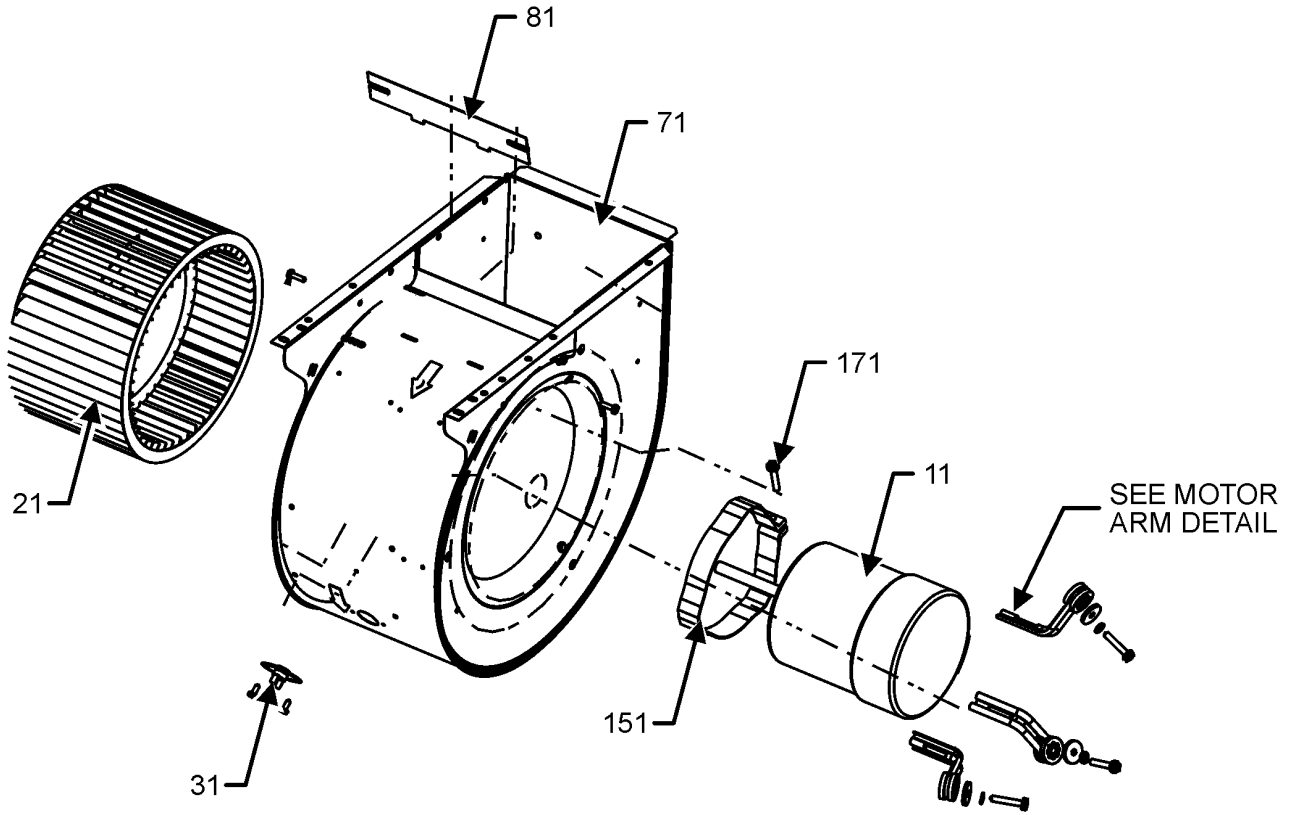

LIMIT LOCATION MAY DIFFER FROM WHAT IS SHOWN

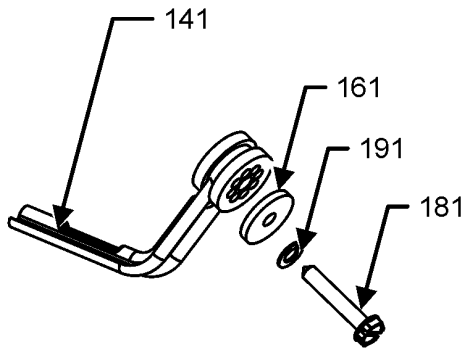

MOTOR ARM DETAIL

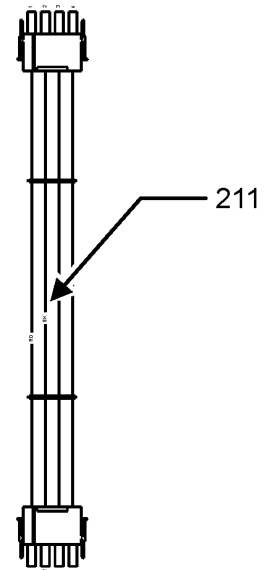

BLOWER ASSEMBLY MAY DIFFER FROM WHAT IS SHOWN

Blower Assembly

Ref. Part No:	Ref. Part No:	Description:	Description:
Image 1:			
11	0131F00246	MOTOR PROGRAMMED (M1)	
11	0131F00247	MOTOR PROGRAMMED (M2)	
11	0131F00248	MOTOR PROGRAMMED (M3)	
11	0131F00249	MOTOR PROGRAMMED (M4)	
11	0131F00250	MOTOR PROGRAMMED (M5)	
11	0131F00251	MOTOR PROGRAMMED (M6)	
11	0131F00252	MOTOR PROGRAMMED (M7)	
11	0131F00253	MOTOR PROGRAMMED (M8)	
11	0131F00254	MOTOR PROGRAMMED (M9)	
11	0131F00255	MOTOR PROGRAMMED (M10)	
21	0150M00042	WHEEL, BLOWER (10 X 10) (M7, M8, M9)	
21	0150M00043	WHEEL, BLOWER (10 X 8) (M3, M4, M5, M6)	
21	0150M00061	WHEEL,BLOWER (M1, M2)	
21	0150M00062	WHEEL,BLOWER (M10)	
31	0130F00038	LIMIT, PRIMARY 120 LT BLUE	
71	2539307	BLWR SHL ASM 10X10 10X10 (M7, M8, M9, M10)	
71	2539305	BLWR SHL ASM 10X6 10X6 (M1, M2)	
71	2539306	BLWR SHL ASM 10X8 10X8 (M3, M4, M5, M6)	
81	764741	BLWR BLK-OFF,10X10 (M7, M8, M9, M10)	
81	764739	BLWR BLK-OFF,10X6 (M1, M2)	
81	764740	BLWR BLK-OFF,10X8 (M3, M4, M5, M6)	
141	0163M00538	MOUNT ARM, MOTOR (QTY 3)	
151	0121M00039	MOTOR MOUNT BAND (HEAVY DUTY)	
161	B1392918	WASHER, FLAT 1/4 ID X 1 OD (QTY 3)	
171	0163M00320	HEX HEAD ALL THREAD TAP BOLT	
181	M0250565	SCREW-TC 1.25" (QTY 3)	
191	B1393800	LOCK NUT NYLON IINISERT 1/4 20	
211	0159F00119	CTM, MOTOR HARNESS	

Expanded Model Nomenclature

M1 - AM9S800403AXAA
M2 - AM9S800603AXAA
M3 - AM9S800603BNAA
M4 - AM9S800604BXAA
M5 - AM9S800803BXAA
M6 - AM9S800804BXAA
M7 - AM9S800804CXAA
M8 - AM9S800805CXAA
M9 - AM9S801005CXAA
M10 - AM9S801205DXAA

Heat Exchange Assembly

HEAT EXCHANGE ASSEMBLY

FLUE COLLECTOR BOX ASSEMBLY

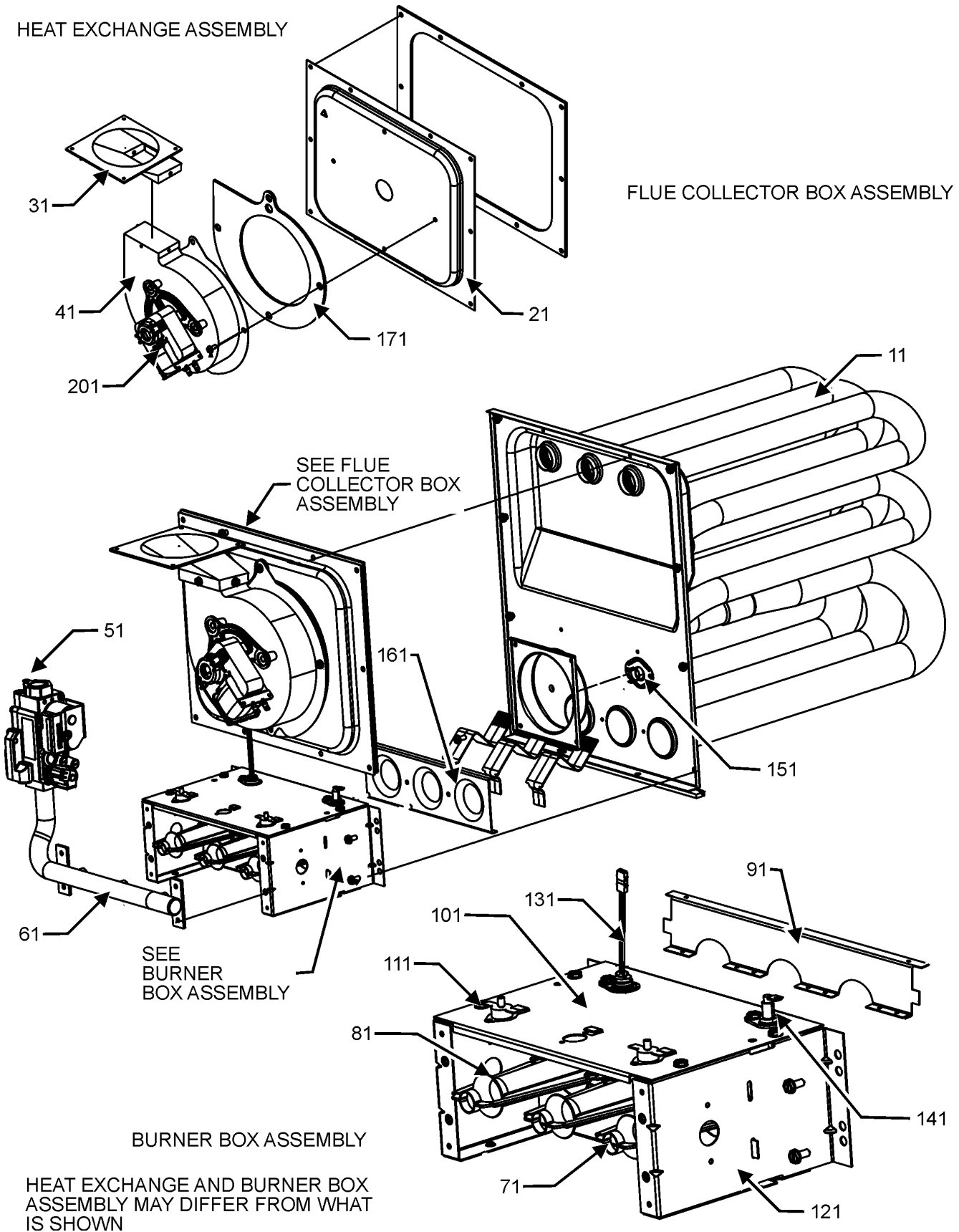

Heat Exchange Assembly

Ref. Part No:	Ref. Part No:	Description:	Description:
Image 1:		Expanded Model Nomenclature	
11	0270F00931	HEAT EXCHANGER ASSY (M1)	M1 - AM9S800403AXAA
11	0270F00932	HEAT EXCHANGER ASSY (M2)	M2 - AM9S800603AXAA
11	0270F00933	HEAT EXCHANGER ASSY (M3, M4)	M3 - AM9S800603BNAA
11	0270F00934	HEAT EXCHANGER ASSY (M5, M6)	M4 - AM9S800604BXAA
11	0270F00935	HEAT EXCHANGER ASSY (M7, M8)	M5 - AM9S800803BXAA
11	0270F00936	HEAT EXCHANGER ASSY (M9)	M6 - AM9S800804BXAA
11	0270F00937	HEAT EXCHANGER ASSY (M10)	M7 - AM9S800804CXAA
21	0121F00333	21" COLLECTOR BOX 1.75" DIA (M7, M8)	M8 - AM9S800805CXAA
21	0121F00330	24.5" COLLECTOR BOX 2.125" DIA (M10)	M9 - AM9S801005CXAA
21	0121F00217	COLLECTOR BOX (M9)	M10 - AM9S801205DXAA
21	0121F00126	COLLECTOR BOX 14" 1.375 DIA (M1)	
21	0121F00128	COLLECTOR BOX 17.5" 1.75 DIA (M3, M4, M5, M6)	
21	0121F00198	COLLECTOR BOX, 14" 1.75 DIA (M2)	
31	0128F00006	TRANSITION, BOTTOM	
41	0131M00002P	MOTOR, VENT 80+	
51	0151M00037	GAS VALVE	
61	0120F00006	MANIFOLD (M1)	
61	0120F00007	MANIFOLD (M2, M3, M4)	
61	0120F00008	MANIFOLD (M5, M6, M7, M8)	
61	0120F00009	MANIFOLD (M9)	
61	0120F00010	MANIFOLD (M10)	
71	10716005	ORIFICE (QTY 2)	
81	B4022700	INSHOT BURNER ASSY 3" (QTY 2)	
91	0121F00167	BURNER RACK, 2 CELL (M1)	
91	0121F00168	BURNER RACK, 3 CELL (M2, M3, M4)	
91	0121F00169	BURNER RACK, 4 CELL (M5, M6, M7, M8)	
91	0121F00170	BURNER RACK, 5 CELL (M9)	
91	0121F00171	BURNER RACK, 6 CELL (M10)	
101	0121F00162	TOP, BURNER BOX 2 CELL (M1)	
101	0121F00759	TOP, BURNER BOX 3 CELL (M2, M3, M4)	
101	0121F00760	TOP, BURNER BOX 4 CELL (M5, M6, M7, M8)	
101	0121F00761	TOP, BURNER BOX 5 CELL (M9)	
101	0121F00762	TOP, BURNER BOX 6 CELL (M10)	
111	10123529	LIMIT-RESET MAN-GREEN (QTY 2)	
121	0121F00146	BURNER BOX SIDE (QTY 2)	
131	0130F00008	SINI IGNITOR	
141	0130F00010	FLAME SENSOR	
151	20162901	LIMIT, PRIMARY (M1)	
151	20162903	LIMIT, PRIMARY (M7, M8, M10)	
151	20162904	LIMIT, PRIMARY (M2, M3, M4, M5, M6, M9)	
161	4028000	ORIFICE PLATE, 2CELL (M1)	
161	4028001	ORIFICE PLATE, 3CELL (M2, M3, M4)	
161	4028002	ORIFICE PLATE, 4 CELL (M5, M6, M7, M8)	
161	4028003	ORIFICE PLATE, 5CELL (M9)	
161	4028004	ORIFICE PLATE, 6CELL (M10)	
171	0154F00003	GASKET-14 INCH (M1, M2)	
171	0154F00004	GASKET-17.5 INCH (M3, M4, M5, M6)	
171	0154F00005	GASKET-21 INCH (M7, M8, M9)	
171	0154F00006	GASKET-24.5 INCH (M10)	
201	DY6.186.070	VENT MOTOR CAPACITOR	
NS	0159F00135	WIRE HARNESS	
NS	0259F00303	WIRE HARNESS ASSY IGNITOR	