

RDF Series Room Temperature Controllers

Product Description

Room Temperature Controllers with LCD for two-pipe (with and without an electrical heater) and four-pipe fan coil units.

Product Numbers

Part Number	Application
RDF10U	Two-pipe fan coil units
RDF20U	Two-pipe fan coil units with electrical heater
RDF30U	Four-pipe fan coil units
RDF50.1U	Two-pipe fan coil units with 0 to 10 Vdc output
RDF60.1U	Two-pipe fan coil units with floating output

Required Tools

- Small, flat-blade screwdriver
- Wire strippers
- Electric drill

Expected Installation Time

30 minutes

Accessories

- 141-570 Lockable Thermostat Guard
- ARG70 Wall Plate Adapter
- QAH11.1 Remote/Changeover Sensor

Installation



Step 1. Loosen retaining screws.

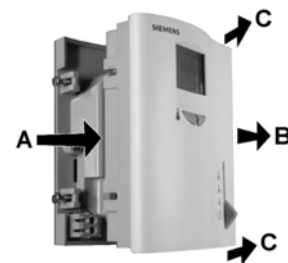

Step 2. Remove controller housing.

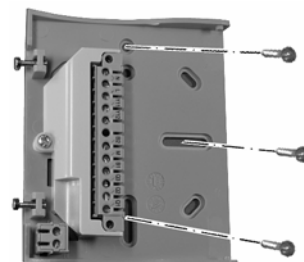

Step 3. Mount base plate to wall.

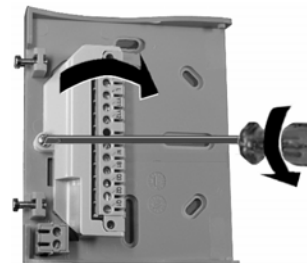

Step 4. Remove screw and open terminal cover.

Installation, Continued



Step 5. Terminate wires (see wiring diagrams), close cover terminal cover and replace screw.

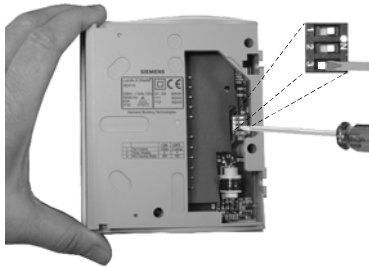

Step 6. Set DIP switches.



Step 7. Replace controller housing.



Step 8. Tighten retaining screws.

The installation is now complete.

Wiring Diagrams

- B1 Remote temperature sensor
- B2 Changeover sensor
- E1 Electric heat
- M1 Three-speed fan motor
- S1 Digital input for day/night changeover
- Y1 Control valve, heat/cool or two-pipe system
- Y2 Cooling control valve for four-pipe system

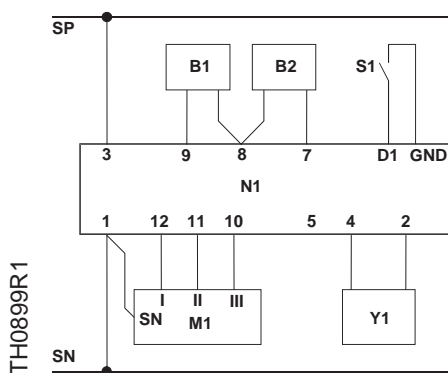

Figure 1. RDF10U.

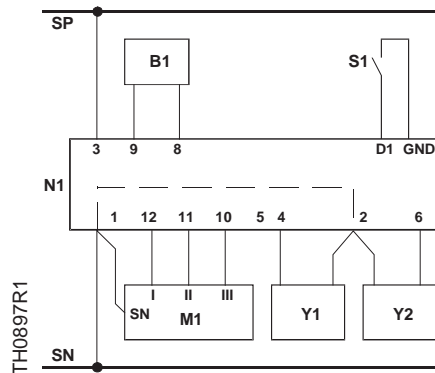

Figure 2. RDF30U.

Terminal Position	RDF10U and RDF30U Terminal Function
1	Operating voltage 24 Vac negative
2	Operating voltage 24 Vac negative
3	Operating voltage 24 Vac positive
4	Heating/cooling output NO
5	Heating/cooling output NC
6	Second stage Heating/Cooling output NO (RDF30U only)
7	Heat/Cool changeover sensor (RDF10U only)
8	Measuring Neutral, remote or changeover sensor
9	Remote air sensor
10,11, 12	Fan Speed output III, II, I
D1, GND	Signal input for potential-free operating mode changeover switch

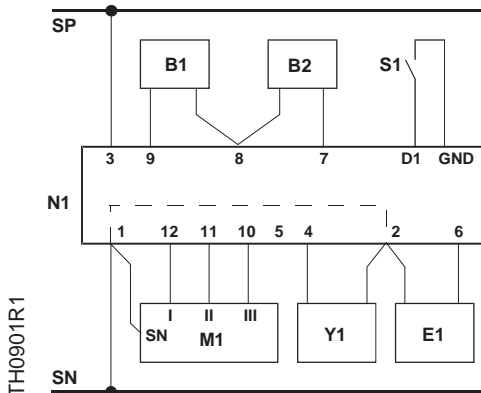

Figure 3. RDF20U.

Terminal Position	RDF20U Terminal Function
1	Ground for control signal
2	Operating voltage 24 Vac negative
3	Operating voltage 24 Vac positive
4	Heating/cooling output NO
5	Heating/cooling output NC
6	Electric heater output NO
7	Heat/Cool changeover sensor
8	Measuring Neutral
9	Remote air sensor
10,11, 12	Fan speed output III, II, I
D1, GND	Signal input for potential-free operating mode changeover switch

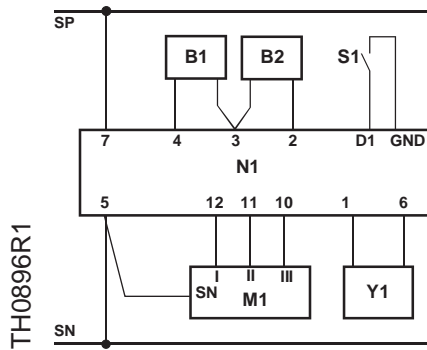

Figure 4. RDF50.1U.

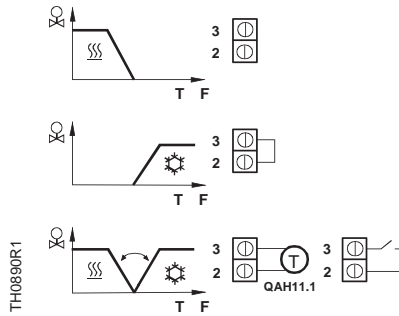

Figure 5. RDF50.1U.

Terminal Position	RDF50.1U Terminal Function
1	0 to 10 Vdc output for valve
2	Heat/Cool changeover sensor
3	Measuring neutral
4	Return air sensor
5	Operating voltage 24 Vac, negative
6	Operating voltage 24 Vac, negative
7	Operating voltage 24 Vac positive
10,11,12	Fan speed output III, II, I
D1, GND	Signal input for potential-free operating mode changeover switch

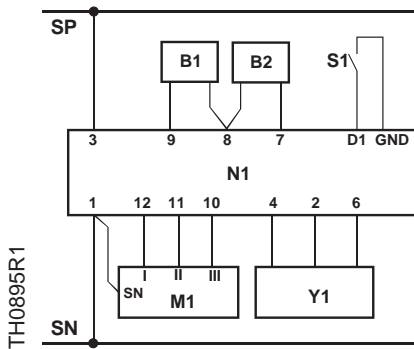

Figure 6. RDF60.1U.

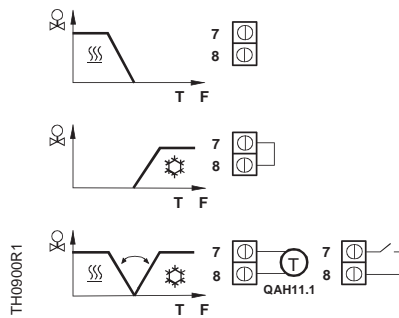

Figure 7. RDF10U, RDF20U, and RDF60.1U.

Terminal Position	RDF60.1U Terminal Function
1	Operating voltage 24 Vac negative
2	Operating voltage 24 Vac positive
3	Operating voltage 24 Vac positive
4	Control signal "Opening" 24 Vac
6	Control signal "Closed" 24 Vac
7	Heat//Cool changeover Input
8	Measuring neutral
9	Remote air sensor
10,11, 12	Fan speed output III, II, I
D1, GND	Signal input for potential-free operating mode changeover switch

Dimensions

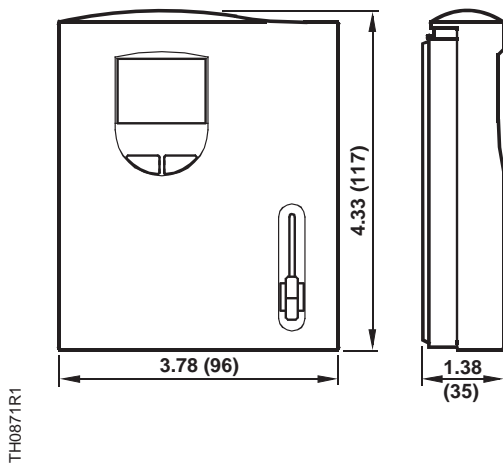

Figure 8. RDF Controller Dimensions in Inches (mm).

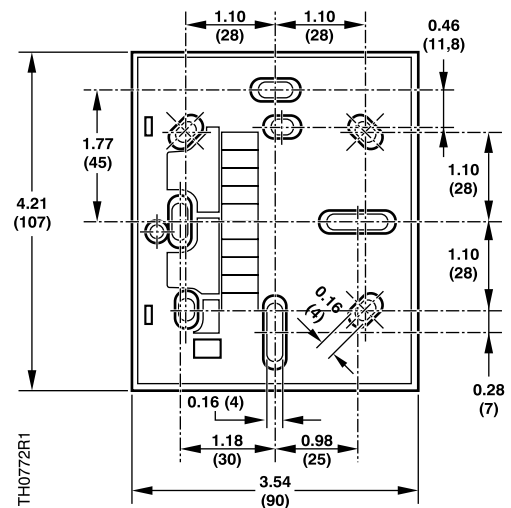
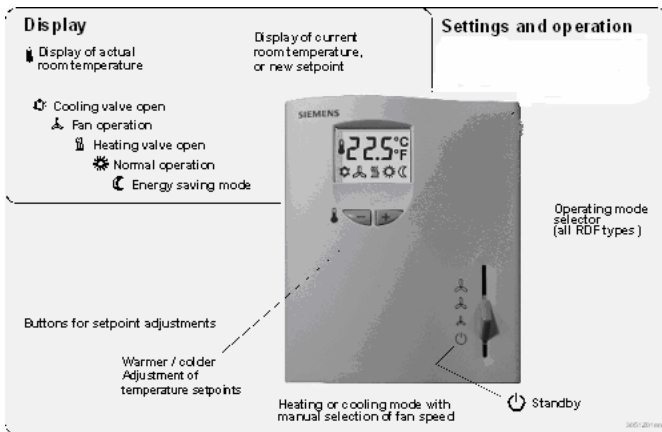

Figure 9. Base Plate Dimensions.

Operating Instructions



Normal Operation



The +/- buttons allow you to increase or decrease the current room temperature setpoint in steps of 1°F (0.5°C).

To do this, proceed as follows:

- Press and hold once. The setpoint display starts flashing.
- Press the buttons again to change the room temperature setpoint in the range 41°F to 95°F (5°C to 35°C). The new temperature setpoint will automatically be stored 10 seconds after the last adjustment is made. The display will then stop flashing.

Changing from Heating to Cooling Mode



Automatic changeover



Display shows that heating valve is open



Display shows that cooling valve is open

Selecting the Three Fan Speeds with the Operating Mode Selector



High



Medium



Low

Changing from Heating or Cooling Mode to Standby



With all RDF types, the operating mode selector is used to manually change from Heating or Cooling mode to Standby .

In Standby , all controller types maintain the adjusted lower heating setpoint P03 or higher cooling setpoint P04.

Changing from Normal Operation to Economy Mode



Changeover from normal operation to Economy mode takes place automatically via an external contact (window switch/remote operation switch, etc.).



Display shows normal operation.



Display shows Economy mode.

Economy Mode

 If you want to change the factory-set temperature setpoints (61°F [16°C] for heating and 82°F [28°C] for cooling), see *Changing the Control Parameters* and *Commissioning*.

Important:

The Economy mode setpoint can be set to 0. This means **OFF** so that the controller is not active in Economy mode and symbol  will not appear.



CAUTION:

When turned **OFF**, the controller will not provide valve control, which could result in freeze conditions.

Changing the Control Parameters



To optimize the control performance, a number of control parameters can be adjusted. Adjustments can be made during operation without opening the controller.

NOTE: For factory settings, see *Commissioning*





To change the parameters for:

- Setpoints for independent heating and cooling in Economy mode
- Setpoints for independent heating and cooling in Standby mode
- Upper and lower limit stops in Normal mode
- Heat/cool changeover points
- Sensor calibration
- Heat/cool switching differentials
- Fan control
- Dead zone between heating and cooling (RDF30U),

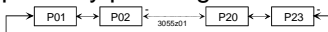
proceed as follows:

-  1. Set operating mode selector to Standby.
-  2. Press the + and – buttons simultaneously for a minimum of 3 seconds and a maximum of 5 seconds. Release them and within 2 seconds, press the + button again for 3 seconds. The display will show “P01”.
-  3. Select the required parameter by repeatedly pressing the + or – button:



-  4. Press the + and – buttons simultaneously, to show the current value of the selected parameter, which can be changed by repeatedly pressing the + or – button.
-  5. Press buttons + and – simultaneously again or wait 5 seconds after the last press of a button, to display the last parameter.
-  6. If you wish to display and change additional parameters, repeat steps 3 through 5.
7. All changes will be stored 10 seconds after the last display or setting.
8. Switch to normal operation  with the operating mode selector.

Recalibrating the Sensor

If the room temperature displayed by the controller does not agree with the actual room temperature, the temperature sensor can be recalibrated by changing parameter P09.



See *Changing the Control Parameters* and follow steps 1 through 3 to select parameter P09.

With step 4, the room temperature displayed can now be matched to the actual room temperature. Each push of the + or – button changes the temperature by +/- 1°F (0.5°C) up to a maximum of +/- 5.5°F (3°C).

With step 7, the recalibration is automatically stored 10 seconds after the last readjustment.

DIP Switch Settings

	Switch Number	Description	Position ON (Factory Setting)	Position OFF
RDF10U, RDF50.1U, and RDF60.1U	1	Fan control	Fan control is temperature-independent in Normal mode	Fan control is temperature-dependent in Normal mode
	2	Temperature or setpoint display	Room (or return air) temperature display	Setpoint display
	3	Operating action of switch for external operating mode changeover	Changeover is activated when switch is closed (NO)	Changeover is activated when switch is open (NC)
RDF20U	1	Fan control	Fan control is temperature-independent in Normal mode	Fan control is temperature-dependent in all operating modes
	2	Temperature or setpoint display	Room (or return air) temperature display	Setpoint display
	3	Operating action of switch for external operating mode changeover	Changeover is activated when switch is closed (NO)	Changeover is activated when switch is open (NC)
	4	Electrical heater	Active in cooling mode	Inactive in cooling mode
RDF30U	1	Fan control	Fan control is temperature-independent in Normal mode	Fan control is temperature-dependent in all operating modes
	2	Temperature or setpoint display	Room (or return air) temperature display	Setpoint display
	3	Operating action of switch for external operating mode changeover	Changeover is activated when switch is closed (NO)	Changeover is activated when switch is open (NC)
	4	Output sequence	Heating and cooling (four-pipe)	Two-stage cooling

Commissioning (by qualified HVAC Installer)

Parameter	Controller's parameter factory settings:	Default settings	Setting range (all settings can be made in increments of 0.5°K)	RDF10U	RDF20U	RDF30U	RDF50.1U	RDF60.1U
P01	Setpoint of heating in night setback (Economy) mode (operating mode changeover switch activated)	61°F (16°C)	OFF, 41°F to 68°F (5°C to 20°C)					
P02	Setpoint of cooling in night setback (Economy) mode (operating mode changeover switch activated)	82°F (28°C)	OFF, 70°F to 95°F (21°C to 35°C)					
P03	Setpoint of heating in Freeze Protection (standby) position	46°F (8°C)	OFF, 41°F to 68°F (5°C to 20°C)					
P04	Setpoint of cooling in standby position	OFF	OFF, 70°F to 95°F (21°C to 35°C)					
P05	Minimum (lower) setpoint limit stop in normal mode	41°F (5°C)	41°F to WmaxNorm (5°C to WmaxNorm)	Legend to table				
P06	Maximum (upper) setpoint limit stop in normal mode	95°F (35°C)	WminNorm to 95°F (WminNorm to 35°C)					
P07	Heat/cool changeover switching point cooling	61°F (16°C)	50°F to 77°F (10°C to 25°C)		Adjustable: please record all changes you make		X	
P08	Heat/cool changeover switching point heating	82°F (28°C)	81°F to 104°F (27°C to 40°C)			X		
P09	Sensor calibration	0 (0 K)	-3 K to +3 K (-5.5°F to 5.5°F)	Not adjustable/display only				
P10	Switching differential in heating mode *	2 K (3.6°F)	1°F to 7°F (0.5 K to 4 K)	x	Not adjustable/no display			
P11	Switching differential in cooling mode *	1 K (1.8°F)	1°F to 7°F (0.5 K to 4 K)					
P12	Integration time	5 minutes	1 to 10 minutes	X	X	X		
	Dead zone in normal operationc *	2 K (3.6°F)	1°F to 18°F (0.5 K to 10 K)	X			X	X
P13	Active temperature sensor (no setting, display only)	-	1: room temperature sensor active 2: return air temperature sensor active					
P14	Value of current room temperature reading (no setting, display only)	-	32°F to 120°F (0°C to 49°C) = current temperature value					
P15	Value of current heat-cool changeover temperature reading including indication of current mode () (no setting, display only)	-	100 = input open (no sensor connected, heating mode) 32°F to 120°F (0°C to 49°C) = current temp. value 00 = input bridged, cooling mode ()			X		
P16	Purging function	0 minutes	0 minutes: not active 1 to 5 minutes active with selected duration			X		
P17	Fan control in energy saving mode OFF: fan is off in the dead zone. ON: fan is on in the dead zone.	OFF	ON: running in selected speed or in speed one if in standby position					
P18	Setpoint differential *	2 K (3.6°F)	1°F to 9°F (0.5 K to 5 K)	X			X	X
	Test mode for checking the actuator direction (note that this parameter can be quit only if the setting is back at "----" and by pressing buttons + and – simultaneously)	---	"----" = no signal on outputs Y1 and Y2 OPE = output Y1 forced open CLO = output Y2 forced closing	X	X	X	X	
P19	Minimum output on-time	1 minute	1 to 20 minutes (in increments of 1 minute)				X	X
P20	Minimum output off-time	1 minute	1 to 20 minutes (in increments of 1 minute)				X	X
P21	Fan overrun	see list	0 to 300 seconds (in increments of 10 seconds)	X	(60s)	(0 s)	X	X
P22	Point of reference for setpoint in Normal mode	HA	HA: heating sequence CL: cooling sequence	X			X	X
P23	Display unit of measurement	°F	°F °C					

* Note: This parameter is in degrees Kelvin, 1°K = 1.8°F).

Information in this publication is based on current specifications. The company reserves the right to make changes in specifications and models as design improvements are introduced. Teflon is a registered trademark of DuPont. Other product or company names mentioned herein may be the trademarks of their respective owners. © 2006 Siemens Building Technologies, Inc.