

LR-1500 UNDERSINK LEAD FILTRATION SYSTEM



APPLICATIONS

- ◆ Undersink

FEATURES • BENEFITS

- ◆ Professional-grade lead reduction drinking water system
- ◆ NSF/ANSI Standard 42 & 53 certified to reduce lead
- ◆ Full flow technology means no separate faucet required
- ◆ Complete system with wrench, integrated mounting bracket, and manual

INSTALLATION TIPS

- ◆ Choose a mounting location suitable to support the full weight of the system when operating.
- ◆ Make sure to properly lubricate O-ring prior to use.
- ◆ Use 3/8" quick connect water line.
- ◆ Install vertically with bowl hanging down.
- ◆ Allow 2-1/2" (6.35 cm) clearance below the cartridge for easy cartridge replacement.

OPERATION TIPS

- ◆ Replace cartridge if flow rate decreases.
- ◆ Do not exceed service flow rate.
- ◆ Inspect O-ring during each cartridge change. Lubricate and/or replace if necessary.

SIZING

- ◆ Service Flow Rate: Maximum 2.5 gpm

INCLUDES

- ◆ 10" standard filter housing with integrated mounting bracket cap
- ◆ 10" filter cartridge
- ◆ Wrench
- ◆ Installation kit
- ◆ Installation and operation manual

LR-1500 UNDERSINK LEAD FILTRATION SYSTEM

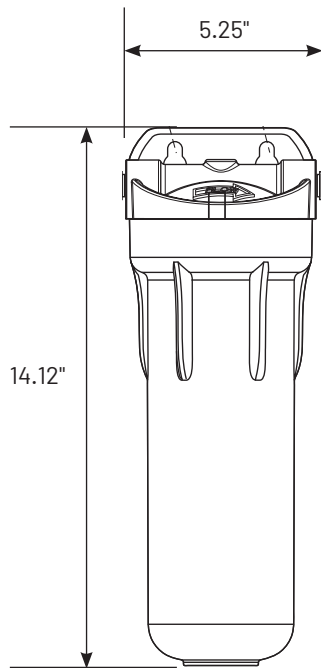

SPECIFICATIONS

- ◆ **System (Model/Part No.)**
LR-1500 / 160406
- ◆ **Housing Size**
10" Standard
- ◆ **Inlet Size**
3/8" QC
- ◆ **Housing Material**
Polypropylene
- ◆ **System Dimensions**
14.12" H x 5.25" W
(358.64 mm x 133.35 mm)
- ◆ **Cartridge Type**
Fibredyne[®] Carbon Block
- ◆ **Contaminant Reduction**
Lead: NSF/ANSI Standard 42 & 53
- ◆ **Micron Rating**
0.5
- ◆ **Approximate Filter Life***
1 Year
- ◆ **Capacity**
1,500 gallons (5,678 liters)
- ◆ **Flow Rate**
2.5 gpm (9.46 Lpm)
- ◆ **Certification**
NSF/ANSI Standard 42 & 53
CSA Standard B483.1
- ◆ **Feed Pressure Range**
40 - 125 psi (2.75 - 1.03 bar)
- ◆ **Temperature Range**
40° - 100°F (4.4 - 37.8°C)
- ◆ **Replacement Cartridge**
(Model/Part No.)
LR-FB10 / 655208-43 (12/case)

* Filter life dependent on gallon usage and overall incoming water quality



The Model LR-1500 is Tested and Certified by NSF International against NSF/ANSI Standard 42, 53 and CSA B483.1 for the reduction of the claims specified on the Performance Data Sheet.



13845 Bishops Dr. | Suite 200 | Brookfield, WI 53005 | United States
P: 262.238.4400 | Customer Service: 800.279.9404 | tech-support@pentair.com | pentair.com

All indicated Pentair trademarks and logos are property of Pentair. Third party registered trademarks and logos are the property of their respective owners.

© 2023 Pentair. All rights reserved.

4005275 JA23