

Series SC/SCT™

Semi-Commercial Boilers



Standard Equipment

- > High Efficiency Power Burners*
- > Honeywell Operating Controls
- > Manual Reset High Limit Control
- > Low Water Cutoff on Packaged Boilers
- > Top Flue Outlet—Includes Locking Damper
- > Steel Push Nipples—Provides a Water Tight Seal Between Sections
- > Deluxe Insulated Enameled Steel Jacket
- > Optional Tankless Coils—For Domestic Hot Water

*choice of Beckett, Carlin, Power Flame, Midco or Webster

Series SC/SCT™ Boiler Features

- Semi-Commercial, Oil, Gas or Combination Gas/Oil-fired Boilers
- Constructed of Rugged, Cast Iron, Wet-Base Sections
- 6 Sizes, 5–10 Sections for Hot Water or Steam Systems
- Forced Draft Venting Requires Only a Three Foot Vent Above the Roof
- Meets and/or Exceeds the ASHRAE 90.1 Minimum as Required by the Federal Standards for Commercial Boilers

All commercial cast iron boilers include a full one-year warranty. A limited, ten-year warranty is provided on the cast iron sections for all commercial hot water and steam boilers. Visit PeerlessBoilers.com for complete details.

Steam Piping

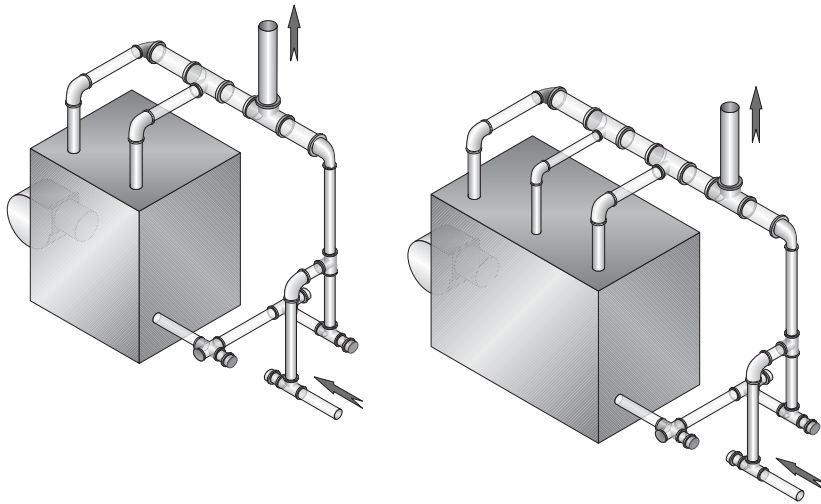

The return from the system should always enter equalizer through Hartford Loop, 2" to 4" below water line.

Water Piping

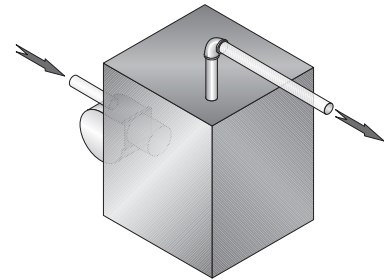

The supply and return connections should be sized to suit the system. The supply should be piped out of the top of the back section and the return piped to the bottom of the front section. There is a 3/4" tapping in the top of the back section for air elimination.

Boiler Piping

Boiler Model Number	Risers	Header	Equalizer
SC/SCT-05	2 - 2"	3"	1-1/2"
SC/SCT-06	2 - 2"	4"	1-1/2"
SC/SCT-07	2 - 2-1/2"	4"	1-1/2"
SC/SCT-08	2 - 2-1/2"	4"	1-1/2"
SC/SCT-09	2 - 2-1/2"	4"	2"
SC/SCT-10	2 - 2-1/2" and 1 - 2"	4"	2"

Burner Specifications

Boiler Model Number	Burners - Oil				Burners - Gas				Burners - Gas/Oil	
	Beckett	Carlin	Power Flame	Webster	Beckett	Midco	Power Flame	Webster	Power Flame	Webster
	Model No.	Model No.	Model No.	Model No.	Model No.	Model No. ¹ No. ²	Model No.	Model No.	Model No.	Model No.
SC/SCT-05	CF500	201CRD	CR1-O	N/A	CG10.1	RE6850/B	JR15A/CR1-G	N/A	CR1-GO	N/A
SC/SCT-06	CF500	201CRD	CR1-O	N/A	CG10.3	RE6850/B	JR15A/CR1-G	N/A	CR1-GO	N/A
SC/SCT-07	CF800	201CRD	CR1-O	N/A	CG10.3	RE6850/B	JR15A/CR1-G	N/A	CR1-GO	N/A
SC/SCT-08	CF800	201CRD	CR1-O	JB1-O	CG10.4S	RE6850/B	JR30A/CR1-G	JB1-G	CR1-GO	JB1-C
SC/SCT-09	CF800	301CRD	CR1-O	JB1-O	CG10.4S	RE6850/B	JR30A/CR1-G	JB1-G	CR1-GO	JB1-C
SC/SCT-10	CF800	301CRD	CR1-O	JB1-O	CG10.5S	RE6850/B	JR30A/CR1-G	JB1-G	CR1-GO	JB1-C

¹ RE6850 indicates a Honeywell RM7895A 120 VAC Control

² RE6850B indicates a Honeywell S8680J 24 VAC Control

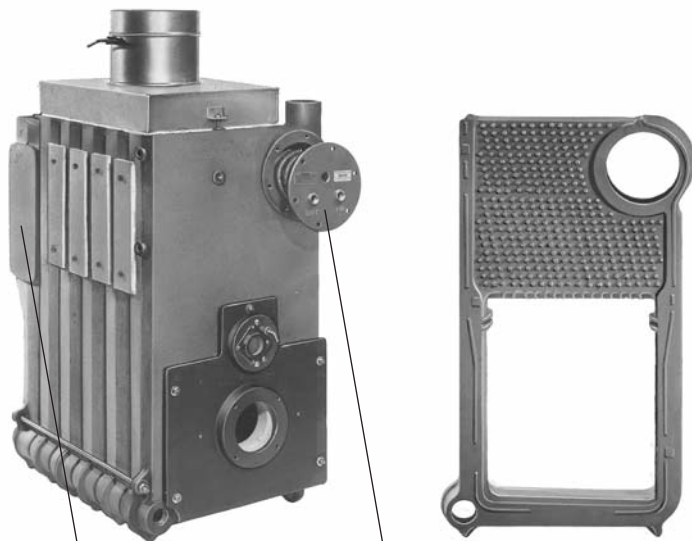

Tankless Copper Water Heater is located in the rear section when installed on a Steam Boiler.

Tankless Copper Water Heater is located in the upper front nipple port when installed on a Hot Water Boiler.

Both Heaters may be installed on a Water Boiler when a greater volume of Domestic Hot Water is desired.

Control Locations

Location	Size N.P.T.	Steam	Water
H	3/4"	Low Limit Control	N/A
J	3/4"	Press. Gauge, Oper. Cont. & Limit Cont.	Operating Control
K	3/4"	N/A	Limit Control
L	1/4"	N/A	Theraltimeter
M	1/2"	Gauge Glass & Low Water Cutoff	N/A
N	2"	Return	Optional Return
O	3/4"	Secondary Probe Low Water Cutoff	Secondary Probe Low Water Cutoff
P	3/4" (05-06) 1" (07-10)	Safety Valve	Relief Valve
Q	1-1/4" (05-06) 1-1/2" (07-10)	Return	Return
R	3/4"	Drain Cock	Drain Cock
S	1-1/2"	Skim Tapping & Alternate Safety Valve	Optional High Limit
T	3/4"	Primary Probe Low Water Cutoff	N/A
V	1"	Opt. Float LWCO	Opt. Float LWCO

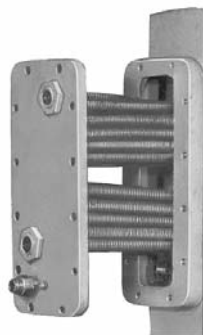

Htr X-1082



Htr X-1020
Htr X-1021
Htr X-1022

Optional Tankless Domestic Hot Water Heaters

Boiler Model Number	Htr. X-1020 GPM	Htr. X-1021 GPM	Htr. X-1022 GPM	Htr. X-1082* GPM (Steam)
SC-05	4.75	—	—	4.75
SC-06	5.00	6.00	—	5.00
SC-07	5.25	6.50	—	5.25
SC-08	5.50	7.00	10.00	5.50
SC-09	5.75	7.50	11.00	5.75
SC-10	6.00	8.00	12.00	6.00

*Optional tankless coil available for the SCT boiler only.
Water heater ratings are based on intermittent demand—40°F to 140°F rise with 200°F boiler water.



Technical Information

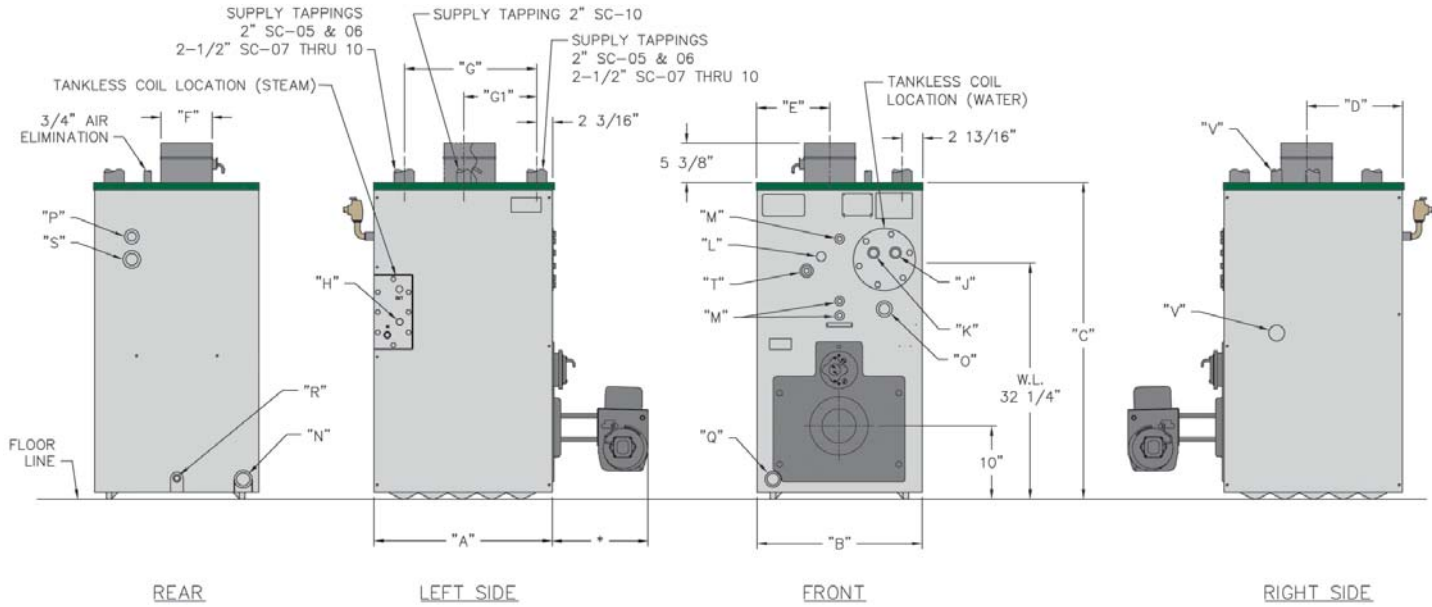

Note: Maximum burner length: Beckett = 13-1/2", Power Flame C = 34", Power Flame J = 24", Webster JB-1 = 30", Midco RE6850 = 21".

Boiler Dimensions

Boiler Model Number	Jacket			Rear of Jacket to c/l of Flue "D"	Left of Jacket to c/l of Flue "E"	Flue Size "F"	Approx. Dist. Between Tappings "G"	Approx. Dist. Between Tappings "G1"
	Depth "A"	Width "B"	Height "C"					
SC/SCT-05	24-1/2"	22-1/2"	43-1/4"	13-1/4"	10"	7"	17-7/16"	—
SC/SCT-06	28-3/4"	22-1/2"	43-1/4"	15-3/8"	10"	9"	21-5/8"	—
SC/SCT-07	33"	22-1/2"	43-1/4"	17-1/2"	10"	9"	25-13/16"	—
SC/SCT-08	37-1/4"	22-1/2"	43-1/4"	19-5/8"	10"	9"	30"	—
SC/SCT-09	41-1/2"	22-1/2"	43-1/4"	21-3/4"	10"	10"	34-3/16"	—
SC/SCT-10	45-3/4"	22-1/2"	43-1/4"	23-7/8"	10"	10"	38-3/8"	17-1/8"

Carton Dimensions & Shipping Weights

Boiler Model Number	Approximate Shipping Weight* (lbs.)
SC/SCT-05	815
SC/SCT-06	910
SC/SCT-07	1005
SC/SCT-08	1100
SC/SCT-09	1195
SC/SCT-10	1280

* Based on Standard Oil Burner

Boiler Ratings

Series SC/SCT™												AHRI CERTIFIED™ www.ahridirectory.org		
Boiler Model Number	Oil Input		Gas Input, MBH	Gross Output, MBH	Net Ratings			Thermal Efficiency, %		Combustion Efficiency, %		Boiler H.P.	Water Content, gal	
	GPH	MBH			Steam, sqft	Water, MBH	Steam, MBH	Oil	Gas	Oil	Gas		Water	Steam
	SC/SCT-05	2.80	392	404	327	1,022	284	245	83.4	80.9	85.4	82.8	9.8	26.04
SC/SCT-06	3.50	490	505	409	1,278	356	307	83.5	81.0	85.4	82.8	12.2	30.36	23.52
SC/SCT-07	4.00	560	577	468	1,463	407	351	83.6	81.1	85.3	82.8	14.0	34.68	26.64
SC/SCT-08	4.50	630	649	527	1,647	458	395	83.6	81.1	85.3	82.8	15.8	39.03	29.76
SC/SCT-09	5.00	700	722	586	1,832	510	440	83.7	81.2	85.3	82.7	17.5	43.32	32.88
SC/SCT-10	5.50	770	794	645	2,016	561	484	83.8	81.2	85.3	82.7	19.3	47.64	36.00

The above ratings are based on 12.75% CO₂ (oil) and +.10 in. W.C. at the vent.

The Net Ratings shown include allowance for normal piping and pickup load in accordance with AHRI requirements. Water ratings are based on a piping and pickup allowance factor of 1.15. Steam ratings based on an allowance factor of 1.33. PB Heat should be consulted before selecting a boiler for gravity hot water installations and installations having unusual piping and pickup requirements such as extended piping systems, exposed piping, night set-back, etc. Ratings shown are for elevations up to 2,000 feet. For elevations above 2,000 feet ratings should be reduced at the rate of 4 percent for each 1,000 feet above sea level.

Oil Burner Input is based on G.P.H. with a heating value of 140,000 BTU/gal. Burner Input based on maximum altitude of 2,000 ft.—for other altitudes consult factory.



PeerlessBoilers.com



Printed on Recycled Paper

PeerlessBoilers.com

CUT-SC R2 (12/15-1M)
Printed in U.S.A.
©2015 PB Heat, LLC. All rights reserved.