

Specification Submittal Data: BalancedHome™ 210 Elite Plus+ (FV-21VEC1T)

Description:

The BalancedHome™ Elite Plus+ Energy Recovery Ventilator (ERV) provides tempered supply air to the home while exhausting stale indoor air. Independent supply and exhaust settings ranging from 40 to 210 CFM; provide balanced ventilation while recovering energy from the exchanged air, with an occupant-controlled boost up to 210 CFM. This Energy Recovery Ventilator is engineered for use in any North American climate zone.

Motor/Blower:

- Two (2) DC-enclosed ECM brushless motors rated for continuous run
- Power rating 120V/60hz, 3.1 amps
- Power cord equipped, hardwire adaptor kit included
- Supply and Exhaust CFM rates adjustable from 40-210 CFM
- Motor equipped with thermal protection
- Built-in ASHRAE 62.2 timing function for code compliance

Housing:

- Galvanized, corrosion-resistant steel body
- Four 6" vertically oriented ducts for supply, exhaust, room air, and room return air
- Chain mounts and wall mounts with predrilled mounting brackets included

Maintenance:

- MERV 13 filter included (FV-FL1321VE1)
- Replacement washable MERV 6 available (FV-FL0621VE1)
- Visual and Audible filter replacement indicators activate after 90 days of accumulated run time
- California Energy Commission (CEC) certified Fault Indication Device (FID) alerts occupants to check for maintenance and installation issues

Warranty:

- ECM Motors: 6 years from the original purchase date
- All other parts: 3 years from the original purchase date

Architectural Spec:

ERV shall be ceiling or wall mount type with LED display speed selectors for supply and exhaust air. CFM shall be selectable from 40-210 CFM. ERV shall have 220 Gross CFM on the exhaust ports and 220 Gross CFM on the supply ports as tested under CSA-C439 standards at 0.4 static pressure in inches water gauge. ERV shall have Occupant Controlled Boost Capability.

ERV shall have a fault indicator device* to notify occupants of system issues. Power consumption shall be no greater than 115 watts at 0.2" w.g. static pressure at 163 CFM. Sensible Recovery Efficiency for heating shall be no less than 83% at 42 CFM net airflow at 32°F, [0°C]. Adjusted Sensible Recovery Efficiency for heating shall be no less than 86% at 42 CFM net airflow at 32°F [0°C]. Total Recovery Efficiency for cooling shall be no less than 74% at 68 CFM net airflow at 95°F [35°C]. When temperatures are within freezing, the unit will have the option to either recirculate or exhaust the air based on preset settings. The (2) motors shall be enclosed ECM brushless motors rated for continuous run. ECM motor speed shall automatically increase when the fan senses static pressure to maintain the selected CFM. ERV shall incorporate an ASHRAE 62.2 intermittent and continuous timing function for code compliance. The power rating shall be 120v/60Hz, 3.1 amps, and shall be equipped with a standard power cord and include a hardwire adapter kit with the unit. Duct diameters shall be no less than 6". ERV must include vertical supply and return air adapters. ERV can be used to comply with ASHRAE 62.2, Ontario Building Code, and ENERGY STAR® requirements; LEED, Indoor airPLUS, California Title-24, and 2021 Washington State Residential Energy Code.

ERV Core Technology:

- Indoor and outdoor air passes through Panasonic's hygroscopic membrane core. This process tempers supply air while transferring moisture and energy.
- Mold resistant core material for long-lasting performance
- Built-in Frost Prevention Mode helps prevent the core from freezing

* Wall Control/Fault Indicator Display (FID) FV-SCVE2 (sold separately).

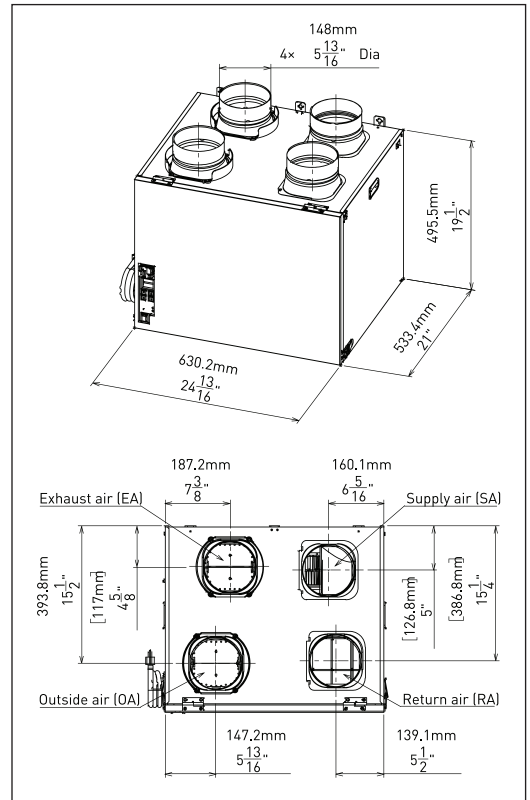

FV-21VEC1T

For complete Installation Instructions visit iaq.na.panasonic.com

Model	Quantity	Comments	Project:
			Location:
			Architect:
			Engineer:
			Contractor:
			Submitted by:
			Date:

Specification Submittal Data: BalancedHome™ 210 Elite Plus+ (FV-21VEC1T)
 (Continued)

FV-21VEC1T												
Energy Performance												
Mode	Outdoor Temp		Net Air Flow		Power Consumed	Sensible Recovery Efficiency	Adjusted Sensible Recovery Efficiency	Total Recovery Efficiency	Adjusted Total Recovery Efficiency	Latent Recovery / Moisture Transfer	Apparent Sensible Effectiveness (NOT HVI Certified)	CFM/W
	°C	°F	L/S	CFM	Watt							
Heating	0	32	20	42	21	83	86	-	-	0.79	91	2.0
	0	32	31	66	28	81	84	-	-	0.70	88	2.3
	0	32	38	81	35	80	83	-	-	0.68	86	2.3
	0	32	77	163	115	74	78	-	-	0.59	80	1.4
-25°C	-25	-13	33	70	76	58	60	-	-	0.52	79	0.9
	-25	-13	29	61	58	67	69	-	-	0.62	87	1.0
Cooling	35	95	32	68	30	-	-	74	76	0.75	83	2.2
	35	95	39	83	37	-	-	72	74	0.73	82	2.2
	35	95	76	161	124	-	-	61	64	0.61	74	1.2

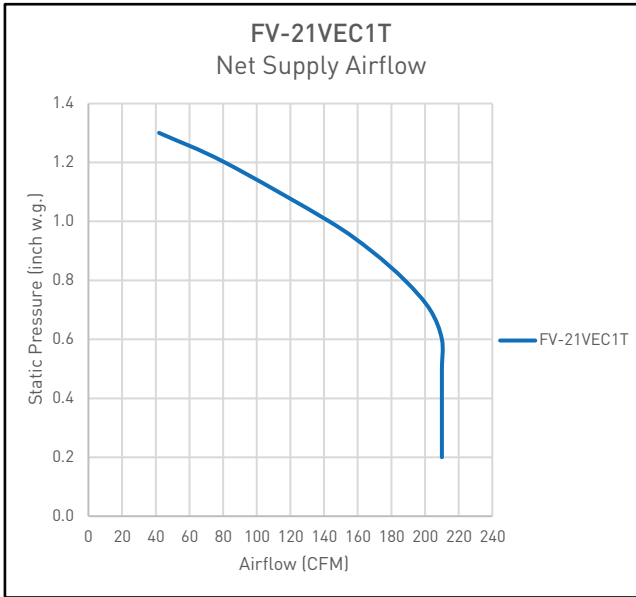

Panasonic
IAQ Division
 Two Riverfront Plaza
 Newark, NJ 07102
iaq.na.panasonic.com



*This product meets strict energy efficiency guidelines set by Natural Resources Canada and is ENERGY STAR® certified for the Canadian market only. There are no current Energy Star ratings for Energy Recovery Ventilators in the US market.