

## Split System Submittal Data

System: **26PEF2U6** Indoor: **S-26PF2U6** Outdoor: **U-26PE1U6**  
 Single Split System - Concealed Duct Heat Pumps

Job Name: \_\_\_\_\_  
 Location: \_\_\_\_\_  
 Engineer: \_\_\_\_\_  
 Submitted to: \_\_\_\_\_  
 Submitted by: \_\_\_\_\_  
 Reference: \_\_\_\_\_

Approval: \_\_\_\_\_  
 Date: \_\_\_\_\_  
 Construction: \_\_\_\_\_  
 Unit#: \_\_\_\_\_  
 Drawing#: \_\_\_\_\_

General Data	
<b>Power (V/P/Hz)</b>	<b>230/208/1/60</b>
Circuit Ampacity (A)	15-30 Indoor-Outdoor
Fuse Size, Max.(A)	15-30 Indoor-Outdoor
<b>Compressor</b>	<b>DC Rotary Inverter</b>
No. Used	1
R.L. Amps - L.R. (A)	12.9 - 17.5
Outdoor Unit	
Fan type	Propeller
Dia & Length (in.) - No. used	18-7/64-1
Type Drive - No. Speeds	Direct - Inverter
No. Poles (RPM)	8 - 800
No. Motors (W)	1 - 90
CFM (High)	1765
F.L. Amps (A)	13.8
<b>Coil Type</b>	<b>Aluminum Fin &amp; Copper Pipe</b>
Fin Type - Pipe Type	Slit Plate - Inner Rifled
Rows - F.P.I.	1 - 15.9
Face Area (sq.ft.)	7.26
Tube Size (in)	3/8" / 5/8"
Indoor Unit	
Fan Type	Sirocco
Dia & Length (in.) - No. used	7-9/32 2
No. Speeds	3 & Auto
No. Poles (RPM, High)	8p 1360
No. Motors (W)	1-124
CFM (Hi/Med/Lo)	742/671/530
Indoor Sound Rating (Hi) (dB-A)	35
F.L. Amps (A)	0.8
<b>Coil Type</b>	<b>Aluminum Plate Fin &amp; Copper Tube</b>
Fin Type - Pipe Type	Slit Plate - Inner Rifled
Rows - F.P.I.	3-3/64" (1.34mm)
Face Area sq.ft. (M2)	2.90 (0.269)
Tube Size (in)	9/32"
Drain Connection Size	Max. head 1.64ft above drain connection



<b>Refrigerant</b>	<b>R410A</b>
Lbs. - R410a	4.2
Control	Electric Expansion Valve
Connection	Flare
Line Length, Max (ft.)	165
Line Difference, Max (ft.)	50 (outdoor lower), 100 (outdoor higher)
Line Size (in. O.D. Discharge)	3/8"
Line Size (in. O.D. Suction)	5/8"
Dimensions (HxWxD)	
Indoor Unit (Crated) (in.)	14-3/32 x 46-7/8 x 30-13/16
Indoor Unit (Uncrated) (in.)	11-7/16 x 39-3/8 x 27-19/16
Outdoor Unit (Crated) (in.)	34-31/32 x 39-31/32 x 16-3/32
Outdoor Unit (Uncrated) (in.)	30-23/32 x 37 x 13-3/8
Weight (lbs.)	
(Indoor) Net	73
(Indoor) Shipping	89
(Outdoor) Net	128
(Outdoor) Shipping	148
(Indoor) Shipping Volume (cu.ft.)	12.94
(Outdoor) Shipping Volume (cu.ft.)	13

### Performance Data @ ARI Standard Conditions (230/208V)

Cooling	
Total Capacity (BTU/H)	24,000 (9,500 - 24,000)
Sensible Capacity (BTU/H)	N/A
Latent Capacity (BTU/H)	N/A
SEER	16.2
Dehumidification (Pints/H)	4.6
Amps (A)	14.2/15.6
Power Inputs (W)	2720/2720
Outdoor Sound Rating (dB-A) High	49
Heating	
Total Capacity (BTU/H)	28,600 (8,000 - 28,600)
HSPF	9.8
Amps (A)	12.5/13.8
Max Amps (A)	12.5/13.8
Power Inputs (W)	2720/2720
Back-up Strip Heater (KW)	N/A
Outdoor Sound Rating (dB-A) High	49

### Features

Controls	Microprocessor
Remote Controller	(Wired Included) (Wireless Optional)
Temperature Control	IC Thermostat
Timer	72 HR, ON/OFF
Night Setback	N/A
Air Louver, Horizontal	N/A
Air Louver, Vertical	N/A
Power Failure Automatic Changeover	Built-In
Heating/Cooling Automatic Changeover	Built-In
Self-Diagnosis	Built-In
Air Filter	Field Provided

### Option

Refrigerant Line Set	Available
Fresh Air Intake	N/A
Condensate Drain Pump	Built In (1.64ft)
Wireless Remote Controller	Optional
Non-Removable Remo-con Bracket	Available

### Operating Range

Operating Range	Indoor Air Intake Temp	Outdoor Air Intake Temp
Cooling (Max)	95F DB/71F WB	115F DB
Cooling (Min)	67 DB/57F WB	0F DB
Heating (Max)	80F DB/67F WB	75F DB/65F WB
Heating (Min)	-DB/-WB	(-)-4F DB



# Indoor Dimensions

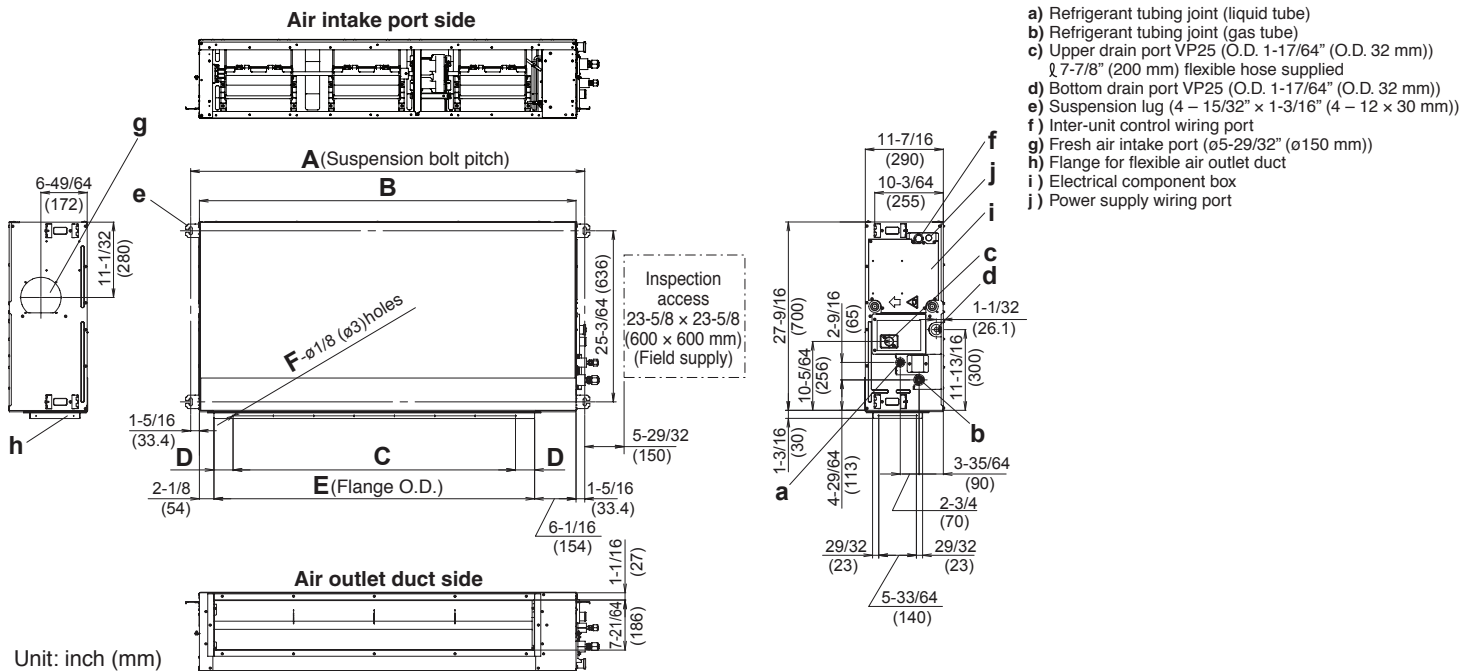
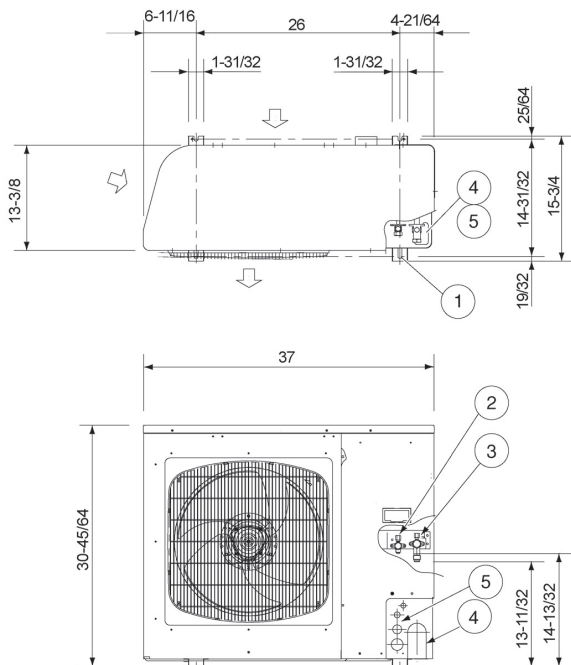

Table 3-2

Type		A	B	C	D	E	F
26	inch	42-1/64	39-3/8	29-17/32 (Pitch 5-29/32 x 5)	53/64	31-3/16	16
	mm	1,067	1,000	750 (Pitch 150 x 5)	21	792	
36	inch	57-3/4	55-1/8	41-11/32 (Pitch 5-29/32 x 7)	2-51/64	46-59/64	20
	mm	1,467	1,400	1,050 (Pitch 150 x 7)	71	1,192	

# Outdoor Dimensions



①	Hole for anchor bolt (4-R6.5) / Anchor bolt: M10
②	Refrigerant tube joint (liquid line tube) • Flare connection 3/8 in (9.52 mm)
③	Refrigerant tube joint (gas line tube) • Flare connection 5/8 in (15.88 mm)
④	Refrigerant tubing inlet (knock-out hole)
⑤	Power supply inlet (knock-out hole $\varnothing$ 38, $\varnothing$ 29, $\varnothing$ 19, $\varnothing$ 16 mm)

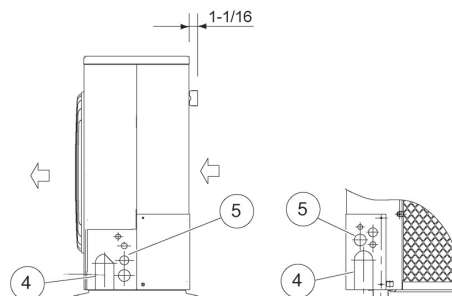

Dimension: inch

# Panasonic

Panasonic North America  
 Air Conditioning Division  
 1690 Roberts Blvd., NW, Suite 110  
 Kennesaw, GA 30144  
 us.panasonic.com/aircon