

Service Manual

Energy Recovery Ventilator

FV-15VE1T

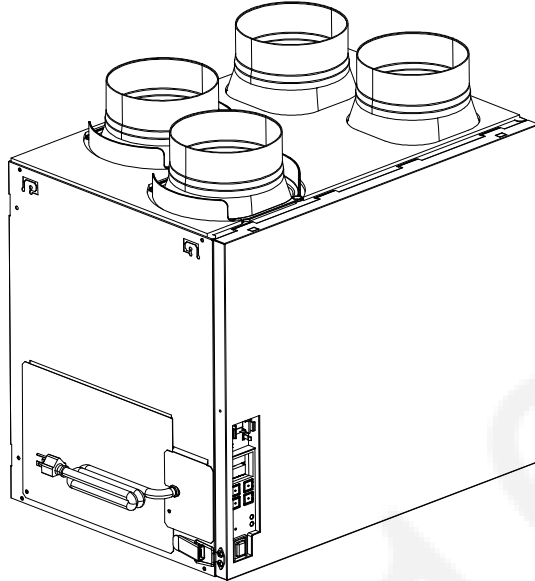

⚠ WARNING

This service information is designed for experienced repair technicians only and is not designed for use by the general public. It does not contain warnings or cautions to advise non-technical individuals of potential dangers in attempting to service a product. Products powered by electricity should be serviced or repaired only by experienced professional technicians. Any attempt to service or repair the product or products dealt with in this service information by anyone else could result in serious injury or death.

IMPORTANT SAFETY NOTICE

There are special components used in this equipment which are important for safety. These parts are marked by ⚠ in the Schematic Diagrams, Exploded Views and Replacement Parts List. It is essential that these critical parts should be replaced with manufacturer's specified parts to prevent shock, fire or other hazards. Do not modify the original design without permission of manufacture.

We suggest to handle such parts after the static electricity prevention.

It is forbidden to touch the PCB parts by bare hands during the repairing process.

CONTENTS	PAGE
1.Specifications	1
2.Parts Identification	2~6
3.Wiring Diagram	7
4.Maintenance	8~9
5. Troubleshooting	10~11
6.Parts List	12~13

1. Specifications

<Ventilation Performance>

Model No.	Voltage (V)	Frequency (Hz)	Duct	Static pressure	Net air flow (CFM)		Power consumption (W)	Weight lb.(kg)
					Exhaust	Supply	Fan unit	
FV-15VE1T	120	60	6"	0.1"WG	150	150	102	45 (20.4)
				0.4"WG	150	150	130	

<Energy Performance>

Model No.	Mode	Supply temperature		Net air flow		Power consumption (W)	Sensible recovery efficiency	Adjusted sensible recovery efficiency	Net moisture transfer
		°F	°C	L/s	CFM				
FV-15VE1T	Heating	32	0	17	36	20	77	79	0.67
		32	0	31	66	33	73	75	0.58
		32	0	71	150	98	64	66	0.50
	Cooling	Total recovery efficiency							
		95	35	17	36	23	70		
		95	35	31	66	37	64		
95	35	57	120	102	53				

The testing of the ventilation performance and the energy performance is in accordance with CSA-C439-18 standard.

2. Parts Identification

FV-15VE1T

Main Body Section

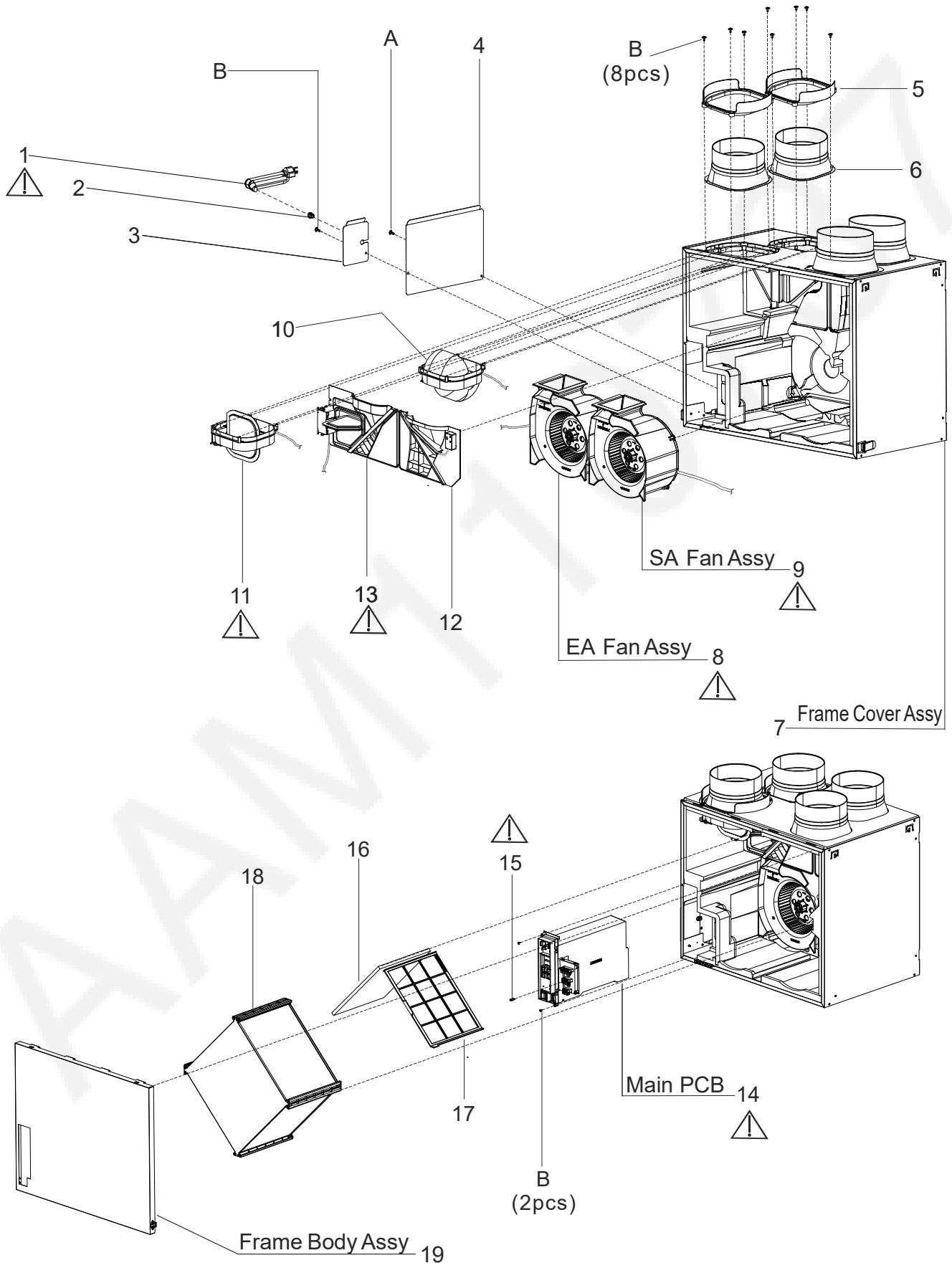

2. Parts Identification

FV-15VE1T

Frame Body Assy

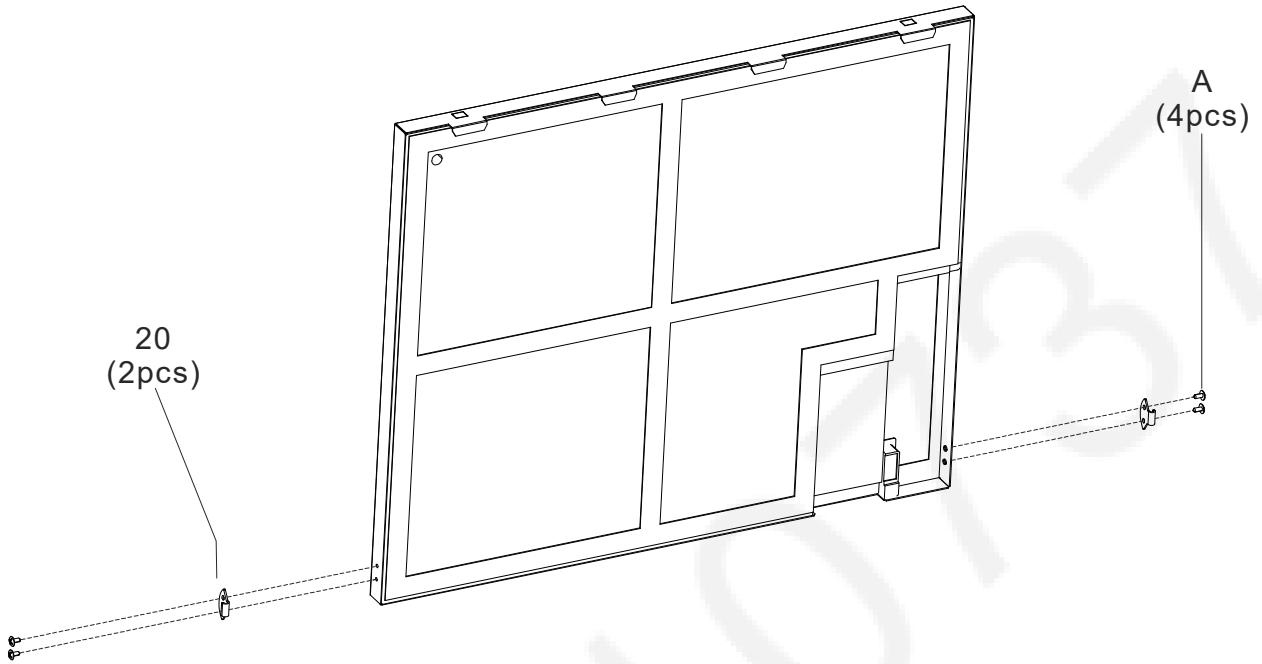

SA Fan Assy / EA Fan Assy

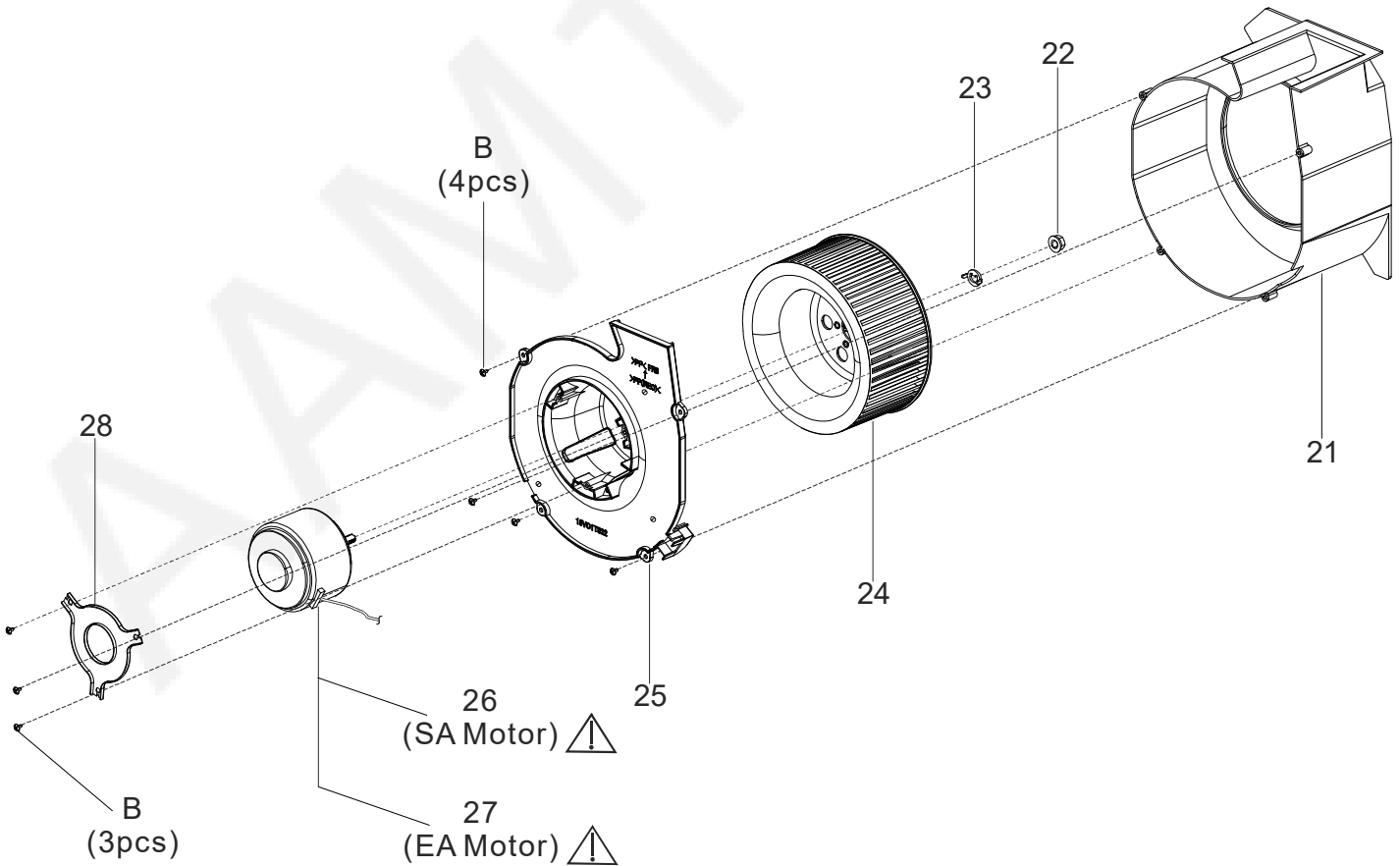

2. Parts Identification

FV-15VE1T

Frame Cover Assy

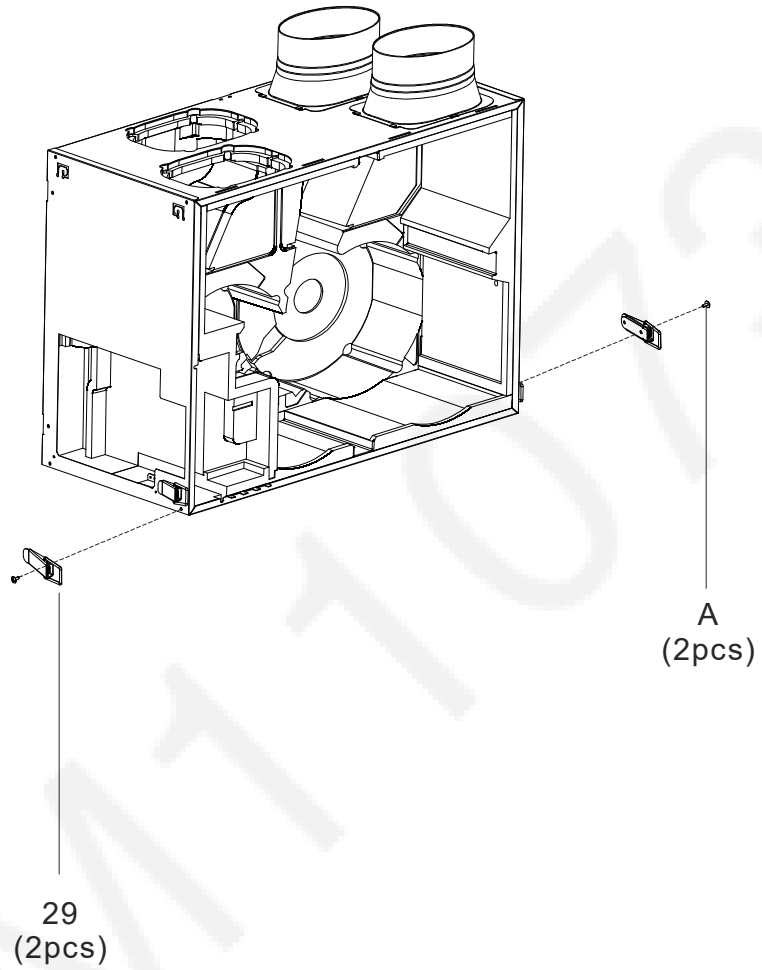

2. Parts Identification

FV-15VE1T

Main Labels

CAUTION

- Electric shock may result. Disconnect power by switching off main switch first, then unplug before working on unit when it is in default mode. (Fig.1)
- Electric shock may result. Disconnect power by switching off wall switch first, then main switch and unplug before working on unit when replacing the jumper cable with wall switch.
- The installation direction should refer to Fig.2 when wall mounting.
- Routine maintenance must be performed every 2 or 3 months, clogged filters may cause condensation on the unit due to air flow reduction.
- Please wear gloves to avoid pinching fingers during maintenance.
- Please pay attention to dust, condensation water or parts that may drop down when the cover is opened.

MAINTENANCE PROCEDURE

- Open the frame cover by unlocking the latches. If not convenient for maintenance you also can remove the frame cover. (Fig.3)
- Remove OA filter and RA filter to clean with vacuum cleaner. (Fig.4)
- Clean energy recovery core with vacuum cleaner. (Fig.5)
- Replace the OA and RA filters. Make sure the direction of the arrow on the OA filter is correct. (Fig.6)
- Reinstall and close frame cover by locking the latches. (Fig.7)
- Connect power, press filter reset button with sound of "beep" then filter indicator and buzzer sound will be off. (Fig.8)

ATTENTION

- Risque de choc électrique. Coupez l'alimentation avec l'interrupteur principal d'abord, puis débranchez avant de travailler sur l'appareil lorsqu'il est en mode par défaut. (Fig.1)
- Risque de choc électrique. Coupez l'alimentation avec l'interrupteur mural d'abord, puis l'interrupteur principal et débranchez avant de travailler sur l'appareil pour remplacer la connexion temporaire par un interrupteur mural.
- Le sens d'installation doit se rapporter à la Fig.2 lors de la fixation murale.
- Une maintenance périodique doit être réalisée tous les 2 à 3 mois, car des filtres obstrués peuvent entraîner de la condensation dans l'unité à cause de la réduction du flux d'air.
- Veillez porter des gants pour éviter de vous pincer les doigts pendant la maintenance.
- Veillez faire attention à la poussière, à la condensation ou aux pièces qui pourraient tomber lorsque vous ouvrez le couvercle.

PROCÉDURE DE MAINTENANCE

- Ouvrez le couvercle en déverrouillant les verrous. Si cela n'est pas pratique pour la maintenance, vous pouvez également le couvrir. (Fig.3)
- Enlevez les filtres AA et AR pour les nettoyer avec un aspirateur. (Fig.4)
- Nettoyez le noyau de récupération avec un aspirateur. (Fig.5)
- Remplacez les filtres AA et AR. Assurez-vous que le sens de la flèche sur le filtre AA est correcte. (Fig.6)
- Reinstallez le couvercle puis verrouillez les verrous et fermez. (Fig.7)
- Branchez l'appareil, appuyez sur le bouton de réinitialisation, un bip "beep" se fait entendre. Le voyant du filtre et le son sont désactivés. (Fig.8)

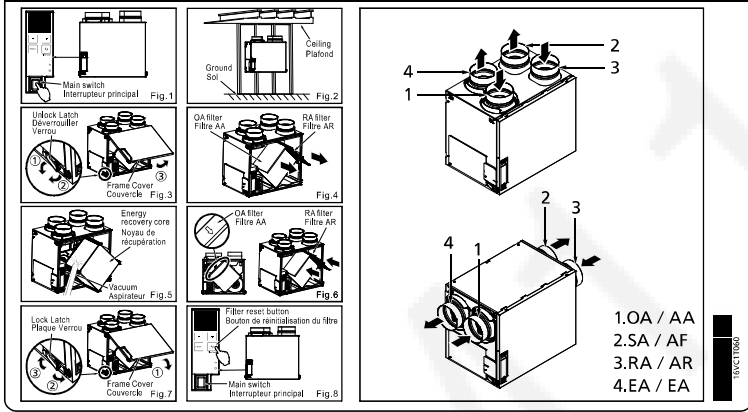

30

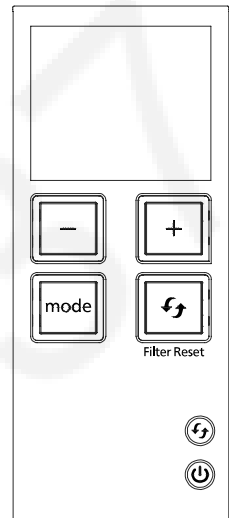

31



32

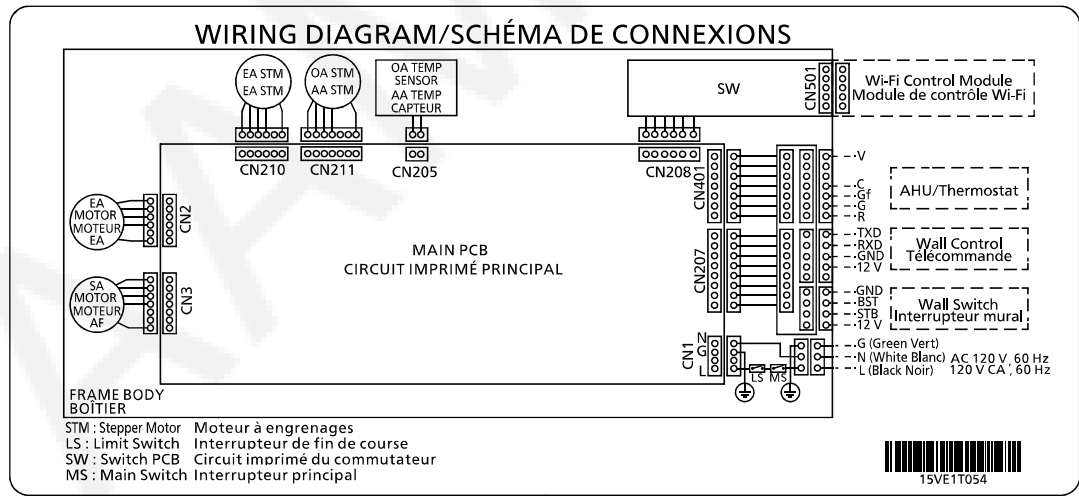

33

2. Parts Identification

FV-15VE1T

Packing Case Assy

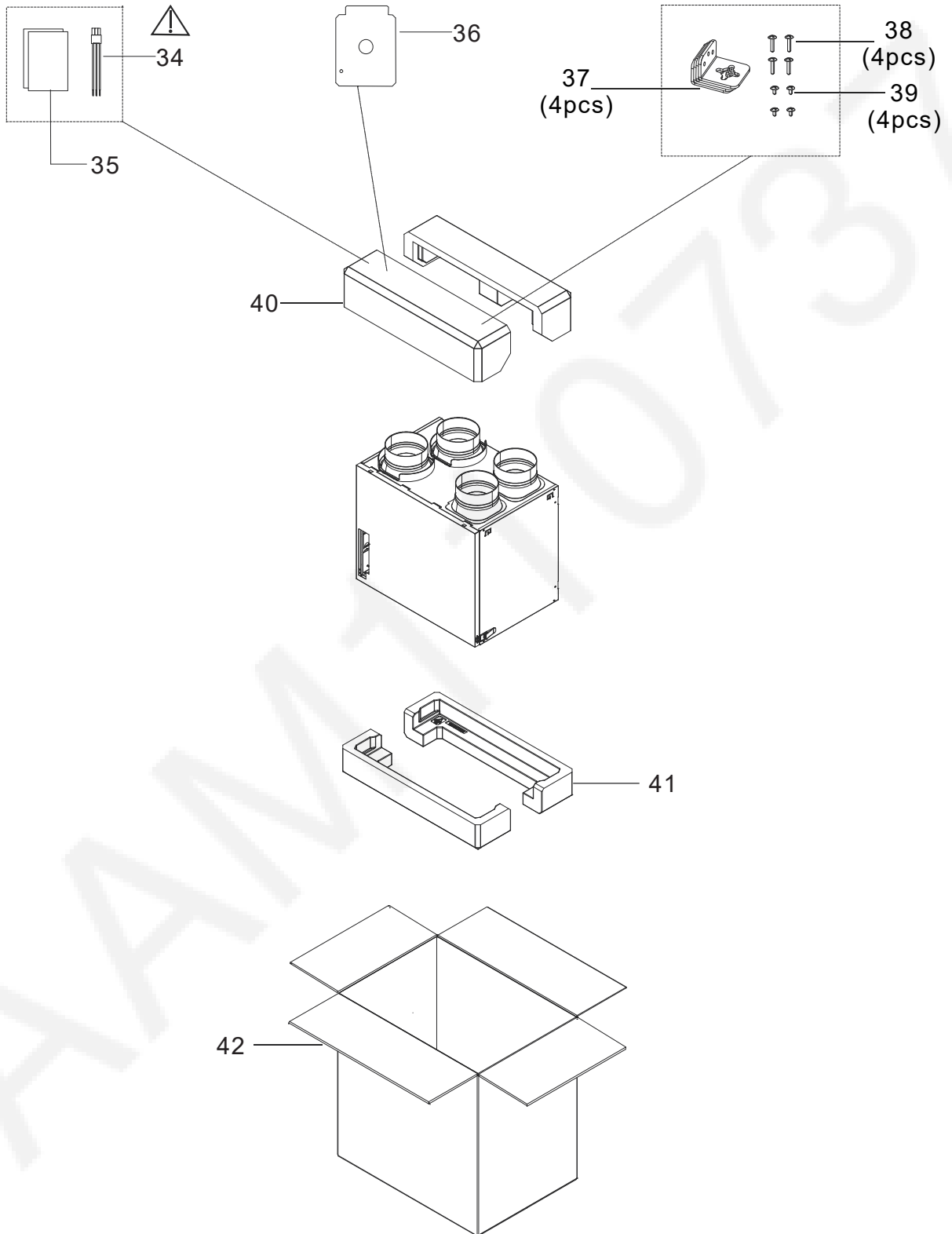

3. Wiring diagram



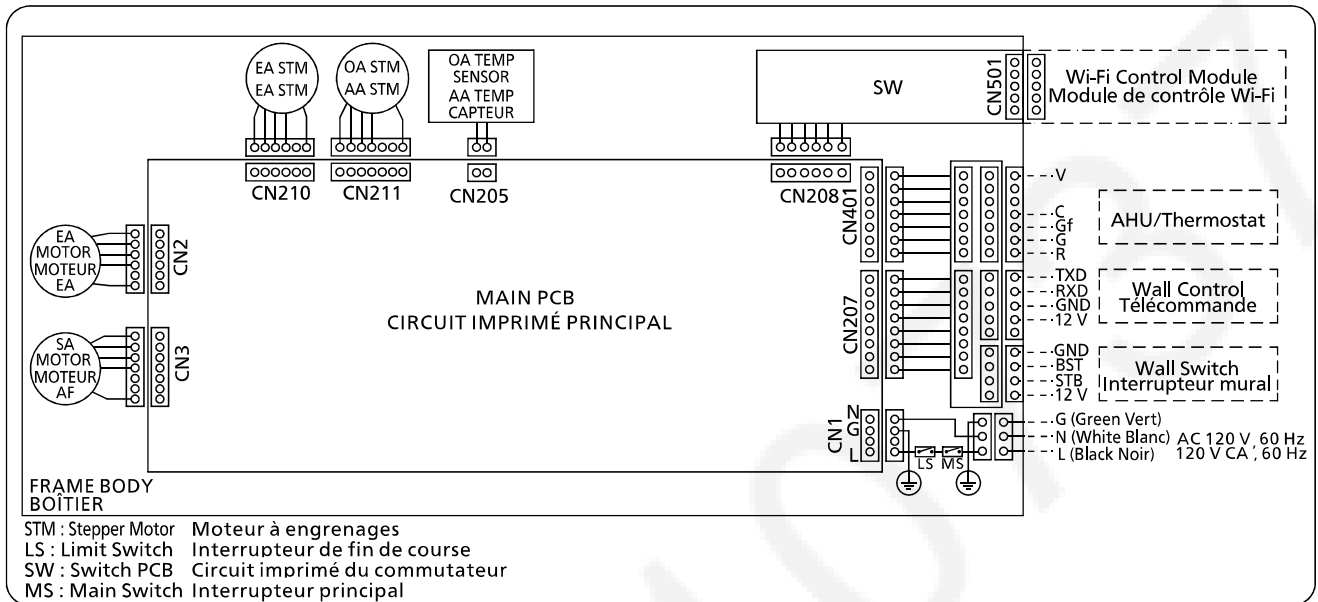



FV-15VE1T



4.Maintenance

FV-15VE1T

CAUTION

-  Electric shock may result. Disconnect power by switching off main switch, then unplug before working on the unit. If a standby switch is connected, it is recommended to switch it off first.
-  Routine maintenance must be performed every 2 or 3 months. clogged filters may cause condensation on the unit due to air flow reduction.
-  Please wear gloves to avoid pinching fingers during maintenance.
-  Please pay attention to dust, condensation water, or parts that may drop down when the door is opened.
-  Never use gasoline, benzene, thinner or any other such chemicals to clean the ERV.
-  Do not allow water to enter ERV.
-  Do not immerse resin parts in water over 60 °C.

- 1** Open the door by unlocking the latches.

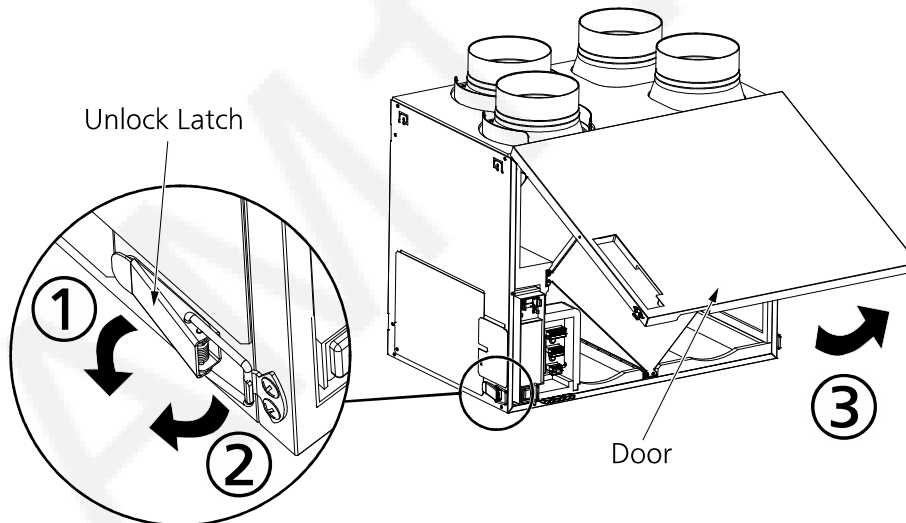

4. Maintenance

FV-15VE1T

2 Clean the OA filter, RA filter and energy recovery core.

It is suggested to replace the OA filter every 6 months. Please fill in beginning time on new OA filter before replacing.

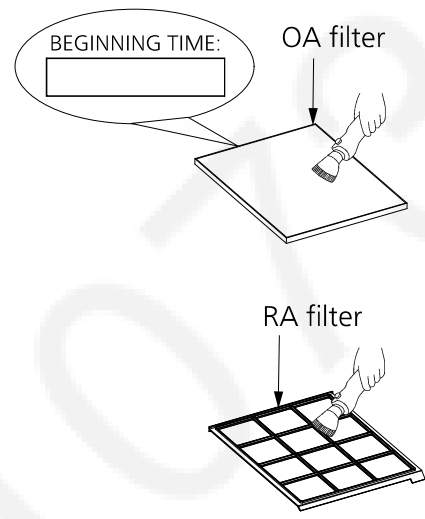
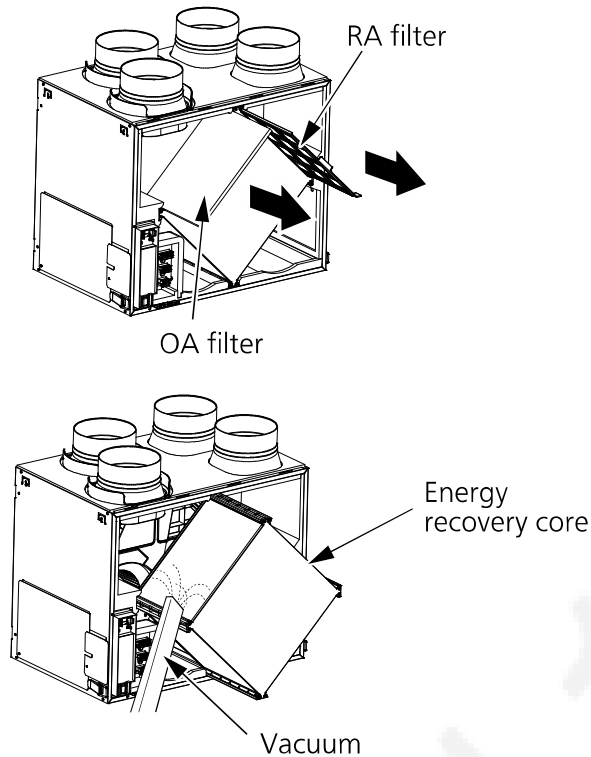

3 Reinstall the filters.

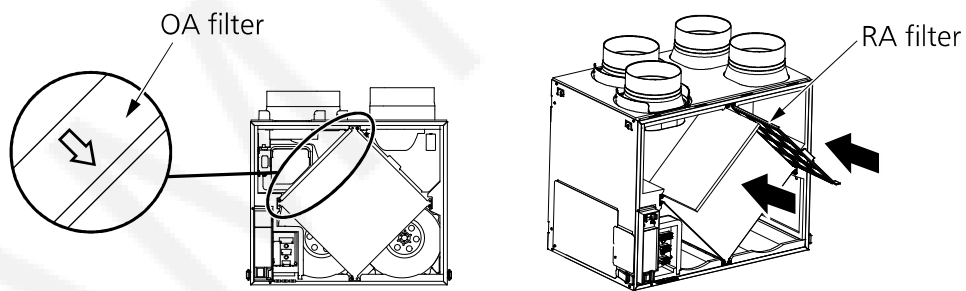

4 Reinstall and close door by locking the latches.

5 Connect power and press filter reset button. When the unit beeps, the filter reset timer will be reset.

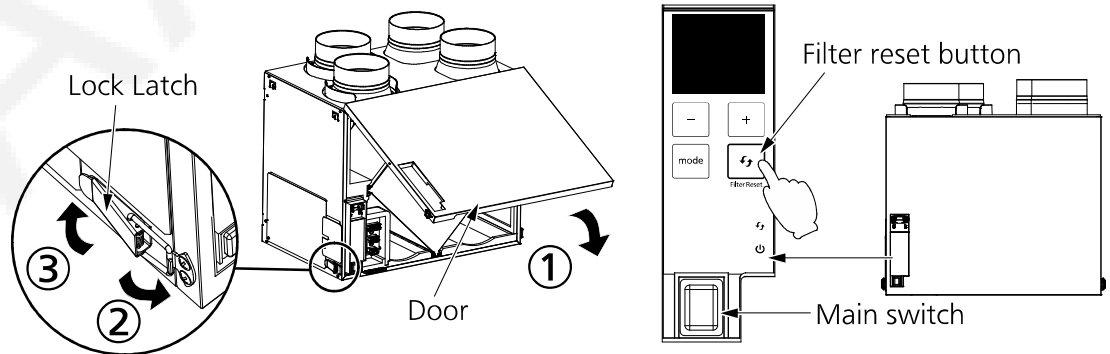

5. Troubleshooting

FV-15VE1T

If a problem is encountered, please investigate it by going through the following items.
If the problem still persists, please disconnect the power and contact the dealer for repair.

Problem	Display	Running indicator (Green)	Filter indicator (Orange)	Action
1.The ERV doesn't work.	-	Off	Off	<ul style="list-style-type: none"> ■ Check the power is connected. ■ Check the door is closed. ■ Check that the main switch on the product is on. ■ Check if the spring on the inside of the door is damaged or deformed.
		On	Off	<ul style="list-style-type: none"> ■ ERV running interval according to the ASHRAE time setting. ■ When outdoor temperature is very low ERV stops operating automatically.(see P.4) ■ Damper may be frozen shut, please wait for maximum 24 hours for defrosting.
2.The HVAC/AHU doesn't work when ERV works.	-	On	Off	<ul style="list-style-type: none"> ■ Check the wiring connection. (P.6-7)
3.Alarm sounds (10 sec every hour) and ERV works.	-	On	On	<ul style="list-style-type: none"> ■ The RA filter and OA filter need to be maintained. If you do not want the buzzer notification, see configuration setting (p.16-17).
4.Alarm sounds (30 sec every hour) and ERV doesn't work.	F03	Blink	Off	<ul style="list-style-type: none"> ■ PCB error, please disconnect the power and contact the dealer for repair.
	F10	Blink	Off	<ul style="list-style-type: none"> ■ OA temperature sensor error, please disconnect the power and contact the dealer for repair.
	F20	Off	Off	<ul style="list-style-type: none"> ■ SA motor error, please disconnect the power and contact the dealer for repair.
	F21	Off	Off	<ul style="list-style-type: none"> ■ EA motor error, please disconnect the power and contact the dealer for repair.
	F30	Off	Off	<ul style="list-style-type: none"> ■ Damper error, please disconnect the power and contact the dealer for repair.
	F60	Blink	Off	<ul style="list-style-type: none"> ■ Supply air flow is significantly decreasing. Check the ducting and the filter.
	F61	Blink	Off	<ul style="list-style-type: none"> ■ Exhaust air flow is significantly decreasing. Check the ducting and the filter.
5.Alarm sounds (30 sec every hour) and ERV works.	F01	Blink	Off	<ul style="list-style-type: none"> ■ Wall control communication error. Check the wall control wiring.(P.6-7)
	F04	Blink	Off	<ul style="list-style-type: none"> ■ PCB communication error. Contact the dealer for repair. *
	F11	Blink	Off	<ul style="list-style-type: none"> ■ OA humidity sensor error. Contact the dealer for repair. *
	F12	Blink	Off	<ul style="list-style-type: none"> ■ RA temperature sensor error. Contact the dealer for repair. *
	F13	Blink	Off	<ul style="list-style-type: none"> ■ RA humidity sensor error. Contact the dealer for repair. *
	F60	Blink	Off	<ul style="list-style-type: none"> ■ Supply air flow is decreasing. Check the ducting and the filter.
	F61	Blink	Off	<ul style="list-style-type: none"> ■ Exhaust air flow is decreasing. Check the ducting and the filter.

*Some functions will be limited when this error is encountered.

5. Troubleshooting

FV-15VE1T

Problem	Display	Running indicator (Green)	Filter indicator (Orange)	Action
6. ERV behaves differently from the selected air flow settings.	-	Blink	Off	<ul style="list-style-type: none">■ When product runs in recirculation mode for frost prevention, the air volume will be more than setting and sound will be slightly louder than normal operation.■ When outdoor temperature is less than 14 °F (-10 °C), the product will restrict air volume automatically to protect energy recovery core.

6. Parts List

FFV-15VE1T

Main Body Section

No.	Part No.	Part Name	Q'ty	Remark
1	FFV16VC1T204	Power Cord	1	⚠
2	FFV0720012S	Cord Bushing	1	
3	FFV16VC1T954	Wiring Cover P	1	
4	FFV16VC1T951	Main PCB Cover	1	
5	FFV16VC1T911	Adapter Cover	2	
6	FFV16VC1T917	Adapter	2	
7	FFV16VC1T901	Main Frame	1	
8	FFV16VC1T120	EA Fan Assy	1	⚠
9	FFV16VC1T110	SA Fan Assy	1	⚠
10	FFV15VE1T530	Damper OA Assy	1	
11	FFV16VC1T530	Damper OA Assy	1	⚠
12	FFV15VE1T561	Separator R Assy	1	
13	FFV15VE1T551	Separator L Assy	1	⚠
14	FFV16VC1T510	PCB Case Assy	1	⚠
15	FFV2800028S	Jumper Cable	1	⚠
16	FFV15VE1T801	OA Filter M13	1	
17	FFV16VC1T811	RA Filter	1	
18	FFV15VE1T990	Element Comp Unit	1	
19	FFV16VC1T934	Frame Cover assy	1	
A	FFVXTT4+8FFJ	Truss Taptite S	1	
B	FFVXTT412GFJ	Truss Taptite P	12	

Frame Body Assy

No.	Part No.	Part Name	Q'ty	Remark
20	FFV10VC2R323	Latch Base	1	
A	FFVXTT4+8FFJ	Truss Taptite S	4	

6. Parts List

FV-15VE1T

SA Fan Assy/EA Fan Assy

No.	Part No.	Part Name	Q'ty	Remark
21	FFV16VC1T921	Casing	2	
22	FFV10VC2M920	Flange Nut	2	
23	FFV10VC2R9	Fan fix Plate	2	
24	FFV16VC1T925	Fan	2	
25	FFV16VC1T92	Motor Base	2	
26	FFV16VC1TM21C	SA Motor Assembly	1	⚠
27	FFV16VC1TM23C	EA Motor Assembly	1	⚠
28	FFV16VC1T924	Motor Holder	2	
B	FFVXTT412GFJ	Truss Taptite P	7	

Frame Cover Assy

No.	Part No.	Part Name	Q'ty	Remark
29	FFV3440021S	Latch	2	
A	FFVXTT4-8FFJ	Truss Taptite S	2	

Main Labels

No.	Part No.	Part Name	Q'ty	Remark
30	FFV16VC1T060	Maintenance Label	1	
31	FFV16VC1T053	Switch Label	1	
32	FFV51VHL1053	HVI Mark	1	
33	FFV16VC1T054	Wiring Label	1	

Packing Case Assy

No.	Part No.	Part Name	Q'ty	Remark
34	FFV16VCT205	Power Cord H	1	⚠
35	FFV16VC1T450	Installation Inst US	1	
36	FFV16VC1T955	Wiring Cover H	1	
37	FFVXTT4-8FFJ	Truss Taptites S	4	
38	FFVXTT430AFJ	Truss Tap Screw	4	
39	FFV16VC1T970	L Plate	1	
40	FFV16VC1T401	Packing Pad Top	1	
41	FFV16VC1S402	Packing Pad Bottom	1	
42	FFV15VE1T420	Packing Case Assy	1	