

SUPPLEMENTARY INSTALLATION INSTRUCTIONS

Ventilating Fan (Contractor Pack)

Model No. **FV-05-10VSA3**

Contents

General Safety Information	2-3
Description	4
Unpacking	4
Supplied Accessories (4 sets)	4
Wiring Diagram	4
Installation I (Joist Mounting)	5-6
Installation II (Wall Mounting)	7
Maintenance (Cleaning)	Back cover
Product Service	Back cover

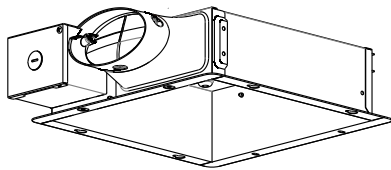

Housing Can
FV-05-10VSA3

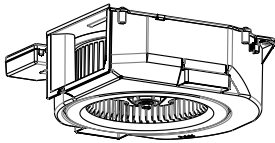

Motor / Grille Assembly:
FV-05VSB3, FV-08VSB3, FV-10VSB3E

Applicable to Model:

FV-05VS3, FV-08VS3, FV-10VS3E

READ AND SAVE THESE INSTRUCTIONS

Thank you for purchasing this Panasonic product.

Please read these instructions carefully before attempting to install, operate or service the Panasonic product. Failure to comply with instructions could result in personal injury or property damage. Please explain to users how to operate and maintain the product after installation, and this booklet should be presented to users.

Please retain this booklet for future reference.

GENERAL SAFETY INFORMATION

For Your Safety

To reduce the risk of injury, loss of life, electric shock, fire, malfunction, and damage to equipment or property always observe the following safety precautions.

Explanation of symbol word panels

The following symbol word panels are used to classify and describe the level of hazard, injury, and property damage caused when the denotation is disregarded and improper use is performed.



Denotes a potential hazard that could result in serious injury or death.











Denotes a hazard that could result in minor injury.

The following symbols are used to classify and describe the type of instructions to be observed.

	This symbol is used to alert users to a specific operating procedure that must not be performed.
	This symbol is used to alert users to a specific operating procedure that must be followed in order to operate the unit safely.
	This symbol is used to alert users not to disassemble the equipment.
	This symbol is used to alert users to make sure of grounding when using the equipment with the grounding terminal.











To reduce the risk of fire, electric shock or injury to persons, observe the following :

-  Use this unit only in the manner intended by the manufacturer. If you have any questions, contact the manufacturer.
-  Before servicing or cleaning unit, switch power off at service panel and lock the service disconnecting means to prevent power from being switch on accidentally. When the service disconnecting means cannot be locked, securely fasten a prominent warning device, such as a tag, to the service panel.
-  Installation work and electrical wiring must be done by qualified person(s) in accordance with all applicable codes and standards, including fire-rated construction.
-  Sufficient air is needed for proper combustion and exhausting of gases through the flue (chimney) of fuel burning equipment to prevent back drafting. Follow the heating equipment manufacturer's guideline and safety standards such as those published by the National Fire Protection Association (NFPA), and the American Society for Heating, Refrigeration and Air Conditioning Engineers (ASHRAE) and the local code authorities.
-  When cutting or drilling into wall or ceiling, do not damage electrical wiring and other hidden utilities.
-  Ducted fans must always be vented to the outdoors.
-  If this unit is to be installed over a tub or shower, it must be marked as appropriate for the application and be connected to a GFCI (Ground Fault Circuit Interrupter) - protected branch circuit.
-  These models are UL listed for tub and shower enclosures.

GENERAL SAFETY INFORMATION CONTINUED

WARNING

-  Canada only: Not to be installed in a ceiling thermally insulated to a value greater than R40.
-  Do not disassemble the unit for reconstruction. It may cause fire or electric shock.
-  A statement to the effect that when the product is to no longer be used, it must not be left in place but removed, to prevent it from possible falling.
-  Ceiling joist or wall stud must be subjected to static load more than five times the weight of the product.
-  Do not install with a method which is not approved in the instructions.
-  Do not use this fan with any solid-state speed control device. Solid state controls may cause harmonic distortion which can cause motor humming noise.
-  Install the fan at least 1.5m (5 feet) above the floor, and the fan must be installed above a counter or major appliances that serves as a barrier.
-  The Housing Can FV-05-10VSA3 must be installed with Motor / Grille Assembly FV-05VSB3, FV-08VSB3 or FV-10VSB3E that are marked on their Cartons to indicate the suitability with this model. Other Motor / Grille Assembly can not be substituted.
-  This product must be properly grounded.

CAUTION











-  Do not install this ventilating fan where interior room temperature may exceed 104°F (40°C).
-  Make sure that the electric service supply voltage is AC 120V, 60 Hz.
-  Follow all local electrical and safety codes, as well as the National Electrical Code (NEC) and the Occupation Safety and Health Act (OSHA).
-  Always disconnect the power source before working on or near the fan, motor, light fixture or junction box.
-  Protect the supply wiring from sharp edges, oil, grease, hot surfaces, chemicals or other objects.
-  Do not kink the supply wiring.
-  Provide make up air for proper ventilation.
-  For general ventilating use only. Do not use to exhaust hazardous or explosive materials and vapors.
-  Do not install the unit where ducts are configured as shown in Fig.A.
-  Not for use in cooking area. (Fig.B)
-  The special-purpose or dedicated parts, such as mounting fixtures, must be used if such parts are provided.



Fig. A

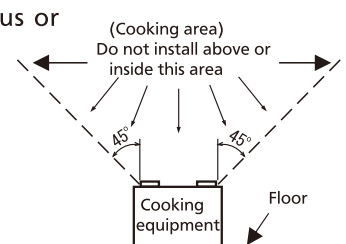

Fig. B

DESCRIPTION

These Panasonic ventilating fan models are listed by UL under UL file No. E78414.

These Panasonic ventilating fan models use a sirocco fan driven by a capacitor motor.

The motor is designed to have an extended service life with reduced energy consumption.

It also incorporates a thermal-cutoff for safety. The grille covering the fan body is a spring-loaded, quick remove type. A damper for preventing air counterflow is provided. The blower uses a high-capacity sirocco fan developed to reduce the noise level.



UNPACKING



Unpack and carefully remove the unit from carton.

Refer to the supplied accessories list to verify that all parts are present.

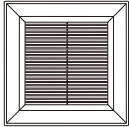

SUPPLIED ACCESSORIES(4 SETS)

(A) For Motor/Grille Assembly of model:
FV-05VSB3, FV-08VSB3, FV-10VSB3E

Part name	Appearance	Quantity
Grille		4
Screw I (ST4.2X12)		8
Screw II (ST4.2X6)		4

Part name	Appearance	Quantity
Installation instructions		2
Warranty sheet		1

(B) For Housing Can of model: FV-05-10VSA3

Part name	Appearance	Quantity
Long screw (ST4.2X30)		20
Installation instructions		2

WIRING DIAGRAM

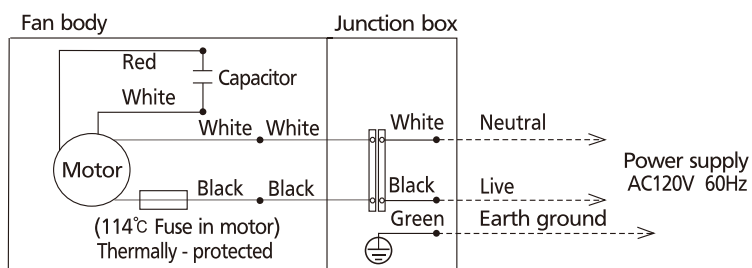

INSTALLATION I (JOIST MOUNTING)

1. Before installation, remove the tape from damper and adaptor, and check that the damper can open and close smoothly. (Fig.1)

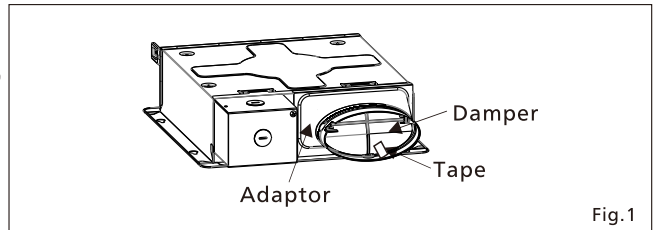

Fig.1

2. Fix the flange of frame to joist by 2 long screws (ST4.2X30), and fix the suspension bracket to joist by 2 long screws (ST4.2X30). (Fig.2)

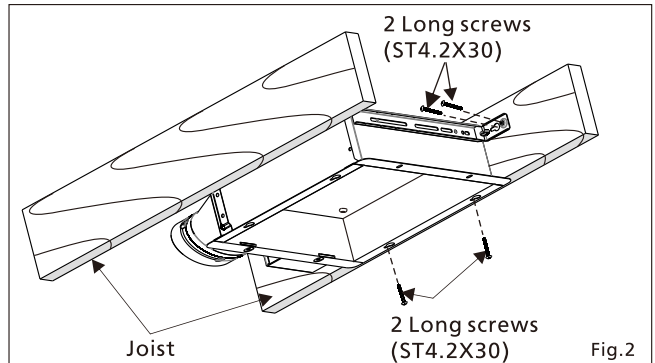

Fig.2

3. Remove junction box cover and secure conduit or stress relief to junction box knock-out hole. (Fig.3)

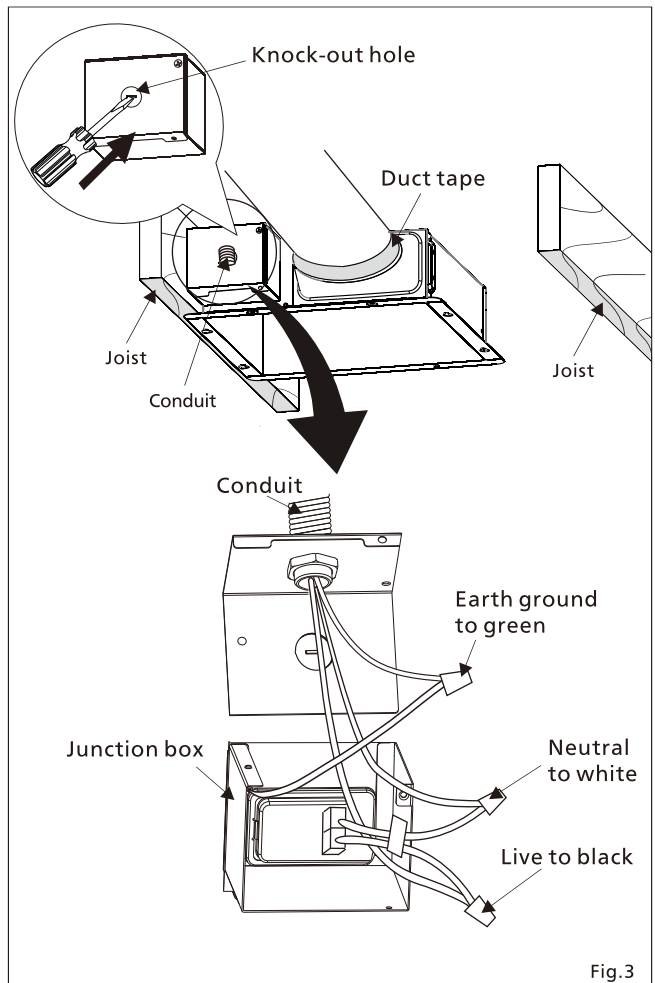

Fig.3

4. Refer to wiring diagram. Follow all the local electrical safety codes as well as the National Electrical Code (NEC). Using UL approved wire nuts, connect house power wires to ventilating fan wires.

CAUTION

Mount junction box cover carefully so that lead wires are not pinched.

Note:

For wiring details, please refer to the wiring diagram on page 4.

5. A 4 inch circular duct is needed to connect to the relevant part of adaptor. Squeeze the circular duct to fit the adaptor, then slip onto the adaptor and secure it with a clamp and seal it with approved duct tape or mastic. (If using 3 inch round duct, please purchase the 26 gauge steel Panasonic 4" Oval - 3" Round Reducer from our representative.) (Fig.3)

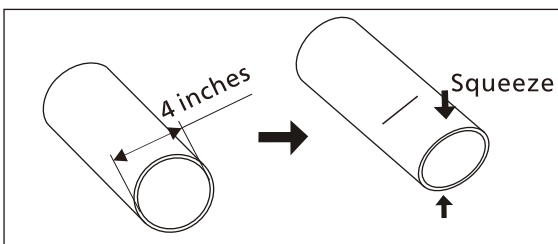

INSTALLATION I (JOIST MOUNTING) CONTINUED

6. Finish ceiling work. Ceiling hole should be aligned with the inside edge of the flange. (Fig.4)

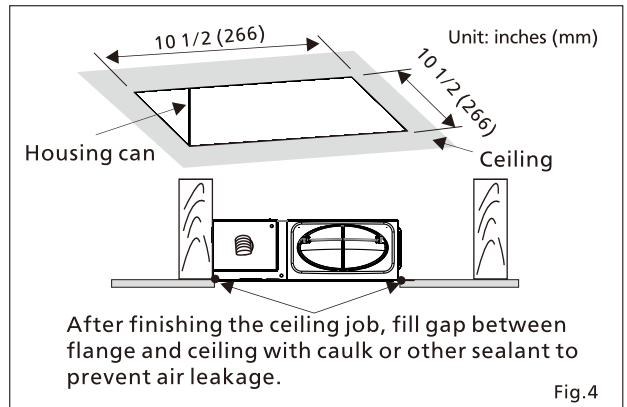

7. Insert the blower into the housing can. (Fig.5)

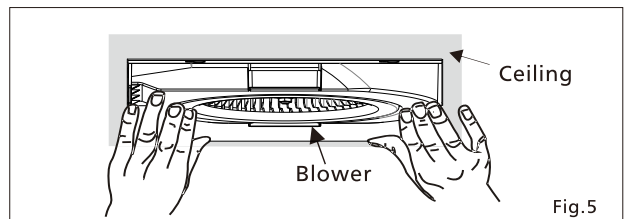

8. Secure the blower and plug connector to receptacle.(Fig.6)

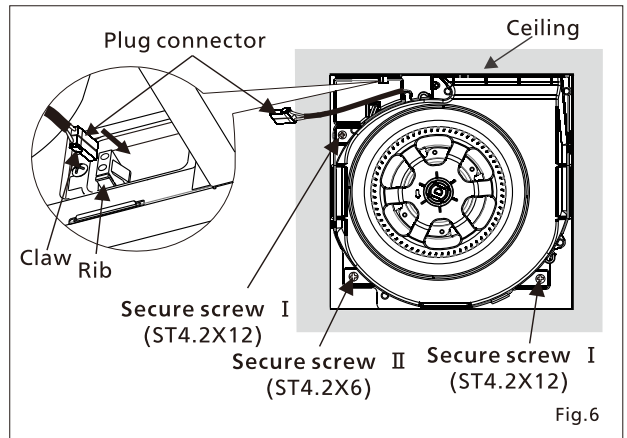

9. Remove the tape from mounting springs before installation.(Fig.7)

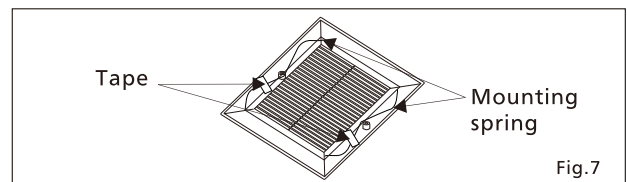

10. Insert the grille mounting springs into the slots and mount grille to fan body. (Fig.8)

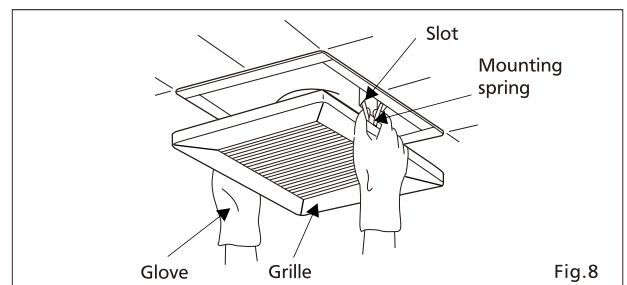

CAUTION

- ! Before turn on the fan, make sure the connector insert at the correct position. If not, the fan can't work.(Fig.6)
- ! The claw of connector must latch the rib completely.(Fig.6)

INSTALLATION II (WALL MOUNTING)

1. Before installation, remove the tape from damper and adaptor, and check that the damper can open and close smoothly. (Fig.1 of page 5)
2. Fix the flange of frame to stud by 2 long screws (ST4.2X30), and fix the suspension bracket to stud by 2 long screws (ST4.2X30). (Fig.9)

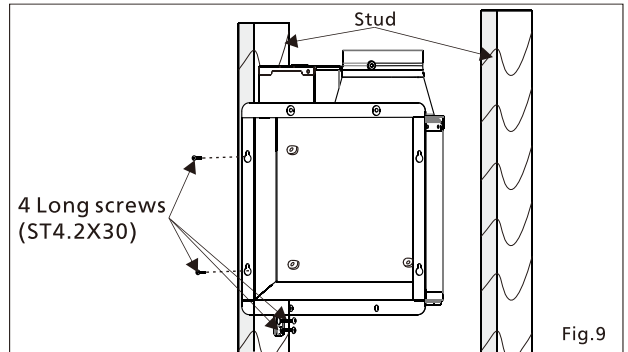

CAUTION

-  The adaptor of product must be installed upward. (Fig.9)

3. Complete the wiring and duct work (refer to step 3 to 5 of INSTALLATION I on page 5).
4. Finish the wall work. Wall hole should be aligned with the inside edge of the flange. (Fig.10)
5. Insert the blower into the housing can. (Fig.5 of page 6)
6. Secure the blower and plug connector to receptacle. (Fig.6 of page 6)
7. Install the grille (refer to step 9 to 10 of INSTALLATION I on page 6).

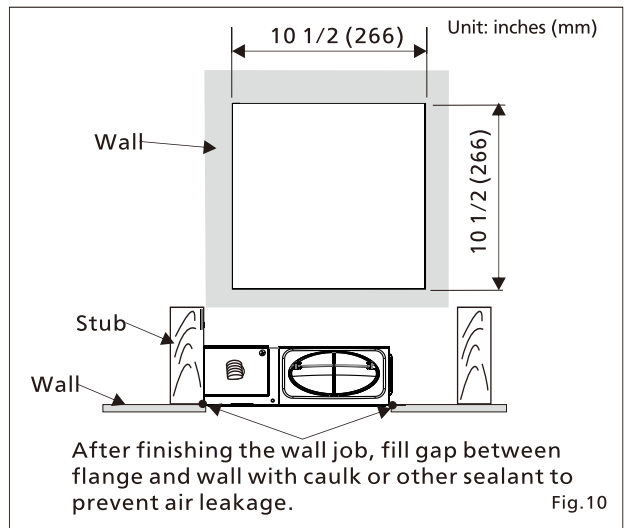



MAINTENANCE (CLEANING)

WARNING

 Disconnect power source before working on unit.

CAUTION

 Routine maintenance must be done every year.

 Never use gasoline, benzene, thinner or any other such chemicals for cleaning the ventilating fan.

 Do not immerse motor in water when cleaning.
Do not soak resin parts in water over 140°F (60°C).

1. Remove grille. (Squeeze mounting springs and pull down carefully.)(Fig.11)
2. Wash and clean grille.
(Use non-abrasive kitchen detergent, wipe dry with clean cloth.)(Fig.12)
3. Remove dust and dirt from fan body using a vacuum cleaner. (Fig.13)
4. Using a cloth dampened with kitchen detergent, remove any dirt from fan body. Wipe dry with clean cloth. (Fig.14)
5. Replace grille.

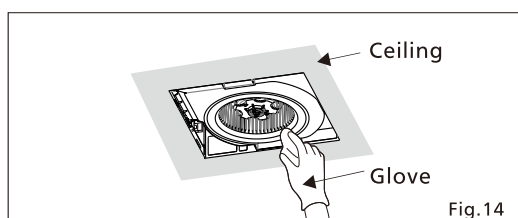
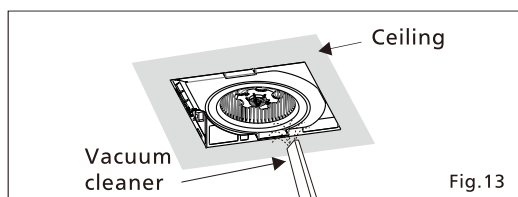
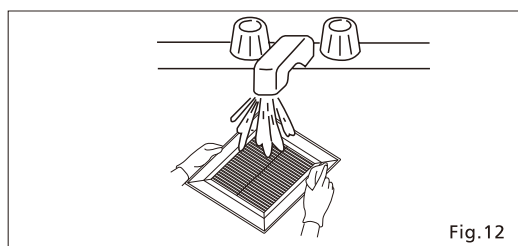
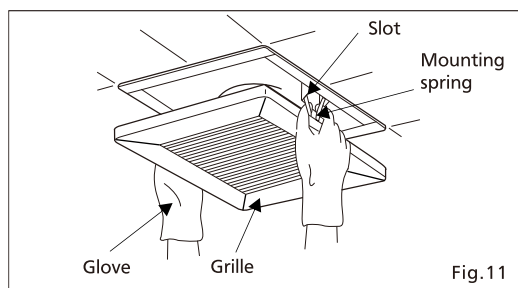

PRODUCT SERVICE

Warning Concerning Removal of Covers.

The unit should be serviced by qualified technicians only.

Your product is designed and manufactured to ensure a minimum of maintenance.

Should your unit require service or parts, call Panasonic Call Center at 1-866-292-7299 (USA) or 1-800-669-5165 (Canada).

Panasonic Corporation of North America

Two Riverfront Plaza, Newark, NJ 07102

www.panasonic.com

Panasonic Canada Inc.

5770 Ambler Drive, Mississauga, Ontario L4W 2T3

www.panasonic.ca

© Panasonic Corporation 2013 - 2015

Printed in China

T0613-20915 08VSA3420B