

Specification Submittal Data / Panasonic Ventilation Fan

Description:

Ventilating fan shall be Low Noise ceiling or wall mount type rated for continuous run. Fan shall be ENERGY STAR[®] rated and certified by the Home Ventilation Institute (HVI). Evaluated by Underwriters Laboratories and conform to both UL and cUL safety standards.

Motor/Blower:

- Enclosed brushless ECM motor technology rated for continuous run.
- Fan ventilation rates shall be manually adjustable for 80 or 100 CFM.
- Power rating shall be 120 volts and 60 Hz.
- Fan shall be UL and cUL listed for tub/shower enclosure when GFCI protected and used in insulated ceiling (TYPE I.C.).
- PCB board equipped with thermal-cut-off fuse.
- Removable with permanently lubricated plug-in motor.

Housing:

- 26 gauge galvanized steel body.
- Built-in 4" Oval duct collar. Also compatible with 4" round duct.
- Optional 24 gauge steel, fire code rated 4" oval to 3" round duct adaptor sold separately (Model # FV-VS43R).
- Built in backdraft damper.
- Built-in metal flange provides blocking for penetrations through drywall as an Air Barrier, and assists with the decrease in leakage in the Building Envelope during blower door testing.
- Unique L-shaped bracket simplifies installation and provides strong support.

Ceiling Radiation Damper:

- WhisperValue[®] DC is UL listed for use with the Panasonic Ceiling Radiation Damper (Model #: PC-RD05C5, sold separately).

Grille:

- Attractive design using Poly Pro material.
- Attaches directly to housing with torsion springs.

Warranty:

- ECM Motor: 6 Years from original purchase date.
- ALL Parts: 3 Years from original purchase date.

Architectural Specifications:

Ventilation fan shall be UL and cUL listed for ceiling or wall mount and tub/shower enclosure when GFCI protected. Fan shall also be ENERGY STAR[®] certified with multispeed control (0, 30-70 CFM, in 10 CFM increments) that shall be built-in and activated by a wall switch. Fan shall also incorporate a built-in speed selector. Choose from 80 or 100 CFM and no more than 0.4/0.9 sone as certified by the Home Ventilating Institute (HVI) at 0.1 static pressure in inches water gauge (w.g.) with no less than 81/101 CFM and no more than 0.8/1.3 sone as certified by HVI at 0.25 w.g., and no less than 75/83 CFM at 0.375 w.g. Power Consumption shall be no greater than 8.5/12.4 watts at 0.1 w.g. and 13.2/18.0 watts at 0.25 w.g., and 16.0/18.0 watts at 0.375 w.g. with efficiency of no less than 10.0/8.2 CFM/watt at 0.1 w.g. and 6.5/5.7 CFM/watt at 0.25 w.g., and 4.7/4.6 CFM/watt at 0.375 w.g. The motor shall be totally enclosed with a brushless ECM motor engineered to run continuously. ECM motor speed shall automatically increase when the fan senses static pressure to maintain selected CFM. Power rating shall be 120V/60Hz. Duct diameter shall be no less than 4". Optional 24 gauge steel, fire code rated 4" oval to 3" round duct adaptor sold separately (Model FV-VS43R). Fan can be used to comply with ASHRAE 62.2, LEED, EarthCraft, California Title-24 and WA Ventilation Code.

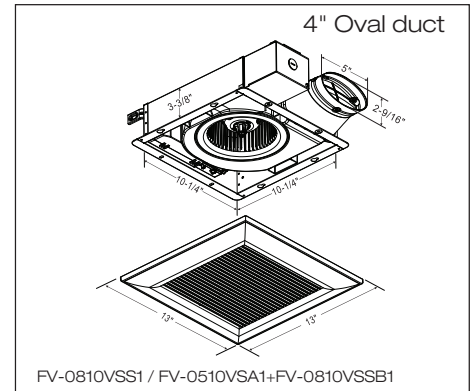

Performance Curve 4" Oval duct

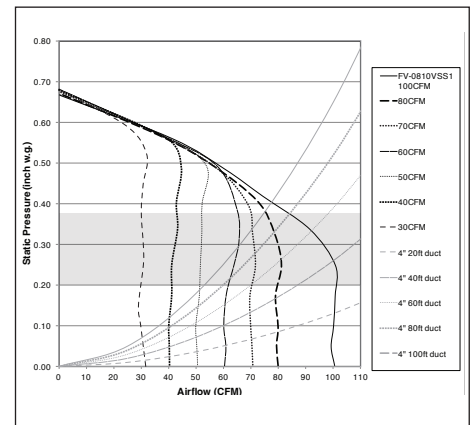

Specifications and Additional Features on following page.

Specification Submittal Data / Panasonic Ventilation Fan
(Continued)



ECM Motor Technology

When the fan senses static pressure, its speed is automatically increased to ensure that the desired CFM is not compromised, which allows the fan to perform as rated.

Multi-Speed for ASHRAE 62.2 Compliance

Select the proper CFM settings to satisfy ASHRAE 62.2 continuous ventilation requirements. The fan runs continuously at a preset lower level (0, 30-70, in 10 CFM increments), then elevates to a maximum level of operation (80 or 100 CFM) when the wall switch is turned on.

Fan Specifications		WhisperValue [®] : FV-0810VSS1 / FV-0510VSA1+FV-0810VSSB1																				
Fan Setting		4" Oval			4" Oval			4" Oval			4" Oval			4" Oval			4" Oval			4" Oval		
Ventilation Fan Characteristics (HVI Certified Data)	Static Pressure in inches w.g.	0.1	0.25	0.375	0.1	0.25	0.375	0.1	0.25	0.375	0.1	0.25	0.375	0.1	0.25	0.375	0.1	0.25	0.375	0.1	0.25	0.375
	Air Volume (CFM)	100	101	83	80	81	75	70	72	70	60	64	65	50	52	52	40	41	42	30	31	30
	Noise (sones)	0.9	1.3	-	0.4	0.8	-	<0.3	0.6	-	<0.3	0.6	-	<0.3	0.5	-	<0.3	0.5	-	<0.3	0.5	-
	Power Consumption (watts)	13.4	18.5	18.0	8.5	13.2	16.0	6.5	10.8	15.0	5.3	9.3	13.0	4.5	7.7	12.0	3.8	6.7	10.0	3.4	6.0	9.0
	Energy Efficiency (CFM/Watt)	7.5	5.5	4.6	10.0	6.5	4.7	11.2	6.9	4.7	11.8	7.2	5.0	12.1	7.3	4.3	11.8	6.9	4.2	10.2	6.0	3.3
	Speed (RPM)	970	1197	1300	856	1114	1270	805	1088	1260	770	1076	1250	733	1050	1230	723	1037	1215	711	1033	1200
	Current (amps)	0.22	0.29	0.25	0.13	0.20	0.24	0.10	0.16	0.22	0.09	0.15	0.20	0.08	0.13	0.17	0.07	0.11	0.15	0.06	0.10	0.13
	MAX. Current (amps)	0.39																				
	Power Rating (V/Hz)	120/60																				
	ENERGY STAR rated	YES																				

*Industry research indicates static pressure in typical installations ranges from 0.20" to 0.375"

WhisperValue[®] is Offered in Two Convenient Packs:

Single pack: Housing and motor/grille assembly are packaged together. This easy-to-manage package design allows contractors the convenience of having multiple components assembled in one box.

Contractor pack: Housing and motor/grille assembly are packaged separately. This easy-to-manage package design allows contractors to store the components separately without fear of parts getting lost or damaged on site.

WhisperValue[®] Single Package

Model #	Description	Contents	Master pack
FV-0810VSS1	WhisperValue [®] DC Fan with Multi-Speed & Pick-A-Flow, 80/110 CFM	Housing, Duct Adapter, Junction Box, Motor & Grille	1

Optional WhisperValue[®] Universal Housing Contractor Packs

Model #	Description	Contents	Master pack*
FV-0510VSA1	Universal Housing	Housing, Duct Adapter & Junction Box	4
FV-0810VSSB1	Fan Motor & Grille Assembly with Multi-Speed Sensor	Motor, Grille & Multi-Speed Sensor	4

*Must order in quantities of 4, shipment will contain 1 box with 4 pieces of each items.

For complete Installation Instructions visit iaq.na.panasonic.com

Model	Quantity	Comments	Project:
			Location:
			Architect:
			Engineer:
			Contractor:
			Submitted by:
			Date:

Panasonic
IAQ Division
Two Riverfront Plaza
Newark, NJ 07102
iaq.na.panasonic.com

