

INSTALLATION, OPERATING AND SERVICE INSTRUCTIONS

AP-U™ SERIES

STEEL OIL-FIRED BOILER



For service or repairs to boiler, call your heating contractor. When seeking information on boiler, provide Boiler Model Number and Serial Number as shown on Rating Label.

Boiler Model Number AP- U	Boiler Serial Number	Installation Date
Heating Contractor		Phone Number
Address		



New Yorker®
RESIDENTIAL HEATING BOILERS

IMPORTANT INFORMATION - READ CAREFULLY

All boilers must be installed in accordance with National, State and Local Plumbing, Heating and Electrical Codes and the regulations of the serving utilities. These Codes and Regulations may differ from this instruction manual. Authorities having jurisdiction should be consulted before installations are made.

In all cases, reference should be made to the following Standards:

USA BOILERS

- A. Current Edition of American National Standard ANSI/NFPA 31, “Installation of Oil Burning Equipment”, for recommended installation practices.
- B. Current Edition of American National Standard ANSI/NFPA 211, “Chimneys, Fireplaces, Vents, and Solid Fuel Burning Appliances”, For Venting requirements.
- C. Current Edition of American Society of Mechanical Engineers ASME CSD-1, “Controls and Safety Devices for Automatically Fired Boilers”, for assembly and operations of controls and safety devices.
- D. All wiring on boilers installed in the USA shall be made in accordance with the National Electrical Code and/or Local Regulations.

The following terms are used throughout this manual to bring attention to the presence of hazards of various risk levels, or to important information concerning product life.

DANGER

Indicates an imminently hazardous situation which, if not avoided, will result in death, serious injury or substantial property damage.

CAUTION

Indicates a potentially hazardous situation which, if not avoided, may result in moderate or minor injury or property damage.

WARNING

Indicates a potentially hazardous situation which, if not avoided, could result in death, serious injury or substantial property damage.

NOTICE

Indicates special instructions on installation, operation, or maintenance which are important but not related to personal injury hazards.

NOTICE

This boiler has a limited warranty, a copy of which is printed on the back of this manual. The warranty for this boiler is valid only if the boiler has been installed, maintained and operated in accordance with these instructions.

DANGER

DO NOT store or use gasoline or other flammable vapors or liquids in the vicinity of this or any other appliance.

WARNING

Improper installation, adjustment, alteration, service or maintenance can cause property damage, personal injury or loss of life. Failure to follow all instructions in the proper order can cause personal injury or death. Read and understand all instructions, including all those contained in component manufacturers manuals which are provided with the boiler before installing, starting-up, operating, maintaining or servicing this boiler. Keep this manual and literature in legible condition and posted near boiler for reference by owner and service technician.

This boiler requires regular maintenance and service to operate safely. Follow the instructions contained in this manual.

Installation, maintenance, and service must be performed only by an experienced, skilled and knowledgeable installer or service agency.

All heating systems should be designed by competent contractors and only persons knowledgeable in the layout and installation of hydronic heating systems should attempt installation of any boiler.

Installation is NOT complete unless a pressure relief valve is installed into the tapping located on top of Shell Assembly in the front left corner - See Water Piping and Trim Section of this manual for additional details.

It is the responsibility of the installing contractor to see that all controls are correctly installed and are operating properly when installation is complete including verifying that the limit sensor is fully installed (seated in bottom of Well).

Failure to properly install Limit Sensor may result in property damage, personal injury or loss of life due to elevated operating temperatures and/or pressures.

This boiler is NOT suitable for installation on combustible flooring. **DO NOT** operate boiler on combustible flooring without factory supplied floor shield (available option at extra cost). A concrete pad is NOT sufficient to protect combustible flooring. Concrete over wood joists is considered combustible flooring.

DO NOT install boiler on carpeting.

When boiler is installed on concrete which is over a material that is subject to melting (PVC, PEX radiant tubing, etc.) a combustible floor shield must be used.

DO NOT operate on masonry floors, which may contain moisture.

DO NOT tamper with or alter the boiler or controls.

Retain your contractor or a competent serviceman to assure that the unit is properly adjusted and maintained.

Have Firetubes cleaned at least once a year - preferably at the start of the heating season to remove soot and scale. The inside of combustion chamber should also be cleaned and inspected at the same time.

When cleaning this boiler, **DO NOT** damage combustion chamber. If damaged, combustion chamber must be replaced immediately.

Oil Burner and Controls must be checked at least once a year or as may be necessitated.

DO NOT operate boiler with jumpered or absent controls or safety devices.

DO NOT operate boiler if any control, switch, component, or device has been subject to water.

Boiler materials of construction, products of combustion and the fuel contain alumina, silica, heavy metals, carbon monoxide, nitrogen oxides, aldehydes and/or other toxic or harmful substances which can cause death or serious injury and which are known to the state of California to cause cancer, birth defects and other reproductive harm. Always use proper safety clothing, respirators and equipment when servicing or working nearby the boiler.

WARNING

This boiler contains very hot water under 12 - 15 PSI pressure. **DO NOT** unscrew any pipe fittings nor attempt to disconnect any components of this boiler without positively assuring the water is cool and has no pressure. Always wear protective clothing and equipment when installing, starting up or servicing this boiler to prevent scald injuries. **DO NOT** rely on the pressure and temperature gauges to determine the temperature and pressure of the boiler. This boiler contains components which become very hot when the boiler is operating. **DO NOT** touch any components unless they are cool.

High water temperatures increase the risk of scalding injury. If this boiler is equipped with a tankless heater for domestic water supply, a flow regulator and automatic mixing valve must be installed properly in tankless heater piping. See Water Piping and Trim Section of this manual for details.

This boiler needs fresh air for safe operation and must be installed so there are provisions for adequate combustion and ventilation air.

This boiler must be connected to an approved chimney or vent system in good condition. Serious property damage could result if the boiler is connected to a dirty or inadequate chimney or vent system. The interior of the chimney flue must be inspected and cleaned before the start of the heating season for any obstructions. A clean and unobstructed chimney flue is necessary to allow noxious fumes that could cause injury or loss of life to vent safely and will contribute toward maintaining the boiler's efficiency. **DO NOT** operate boiler with the absence of an approved vent system.

This boiler is supplied with controls which may cause the boiler to shut down and not re-start without service. If damage due to frozen pipes is a possibility, the heating system should not be left unattended in cold weather; or appropriate safeguards and alarms should be installed on the heating system to prevent damage if the boiler is inoperative.

This boiler is designed to burn No. 2 fuel oil only. **DO NOT** use gasoline, crankcase drainings, or any oil containing gasoline. Never burn garbage or paper in this boiler. **DO NOT** convert to any solid fuel (i.e. wood, coal). **DO NOT** convert to any gaseous fuel (i.e. natural gas, LP). All flammable debris, rags, paper, wood scraps, etc., should be kept clear of the boiler at all times. Keep the boiler area clean and free of fire hazards.

TABLE OF CONTENTS

I. General Information.....	5	IX. Maintenance & Service Instructions.....	36
II. Pre-Installation.....	7	X. Boiler Cleaning	38
III. Water Piping and Trim	10	XI. Troubleshooting	40
IV. Venting	15	XII. Repair Parts	44
V. Electrical.....	17	XIII. Beckett AFG Burner Parts for AP-U™ Series Boilers	48
VI. Oil Piping.....	21	XIV. Riello Burner Parts for AP-U™ Series Boilers	50
VII. System Start-Up.....	23	Appendix A - Low Water Cut Off.....	51
VIII. Operating	31		

I: GENERAL INFORMATION

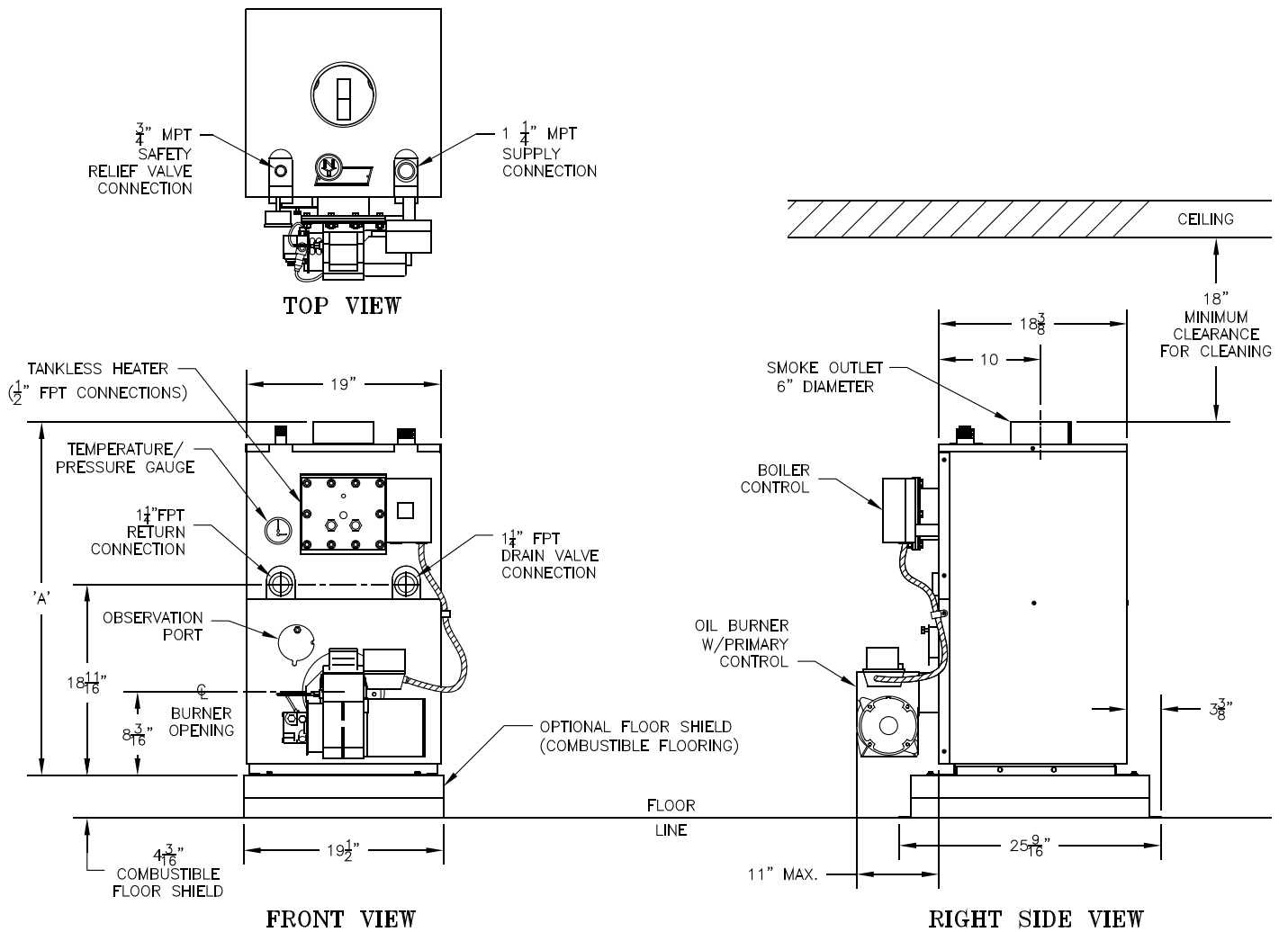

- NOTES:
1. CIRCULATOR SUPPLIED LOOSE – MAY BE INSTALLED ON SUPPLY (RECOMMENDED) OR RETURN (ACCEPTABLE ALTERNATIVE) PIPING.
 2. RETURN FITTINGS AND DRAIN VALVE SHIPPED LOOSE.

Figure 1: AP-U Series Boiler Dimensional Data

TABLE 1: DIMENSIONAL DATA (See Figure 1)

Boiler Model Number	Dimension 'A'	Water Capacity (gallons)	Approx. Shipping Weight (lb.)
AP-490U	34-9/16	10.7	290
AP-590U		10.1	300
AP-690U	41"	16.3	340
AP-790U		15.4	355

Note: Maximum Working Pressure: Water 30 PSI shipped standard.

I: GENERAL INFORMATION (continued)

TABLE 2: RATING DATA

Boiler Model No.	Burner Capacity		DOE Heating Capacity - MBH	AHRI NET Ratings - MBH	Minimum Chimney Requirements			AFUE %
	GPH	MBH			Round In. Dia.	Rectangle In. x In.	Height Ft.	
AP-490U	0.75	105	88	77	6	8 x 8	15	84
AP-590U	1.00	140	119	103	6	8 x 8	15	84
AP-690U	1.10	154	131	114	6	8 x 8	15	84
AP-790U	1.35	189	160	139	7	8 x 8	15	84

Boiler Model Suffix: P = Packaged

II: PRE-INSTALLATION

- A. INSPECT SHIPMENT** carefully for any signs of damage.
- All equipment is carefully manufactured, inspected and packed. Our responsibility ceases upon delivery of crated boiler to the carrier in good condition.
 - Any claims for damage or shortage in shipment must be filed immediately against the carrier by the consignee. No claims for variances from, or shortage in orders, will be allowed by the manufacturer unless presented within sixty (60) days after receipt of goods.
- B. LOCATE BOILER** near final position before removing crate. See Figure 1. Using hand truck or pipe rollers under skid, move boiler into position along side installation site.

CAUTION

DO NOT drop boiler. DO NOT bump boiler jacket against floor.

- LOCATE so that vent pipe connection to chimney will be short and direct.
- BOILER IS **NOT** SUITABLE FOR INSTALLATION ON COMBUSTIBLE FLOOR without factory supplied floor shield (available option at extra cost), see Page 9 for additional details. A Combustible Floor Shield can also be

constructed in accordance with NFPA 31. **DO NOT** install boiler on carpeting.

- FOR BASEMENT INSTALLATION, provide a solid elevated base, such as concrete, if floor is not level, or if water may be encountered on floor around boiler.

WARNING

DO NOT support boiler by placing blocks at the four (4) corners of the boiler. Boiler base must be evenly supported under entire base.

Concrete over wood joists is considered combustible flooring. DO NOT operate on masonry floors, which may contain moisture.

- PROVIDE SERVICE CLEARANCE of at least 48" clearance from front jacket panel for servicing burner and removal of front tankless heater.
- For minimum clearances to combustible materials. See Figure 2.

NOTICE

Clearance to venting is for single wall vent pipe. If Type L vent is used, clearance may be reduced to the minimum required by the vent pipe manufacturer.

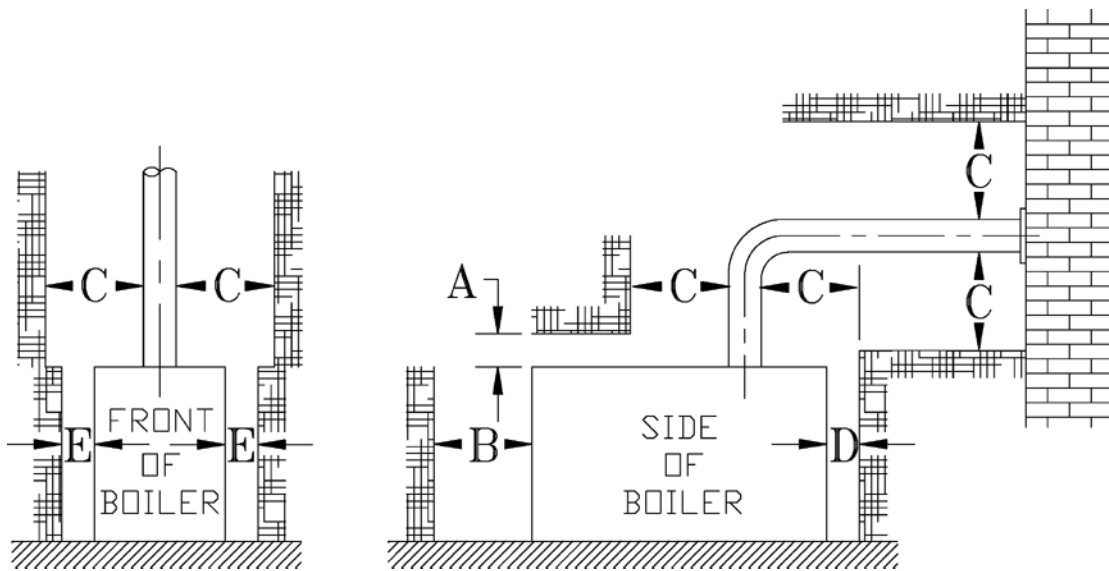

Figure 2: Minimum Clearances to Combustible Materials

A	B	C	D	E
Above	Front	Chimney Connector	Rear	Sides
18	48	18	18	18

NOTE 1: Listed clearances comply with American National Standard NFPA 31, Standard for the Installation of Oil Burning Equipment.

NOTE 2: AP-U™ Series boilers can be installed in rooms with clearances from combustible material as listed above. Listed clearances cannot be reduced for alcove or closet installations.

NOTE 3: For reduced clearances to combustible material, protection must be provided as described in the ANSI/NFPA 31 standard.

II: PRE-INSTALLATION (continued)

C. REMOVE CRATE

1. Remove all fasteners at crate skid.
2. Lift outside container and remove all other inside protective spacers and bracing. Remove accessory parts carton.

D. REMOVE BOILER FROM SKID

1. Remove four (4) hex head lag screws, attaching boiler base plate to shipping skid.
2. Carefully, walk boiler to the edge of the skid. Tilt the boiler back, allowing boiler base edge to rest on the floor, then, remove the skid.
3. Position boiler for final installation.

E. PROVIDE COMBUSTION AND VENTILATION

AIR. Local code provisions may apply and should be referenced.

WARNING

Adequate combustion and ventilation air must be provided to assure proper combustion and to maintain safe ambient air temperatures.

DO NOT install boiler where gasoline or other flammable vapors or liquids, or sources of hydrocarbons (i.e. bleaches, fabric softeners, etc.) are used or stored.

1. Determine volume of space (boiler room). Rooms communicating directly with the space in which the appliances are installed, through openings not furnished with doors, are considered a part of the space.
$$\text{Volume}(\text{ft}^3) = \text{Length}(\text{ft}) \times \text{Width}(\text{ft}) \times \text{Height}(\text{ft})$$
2. Determine total input of all appliances in the space. Add inputs of all appliances in the space and round the result to the nearest 1000 BTU per hour.
3. Determine type of space. Divide Volume by total input of all appliances in space. If the result is greater than or equal to 50 ft³/1000 BTU per hour, then it is considered an *unconfined space*. If the result is less than 50 ft³/1000 BTU per hour then the space is considered a *confined space*.
4. For boiler located in an *unconfined space of a conventionally constructed building*, the fresh air infiltration through cracks around windows and doors normally provides adequate air for combustion and ventilation.
5. For boiler located in a confined space or an unconfined space in a building of unusually tight construction, provide outdoor air with the use of two permanent openings which communicate directly or by duct with the outdoors or spaces (crawl or attic) freely communicating with the outdoors. Locate one opening within 12 inches of top of space. Locate remaining opening within 12 inches of bottom of space. Minimum dimension of air opening is 3 inches. Size each opening per following:
 - a. **Direct communication with outdoors.** Minimum free area of 1 square inch per 4,000 BTU per hour input of all equipment in space.
 - b. **Vertical ducts.** Minimum free area of 1 square inch per 4,000 BTU per hour input of all equipment in space. Duct cross-sectional area shall be same as opening free area.
 - c. **Horizontal ducts.** Minimum free area of 1 square inch per 2,000 BTU per hour input of all equipment in space. Duct cross-sectional area shall be same as opening free area.
Alternate method for boiler located within confined space. Use indoor air if two permanent openings communicate directly with additional space(s) of sufficient volume such that combined volume of all spaces meet criteria for unconfined space. Size each opening for minimum free area of 1 square inch per 1,000 BTU per hour input of all equipment in spaces, but not less than 100 square inches.
6. Louvers and Grilles of Ventilation Ducts
 - a. All outside openings should be screened and louvered. Screens used should not be smaller than 1/4 inch mesh. Louvers will prevent the entrance of rain and snow.
 - b. Free area requirements need to consider the blocking effect of louvers, grilles, or screens protecting the openings. If the free area of the louver or grille is not known, assume wood louvers have 20-25 percent free area and metal louvers and grilles have 60-75 percent free area.
 - c. Louvers and grilles must be fixed in the open position, or interlocked with the equipment to open automatically during equipment operation.

II: PRE-INSTALLATION (continued)

INSTALLATION INSTRUCTIONS FOR OPTIONAL SHIELD REQUIRED FOR COMBUSTIBLE FLOOR

This shield for combustible floors is intended for use **only** with the following New Yorker oil-fired boilers:

Use Part Number 6183504 for the following models:

AP-490U AP-590U AP-690U AP-790U
ADDS 4-3/16" TO BOILER HEIGHT

- 1) Place shield on combustible floor with "TOP" surface upward and "FRONT" surface directly below the expected position of the oil burner.
- 2) Locate shield such that clearances to combustible walls are as indicated in Figure 3. These dimensions will assure that the boiler jacket will be at least 18" from the side and rear walls and 48" from the front wall, as required by ANSI/NFPA 31.
- 3) Fasten shield to combustible floor to keep shield from shifting position during setting of boiler.
- 4) Set boiler squarely on top of shield such that base plate of boiler rests flat on top surface of shield and does not over-hang shield on any side. Confirm clearance to combustible walls. Refer to Figure 2.
- 5) **DO NOT** enclose boiler (including shield) on all four sides. Boiler may be enclosed on any three sides while maintaining minimum clearances shown in Figure 2 for each of those three sides.

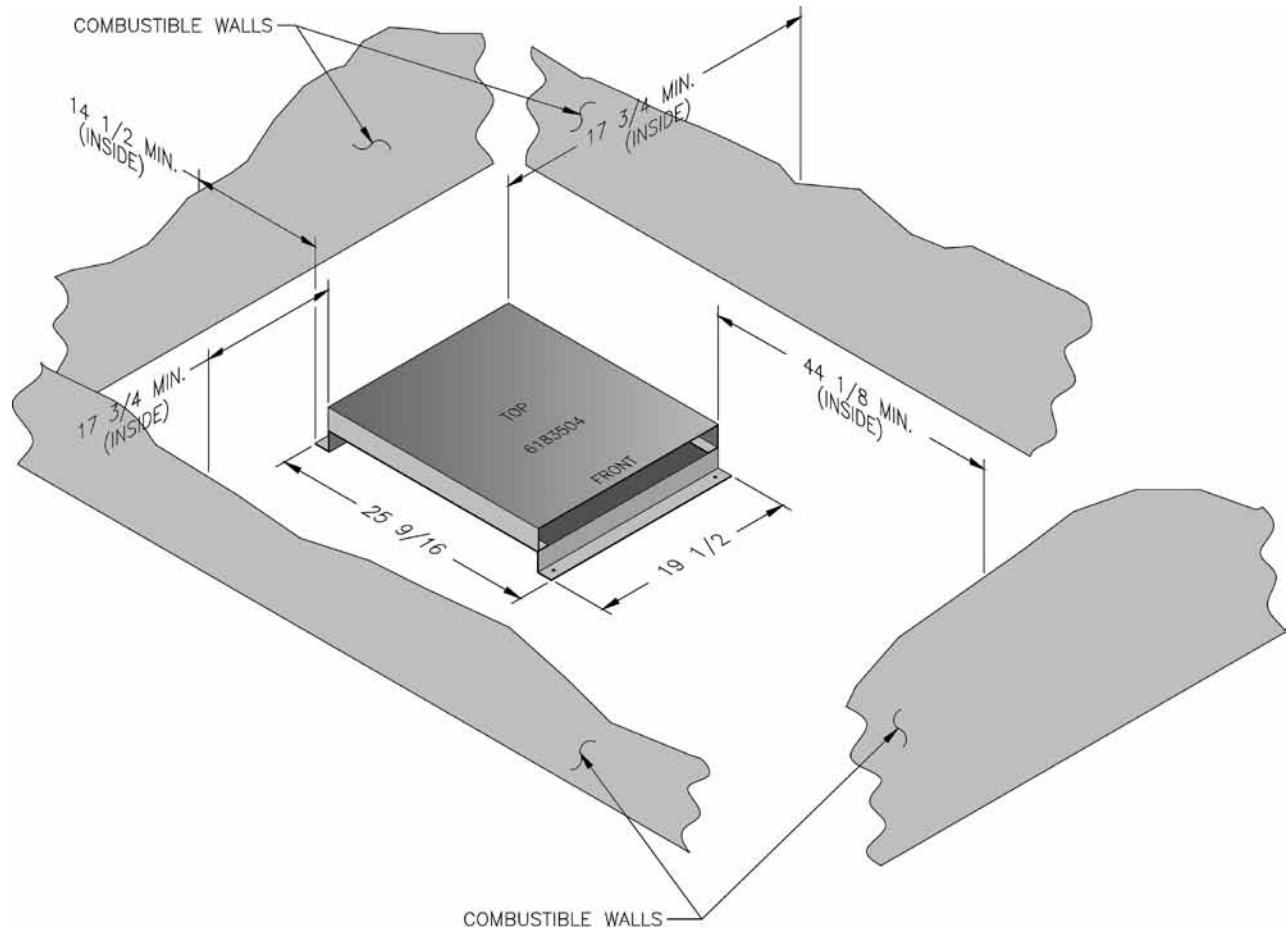

Figure 3: Floor Shield

III: WATER PIPING AND TRIM

WARNING

Failure to properly pipe boiler may result in improper operation and damage to boiler or structure.

Oxygen contamination of boiler water will cause corrosion of iron and steel boiler components, and can lead to boiler failure. New Yorker's Standard Warranty does not cover problems caused by oxygen contamination of boiler water or scale (lime) build-up caused by frequent addition of water.

A. DESIGN A PIPING SYSTEM and install boiler which will prevent oxygen contamination of boiler water and frequent water additions.

1. There are many possible causes of oxygen contamination such as:
 - a. Addition of excessive make-up water as a result of system leaks.
 - b. Absorption through open tanks and fittings.
 - c. Oxygen permeable materials in the distribution system.
2. In order to insure long product life, oxygen sources should be eliminated. This can be accomplished by taking the following measures:
 - a. Repairing system leaks to eliminate the need for addition of make-up water.
 - b. Eliminating open tanks from the system.
 - c. Eliminating and/or repairing fittings which allow oxygen absorption.
 - d. Use of non-permeable materials in the distribution system.
 - e. Isolating the boiler from the system water by installing a heat exchanger.
3. Connect System supply and return piping to boiler. See Figures 6A and 6B. Also, consult I=B=R, "Residential Hydronic Heating Installation and Design Guide". Maintain minimum 1/2 inch clearance from hot water piping to combustible materials.

- a. If this boiler is used in connection with refrigeration systems, the boiler must be installed so that the chilled medium is piped in parallel with the heating boiler using appropriate valves to prevent the chilled medium from entering the boiler. See Figure 4. Also, consult I=B=R, "Residential Hydronic Heating Installation and Design Guide".

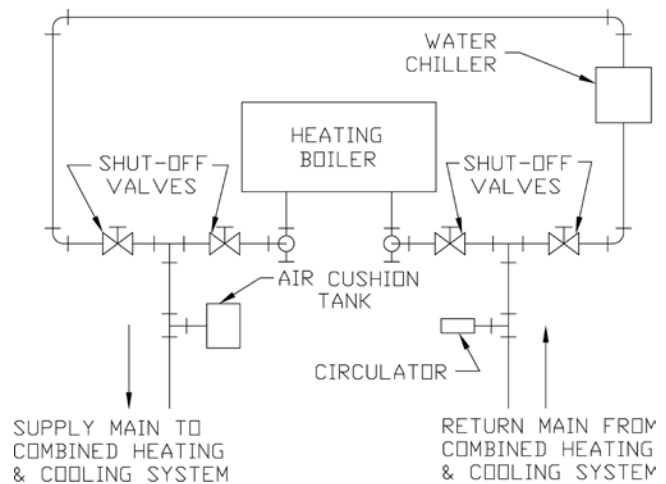

Figure 4: Recommended Piping for Combination Heating and Cooling (Refrigeration) System

- b. If this boiler is connected to heating coils located in air handling units where they may be exposed to refrigerated air, the boiler piping must be equipped with flow control valves to prevent gravity circulation of boiler water during the operation of the cooling system.
- c. If boiler is used with an Indirect-Fired Domestic Water Heater, install the Indirect-Fired Domestic Water Heater as a separate heating zone. Refer to the Indirect-Fired Domestic Water Heater Installation, Operating, and Service Instructions for additional information.
- d. Use a system bypass if the boiler is to be operated in a system which has a large volume or excessive radiation where low boiler water temperatures may be encountered (i.e. converted gravity circulation system, etc.) The bypass should be the same size as the supply and return lines with valves located in the bypass and return

WARNING

System supply and return piping must be connected to correct boiler pipe.

New Yorker recommends sizing the system circulator to supply sufficient flow (GPM) to allow a 20°F temperature differential in the system. When sizing the system circulator, the pressure drop of all radiators, baseboard and radiant tubing and all connecting piping must be considered.

III: WATER PIPING AND TRIM (continued)

line as illustrated in Figures 6A and 6B in order to regulate water flow for maintenance of higher boiler water temperature. Set the bypass and return valves to a half throttle position to start. Operate boiler until the system water temperature reaches its normal operating range. Adjust the valves to maintain 180°F to 200°F boiler water temperature and greater the 120°F return temperature. Adjust both valves simultaneously. Closing the boiler return valve while opening the bypass valve will raise the boiler return temperature. Opening the boiler return valve while closing the by-pass valve will lower the boiler return temperature.

- e. A water boiler installed above radiation level must be provided with a low water cutoff device as part of the installation.

- B. **INSTALL SAFETY RELIEF VALVE.** See Figures 5, 6A and 6B. Safety Relief Valve must be installed with spindle in the vertical position. Installation of the relief valve must be consistent with ANSI/ASME Boiler and Pressure Vessel Code, Section IV.

WARNING

Installation is NOT complete unless a safety relief valve is installed as shown in Figure 5. Safety (relief) valve discharge piping must be piped near floor to eliminate potential of severe burns. DO NOT pipe in any area where freezing could occur. DO NOT install any shut-off valves, plugs or caps.

- C. **AIR VENT.** An air vent or purge must be incorporated in the system to easily remove air from the boiler when the system is filled. The boiler has a built in dip tube which works with the air vent to clear the boiler of air. Improper application of the air vent will cause steaming in the boiler. See Figures 5, 6A and 6B.

- D. **INSTALL DRAIN VALVE** in return piping. See Figures 6A and 6B.

- E. **OIL, GREASE, AND OTHER FOREIGN MATERIALS** which accumulate in new hot water and a new or reworked system should be boiled out, and then thoroughly flushed. A qualified water treatment chemical specialist should be consulted for recommendations regarding appropriate chemical compounds and concentrations which are compatible with local environmental regulations.

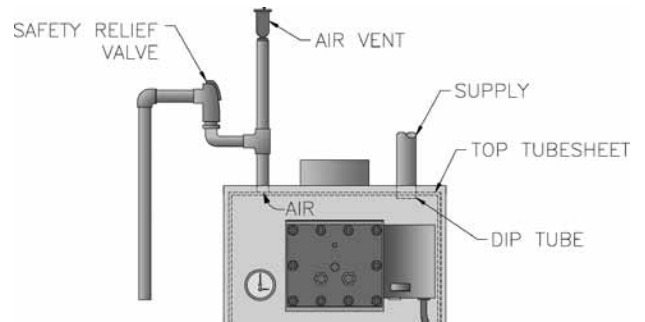

Figure 5: Air Vent and Safety Relief Valve Installation Detail

- F. **AFTER THE BOILER AND SYSTEM HAVE BEEN CLEANED** and flushed, and before refilling the entire system add appropriate water treatment chemicals, if necessary, to bring the pH between 7 and 11.
- G. **CONNECT TANKLESS HEATER PIPING AS SHOWN IN FIGURE 7.** See Table 3 for Tankless Heater Rating.

WARNING

Install automatic mixing valve at tankless heater outlet to avoid risk of burns or scalding due to excessively hot water at fixtures. Adjust and maintain the mixing valve in accordance with the manufacturer's instructions. DO NOT operate tankless heater without mixing valve.

III: WATER PIPING AND TRIM (continued)

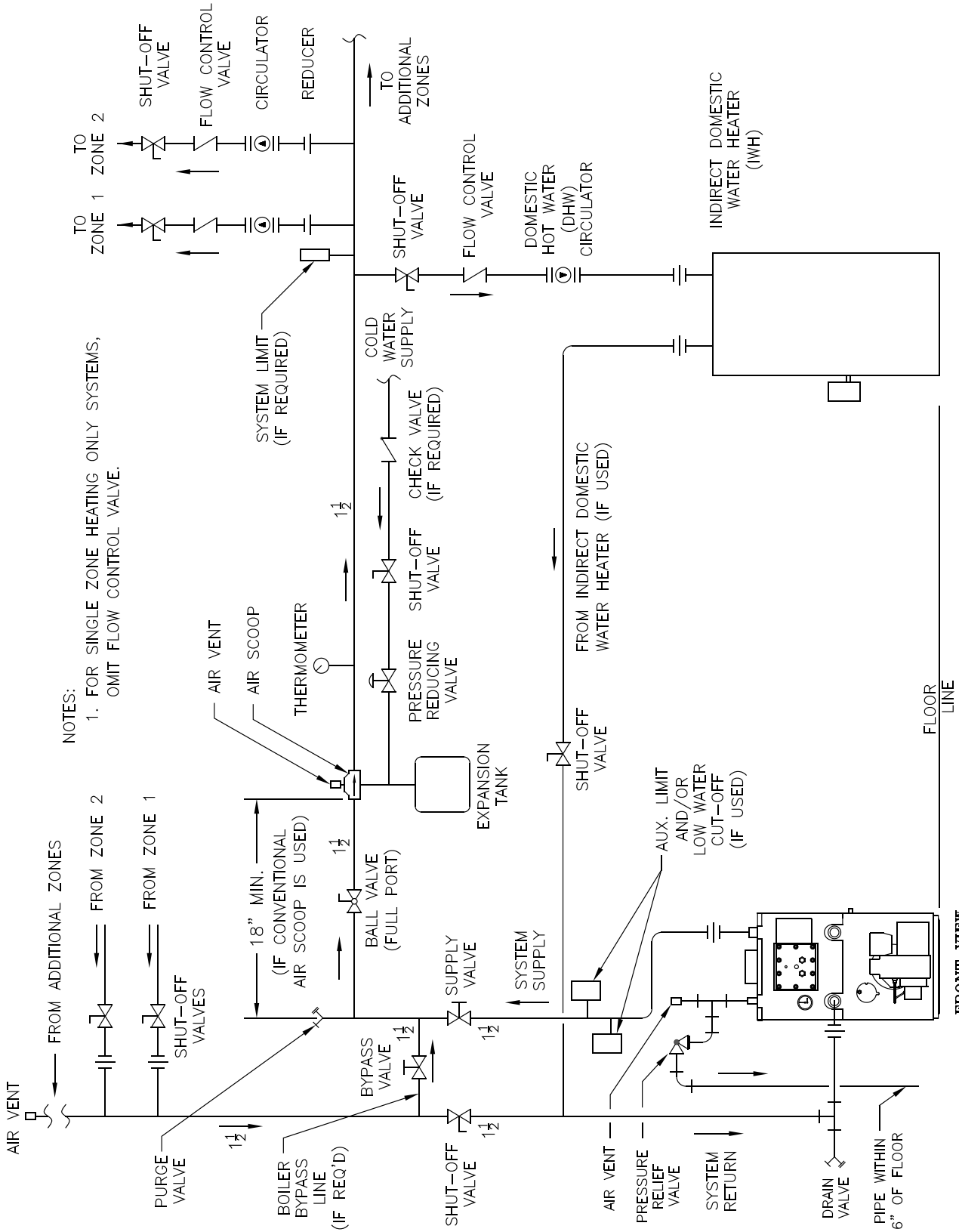

NOTES:
 1. FOR SINGLE ZONE HEATING ONLY SYSTEMS, OMIT FLOW CONTROL VALVE.

FRONT VIEW

Figure 6A: Recommended Boiler Piping for Circulator Zoned Heating Systems, Supply Side Circulator

III: WATER PIPING AND TRIM (continued)

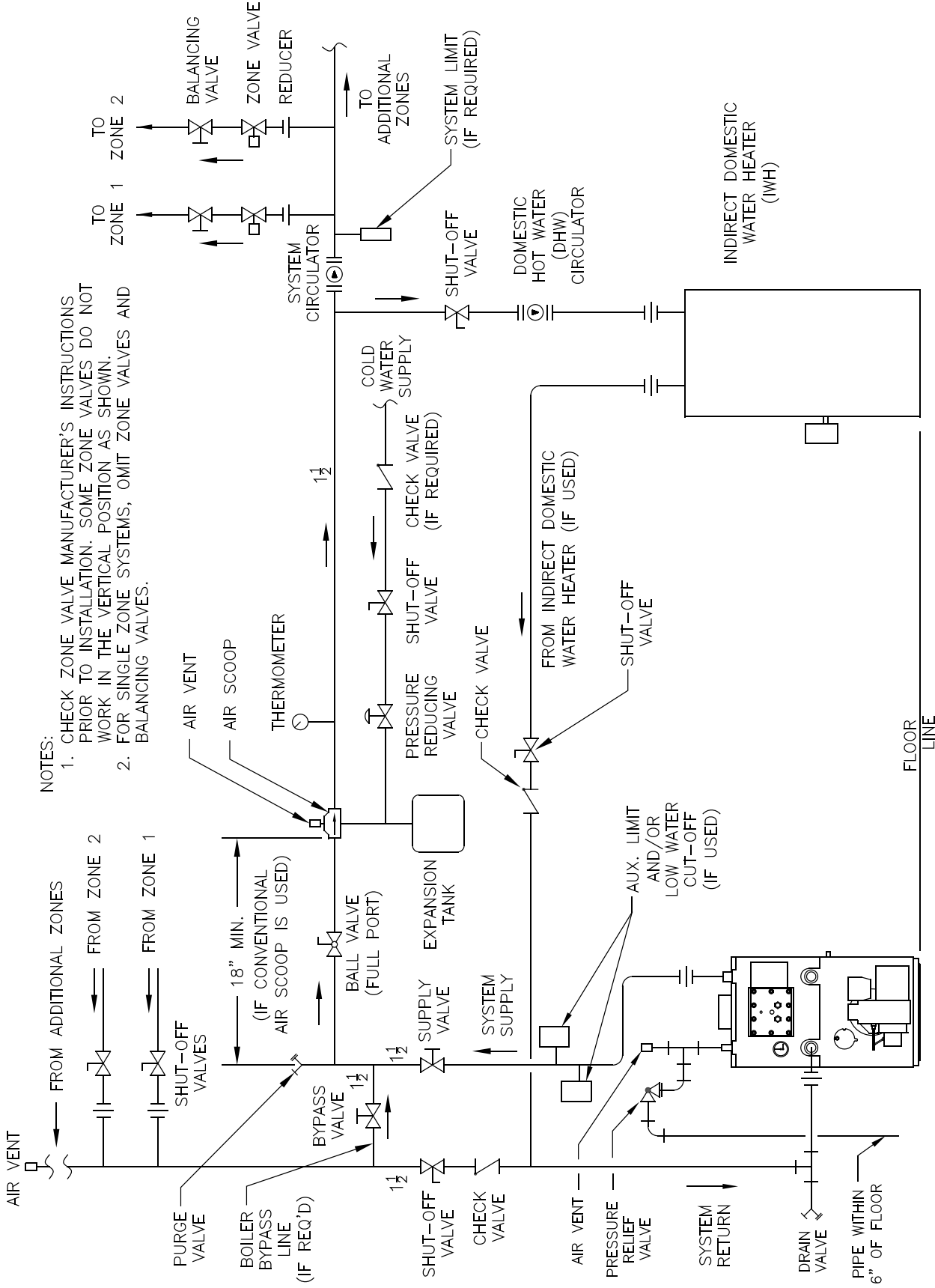

NOTES:
 1. CHECK ZONE VALVE MANUFACTURER'S INSTRUCTIONS PRIOR TO INSTALLATION. SOME ZONE VALVES DO NOT WORK IN THE VERTICAL POSITION AS SHOWN.
 2. FOR SINGLE ZONE SYSTEMS, OMIT ZONE VALVES AND BALANCING VALVES.

Figure 6B: Boiler Piping for Zone Valve Zoned Heating Systems, Supply Side Circulator

III: WATER PIPING AND TRIM (continued)

THE FOLLOWING GUIDELINES SHOULD BE FOLLOWED WHEN PIPING THE TANKLESS HEATER:

1. **FLOW REGULATION** — If flow through the heater is greater than its rating, the supply of adequate hot water may not be able to keep up with the demand. For this reason a flow regulator matching the heater rating should be installed in the cold water line to the heater. The flow regulator should preferably be located below the inlet to the heater and a minimum of 3' away from the inlet so that the regulator is not subjected to excess temperatures that may occur during "off" periods when it is possible for heat to be conducted back through the supply line. The flow regulator also limits the flow of supply water regardless of inlet pressure variations in the range of 20 to 125 psi.
2. **TEMPERING OF HOT WATER** — Installation of an automatic mixing valve will lengthen the delivery of the available hot water by mixing some cold water with the hot. This prevents the possibility of scalding hot water at the fixtures. In addition, savings of hot water will be achieved since the user will not waste as much hot water while seeking a water temperature. Higher temperature hot water required by dishwashers and automatic washers is

possible by piping the hot water from the heater prior to entering the mixing valve. The mixing valve should be "trapped" by installing it below the cold water inlet to heater to prevent lime formation in the valve. Refer to Figure 7.

3. **FLUSHING OF HEATER** — All water contains some sediment which settles on the inside of the coil. Consequently, the heater should be periodically backwashed. This is accomplished by installing hose bibs as illustrated and allowing water at city pressure to run into hose bib A, through the heater, and out hose bib B until the discharge is clear. The tees in which the hose bibs are located should be the same size as heater connections to minimize pressure drop.
4. **HARD WATER** — A water analysis is necessary to determine the hardness of your potable water. This is applicable to some city water and particularly to well water. An appropriate water softener should be installed based on the analysis and dealer's recommendation. This is not only beneficial to the tankless heater but to piping and fixtures plus the many other benefits derived from soft water.

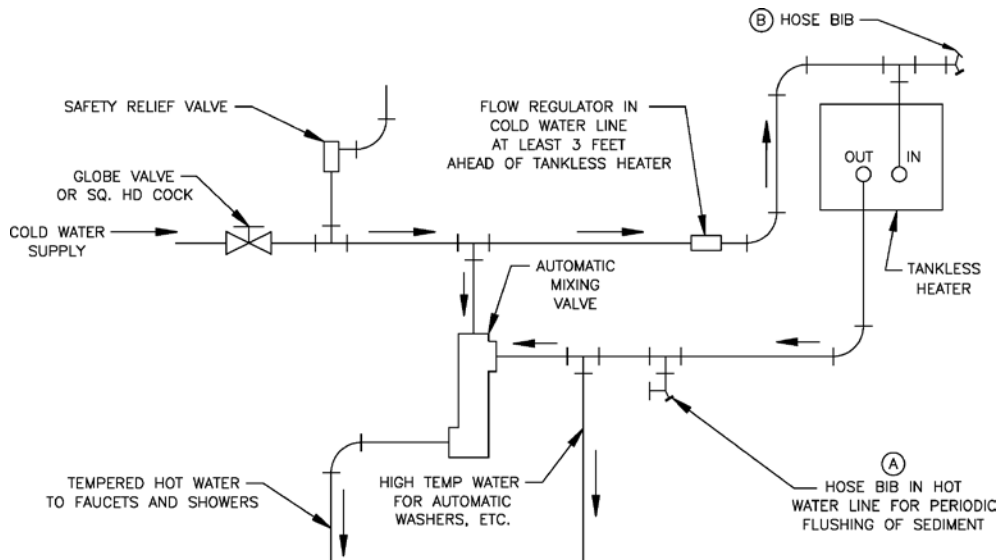

Figure 7: Schematic Tankless Heater Piping

TABLE 3: TANKLESS HEATER RATINGS

Boiler Model	Tankless Heater Model	
	S-5A	
	GPM	PSID
AP-490U	3½	15
AP-590U	3¾	25
AP-690U		
AP-790U		

IV: VENTING

A. GENERAL GUIDELINES.

1. Vent system installation must be in accordance with these instructions and applicable provisions of local building codes. Contact local building or fire officials about restrictions and installation inspection in your area.
2. The AP-U Series is designed to be vented into a fireclay tile-lined masonry chimney or chimney constructed from type-L vent or a factory built chimney that complies with the type HT requirements of UL103. The chimney or vent pipe shall have a sufficient draft at all times, to assure safe proper operation of the boiler. See Figure 8 for recommended installation.
 - a. Install a draft regulator (supplied by installer) following the instructions furnished with the regulator. See Figure 9 for alternate regulator locations.
 - b. With any new or replacement installation the chimney has to be considered. Chimneys that have a high heat loss become less suitable as the heat loss of the home goes down and the efficiency of the boiler goes up. Most homes have a chimney appropriate for the fuel and the era in which the home was built. That may have been a coal fired or an inefficient oil fired boiler built into a home without insulation or storm windows. With increasing fuel prices that home probably has been insulated and fitted with storm windows so that the heat loss of the home has been reduced. This requires less fuel to be burned and sends less heat up the chimney. A new boiler probably has a higher efficiency than the boiler being replaced. That probably

means that the stack temperature from the new boiler will be lower than that from the old boiler and with less room air being drawn up the chimney to dilute the stack gases. The combination of a large uninsulated chimney, reduced firing rate, reduced firing time, lower stack temperature and less dilution air can, in some cases, contribute to the condensing of small amounts of water vapor in the chimney. Such condensation, when it occurs, can cause chimney deterioration. In extreme cases, the chimney may have to be lined to insulate the chimney and thus prevent the condensation. The addition of dilution air into the chimney may assist in drying the chimney interior surfaces. A massive chimney on a cold, or exposed outside wall may have produced adequate draft when it was fired with a higher input and greater volumes of heated gases. With reduced input and volume, the draft may be severely affected. In one instance our research showed a new chimney of adequate sizing produced only $-.035''$ W.C. after 30 minutes of continuous firing at 13.0% CO_2 . Outside wall chimneys take longer to heat up and can have $.00''$ W.C. draft at burner start-up. You may have to consider a special alloy chimney flue liner with insulation around it and stabilizing draft cap or even a draft inducing fan in severe cases.

- c. For the same reasons as in (2.) above, heat extractors mounted into the breeching are not recommended.
3. For minimum clearances to combustible materials refer to Figure 2.

IV: VENTING (continued)

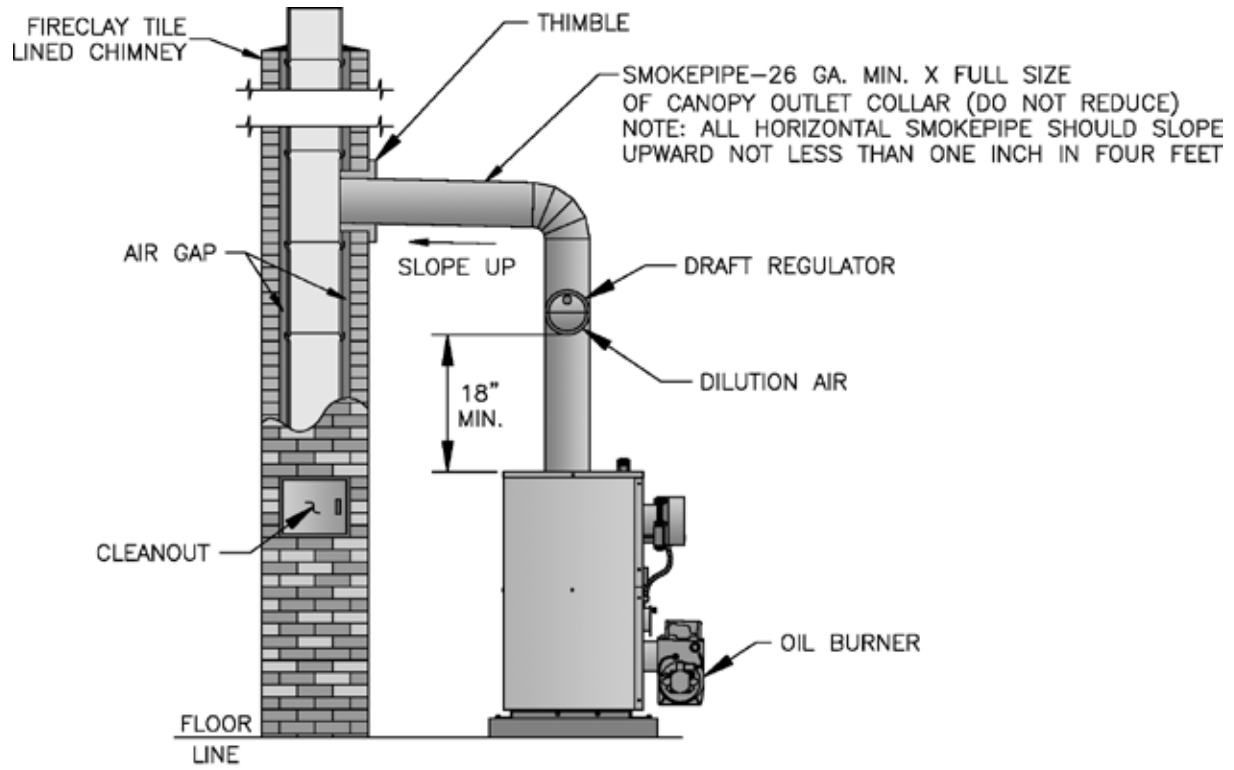

LEFT SIDE VIEW

Figure 8: Recommended Smokepipe Arrangement and Chimney Requirements

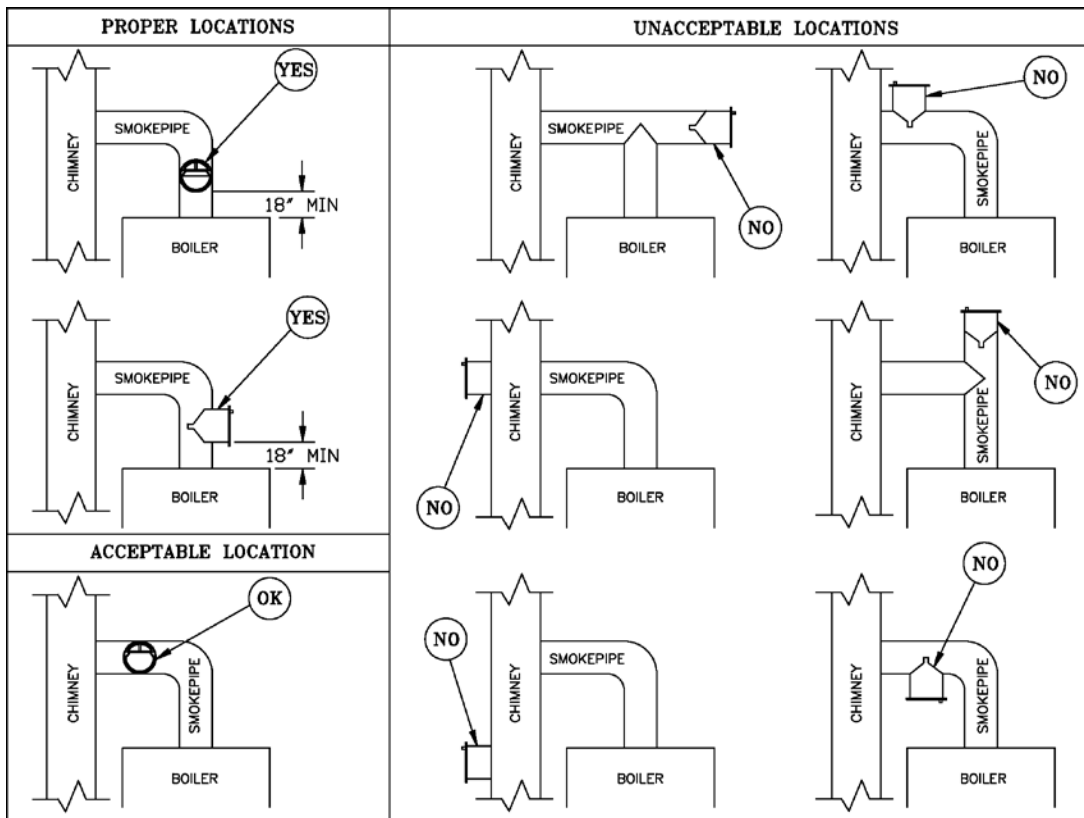

Figure 9: Draft Regulator Locations

V: ELECTRICAL

DANGER

Positively assure all electrical connections are unpowered before attempting installation or service of electrical components or connections of the boiler or building. Lock out all electrical boxes with padlock once power is turned off.

WARNING

Failure to properly wire electrical connections to the boiler may result in serious physical harm.

Electrical power may be from more than one source. Make sure all power is off before attempting any electrical work.

Each boiler must be protected with a properly sized fused disconnect.

Never jump out or make inoperative any safety or operating controls.

The wiring diagrams contained in this manual are for reference purposes only. Refer to the wiring diagram of any controls used with the boiler. Read, understand and follow all wiring instructions supplied with the controls.

A. GENERAL

1. Install wiring and electrically ground boiler in accordance with requirements of the authority having jurisdiction, or in absence of such requirements the National Electrical Code, ANSI/NFPA 70, and/or the CSA C22.1 Electric Code.
2. A separate electrical circuit must be run from the main electrical service with an over-current device/disconnect in the circuit. A service switch is recommended and may be required by some local jurisdictions.
3. Wiring should conform to Figure 10 and/or 11.

B. SYSTEM CONTROLS AND WIRING

1. Refer to National Electric Code or Local Electric Codes for proper size and type of wire required. Follow Code.
2. Use anti-short bushings on all wiring passing through boiler jacket, junction boxes and/or control boxes.
3. Use armored cable (BX) over all exposed line voltage wiring.
4. If an indirect water heater is used, use priority zoning. **DO NOT** use priority zoning for Hydro-Air Systems.
5. Single Zone System – Refer to Figure 10 or 11 for the electrical diagram for this type of system. Connect the system circulator wire leads to the proper locations on the Aquastat control, L7224/L7248. See Figure 10 or 11.

- C. **INSTALL A ROOM THERMOSTAT** on an inside wall about four feet above floor. Never install thermostat on an outside wall or where it will be influenced by drafts, hot or cold water pipes, lighting fixtures, television, rays of the sun or near a fireplace. Keep large furniture away from thermostat so there will be free movement of room air around this control.

Connect the thermostat to the 'T-T' terminals on the L7224 or L7248 control.

Heat Anticipator in Thermostat should be set to .1 amps. If system tends to overheat above the thermostat's temperature setting, reduce heat anticipator setting by .1 or .2 amps. If system tends to short cycle without reaching desired room temperature, increase heat anticipator setting by .1 or .2 amps.

WARNING

The maximum allowable current for each circulator is 5 amps at 120V AC. For circulators with higher amp ratings, you must install a circulator relay or starter coil to provide line voltage to the circulator and connect only the relay or starter coil to boiler terminals. The combined boiler and circulator amperage must not exceed 15 amps. Install over-current protection in accordance with authority having jurisdiction or, in the absence of such requirements, follow the National Electric Code, NFPA 70, and/or CSA C22.1 Electrical Code. **DO NOT provide over-current protection greater than 15 amperes.**

V: ELECTRICAL (continued)

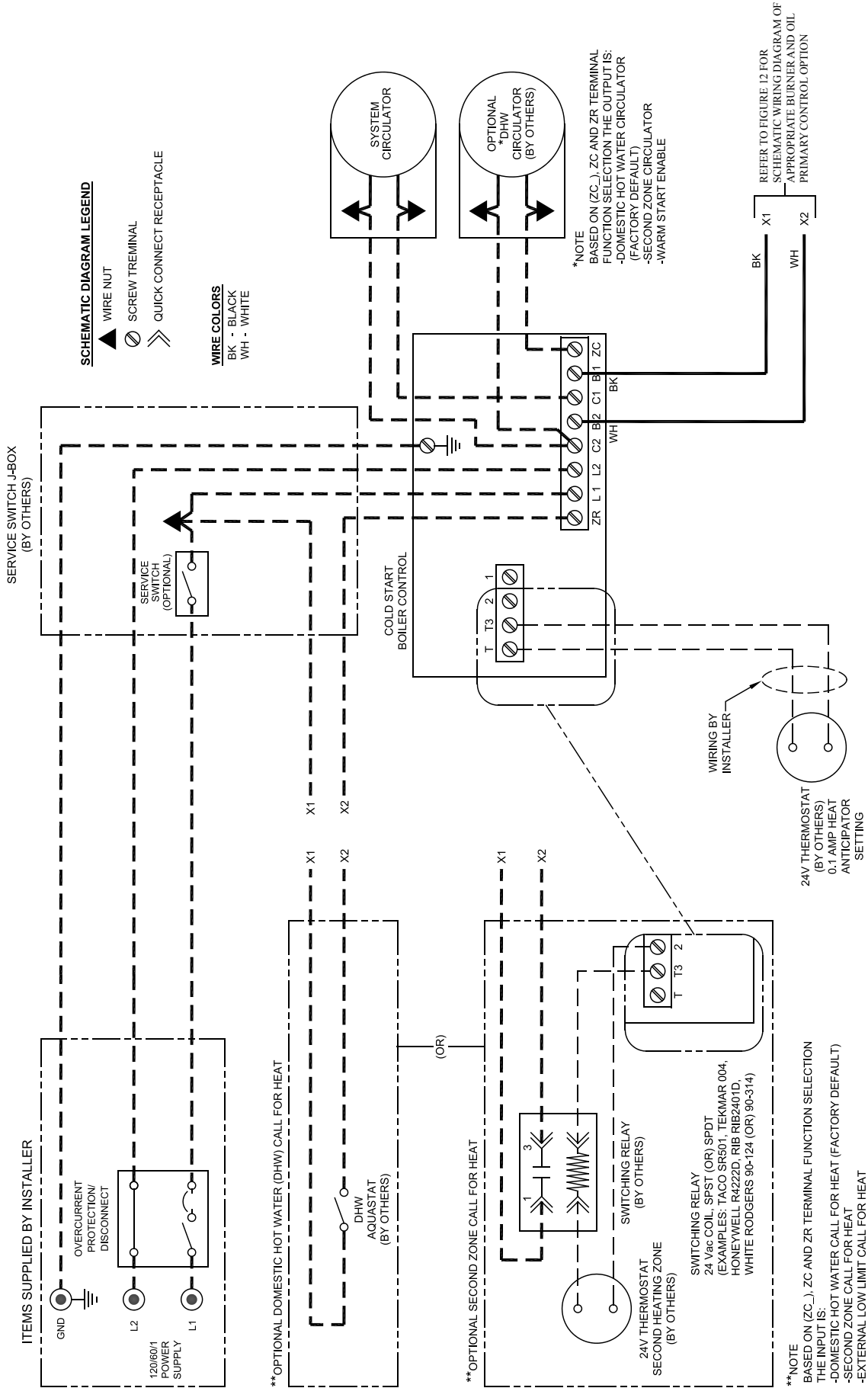

Figure 10: Schematic Wiring Diagram, without Tankless Heater, Cold Start Control (Beckett and Riello Burners)

V: ELECTRICAL (continued)

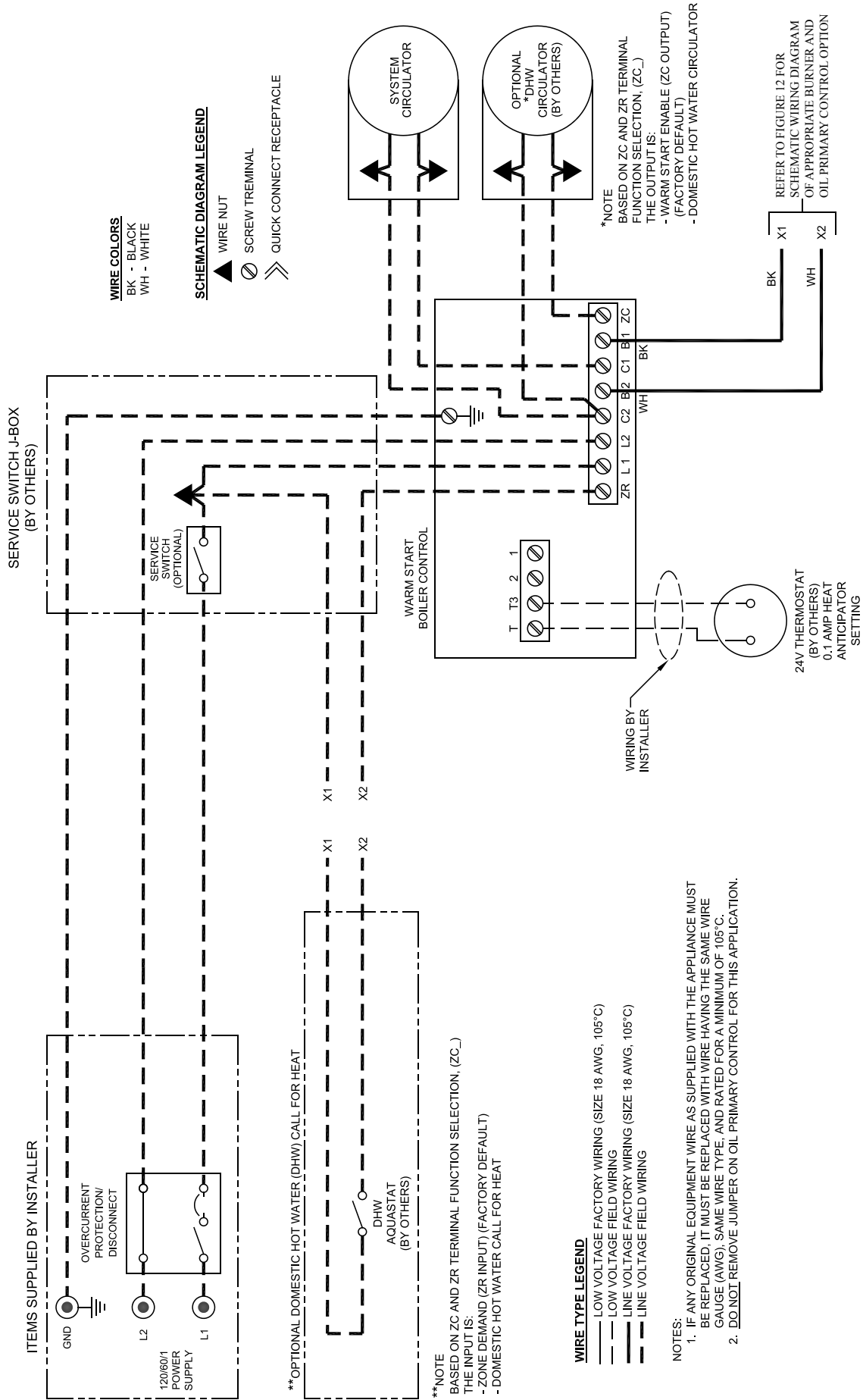
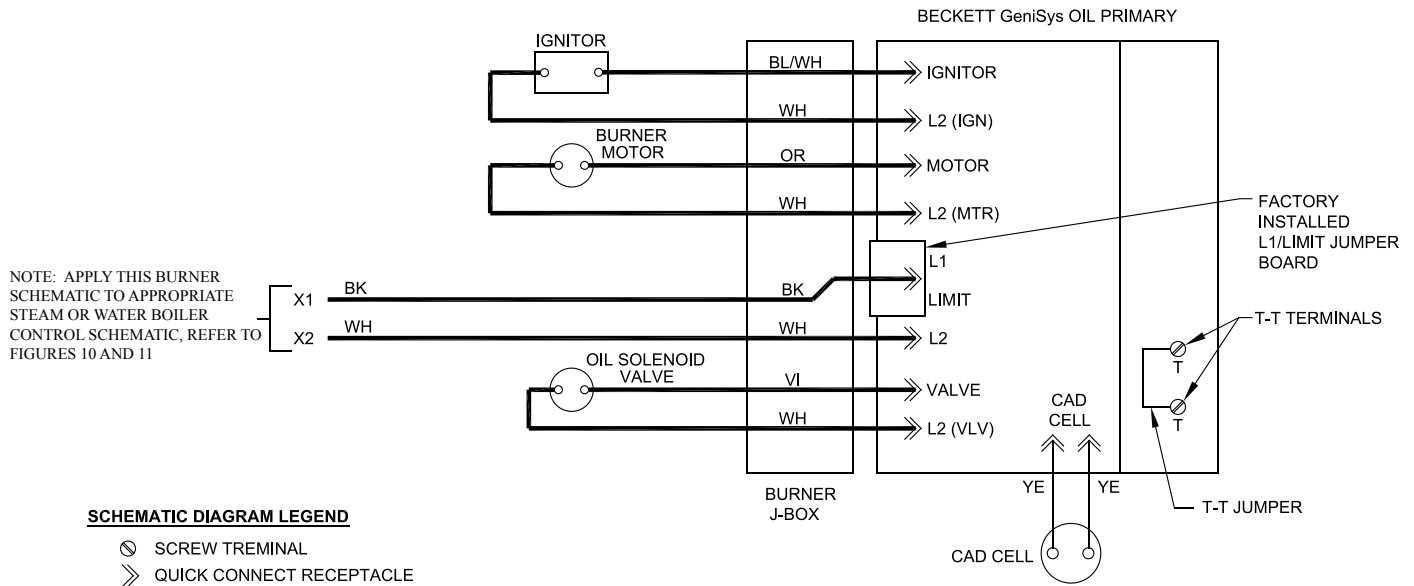

Figure 11: Schematic Wiring Diagram, with Tankless Heater, Warm Start Control (Beckett and Riello Burners)

V: ELECTRICAL (continued)



BECKETT AFG BURNER WITH GeniSys OIL PRIMARY CONTROL

WIRE COLORS

- BK - BLACK
- BL/WH - BLUE W/ WHITE TRACER
- WH - WHITE
- VI - VIOLET
- YE - YELLOW
- OR - ORANGE
- RD - RED

WIRE TYPE LEGEND

- LOW VOLTAGE FACTORY WIRING (SIZE 18 AWG, 105°C)
- LOW VOLTAGE FIELD WIRING
- ===== LINE VOLTAGE FACTORY WIRING (SIZE 18 AWG, 105°C)
- LINE VOLTAGE FIELD WIRING

NOTES:

1. IF ANY ORIGINAL EQUIPMENT WIRE AS SUPPLIED WITH THE APPLIANCE MUST BE REPLACED, IT MUST BE REPLACED WITH WIRE HAVING THE SAME WIRE GAUGE (AWG), SAME WIRE TYPE, AND RATED FOR A MINIMUM OF 105°C.

NOTE: APPLY THIS BURNER SCHEMATIC TO APPROPRIATE STEAM OR WATER BOILER CONTROL SCHEMATIC, REFER TO FIGURES 10 AND 11

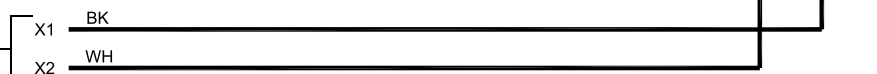

RIELLO 40 SERIES BURNER WITH RIELLO OIL PRIMARY CONTROL

Figure 12: Schematic Wiring Diagrams For All Burner Options w/Variou Oil Primary Controls

VI: OIL PIPING

A. GENERAL.

1. Use flexible oil line(s) so that burner can be removed without disconnecting the oil supply.
2. A supply line fuel oil filter is recommended as a minimum for all firing rates but a pleated paper fuel oil filter is recommended for the lowest firing rate application to prevent nozzle fouling.
3. Use Flared fittings only. **DO NOT** use compression fittings.
4. Use of a high efficiency micron filter (Garber or equivalent) in addition to conventional filter is highly recommended.

B. SINGLE-PIPE OIL LINES.

1. Standard burners are provided with single-stage 3450 rpm fuel units with the bypass plug removed for single-pipe installations.
2. The single-stage fuel unit may be installed single-pipe with gravity feed or lift. Maximum allowable lift is 8 feet. See Figure 13.

NOTICE

Oil piping must be absolutely airtight or leaks or loss of prime may result. Bleed line and fuel unit completely.

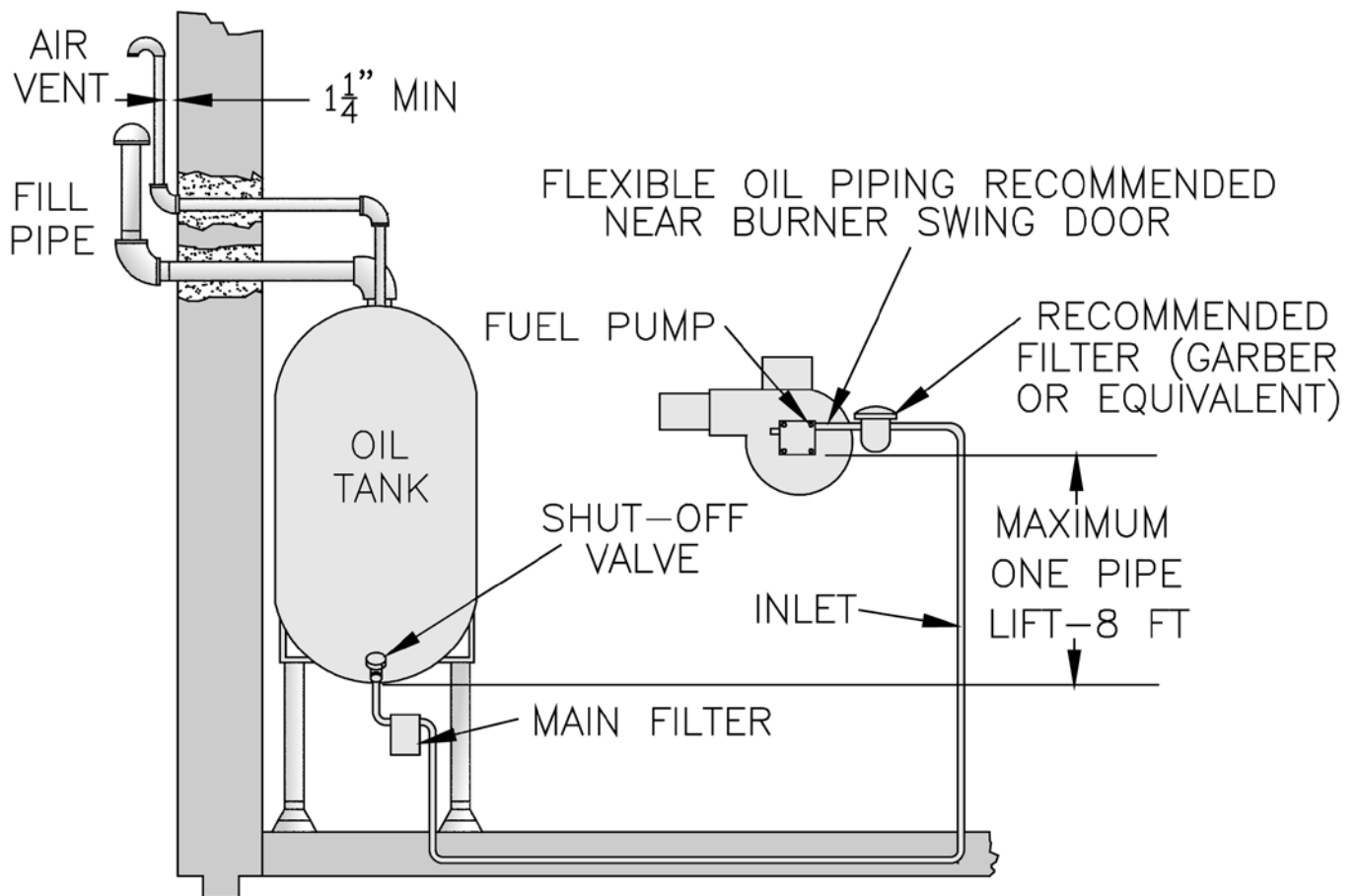

Figure 13: Single-Pipe Installation

VI: OIL PIPING (continued)

TABLE 4: SINGLE STAGE UNITS (3450 RPM)
Two Pipe Systems

Lift "H" (See Figure)	Maximum Length of Tubing "H" + "R" (See Figure)	
	3/8" OD Tubing (3 GPH)	1/2" OD Tubing (3 GPH)
0'	84'	100'
1'	78'	100'
2'	73'	100'
3'	68'	100'
4'	63'	100'
5'	57'	100'
6'	52'	100'
7'	47'	100'
8'	42'	100'
9'	36'	100'
10'	31'	100'
11'	26'	100'
12'	21'	83'
13'	---	62'
14'	---	41'

TABLE 5: TWO-STAGE UNITS (3450 RPM)
Two Pipe Systems

Lift "H" (See Figure)	Maximum Length of Tubing "H" + "R" (See Figure)	
	3/8" OD Tubing (3 GPH)	1/2" OD Tubing (3 GPH)
0'	93'	100'
2'	85'	100'
4'	77'	100'
6'	69'	100'
8'	60'	100'
10'	52'	100'
12'	44'	100'
14'	36'	100'
16'	27'	100'
18'	---	76'

C. TWO-PIPE OIL LINES

- For two-piped systems, where more lift is required, the two-stage fuel unit is recommended. Table 4 (single-stage) and Table 5 (two-stage) show allowable lift and lengths of 3/8 inch and 1/2 inch OD tubing for both suction and return lines. Refer to Figure 14.

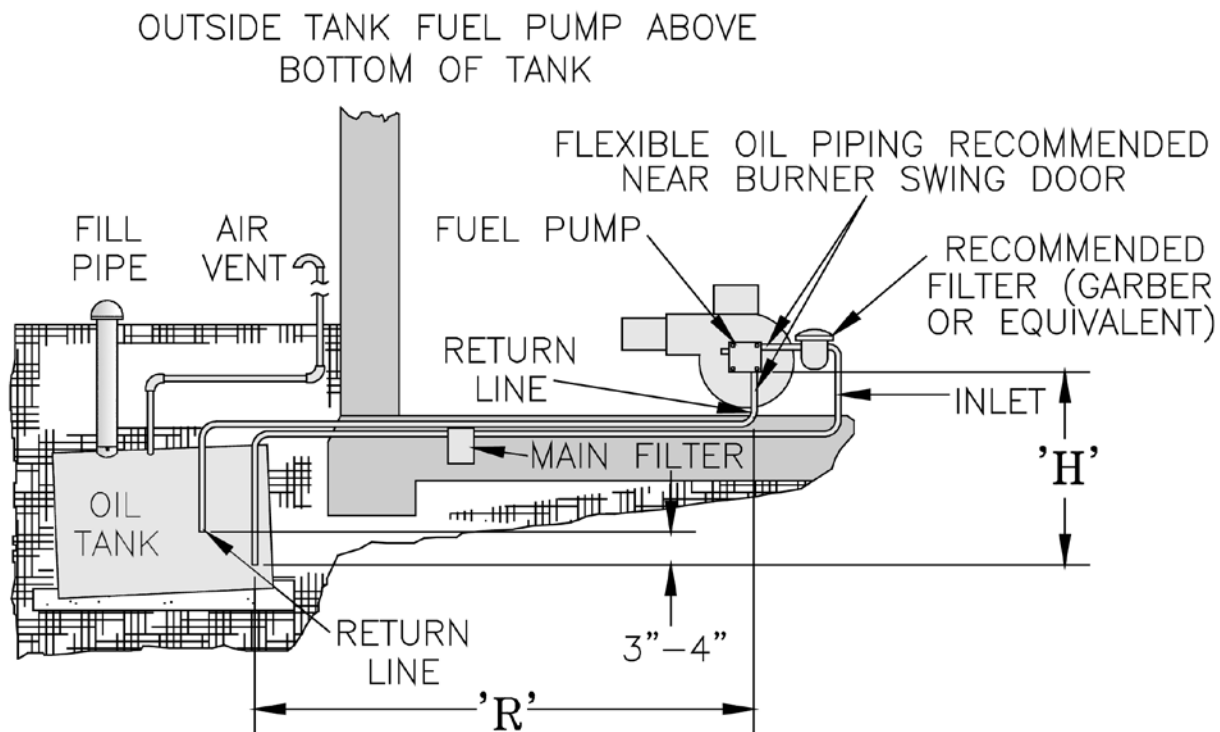

Figure 14: Two-Pipe Installation

VII: SYSTEM START-UP

A. ALWAYS INSPECT INSTALLATION BEFORE STARTING BURNER.

1. Verify that the venting, water piping, oil piping, and electrical system are installed properly. Refer to Installation Instructions contained in this manual.
2. Confirm all electrical, water and oil supplies are turned off at the source and that the vent is clear from obstructions.

WARNING

Completely read, understand and follow all instructions in this manual before attempting start up.

B. FILL HEATING SYSTEM WITH WATER.

CLEAN HEATING SYSTEM if boiler water is dirty. Refer to Maintenance and Service Instructions Section of this manual for proper cleaning instructions for water boilers.

1. Fill entire heating system with water and vent air from system. Use the following procedure on a series loop or multi-zoned system installed as per Figures 6A, and 6B, to remove air from system when filling:
 - a. Close full port ball valve in boiler system piping.
 - b. Isolate all zones by closing zone valves or shut-off valves in supply and return of each zone(s).
 - c. Attach a hose to vertical purge valve in boiler system piping.
(**Note** - Terminate hose in five gallon bucket at a suitable floor drain or outdoor area).
 - d. Starting with one zone at a time, open zone valve or shut-off valve in boiler supply and return piping.
 - e. Open purge valve.
 - f. Open shut-off valve in cold water supply piping located between the air scoop and expansion tank.
 - g. Allow water to overflow from bucket until discharge from hose is bubble free for 30 seconds.
 - h. When zone is completely purged of air, close zone valve or shut-off valve. Open zone valve to the next zone to be purged. Repeat this step until all zones have been purged. At completion, open all zone valves.
 - i. Close purge valve, continue filling the system until the pressure gauge reads 12 psi. Close shut-off valve in cold water supply piping.

Note - If make-up water line is equipped with pressure reducing valve, system will automatically fill to 12 psig.

NOTICE

If make-up water line is equipped with pressure reducing valve, system will automatically fill to 12 psi. Follow fill valve manufacturer's instructions.

WARNING

The maximum operating pressure of this boiler is posted on the ASME Data Label located on the top of the boiler. Never exceed this pressure. DO NOT plug safety or relief valve.

- j. Open full port ball valve in boiler system piping.
- k. Remove hose from purge valve.
- l. Confirm that the boiler and system have no water leaks.

C. CHECK CONTROL, WIRING AND BURNER to be sure that all connections are tight and burner is rigid, that all electrical connections have been completed and fuses installed, and that oil tank is filled and oil lines have been tested.

D. LUBRICATION. Follow instruction on burner and circulator label to lubricate, if oil lubricated. Most motors currently used on residential type burners employ permanently lubricated bearings and thus **DO NOT** require any field lubrication. Water lubricated circulators **DO NOT** need field lubrication.

E. ADJUST CONTROL SETTINGS with burner service switch turned "ON".

1. **SET ROOM THERMOSTAT** about 10°F below room temperature.
2. **PRESS RED RESET BUTTON** on Oil Primary Control. Hold button for ten (10) seconds and release to reset primary control.
3. **WATER BOILERS WITHOUT TANKLESS HEATERS** are equipped with an Intelligent Oil Boiler Control (Boiler Control). The Boiler Control is factory programmed with a High Limit setpoint of 180°F. The High Limit setpoint is adjustable between 140°F and 240°F. This temperature may be varied to suit the installation requirements.
HIGH LIMIT DIFFERENTIAL is factory programmed at 15°F and is adjustable between 10°F and 30°F.

VII: SYSTEM START-UP (continued)

4. WATER BOILERS WITH TANKLESS HEATERS are equipped with a Warm Start Intelligent Oil Boiler Control (Warm Start Boiler Control). The Warm Start Boiler Control is factory programmed with a High Limit setpoint of 180°F. The High Limit setpoint is adjustable between 140°F and 240°F. High Limit Differential is factory programmed at 10°F. Additionally, the Warm Start Boiler Control is factory programmed with a Low Limit setpoint of 110°F. The Low Limit setpoint is adjustable between 110°F and 220°F. These temperatures may be varied to suit the installation requirements.

5. CHECKOUT

Put the system into operation and observe at least one complete cycle to make sure that the controller operates properly. See Troubleshooting Section to use LED to assist in determining system operation.

F. CHECK OIL BURNER BEFORE STARTING.

1. CHECK BURNER SETTINGS and readjust if necessary, see Burner Specifications, Table 6 and Table 7.

2. Beckett AFG Burners

This Beckett AFG burner is equipped with a non-adjustable Fixed "F" Series Head, the number is stamped on the head.

- Remove Gun Assembly.
- Verify nozzle size, head size, gun setting, and positioning of electrodes. This information is shown in Figure 15, and Beckett Burner Specifications, Table 6. Replace Gun Assembly.
- Check burner air band and air shutter settings. Readjust if necessary, see Burner Specifications Table 6.
- OPEN ALL OIL LINE VALVES.
- Attach a plastic hose to fuel pump vent fitting and provide a pan to catch the oil.
- OPEN FLAME OBSERVATION PORT COVER on burner swing door.

3. Riello 40 Series Burners

Use the following procedure to complete the inspection, check the settings and to change the nozzle. Refer also to *Model F3 & F5 Installation Manual, Riello 40 Series Residential Oil Burners* (C6501010).

- Installation/Removal of Drawer Assembly**, refer to Figure 16.
 - Removal:
 - Disconnect oil delivery tube nut from pump.
 - Loosen SCREW (3), and then unplug PRIMARY CONTROL (1) by carefully pulling it back and then up.

TABLE 6: BECKETT AFG BURNERS

Boiler Model	Firing Rate (GPH)	Nozzle	Air		Settings	
			Shutter	Band	Head (stop screw)	Pump Pressure
*AP-490U	0.75	0.65 - 80°AB DANFOSS	7	0	N/A	140
AP-590U	1.00	0.85 - 80°B HAGO	4	0	N/A	140
AP-690U	1.10	0.90 - 80°B HAGO	6	0	N/A	140
AP-790U	1.35	1.10 - 80°B HAGO	8	0	N/A	140

* Equipped with low firing rate baffle

TABLE 7: RIELLO 40 SERIES BURNER SPECIFICATIONS

Boiler Model	Firing Rate (GPH)	Burner Model	Nozzle (DELAVAN)	Air Gate Setting	Turbulator Setting	Pump Pressure (PSIG)	Combustion Head	Insertion Depth
AP-490U	0.75	40F3	0.65 - 60W	2.75	1	145	VSBT	1¼
AP-590U	1.00	40F5	0.85 - 80B		0			
AP-690U	1.10		0.90 - 80B	3				
AP-790U	1.35		1.10 - 80B	3.5	2			

VII: SYSTEM START-UP (continued)

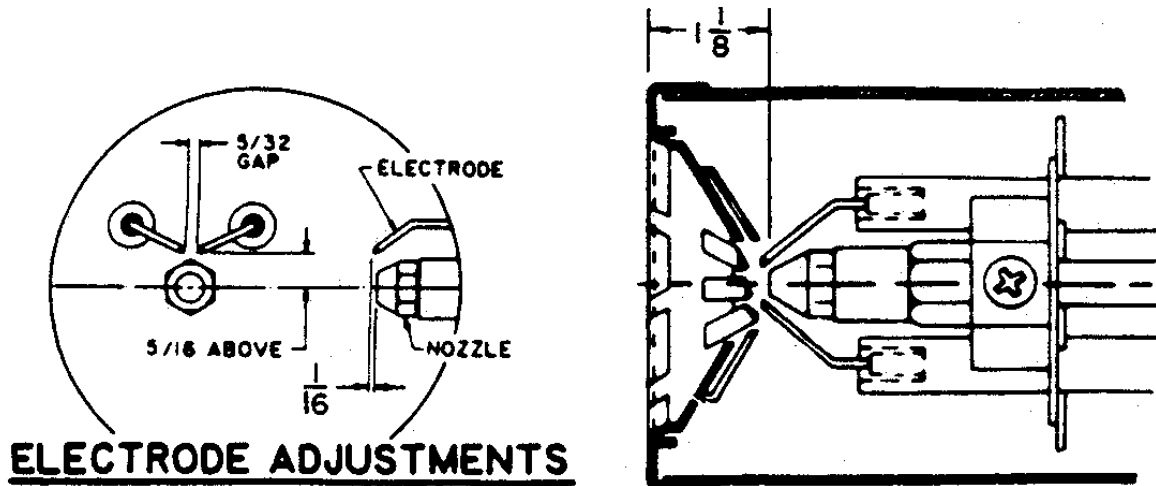

Figure 15: Electrode / Head Setting

- Remove the AIR TUBE COVER PLATE (5) by loosening the retaining SCREW (4) (Two SCREWS-Model F5).
 - Loosen SCREW (2), and then slide the complete drawer assembly out of the combustion head as shown.
- ii. Installation:
To insert drawer assembly, reverse the procedure in Step *i* above.
- b. **Nozzle Replacement**, refer to Figure 17.
- i. Remove the NOZZLE ADAPTER (2) from the DRAWER ASSEMBLY by loosening the SCREW (1).
 - ii. Remove existing nozzle from nozzle adapter.
 - iii. Insert the proper NOZZLE into NOZZLE ADAPTER and tighten securely (**DO NOT** cover tighten), refer to Table 7.
 - iv. Replace adapter, with nozzle installed, into drawer assembly and secure with screw (1).
- c. **Inspect and measure burner electrodes**. Refer to Figure 18 for the proper electrode settings.
- d. **Re-install Drawer Assembly into Combustion Head** per Step 3a above.
- e. **Insertion Depth**, verify the distance between the tip of the end cone is equal to the distance specified in Table 7.
- f. **Turbulator Setting**, refer to Figure 19 and Riello Burner Specifications Table 7.
- g. **Pump Connections and Port Identification**, refer to Figure 20.

This burner is shipped with the oil pump set to operate on a **single** line system. To operate on a **two-line** system the bypass plug must be installed.

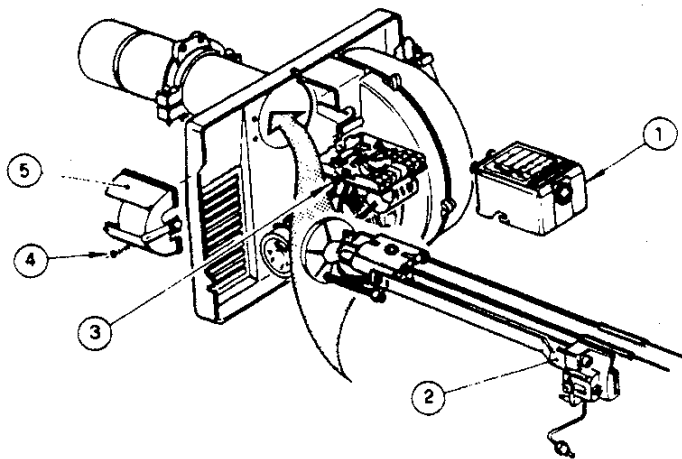

Figure 16: Installation/Removal of Riello Drawer Assembly

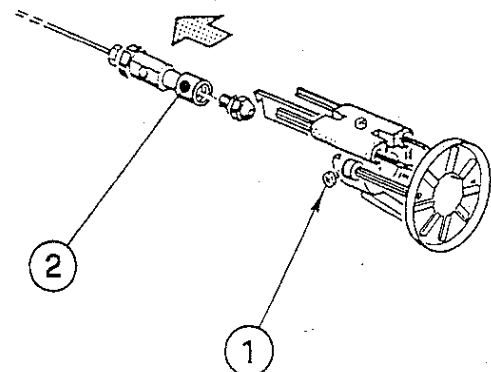

Figure 17: Riello Nozzle Replacement

VII: SYSTEM START-UP (continued)

WARNING: DO NOT operate a **single** line system with the by-pass plug installed.

Operating a **single** line system with the by-pass plug installed will result in damage to the pump shaft seal.

Note: Pump pressure was factory pre-set but must be checked at time of burner start-up. A pressure gauge is attached to the **PRESSURE/ BLEEDER PORT (7)** for pressure readings. Two **PIPE CONNECTORS (4)** are supplied with the burner for connection to either a single or two-line system. Also supplied are two

ADAPTORS (3), two female 1/4" NPT to adapt oil lines to burner pipe connectors. All pump port threads are **British Parallel Thread** design. Direct connection of NPT threads to the pump **will damage** the pump body.

Riello manometers and vacuum gauges **DO NOT** require any adapters, and can be safely connected to the pump ports. An NPT x metric adapter **must** be used when connecting other gauge models.

h. **Replace Burner Cover** and Tighten Burner Cover Screws.

IMPORTANT: THESE DIMENSIONS MUST BE OBSERVED AND VERIFIED.

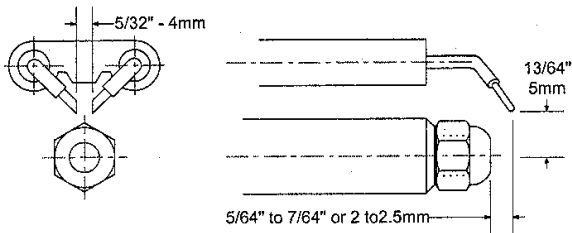

Figure 18: Riello Electrode Setting

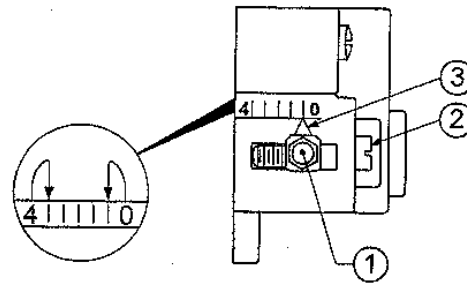

Figure 19: Riello Turbulator Setting

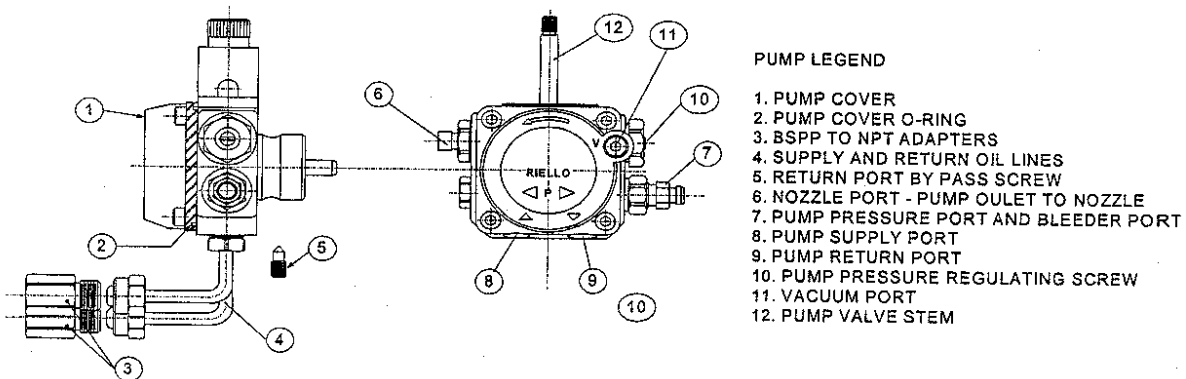

Figure 20: Riello Pump Connections and Port Identification

VII: SYSTEM START-UP (continued)

G. START OIL BURNER.

1. Open vent fitting on fuel pump.
2. TURN 'ON' BURNER service switch and allow burner to run until oil flows from vent fitting in a SOLID stream without air bubbles for approximately 10 seconds.
3. Close vent fitting and burner flame should start immediately after prepurge is completed. Prepurge prevents burner flame until 10 seconds has elapsed after initial power is applied to burner. During prepurge the motor and igniter will operate but the oil valve will remain closed. Refer to Oil Primary Control Instructions for more details.
4. Adjust oil pressure.
 - a. When checking a fuel unit's operating pressure, a reliable pressure gauge may be installed in either the bleeder port or the nozzle port. For Beckett burner refer to Figure 21. For Riello burner refer to Figure 20.
 - b. Locate oil pressure adjusting screw and turn screw to obtain proper pump pressure, refer to Tables 6 and 7.
 - c. To check the cutoff pressure, deadhead a reliable pressure gauge onto the copper connector tube attached to the nozzle port. Run the burner for a short period of time. Shut the burner off. The pressure should drop and hold.
 - d. Remove the gauge and install bleeder port and/or reconnect the nozzle port line.

WARNING

DO NOT loosen or remove any oil line fittings while burner is operating.

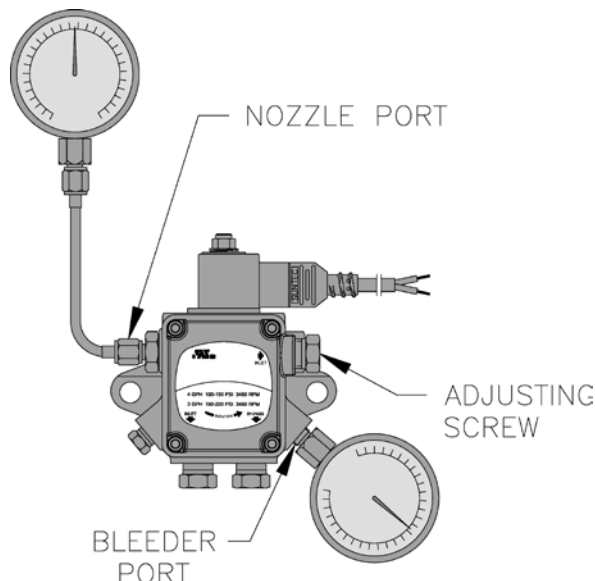

Figure 21: Adjusting Fuel Pump Pressure

H. ADJUST OIL BURNER WHILE OPERATING. (flame present)

1. SET ROOM THERMOSTAT about 10°F below room temperature.
2. PRESS RED RESET BUTTON on Oil Primary Control and release.
3. READJUST THE AIR DAMPER SETTING (air Band/Air Shutter/Air Gate) on the burner for a light orange colored flame while the draft over the fire is $-0.02''$. Use a smoke tester and adjust air for minimum smoke (not to exceed #1) with a minimum of excess air. Make final check using suitable instrumentation to obtain a CO_2 of 11.5 to 12.5% with draft of $-0.02''$ (water gauge) in fire box. These settings will assure a safe and efficient operating condition. If the flame appears stringy instead of a solid fire, try another nozzle of the same type. Flame should be solid and compact. After all adjustments are made, recheck for a draft of $-0.02''$ over the fire.
4. ADJUST DRAFT REGULATOR for a draft of $-0.02''$ (water gauge) over the fire after chimney has reached operating temperature and while burner is running.
5. **Riello Burners** - READJUST THE TURBULATOR SETTING only if necessary, refer to Table 7.
 - a. AP-490U through AP-790U (All Models)
Move the setting forward or back one position at a time to optimize the smoke and CO_2 readings. See Figure 19.
 - b. Steps outlined in Paragraph 3 above must be repeated every time the Head/Turbulator or Air Damper Setting is readjusted.
6. FLAME FAILURE
The AP-U boiler controls operate the burner automatically. If for unknown reasons the burner ceases to fire and the reset button on the primary control has tripped, the burner has experienced ignition failure. Refer to Oil Primary Control features, Paragraph J, Step 2 of this section and Section XI, Troubleshooting, Paragraph B. If the failure re-occurs, call your heating contractor immediately before pressing the reset button.

WARNING

DO NOT attempt to start the burner when excess oil has accumulated, when the boiler is full of vapor, or when the combustion chamber is very hot.

VII: SYSTEM START-UP (continued)

7. CAD CELL LOCATION AND SERVICE

The burner is supplied with a cadmium sulfide flame detector mounted at the factory, mounted on the bottom of the electronic ignitor. See Figure 22. To service cad cell or to replace the plug in portion, swing open the ignitor. After service is complete, be sure to fasten down the ignitor.

I. CHECK FOR CLEAN CUT OFF OF BURNER.

1. AIR IN THE OIL LINE between fuel unit and nozzle will compress when burner is on and will expand when burner stops, causing oil to squirt from nozzle at low pressure as burner slows down and causing nozzle to drip after burner stops. Usually

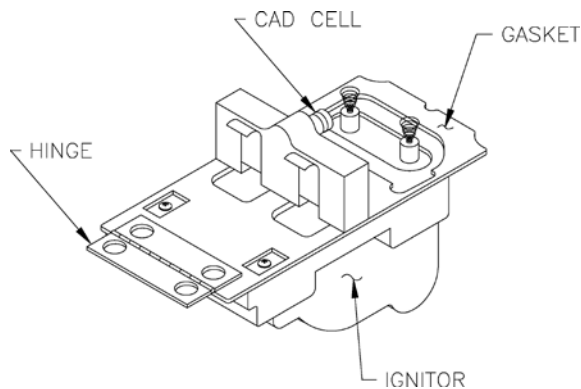

Figure 22: Cad Cell Location

cycling the burner operation about 5 to 10 times will rid oil line of this air.

2. IF NOZZLE CONTINUES TO DRIP, repeat Paragraph H, Step 1 above. If this does not stop the dripping, remove cut-off valve and seat, and wipe both with a clean cloth until clean, then replace and readjust oil pressure. If dripping or after burn persist replace fuel pump.

J. TEST CONTROLS

1. Check thermostat operation. Raise and lower thermostat setting as required to start and stop burner.

WARNING

Before installation of the boiler is considered complete, the operation of all boiler controls must be checked, particularly the primary control and high limit control.

2. VERIFY OIL PRIMARY CONTROL FEATURES using procedures outlined in Instructions furnished with control or instructions as follows:
 - a. **GeniSys 7505 Control Features**, see Figure 23
 - i. The GeniSys 7505 is a microprocessor-based control. The indicator light provides

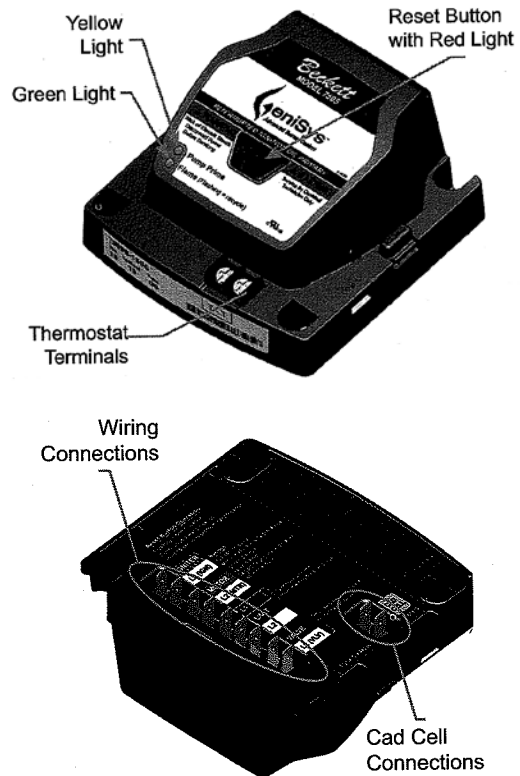

Figure 23: GeniSys 7505 Oil Primary Terminals, LED's and Reset Button

diagnostic information for lockout, recycling and cad cell status. There is a manual reset button to exit the Lockout Mode.

- ii. Pump Priming Cycle: To facilitate purging air from the oil lines and filters, the 7505 can be placed in a purge routine by:
 - After the burner starts, press and hold the reset button for 15 seconds until the yellow light turns on. This indicates that the button has been held long enough.
 - Release the reset button. The yellow light will turn off and the burner will start up again.
 - At burner start up, click the reset button while the igniter is still on. This will transition the control to a dedicated Pump Prime mode, during which the motor, igniter, and valve are powered for four (4) minutes. The yellow light will be on.
 - At the end of four (4) minutes, the yellow light will turn off and the control will automatically return to standby mode.
- iii. Limited Recycle: This feature limits the number of recycle trials (for each call for heat) to a maximum of three trials. If the flame is lost three times and does not

VII: SYSTEM START-UP (continued)

successfully satisfy a call for heat, the 7505 locks out.

- iv. Limited Reset (Restricted Mode): In order to limit the accumulation of unburned oil in the combustion area, the control can only be reset three times. The reset count returns to zero each time a call for heat is successfully completed.
- v. T-T Jumper: Select models have pre-installed T-T jumper. **DO NOT** remove jumper.

Note: **DO NOT** remove “T-T” jumper **unless** wiring diagram indicates a direct connection from thermostat and/or tankless heater aquastat control to the oil burner primary control’s “T-T” terminal. Refer to appropriate wiring diagram, see Figures 10 and 11.

- vi. Diagnostic LED: The indicator light on oil primary control provides lockout, recycle and cad cell indications as follows:
 - Flashing at 1 Hz (½ second on, ½ second off): system is locked out or in Restricted Mode.
 - Flashing at ¼ Hz (2 seconds on, 2 seconds off): control is in Recycle Mode.
 - On: cad cell is sensing flame.
 - Off: cad cell is not sensing flame.
- vii. Cad Cell Resistance Check: For proper operation it is important that the cad cell resistance is below 1600 ohms. During a normal call for heat, the cad cell leads can be unplugged from the control and the resistance measured with a meter in the conventional way. Conduct these tests with flame present, see chart below.

Flame Detection Range
Normal (0 - 1600 ohms)
Limited (1600 ohms to lockout)

3. CHECK OIL PRIMARY CONTROL

CAUTION

Due to the potential hazard of line voltage, only a trained, experienced service technician should perform the following safety checks.

This control contains no field-serviceable parts. DO NOT attempt to take it apart. Replace entire control if operation is not as described.

- a. Preliminary Steps
 - Check wiring connections and power supply.
 - Make sure power is on to the controls.
 - Make sure limit control is closed.
 - Check contacts between ignitor and the electrodes.
 - Check the oil pump pressure.
 - Check the piping to the oil tank.
 - Check the oil nozzle, oil supply and oil filter.
- b. Check Safety Features
 - Safe Start:
 - Place a jumper across cad cell terminals.
 - Follow procedure to turn on burner. Burner must not start, indicator light turns on and control remains in Idle Mode.
 - Remove jumper.
 - c. Simulate Ignition or Flame Failure:
 - Follow procedure to turn on burner.
 - Check cad cell resistance. If resistance is below 1600 OHMS and burner runs beyond safety cut-out time, cad cell is good.
 - If safety switch shuts down burner and resistance is above 1600 OHMS, open line switch to boiler. Access cad cell under ignitor, clean face of cad cell and see that cell is securely in socket. Check gasket around perimeter of ignitor lid for proper seal. If gasket is missing or damaged, replace gasket. Room light can effect cad cell resistance. Reset safety switch.
 - Close line switch to boiler. If burner starts and runs beyond safety switch cut-off time, cell is good. If not, install new cell.
 - Close hand valve in oil supply line.
 - Failure occurs, device enters Recycle Mode.
 - Device tries to restart system after approximately 60 seconds.
 - After third Recycle Mode trial, safety switch locks out within safety switch timing indicated on label and control enters Restricted Mode. Ignition and motor stop and oil valves closes.
- d. Power Failure Check: After Flame is established, turn the power off to the control/ burner. The burner should shut down safely. When power is restored a normal ignition sequence should be started.

VII: SYSTEM START-UP (continued)

WARNING

Cad Cell Jumper must be removed after this check.

4. CHECK HIGH LIMIT
 - a. Adjust system thermostat(s) to highest setting.
 - b. Allow burner to run until boiler water temperature exceeds high limit setting. The burner should shut down and circulators continue running.
 - c. Allow the temperature to drop below control setting. The burner must restart.
 - d. Boiler installation is not considered complete until this check has been made.
 5. CHECK OPERATING CONTROL on boiler applications equipped with tankless heater(s). With burner off, draw hot water until burner starts, then turn off hot water and check burner shut-down.
- K. IF CONTROLS MEET REQUIREMENT** outlined in Paragraph I.
1. Allow boiler to operate for approximately 30 minute, confirm the boiler and system have no leaks.
- L. IF CONTROLS DO NOT MEET REQUIREMENTS** outlined in Paragraphs I-1 thru I-6, replace control and repeat checkout procedures.
- M.** Boiler is now ready to be put into service.

VIII: OPERATING

A. WATER BOILERS SEQUENCE OF OPERATION

1. Water Boilers Without Tankless Heaters (Cold Start), Sequence Of Operation:

- a. The AP-U Boiler is equipped with an Intelligent Oil Boiler Control (Cold Start Boiler Control). The boiler control replaces the traditional electronic aquastat and circulator relays and adds energy saving thermal purge features. Energy is saved by starting the circulator and delaying the burner start when there is residual heat available in the boiler.
- b. The boiler's sequence of operation is shown as Status Codes on Boiler Control display. See Table 8 and Figure 24.
- c. When the thermostat calls for heat the boiler control starts the system circulator and the thermal purge (circulator pre-purge time) begins. If the time is completed or boiler temperature is less than the Start Temperature (140 F default) the start sequence continues by energizing the oil primary to operate the following sequence: blower is started and operates for pre-purge time; spark is energized and fuel valve is opened for ignition trial time; burner fires until the thermostat is satisfied.
- d. If the thermostat is not satisfied and the Operating Setpoint (SP) is reached the system circulator will continue to operate and the burner will stop. When the boiler water temperature drops below the setpoint less the differential setting the burner will restart.
- e. After the thermostat is satisfied the burner and circulator are stopped.
- f. When an indirect water heater aquastat call for heat is wired to the "ZR" terminal the Boiler Control starts a domestic hot water circulator connected to the "ZC" terminal and when the boiler temperature is less than Operating Setpoint (SP), the boiler control energizes the oil primary to turn on the burner without circulator pre-purge delay.

- g. On burner start, if the CAD cell does not see flame within approximately 15 seconds, primary control will shut down the burner and enter into a lockout mode. A lockout is reset by pressing the reset button located on the primary control. If the flame is lost while the burner is firing, the primary control shuts down the burner, enters a 60 second recycle delay, and repeats the ignition sequence. If after three (3) trials for ignition, flame is not detected, primary control will enter into restricted mode. Restricted mode is reset by holding down the reset button for 15 seconds.

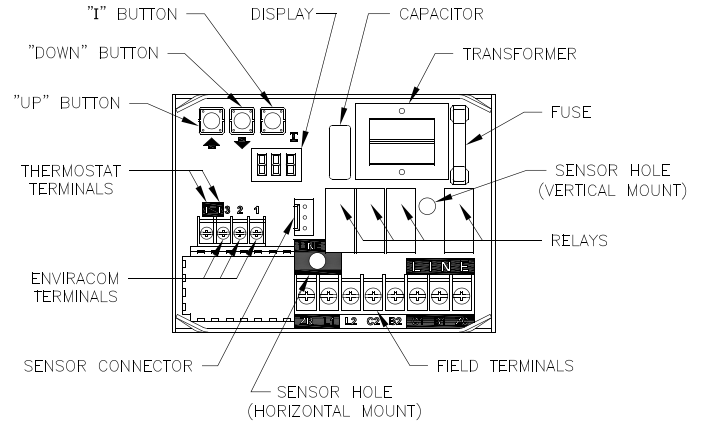

Figure 24: Intelligent Oil Boiler Control

2. Water Boilers with Tankless Heaters (Warm Start), Sequence Of Operation:

- a. The AP-U Boiler is equipped with a Warm Start Intelligent Oil Boiler Control (Warm Start Boiler Control). The Warm Start Boiler Control replaces the traditional high and low limit aquastat and circulator relays.
- b. The boiler's sequence of operation is shown as Status Codes on Boiler Control display. See Table 8 and Figure 24.
- c. When the thermostat calls for heat the boiler control starts the system circulator and the start sequence continues by energizing the oil primary to operate the following sequence: blower is started and operates for pre-purge time; spark is energized and fuel valve is opened for ignition trial time; burner fires until the thermostat is satisfied. Optionally, the thermal purge (circulator pre-purge time) maybe added adjusting the Circulator Pre-purge time parameter. This feature saves energy by starting the circulator and delaying the burner start when there is residual heat available in the boiler .

TABLE 8: SEQUENCE OF OPERATION

Status Codes Displayed in 5tR Mode		
5tR	Status	Description
1	Standby (burner off, pump off)	No call for heat detected
1	Standby (burner off, pump on)	Either condition is true: a. Call for heat detected and boiler temperature higher than operating setpoint. b. Call for heat detected and boiler temperature higher than 140 F and Pump Pre-Purge Time has not expired.
8	Running	The burner runs until the call for heat is satisfied.
17	Self Test	Control internal checking

VIII: OPERATING (continued)

- d. If the thermostat is not satisfied and the Operating Setpoint (SP) is reached the system circulator will continue to operate and the burner will stop. When the boiler water temperature drops below the setpoint less the differential setting the burner will restart.
- e. After the thermostat is satisfied the burner and circulator are stopped.
- f. The Warm Start Boiler Control also includes a low limit control function. When the boiler water temperature falls below the Low Limit Setpoint less the Low Limit Differential the "ZC" terminal and System Circulator outputs are de-energized and the oil primary is energized to start the burner. As temperature rises above the Low Limit Setpoint the burner is stopped, the "ZC" output is energized and the System Circulator is enabled to run in response to a call for heat.
- g. On burner start, if the CAD cell does not see flame within approximately 15 seconds, primary control will shut down the burner and enter into a lockout mode. A lockout is reset by pressing the reset button located on the primary control. If the flame is lost while the burner is firing, the primary control shuts down the burner, enters a 60 second recycle delay, and repeats the ignition sequence. If after three (3) trials for ignition, flame is not detected, primary control will enter into restricted mode. Restricted mode is reset by holding down the reset button for 15 seconds.

3. Using Boiler Control

The Boiler Control is located on front of boiler.

The Boiler Control display, along with Up ↑, Down ↓, and "I" keys may be used to view boiler operating status (Figure 25).

4. Viewing the Operating Mode Options

In operating mode the user may view (but not change) boiler operating status, settings and troubleshooting information. To view Boiler Control display information:

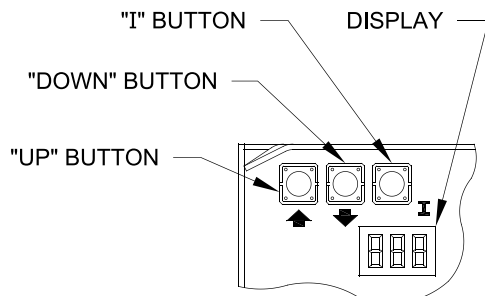
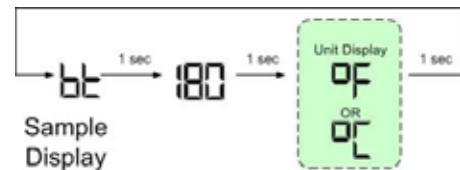

Figure 25: Boiler Control Key Function & Orientation

Press and release the "I" key on the Boiler Control to change from one parameter to the next. Each setting will alternately flash between the relevant display code and its corresponding value.

Operating Mode Options	
Status Numbers:	
5LR	1 Standby
	8 Running
	7 Self Test)
bL	Boiler Temperature
SP	Operating Setpoint (Outdoor Reset)
HL	High Limit Setting
HdF	High Limit Differential
LL	Low Limit Setpoint (warm start only)
LdF	Low Limit Differential (warm start only)
hr	Heat Request Status
dh	DHW Request Status
Err	Boiler Error

For example, when the "I" key is pressed on the Boiler Control until "bL" is displayed, it will then flash a three digit number (such as "180") followed by either "F" (or "L"). This indicates that the boiler water temperature is 180°F. Other operating parameters display the information in a similar fashion.



Please note that in operating mode to hold the display on the value the user can press and hold either the Up ↑ or Down ↓ keys and the value will be continuously shown. This may be helpful in watching a value "live".

5. Changing the Adjustable Parameters

To adjust parameters such as the High Limit Setpoint and High Limit Differential:

- a. Using the Boiler Control display, access the adjustment mode by pressing and holding the Up ↑, Down ↓, and "I" keys simultaneously for three (3) seconds. This procedure is intended to discourage unauthorized changes or accidental changes to limit settings.
- b. Press the "I" key to display available Adjustment Mode options. Select an option.

VIII: OPERATING (continued)

Cold Start Boiler Control Adjustment Mode Options		
<i>HL_</i>	140-240°F	Adjust High Limit Setting
<i>HdF</i>	10-30°F	Adjust High Limit Differential
<i>ZC_</i>	<i>dh</i> , <i>Zr</i> or <i>ELL</i>	ZC and ZR Terminal Function
<i>Or_</i>	0-10 minutes	Pump Overrun Time
<i>PP_</i>	2-20 minutes	Pump Pre-purge Time
<i>St_</i>	140 - 180°F	Start Temperature
<i>Pt_</i>	<i>On</i> or <i>OFF</i>	Priority Time
<i>F-C</i>	<i>F</i> or <i>C</i>	Select degrees F or C Mode
<i>bAc</i>		Back to Operating Mode

Warm Start Boiler Control Adjustment Mode Options		
<i>HL_</i>	140-240°F	Adjust High Limit Setting
<i>LL_</i>	110-220°F	Adjust Low Limit Setting
<i>LdF</i>	10-25°F	Adjust Low Limit Differential Setting
<i>ZC_</i>	<i>Zr</i> or <i>dh</i>	ZC and ZR Terminal Function
<i>Or_</i>	0-10 minutes	Pump Overrun Time
<i>PP_</i>	0-20 minutes	Pump Pre-purge Time
<i>St_</i>	140 - 180°F	Start Temperature
<i>Pt_</i>	<i>On</i> or <i>OFF</i>	Priority Time
<i>F-C</i>	<i>F</i> or <i>C</i>	Select degrees F or C Mode
<i>bAc</i>		Back to Operating Mode

- c. Press the Up \uparrow and Down \downarrow keys to adjust the displayed setpoint to the desired value.
- d. To return to the normal operating mode from the Adjustment Mode, when the “*bAc*” option is displayed, press either the Up \uparrow or Down \downarrow key. If no keys are pressed, after five (5) minutes the Boiler Control will automatically return to the Operating Mode.

6. More Information about Adjustable Parameters

- a. High Limit (*HL_*)
The Boiler Control is factory programmed with a High Limit Setpoint of 180°F. The boiler turns “off” when the boiler water temperature (*bT*) is above this value. The High Limit setpoint is adjustable between 140° and 240°F. The Operating Setpoint (*SP*) will equal the High Limit Setpoint.
- b. High Limit Differential (*HdF*)
 - i. The Cold Start Boiler Control is factory programmed with a Differential of 15°F. The Differential is the number of degrees the boiler temperature must decrease below the Operating Setpoint before the boiler can restart. The differential is adjustable between 10° and 30°F.
 - ii. On Warm Start Boiler Control the High Limit Differential is not adjustable and is fixed at 10°F.

c. Low Limit (*LL_*)

The Warm Start Boiler Control is factory programmed with a Low Limit Setpoint of 110°F. On falling temperature the boiler turns “on” and the “ZC” terminal and System Circulator outputs are de-energized when the boiler temperature is less than the Low Limit Setpoint less the differential. On a rising temperature when the boiler temperature is above the Low Limit Setpoint the boiler turns “off”, the “ZC” terminal output is energized and the System circulator is enabled to respond to a call for heat. The Low Limit Setpoint is adjustable between 110°F and 220°F.

d. Low Limit Differential (*LdF*)

The Warm Start Boiler Control is factory programmed with a Low Limit Differential Setpoint of 10°F. The Low Limit Differential is the number of degrees the boiler temperature must decrease below the Low Limit Setpoint before the Warm Start Boiler Control takes actions to warm the boiler. These actions include starting the burner and stopping water flow through the boiler. The Low Limit Differential is adjustable between 10°F and 25°F.

e. Circulator Overrun Time (*Or_*)

Circulator Overrun Time (also called “circulator off delay” or “circulator post purge”) continues circulator operation after a call for heat has ended, sending excess heat from the boiler into the priority zone. Ensure system piping and zone panel settings allow water flow to the priority zone after the call for heat ends. The Circulator Overrun Time has a factor setting of 0 minutes and is field adjustable between 0 and 10 minutes.

f. Circulator Pre-Purge Time (*PP_*)

When the boiler is warm [boiler water temperature higher than 140°F (adjustable using Start Temperature parameter)] and there is a thermostat call for heat, the system circulator is started and boiler firing is delayed pre-purge minutes. If the temperature drops below 140°F or there is a DHW Call for Heat the boiler is started without delay. Additionally, the boiler is started without delay if the thermostat call for heat is initiated when the boiler water temperature is less than 140°F. This feature helps save energy by satisfying home heating needs with residual boiler heat rather than cycling the boiler. The Circulator Pre-purge time has a factory setting of 2 minutes and is field adjustable between 2 and 20 minutes. Refer to Table 9.

The Warm Start Boiler Control Pre-purge Time is factor set to 0 minutes.

VIII: OPERATING (continued)

TABLE 9: CIRCULATOR PRE-PURGE TIME EXAMPLE, PARAMETER PP_ = 2 MINUTES

Call for Heat	ZC and ZR Terminal Function (ZC_)	Boiler Temp.	Boiler Status, (B1 Output)
TT= on	--	< 140	Start with no delay
TT = on	--	>140	Start after 2 minute delay
ZR = on	ZC_ = Zr	<140	Start with no delay
ZR = on	ZC_ = Zr	>140	Start after 2 minute delay
ZR = on	ZC_ = dH	<140	Start with no delay
ZR = on	ZC_ = dH	>140	Start with no delay

g. Start Temperature (St_)

The amount of “Heat available” is calculated by taking the difference between measured boiler water temperature and the Start Temperature setting. Useful “Heat Available” is dependent on the type of heating emitter installed in the home. Heat emitters require a certain minimum temperature to operate effectively. Our default settings reflect cast iron radiators. Fan Coils may require a start temperature setting of 180°F or 160°F before providing heat to the home. The Start Temperature has a factory setting of 140°F and is field adjustable between 140°F and 180°F.

h. Priority Time (Pt_)

When the Priority Time parameter is set to “on” and Domestic Hot Water (DHW) call for heat is “on” the DHW demand will take “Priority” over home heating demand and the system circulator will be forced “off”. Priority Time ends and the system circulator is released to service home heating demand when Domestic Hot Water call for heat is over. When Priority Time parameter is set to “Off” the DHW call for heat does not force “off” the system circulator. The Priority Time has a factory setting of “On” and is field adjustable between “On” and “Off” Refer to Table 10.

TABLE 10: DOMESTIC HOT WATER DEMAND, (PARAMETER ZC_ = dH)

Call for Heat		Priority Time (Pt_)	Circulator Status	
T-T Input	ZR Input		System Circulator Output	DHW Circulator ZC Output
on	off	On	on	off
on	on	On	off	on
off	on	On	off	on
on	off	OFF	on	off
on	on	OFF	on	on
off	on	OFF	off	on

i. ZC and ZR Terminal Function (ZC_)

The boiler control allows configuration of the ZC output functionality to help the AP-U integrate into each installation more effectively. The ZC output can be connected to a domestic hot water circulator or a second heating zone circulator or be used to enable pumps in a warm start application. These applications are selected as follows:

i. When ZC_ is set equal to Domestic Hot Water Demand (dH)

When there is an Indirect Water Heater (IWH) the boiler control provides a “ZR” input terminal for the IWH Aquastat and “ZC” output terminal for the DHW Circulator. When there is a DHW call for heat, the System Circulator is “forced off”, the DHW Circulator terminal is energized and the circulator pre-purge time delay control logic is bypassed to allow the boiler to fire without delay. When DHW demand ends the System Circulator “force off” is removed, the circulator can respond normally, and the DHW Circulator is de-energized. The DHW call for heat is detected by a voltage on to the “ZR” terminal. When a Priority Time parameter is set to “off” the System Circulator is not forced off for a DHW call for heat. Refer to Table 10.

VIII: OPERATING (continued)

TABLE 11: ZONE REQUEST, PARAMETER $\mathcal{ZC}_- = \mathcal{Zr}$

Call for Heat		Circulator Status	
T-T Input	ZR Input	C1 Output	ZC Output
off	off	off	off
on	off	on	off
on	on	on	on
off	on	off	on

- ii.* When \mathcal{ZC}_- is set equal to Zone Request (\mathcal{Zr})
 When there is no IWH the Cold Start Boiler Control “ZC” output may be configured to control a second heating zone. This is particularly helpful when the home uses only two heating zones. The boiler control replaces the need for a two circulator zone panel. When DHW Terminal Function (\mathcal{dh}_-) is set to \mathcal{Zr} the boiler control’s two circulator outputs are used to control two independent heating zones. Refer to Table 11. A “TT” input causes a call for heat and energizes the System Circulator output to service heating zone 1. A second zone’s thermostat may be wired to the “ZR” input to energize heating zone 2 circulator wired to the “ZC” output. Both outputs function independently, “TT” input controls only the System Circulator output and the “ZR” input controls only the “ZC” output. Both inputs cause a boiler call for heat.

TABLE 12: EXTERNAL LOW LIMIT, PARAMETER $\mathcal{ZC}_- = \mathcal{ELL}$

Call for Heat		Circulator Status	
T-T Input	ZR Input	C1 Output	ZC Output
off	off	off	on
on	off	on	on
on	on	off	off
off	on	off	off

The Warm Start Boiler Control with \mathcal{ZC}_- set equal to Zone Request (\mathcal{Zr}) energizes the “ZC” terminal while the boiler is warm as described earlier in this section (refer to Paragraph A,2,f). The “ZR” input is a call for heat that starts the boiler.

- iii.* External Low Limit, Parameter $\mathcal{ZC}_- = \mathcal{ELL}$
 The Cold Start Boiler Control is capable of functioning as a warm start control when external limit control is installed that closes a contact when boiler water temperature falls below a setpoint. When an external limit contact closes (boiler water is cold) the boiler is started and the “ZC” and “C1” output terminals are de-energized. When the “ZR” terminal is de-energized (boiler water temperature is above setpoint) the call for heat is ended and the “C1” terminal is released to operation and the “ZC” terminal is energized. An External Low Limit Request is detected by sensing a voltage on the “ZR” terminal. The Warm Start Boiler Control does not have the External Low Limit Option. Refer to Table 12.

IX: MAINTENANCE & SERVICE INSTRUCTIONS

A. WATER BOILERS:

1. Filling of boiler and system.

GENERAL — In a hot water heating system, the boiler and entire system (other than the expansion tank) must be full of water for satisfactory operation. Water should be added to the system until the boiler pressure gauge registers 12 psi. To insure that the system is full, water should come out of all air vents when opened.

2. **BOILING OUT OF BOILER AND SYSTEM.** The oil and grease which accumulate in a new hot water boiler can be washed out in the following manner:
 - a. Remove relief valve using extreme care to avoid damaging it.
 - b. Add an appropriate amount of recommended boil out compound.
 - c. Replace relief valve.
 - d. Fill the entire system with water.
 - e. Start firing the boiler.
 - f. Circulate the water through the entire system.
 - g. Vent the system, including the radiation.
 - h. Allow boiler water to reach operating temperature, if possible.
 - i. Continue to circulate the water for a few hours.
 - j. Stop firing the boiler.
 - k. Drain the system in a manner and to a location that hot water can be discharged with safety.
 - l. Remove plugs from all available returns and wash the water side of the boiler as thoroughly as possible, using a high-pressure water stream.
 - m. Refill the system with fresh water.

3. Add appropriate boiler water treatment compounds as recommended by your qualified water treatment company.

4. Make pH or Alkalinity Test.

After boiler and system have been cleaned and refilled as previously described, test the pH of the water in the system. This can easily be done by drawing a small sample of boiler water and testing with hydrion paper which is used in the same manner as litmus paper, except it gives specific readings. A color chart on the side of the small hydrion dispenser gives the reading pH. Hydrion paper is inexpensive and obtainable from any chemical supply house or through your local druggist. The pH should be higher than 7 but lower than 11. Add some of the washout chemical (caustic soda), if necessary, to bring the pH within the specified range.

5. Boiler is now ready to be put into service.

B. EXCESSIVE MAKE-UP WATER

A leaky system will increase the volume of make-up water supplied to the boiler, which can significantly shorten the life of the boiler. Entrained in make-up water are dissolved minerals, salts and oxygen. When the fresh, cool make-up water is heated in the boiler, the minerals fall out as sediment, the salts coat the inside of the boiler, and the oxygen escapes as a gas. The accumulation of sediment eventually isolates the water from contacting the steel. When this happens the steel in that area gets extremely hot and eventually cracks. The presence of free oxygen or chloride salts in the boiler creates a corrosive atmosphere which, if the concentration becomes high enough, can corrode the steel through from the inside. More make-up water and higher concentrations of contaminants damage the boiler sooner. **Our warranty does not cover corrosion and sediment-related damage.** Clearly it is in everyone's best interest to prevent this type of failure. You can do your part by ensuring that your system is leak-free, keeping leakage to less than 2 percent of the total water volume each month. Refer to Chart below.

IMPORTANT

IF, DURING NORMAL OPERATION, IT IS NECESSARY TO ADD MORE WATER THAN INDICATED BELOW, CONSULT A QUALIFIED SERVICE TECHNICIAN TO CHECK YOUR SYSTEM FOR LEAKS.

Model No.	Gallons Per Month	Gallons Per Year
AP-490U	0.2	3
AP-590U	0.2	3
AP-690U	0.3	4
AP-790U	0.3	4

C. ATTENTION TO BOILER WHILE NOT IN OPERATION

1. IMPORTANT

IF BOILER IS NOT USED DURING WINTER TIME, IT MUST BE FULLY DRAINED TO PREVENT FREEZE DAMAGE.

2. Spray inside surfaces with light lubricating or crankcase oil using gun with extended stem so as to reach all corners.
3. With steam boilers, at end of season add sufficient water to fill boiler to top of water column and leave it that way until fall when water should be drained again to proper level. If, at this time, boiler water is dirty, drain water, flush out boiler, and refill with clean water to prescribed water level.

IX: MAINTENANCE & SERVICE INSTRUCTIONS (continued)

4. Always keep the manual fuel supply valve shut off if the burner is shut down for an extended period of time.
5. To recondition the heating system in the fall season after a prolonged shut down, follow the instructions outlined in Section VII, System Start-Up, Paragraphs A through M.

WARNING

This boiler contains controls which may cause the boiler to shut down and not restart without service. If damage due to frozen pipes is a possibility, the heating system should not be left unattended in cold weather; or appropriate safeguards and alarms should be installed on the heating system to prevent damage if the boiler is inoperative.

X: BOILER CLEANING

NOTICE

BURNER SHUTDOWN: Open Service Switch to turn off burner.

Manual Oil Supply Valve should be closed and Electric Service to boiler turned off if boiler will not be operated for an extended period of time.

A. GENERAL. Inspection service and cleaning should be conducted annually. Turn off electric power and close oil supply valve while conducting service or maintenance.

B. FIRETUBES AND COMBUSTION CHAMBER. (See Figure 26)

NOTE: UNITS SHOULD BE CLEANED AT LEAST ONCE A YEAR, PREFERABLY AT THE END OF EACH HEATING SEASON.

IT IS NOT NECESSARY TO REMOVE BURNER TO CLEAN BOILER.

BRUSH, SCRAPE OR VACUUM CLEAN FLUE TUBES CAREFULLY FROM TOP WITHOUT EXTENDING CLEANING TOOLS BEYOND BOTTOM OF FLUE TUBES TO PREVENT DAMAGE TO COMBUSTION CHAMBER.

CAUTION

COMBUSTION CHAMBER IS A LIGHTWEIGHT CERAMIC TYPE. **DO NOT** EXTEND CLEANING TOOLS BEYOND BOTTOM OF FLUE TUBES TO PREVENT DAMAGE TO COMBUSTION CHAMBER.

BOILER MODEL	DIMENSION 'X'
AP-490U & AP-590U	13 $\frac{3}{8}$
AP-690U & AP-790U	19 $\frac{1}{8}$

1. CLEAN THE FIRETUBES
 - a. Disconnect electric to burner and remove stack.
 - b. For access to the firetubes, pull top jacket panel off. Remove brass nuts, that hold canopy down. Without taking off carriage bolts, pull canopy off.
 - c. Remove turbulators.
 - d. Using a firetube brush clean firetubes. **DO NOT** extend brush past the end of the bottom tubesheet.
 - e. Assemble the boiler in reverse order.

Units should be cleaned at least once a year, preferably at the end of each heating season.

It is not necessary to remove burner to clean boiler.

Brush, scrape, or vacuum from **top**.

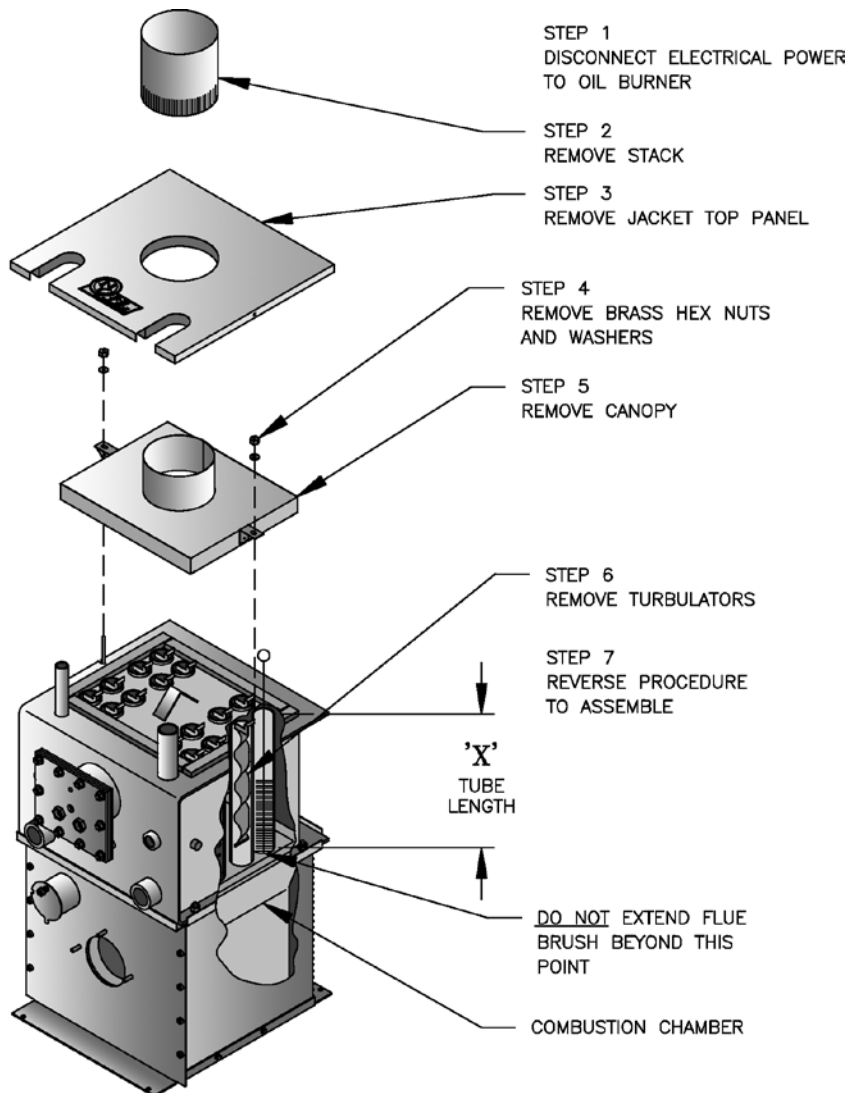

CLEANING INSTRUCTIONS

Figure 26: Cleaning of AP-U Boiler

Important Product Safety Information **Refractory Ceramic Fiber Product**

Warning:

The Repair Parts list designates parts that contain refractory ceramic fibers (RCF). RCF has been classified as a possible human carcinogen. When exposed to temperatures about 1805°F, such as during direct flame contact, RCF changes into crystalline silica, a known carcinogen. When disturbed as a result of servicing or repair, these substances become airborne and, if inhaled, may be hazardous to your health.

AVOID Breathing Fiber Particulates and Dust

Precautionary Measures:

Do not remove or replace RCF parts or attempt any service or repair work involving RCF without wearing the following protective gear:

1. A National Institute for Occupational Safety and Health (NIOSH) approved respirator
 2. Long sleeved, loose fitting clothing
 3. Gloves
 4. Eye Protection
- Take steps to assure adequate ventilation.
 - Wash all exposed body areas gently with soap and water after contact.
 - Wash work clothes separately from other laundry and rinse washing machine after use to avoid contaminating other clothes.
 - Discard used RCF components by sealing in an airtight plastic bag. RCF and crystalline silica are not classified as hazardous wastes in the United States and Canada.

First Aid Procedures:

- If contact with eyes: Flush with water for at least 15 minutes. Seek immediate medical attention if irritation persists.
- If contact with skin: Wash affected area gently with soap and water. Seek immediate medical attention if irritation persists.
- If breathing difficulty develops: Leave the area and move to a location with clean fresh air. Seek immediate medical attention if breathing difficulties persist.
- Ingestion: Do not induce vomiting. Drink plenty of water. Seek immediate medical attention.

XI: TROUBLESHOOTING

A. COMBUSTION

1. **NOZZLES** — Although the nozzle is a relatively inexpensive device, its function is critical to the successful operation of the oil burner. The selection of the nozzle supplied with the AP-U boiler is the result of extensive testing to obtain the best flame shape and efficient combustion. Other brands of the same spray angle and spray pattern may be used but may not perform at the expected level of CO₂ and smoke. Nozzles are delicate and should be protected from dirt and abuse. Nozzles are mass-produced and can vary from sample to sample. For all of those reasons a spare nozzle is a desirable item for a serviceman to have.
2. **FUEL LEAKS** — Any fuel leak between the pump and the nozzle will be detrimental to good combustion results. Look for wet surfaces in the air tube, under the ignitor, and around the air inlet. Any such leaks should be repaired as they may cause erratic burning of the fuel and in the extreme case may become a fire hazard.
3. **SUCTION LINE LEAKS** — Any such leaks should be repaired, as they may cause erratic burning of the fuel and in extreme cases may become a fire hazard. Whatever it takes, **The Oil Must Be Free of Air.** This can be a tough problem, but it must be resolved. Try bleeding the pump through a clear tube. There must be no froth visible. There are various test kits available to enable you to look at the oil through clear tubing adapted to the supply line at the pump fitting. Air eliminators are on the market that have potential. Also, electronic sight glasses are being used with good success. At times, new tubing must be run to the tank or new fittings put on. Just make sure you get the air out before you leave.

Any air leaks in the fuel line will cause an unstable flame and may cause delayed ignition noises. Use only flare fittings in the fuel lines.
4. **GASKET LEAKS** — If 11.5 to 12.5% CO₂ with a #1 smoke cannot be obtained in the breeching, look for air leaks around the burner mounting gasket, observation door, and canopy gasket. Such air leaks will cause a lower CO₂ reading in the breeching. The smaller the firing rate the greater effect an air leak can have on CO₂ readings.
5. **DIRT** — A fuel filter is a good investment. Accidental accumulation of dirt in the fuel system can clog the nozzle or nozzle strainer and produce a poor spray pattern from the nozzle. The smaller the firing rate, the smaller the slots become in the nozzle and the more prone to plugging it becomes with the same amount of dirt.

6. **WATER** — Water in the fuel in large amounts will stall the fuel pump. Water in the fuel in smaller amounts will cause excessive wear on the pump, but more importantly water doesn't burn. It chills the flame and causes smoke and unburned fuel to pass out of the combustion chamber and clog the flueways of the boiler.
7. **COLD OIL** — If the oil temperature approaching the fuel pump is 40°F or lower, poor combustion or delayed ignition may result. Cold oil is harder to atomize at the nozzle. Thus, the spray droplets get larger and the flame shape gets longer. An outside fuel tank that is above grade or has fuel lines in a shallow bury is a good candidate for cold oil. The best solution is to locate the tank near the boiler in the basement utility room or bury the tank and lines deep enough to keep the oil above 40°F. Check environmental issues with local authorities having jurisdiction.
8. **FLAME SHAPE** — Looking into the combustion chamber through the observation port, the flame should appear straight with no sparklers rolling up toward the crown of the chamber. If the flame drags to the right or left, sends sparklers upward or makes wet spots on the target wall, the nozzle should be replaced. If the condition persists look for fuel leaks, air leaks, water or dirt in the fuel as described above.
9. **HIGH ALTITUDE INSTALLATIONS** — Air openings must be increased at higher altitudes. Use instruments and set for 11.5 to 12.5% CO₂.
10. **START-UP NOISE** — Late ignition is the cause of start-up noises. If it occurs recheck for electrode settings, flame shape, air or water in the fuel lines.
11. **SHUT DOWN NOISE** — If the flame runs out of air before it runs out of fuel, an after burn with noise may occur. That may be the result of a faulty cut-off valve in the fuel pump, or it may be air trapped in the nozzle line. It may take several firing cycles for that air to be fully vented through the nozzle. Water in the fuel or poor flame shape can also cause shut down noises.

NOTICE

CHECK TEST PROCEDURE. A very good test for isolating fuel side problems is to disconnect the fuel system and with a 24" length of tubing, fire out of an auxiliary five gallon pail of clean, fresh, warm #2 oil from another source. If the burner runs successfully when drawing out of the auxiliary pail then the problem is isolated to the fuel or fuel lines being used on the jobsite.

XI: TROUBLESHOOTING (continued)

B. OIL PRIMARY CONTROL (Oil Primary)

1. Burner (Oil Primary) will not come on.
 - a. No power to Oil Primary.
 - b. Oil Primary is in lockout or restricted mode. Press reset button for one (1) second to exit lockout. If control has recycled three times within the same call for heat, it will enter into restricted mode. To reset from restricted mode, refer to Section VII, Paragraph I, Step 2 for details.
 - c. CAD cell seeing light.
 - d. CAD assembly defective.
 - e. Control motor relay is stuck closed (see note below).
2. Burner (control) will light, then shut down after a short time, then restart after one (1) minute.
 - a. CAD cell is defective.
 - b. Air leaking into oil line causing flame out.
 - c. Defective nozzle causing flame to be erratic.
 - d. Excessive airflow or draft causing flame to leave burner head.
 - e. Excessive back pressure causing flame to be erratic.
3. Control locks out after Trial For Ignition (TFI).
 - a. No oil to burner.
 - b. Shorted electrodes.
 - c. Nozzle clogged.
 - d. Airflow too high.
 - e. Ignitor module defective.

- f. CAD cell defective.
- g. Oil valve stuck open or closed.

Note: The Safety Monitoring Circuit (SMC) is designed to provide lockout in the event of a stuck or welded motor relay.

NOTICE

If flame is not established within 15 seconds of oil valve actuation (known as Trial For Ignition [TFI]) lockout will occur. Lockout is indicated by a red LED solid-on located on the oil primary control.

Hard Lockout will occur if the Oil Primary Control locks-out three (3) times during a call for heat. This is indicated by red light reset button solid-on.

C. INTELLIGENT OIL BOILER CONTROL

- **Cold Start Boiler Control** is used on Boilers without Tankless Heaters.
 - **Warm Start Boiler Control** is used on Boilers with Tankless Heaters
1. When a problem occurs with the boiler operation, the Boiler Control easily provides specific, valuable information to help resolve the issue quickly. The display on the Boiler Control should be the first place to check.
 - a. If an Error Code “Err” IS NOT displayed on the Boiler Control: In this circumstance, Table 13 can be used to determine the problem and possible causes.

TABLE 13: TROUBLESHOOTING GUIDE

System Condition	Diagnostic Condition	Check	Action
Boiler is cold, house is cold.	Display is OFF.	120 Vac System power.	Turn system power on.
	Display is ON.	24 Vac T-T	No 24 V; replace control.
		24 V present; disconnect thermostat, short T-T.	Boiler starts, check wiring and thermostat.
		120 Vac at B1-B2	<ul style="list-style-type: none"> • If no, replace control. • If yes, check burner and wiring.
	Refer to Err on display.	-----	
Boiler is hot, house is cold.	Display is ON.	120 Vac at C1-C2	<ul style="list-style-type: none"> • 120 Vac at C1-C2, check wiring to pump. • Wiring OK, is pump running? • If not, replace the pump. • If pump is running, check for trapped air or closed zone valves
		Boiler below the Low Limit temperature, wait for boiler to go above Low Limit temperature.	-----
		Boiler above LL? If yes, check for 120 Vac between ZC and L2.	<ul style="list-style-type: none"> • If no 120 Vac, replace control. • If yes, check zone relays, circulators and wiring.

XI: TROUBLESHOOTING (continued)

- b. If the Boiler Control detects an error it will flash "Err" (boiler control error) followed by a number. Use this text and number to identify the boiler problem and corrective action in Table 14 below.

TABLE 14: BOILER CONTROL ERROR NUMBERS

Display	Status	Recommended Corrective Actions
Err 1	Temperature Sensor Fault	Temperature sensor failure, wire harness loose or shorted connection or control hardware failure: <ul style="list-style-type: none"> - Check sensor is securely attached to boiler control - Check that sensor wire is not damaged - If secure and in good condition, replace sensor - If problem persists, replace control
Err 2	Communication Fault	EnviraCom terminal is shorted to ground or line voltage. <ul style="list-style-type: none"> - Check wiring to EnviraCOM terminals 1,2 and 3. Wiring to external EnviraCom device is incorrect.
Err 3	Internal Hardware Fault	Error detected with AC power supply frequency or boiler control failure. Cycle power to the control. Replace control if problem persists.
Err 4	Burner Output (B1) Fault	B1 output sensed powered during safety output relay check sequence or un-powered during running, or powered in idle in combination with water temperature above 264°F limit. Cycle power to the control. Replace control if problem persists.
Err 5	Line Voltage Fault (< 80 Vac)	AC voltage out of specification high or low; check L1, L2, 110 VAC.
Err 6	Fuse missing	Internal fuse is blown or missing. The fuse protects the Aquastat from miss wiring the L1 and L2 on Oil Primary. When the Oil Primary is correctly wired the fuse is useless and not detected. If Primary is wired incorrectly the fuse is blown out and Aquastat report error 6. EnviraCOM message is sent when the wiring is fixed and the error disappears to indicate the end of the error state. Check wiring and replace fuse.
Err 7	User settings lost, (reset to factory defaults)	Warning: Generated if user adjustments are lost and the device uses factory default values. Error is cleared by entering and exiting the Adjustment mode. Replace control if problem persists.
Err 8	Manual Reset Lockout (resettable)	Set if Err 4 was invoked four times in a row. Check wiring and clear Lockout by pressing all three user keys for 30 seconds.

XII: REPAIR PARTS

All AP-U™ Series Repair Parts may be obtained through your local New Yorker Wholesale distributor. Should you require assistance in locating a New Yorker distributor in your area, or have questions regarding the availability of New Yorker products or repair parts, please contact: New Yorker Boiler Co., Inc., P.O. Box 10, Hatfield, PA 19440-0010, Phone: (215) 855-8055 or Fax: (215) 855-8229, ATTN: Customer Service Department.

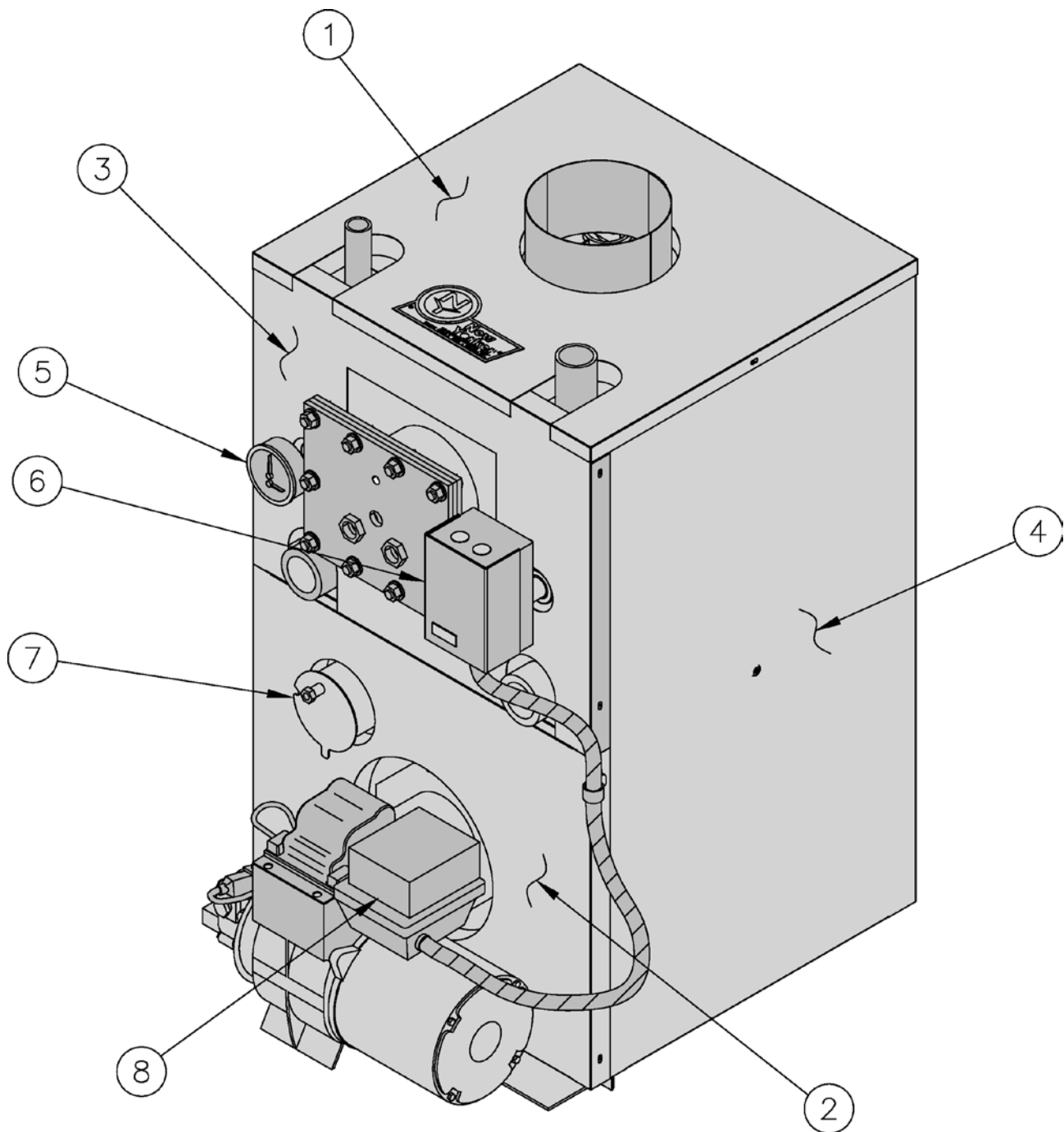

Figure 27: AP-U Boiler Jacket Parts and Controls

XII: REPAIR PARTS (continued)

AP-U SERIES BOILER REPAIR PARTS

ITEM	DESCRIPTION	PART NUMBER	QTY.
1	Jacket Top Panel Assembly	6047104	1
2	Jacket Lower Front Panel Assembly	60471042	1
3	Jacket Upper Front Panel Assembly - 490U / 590U	60471041	1
	Jacket Upper Front Panel Assembly - 690U / 790U	60471061	1
4	Jacket Wrap-a-Round Panel Assembly - 490U / 590U	60471043	1
	Jacket Wrap-a-Round Panel Assembly - 690U / 790U	60471063	1
5	Temperature / Pressure Gauge	100282-01	1
6	Cold Start Intelligent Oil Boiler Control, Honeywell L7248L1090	103850-01	1
	Warm Start Intelligent Oil Boiler Control, Honeywell L7224A1030	103853-01	1
7	Observation Port Cover	7026001	1
	Observation Cover Spring V1	8026015	1
	Flat Washer, SAE, 5/16"	80860647	1
	Hex Nut, 5/16 -18, Heavy	80860402	1
8	Burner Primary Control, GeniSys 7505	103447-01	1

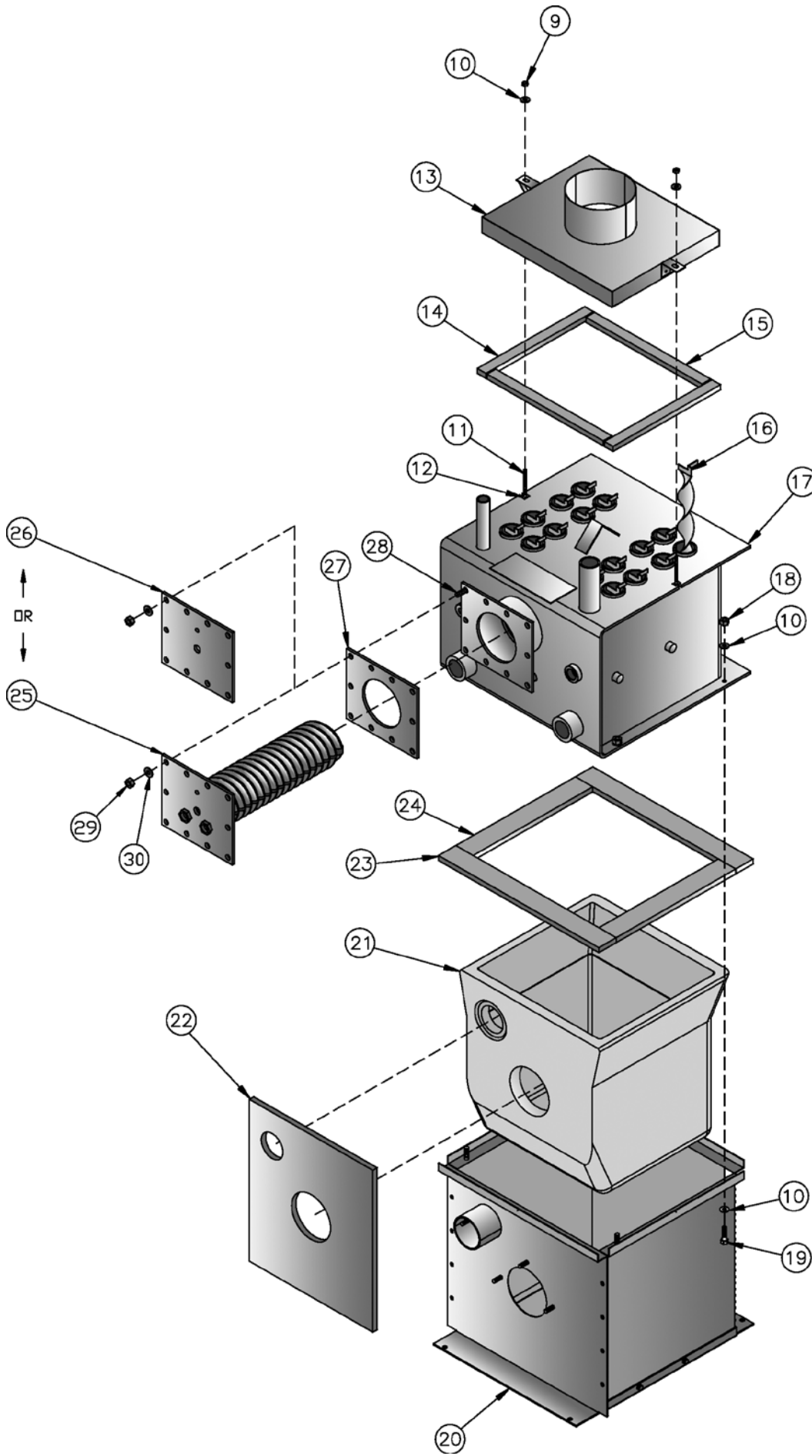

Figure 28: AP-490U thru 790U Bare Boiler Repair Parts

NOTE: When ordering parts always give the serial number and model number shown on the boiler. Also provide the name of the part(s) shown below:

XII: REPAIR PARTS (continued)

AP-U SERIES BOILER REPAIR PARTS (continued)

ITEM NO.	DESCRIPTION	PART NO.	QTY.
9	Hex Nut, 1/4 - 20, Brass	80860119	2
10	Flat Washer, SAE 1/4	80860424	10
11	C-bolt, 1/4 - 20 x 3	80860847	2
12	1/4" Threaded Stud Push Retainer	80861725	2
13	Canopy Assembly	6113509	1
14	Cerafelt Strip 1/2" x 1 x 12-3/8"	9206005	5 Lineal Feet (Total)
15	Cerafelt Strip 1/2 x 1 x 13-3/8"		
16	Turbulator, Short	7116037	'A' See Table Below
	Turbulator, Long	7116038	'B' See Table Below
17	Shell Assembly	'C' See Table Below	1
18	Hex Lock Nut 1/4 - 20	80860456	4
19	Machine Screw 1/4 - 20 x 1-1/4"	80860810	4
20	Base Assembly	61835062	1
21	Combustion Chamber	8203006	1
22	Base Front Insulation	8203512	1
23	Cerafelt, 1/2" Thick x 2" x 18-1/2"	9206003	6 Lineal Feet (Total)
24	Cerafelt, 1/2" Thick x 2" x 13-3/4"		
25	S-5 Heater Coil Assembly	6037202	1
26	Blanket Heater Cover Plate	7033715	1
27	Gasket, Blanket Heater Cover Plate	8206036	1
28	SA-307B 3/8 x 1-1/4" Hex Head Bolt	80861360	10
29	Heavy Hex Nut, 3/8 - 16	80860400	10
30	Flat Washer USS, 3/8"	80860645	10

BOILER MODEL	QTY 'A'	QTY 'B'	PART NO. 'C'
AP-490U	12	---	63071100
AP-590U	16	---	63071101
AP-690U	---	12	63071102
AP-790U	---	16	63071103

XIII: BECKETT AFG BURNER PARTS FOR AP-U SERIES BOILERS

FOR REPLACEMENT OIL BURNER PARTS, CONTACT YOUR WHOLESALER OR THE BURNER MANUFACTURER:

R. W. BECKETT CORP.
P. O. BOX 1289
ELYRIA, OHIO 44036
1-800-645-2876

NOTE: When ordering parts always give the serial and model numbers shown on the boiler and burner. Also, provide the name of the part(s) and part(s) number as listed below.

Boiler Model	AP-490U	AP-590U	AP-690U	AP-790U
Burner Model	AFG	AFG	AFG	AFG
Air Tube Combination	AF40WR	AF40BZ	AF40WB	AF40BZ
Spec. No.	NY2101	NY2103	NY2105	NY2108
AFG Housing	5874BK	5874BK	5874BK	5874BK
Air Band	3492BKA	3492BKA	3492BKA	3492BKA
Air Band Nut	4150	4150	4150	4150
Air Band Screw	4198	4198	4198	4198
Air Shutter	3709	3709	3709	3709
Air Shutter Screw	4198	4198	4198	4198
Blower Wheel	2999U	2999U	2999U	2999U
Bulkhead Fitting	571801	571801	571801	571801
Bulkhead Fitting Locknut	3666	3666	3666	3666
Connector Tube Assembly	5636	5636	5636	5636
Coupling	2454	2454	2454	2454
Electrode Clamp	149	149	149	149
Electrode Clamp Screw	4219	4219	4219	4219
Electrode Insulator Assembly	5780	5780	5780	5780
Spider Spacer Assembly	5653	5653	5653	5653
Escutcheon Plate	3493	3493	3493	3493
Flange and Air Tube Assembly	3146806	3146806	3146806	3146806
Gasket	3811	3811	3811	3811
Head	360003	360004	360004	360004
Head Screws	4221	4221	4221	4221
Hole Plug	2139	2139	2139	2139
Housing Assembly w/Inlet Bell	5877	5877	5877	5877
Motor	21805U	21805U	21805U	21805U
Nozzle Adapter	213U	213U	213U	213U
Nozzle Line Electrode Assembly	NL40WR	NL40BZ	NL40WB	NL40BZ
Pump	21844	21844	21844	21844
Static Plate	3898	31646	3898	31646
Ignitor	51771U	51771U	51771U	51771U
Ignitor Hinge Screw	4217	4217	4217	4217
Ignitor Holding Screw	4198	4198	4198	4198
Ignitor Gasket Kit	51304	51304	51304	51304
Wire Guard	3345	3345	3345	3345
Junction box	5770	5770	5770	5770
Flame Detector	7006Q	7006Q	7006Q	7006Q
Baffle	5880	---	---	---

XIII: BECKETT AFG BURNER PARTS FOR AP-U SERIES BOILERS (continued)

Ordering Information for Quality Replacement Parts

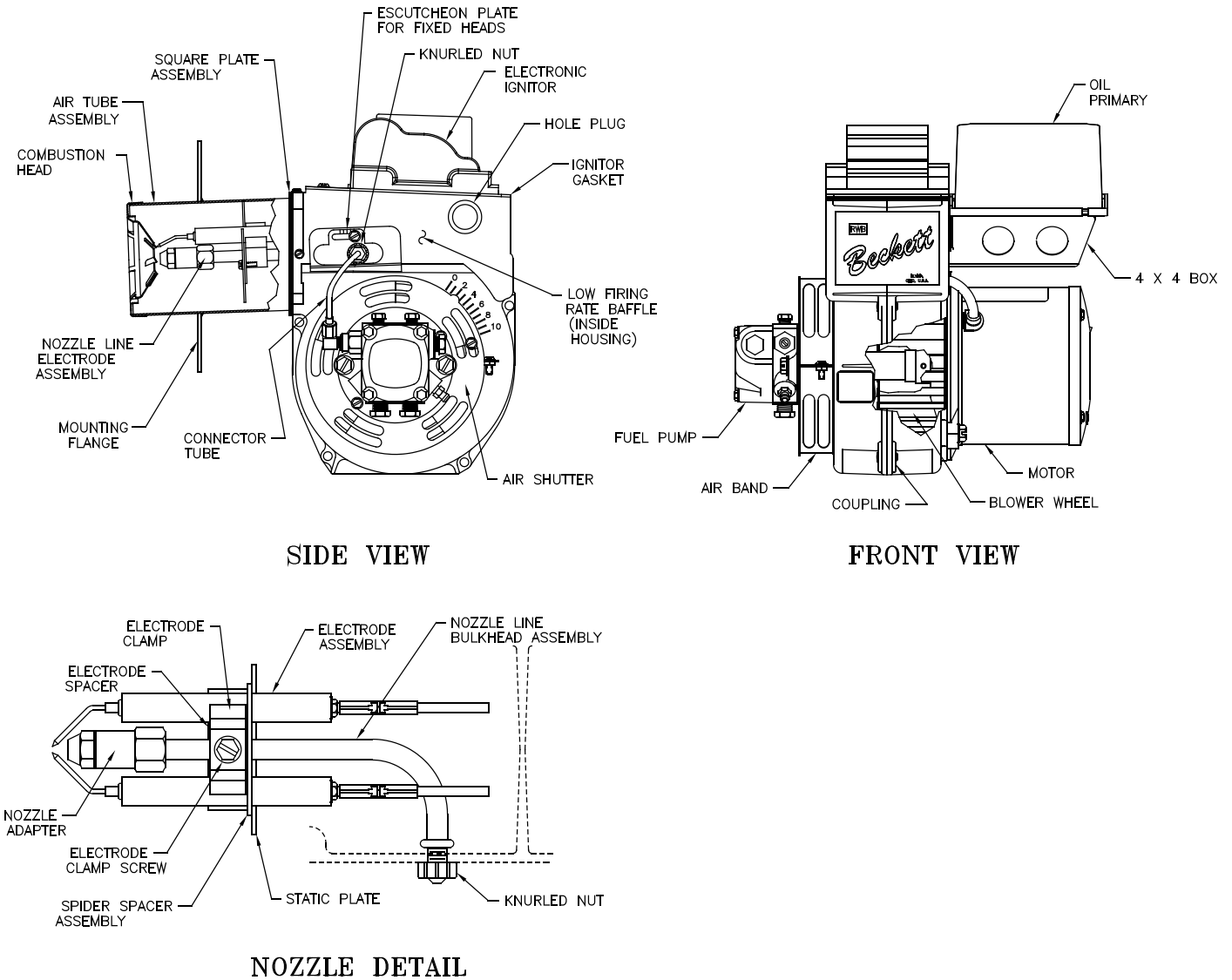

Figure 29: BECKETT AFG MODEL BURNER (Fixed 'F' Head)

XIV: RIELLO 40 SERIES BURNER PARTS FOR AP-U SERIES BOILERS

NOTE: When ordering parts always give the serial and model numbers shown on the boiler and burner.

Refer to *Models F3 & F5 Installation Manual, Riello 40 Series Residential Oil Burners (C6501010)* for an exploded view of the burner and a list of spare parts.

For replacement Riello oil burner parts, contact your wholesaler or the burner manufacturer:

Riello Corporation of America
35 Pond Park Road
Hingham, Massachusetts 02043
Telephone: (617) 749-8292
Facsimile: (617) 740-2069
Toll Free: (outside Massachusetts)
(800) 992-7637

Riello Canada Inc.
2165 Meadowpine Blvd.
Mississauga, Ontario L5N 6H6
Telephone: (905) 542-0303
Facsimile: (905) 542-1525
Toll Free: (800) 387-3898

APPENDIX A: LOW WATER CUT OFF (LWCO) ON HOT WATER BOILERS

WARNING

DO NOT ATTEMPT to cut factory wires to install an aftermarket Low Water Cut Off (LWCO). Only use connections specifically identified for Low Water Cut Off.

In all cases, follow the Low Water Cut Off (LWCO) manufacturer's instructions.

When

A low water cutoff is required to protect a hot water boiler when any connected heat distributor (radiation) is installed below the top of the hot water boiler (i.e. baseboard on the same floor level as the boiler). In addition, some jurisdictions require the use of a LWCO with a hot water boiler.

Where

The universal location for a LWCO on both gas and oil hot water boilers is above the boiler, in either the supply or return piping. The minimum safe water level of a water boiler is at the uppermost top of the boiler; that is, it must be full of water to operate safely.

It is recommended that the LWCO control is installed above the boiler to provide the highest level of protection. However, where the LWCO control is approved by the LWCO control manufacturer for installation in a high boiler tapping of a water boiler, the use of the listed LWCO control is permitted when it is installed according to the LWCO manufacturer's instructions.

What Kind

Typically, in residential applications, a probe type LWCO is used instead of a float type, due to their relative costs and the simplicity of piping for a probe LWCO.

How to Pipe

A "tee" is commonly used to connect the probe LWCO to the supply or return piping, as shown below.

Select the appropriate size tee using the LWCO manufacturer's instructions. Often, the branch

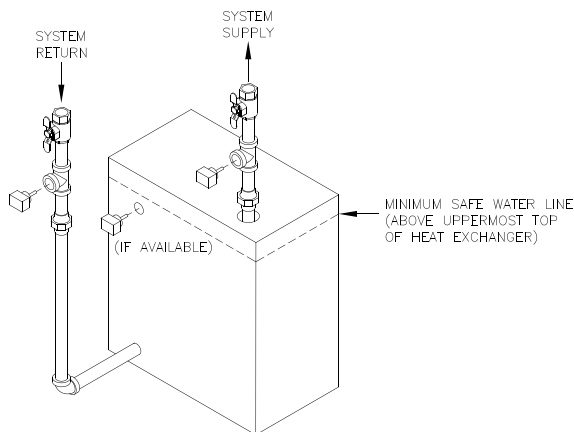

LWCO Location

connection must have a **minimum** diameter to prevent bridging between the probe and the tee. Also, the run of the tee must have a minimum diameter to prevent the end of the probe from touching or being located too close to the inside wall of the run of the tee. Ideally, manual shutoff valves should be located above the LWCO and the boiler to allow for servicing. This will allow probe removal for inspection without draining the heating system. Many probe LWCO manufacturers recommend an annual inspection of the probe.

How to Wire

LWCO's are available in either 120 VAC or 24 VAC configurations. The 120 VAC configuration can be universally applied to both gas and oil boilers by wiring it in the line voltage service to the boiler (after the service switch, if so equipped).

The presence of water in a properly installed LWCO will cause the normally open contact of the LWCO to close, thus providing continuity of the 120 VAC service to the boiler.

It is recommended to supply power to the probe LWCO with the same line voltage boiler service as shown below.

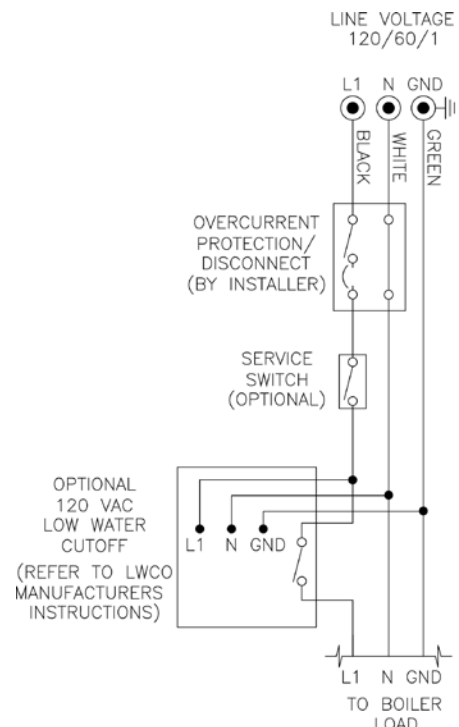

Wiring of Typical LWCO

APPENDIX A: LOW WATER CUT OFF (LWCO) ON HOT WATER BOILERS (continued)

A 24 VAC LWCO is used primarily for gas fired boilers where a 24 volt control circuit exists within the boiler. However, a 24 VAC LWCO can only be used if the boiler manufacturer has provided piping and wiring connections and instructions to allow for this application.

How to Test

Shut off fuel supply. Lower water level until water level is BELOW the LWCO. Generate a boiler demand by turning up thermostat. Boiler should not attempt to operate. Increase the water level by filling the system. The boiler should attempt to operate once the water level is above the LWCO.

NEW YORKER BOILER CO., INC.

Limited Warranties

For Residential Cast Iron and Steel Boilers

By this Warranty Statement New Yorker Boiler Co., Inc. ("New Yorker"), issues limited warranties subject to the terms and conditions stated below. These limited warranties apply to residential cast iron and steel water boilers labeled with the New Yorker® brand which are sold on or after March 1, 2004.

ONE YEAR LIMITED WARRANTY

One Year Limited Warranty for Residential Water Boilers New Yorker warrants to the original consumer purchaser at the original installation address that its residential cast iron and steel water boilers will be free from defects in material and workmanship under normal usage for a period of one year from the date of original installation. In the event that any defect in material or workmanship is found during the one year period following the date of installation, New Yorker will, at its option, repair the defective part or provide a replacement free of charge, F.O.B. its factory.

WC BOILER FIVE YEAR LIMITED WARRANTY

Five Year Pressure Vessel Limited Warranty for WC™ Residential Water Boilers New Yorker warrants to the original consumer purchaser at the original installation address that the pressure vessel of the boiler will be free of defects in material and workmanship under normal usage for a period of five years following the date of installation. In the event that any defect in material or workmanship is found during the five year period following the date of installation, New Yorker will, at its option, repair the defective pressure vessel or provide a replacement free of charge, F.O.B. its factory.

LIFETIME LIMITED WARRANTY

For all gas/oil-fired residential boilers, New Yorker warrants to the original consumer purchaser at the original installation address that the heat exchanger of the boiler will be free of defects in material and workmanship under normal usage for the lifetime of the original consumer purchaser. In the event that any defect in material or workmanship is found during the ten year period following the date of installation, New Yorker will, at its option, repair the defective pressure vessel or provide a replacement free of charge, F.O.B. its factory. In the event that any defect in material or workmanship is found after the tenth year following the date of installation, New Yorker will provide a replacement pressure vessel upon payment by the original consumer purchaser of an amount equal to a percentage of the then current retail price of the model boiler involved (or, in the event that such model is not then in production, the most comparable model then in production), as follows:

		Service Charge as a % of Retail Price																							
Years in Service		1-5	6	7	8	9	10	11	12	13	14	15	16	17	18	19	20	21	22	23	24	25+			
WC Boilers	N/C	100																							
Water Boilers	No Charge	5	10	15	20	25	30	35	40	45	50	55	60	65	70	75									
Steam Boilers	No Charge	100																							

EXCEPTIONS AND EXCLUSIONS

- Components Manufactured by Others** - following the expiration of the foregoing one year limited warranty, all component parts of a boiler which are manufactured by others (such as burners, burner controls, circulator, tankless water heater, and New Yorker Link) shall be subject only to the manufacturer's warranty, if any.
- Removal and Replacement Costs** - these warranties do not cover expenses of removal or reinstallation. The consumer purchaser will be responsible for the cost of removing and replacing any defective part and all labor and related materials connected therewith. Replacement parts will be invoiced to the distributor in the usual manner and will be subject to adjustment upon proof of defect.
- Proper Installation** - these warranties are conditioned upon the installation of the boiler in strict compliance with New Yorker's Installation, Operating and Service Instructions. New Yorker specifically disclaims any liability of any kind which arises from or relates to improper installation.
- Improper Use or Maintenance** - these warranties will not be applicable if the boiler is used or operated over its rated capacity, is installed for uses other than home heating, or is not maintained in accordance with New Yorker's Installation, Operating and Service Instructions and hydronics industry standards.
- Improper Operation** - these warranties will not be applicable if the boiler has been damaged as a result of being improperly serviced or operated, including but not limited to the following:

operated with insufficient water; allowed to freeze; subjected to flood conditions; or operated with water conditions and/or fuels or additives which cause unusual deposits or corrosion or on the pressure vessel or associated controls.

- Geographic Limitations** - these warranties apply only to boilers installed within the 48 contiguous United States.
- Installation Requirements** - in order for these warranties to be effective:
 - The boiler must be installed in a single or two-family residential dwelling. This warranty does not apply to boilers installed in apartments for commercial or industrial applications.
 - The boiler must be installed in strict compliance with New Yorker's Installation, Operating and Service Instructions by an installer regularly engaged in boiler installations.
 - Boiler sections must not have been damaged during shipment or installation.
 - The boiler must be vented in accordance with chimney recommendations set forth in New Yorker's Installation, Operating and Service Instructions.
- Exclusive Remedy** - New Yorker's obligation in the event of any breach of these warranties is expressly limited to the repair or replacement of any part found to be defective under conditions of normal use.
- Limitation of Damages Under no circumstances will New Yorker be liable for incidental, indirect, special or consequential damages of any kind under these warranties, including, without limitation, injury or damage to persons or property and damages for loss of use, inconvenience or loss of time.** New Yorker's liability under these warranties shall under no circumstances exceed the purchase price paid for the boiler involved. Some states do not allow the exclusion or limitation of incidental or consequential damages, so the above limitation or exclusion may not apply to you.
- Limitation of Warranty** - these limited warranties are given in lieu of all other express warranties and set forth the entire obligation of New Yorker with respect to any defect in a residential water boiler. New Yorker shall have no express obligations, responsibilities or liabilities of any kind, other than those set forth herein.

ALL APPLICABLE IMPLIED WARRANTIES, IF ANY, INCLUDING ANY WARRANTY OF MERCHANT ABILITY OR FITNESS FOR A PARTICULAR PURPOSE, ARE EXPRESSLY LIMITED DURATION TO A PERIOD OF ONE YEAR, EXCEPT THAT IMPLIED WARRANTIES, IF ANY, APPLICABLE TO THE PRESSURE VESSEL OF A RESIDENTIAL WATER BOILER SHALL BE LIMITED IN DURATION TO THE LESSER OF THE DURATION OF SUCH IMPLIED WARRANTY OR A PERIOD EQUAL TO THE TERM OF THE APPLICABLE EXPRESS WARRANTY

Some states do not allow limitations on how long an implied warranty lasts, so the above limitation may not apply to you.

PROCEDURE FOR OBTAINING WARRANTY SERVICE

Upon discovery of a condition believed to be related to a defect in material or workmanship covered by these warranties, the original consumer purchaser should notify the installer, who will in turn notify the distributor. If this action is not possible or does not produce a prompt response, the original consumer purchaser should write to New Yorker Boiler Co., Inc. at P.O. Box 10, Hatfield, PA 19440-0010, giving full particulars in support of the claim.

The original consumer purchaser is required to make available for inspection by New Yorker or its representatives the parts claimed to be defective and, if requested by New Yorker, to ship those parts prepaid to New Yorker at the above address for inspection or repair. In addition, the original consumer purchaser agrees to make all reasonable efforts to settle any disagreement arising in connection with any warranty claim before resorting to legal remedies in the courts.

THIS WARRANTY GIVES YOU SPECIFIC LEGAL RIGHTS AND YOU MAY ALSO HAVE OTHER RIGHTS WHICH VARY FROM STATE TO STATE.



New Yorker
RESIDENTIAL HEATING BOILERS