

july 2009
6

*idronics*TM

JOURNAL OF DESIGN INNOVATION FOR HYDRONIC PROFESSIONALS

SOLAR THERMAL COMBISYSTEMS



G CALEFFI

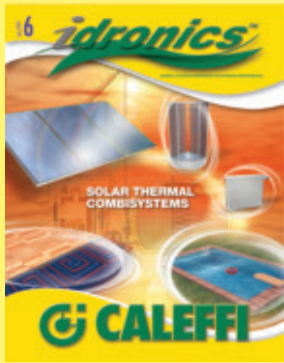

A Technical Journal
from
Caleffi Hydronic Solutions

CALEFFI NORTH AMERICA, INC
3883 W. Milwaukee Rd
Milwaukee, Wisconsin 53208 USA

Tel: 414-238-2360
FAX: 414-238-2366

E-mail: idronics@caleffi.com
Website: www.caleffi.us

To receive future idronics issues
FREE, register online www.caleffi.us



Caleffi North America, Inc.
3883 W. Milwaukee Rd
Milwaukee, Wisconsin 53208
T: 414.238.2360 F: 414.238.2366

Dear Hydronic Professional,

Welcome to the 6th edition of idronics, Caleffi's semi-annual design journal for hydronic professionals.

The global recession has slowed nearly all industries over the past year. However, despite declines in construction, solar water heater shipments in the US increased 50% during 2008.

As more and more HVAC professionals become familiar with solar water heating, many recognize opportunities to extend solar thermal technology for combined domestic hot water and space heating applications. This is a trend our parent Caleffi SpA identified several years ago in Europe, and is now a topic of growing interest here in North America. For this reason, solar "combisystems" was selected as the topic for this edition of idronics.

Caleffi is pleased to provide the information in this edition to assist those designing solar combisystems. We also stand ready with state-of-the-art hardware to support installation of such systems.

We encourage you to send us feedback on this edition of idronics by e-mailing us at idronics@caleffi.com.

Finally, if you are interested in previous editions of idronics, please go to www.caleffi.us where they can be freely downloaded. You can also register to receive future issues online.

Sincerely,

Mark Olson
General Manager,
Caleffi North America, Inc.

INDEX

3 INTRODUCTION

3 FUNDAMENTALS OF SOLAR COMBISYSTEM DESIGN

Essential Design Principles
Instantaneous Collector Efficiency
Freeze Protection

6 SPACE HEATING OPTIONS

Heated Floor Slabs
Heated Thin-Slabs
Other Site-Built Radiant Panels
Panel Radiators
Forced-Air Distribution Systems

13 ANTIFREEZE-BASED SOLAR COMBISYSTEMS

Advantages of Antifreeze-Based Systems
Disadvantage of Antifreeze-Based Systems
Heat Dump Provisions
Antifreeze-Based Combisystem Designs
Antifreeze-Based Combisystem #1
Antifreeze-Based Combisystem #2
Antifreeze-Based Combisystem #3
Antifreeze-Based Combisystem #4
Antifreeze-Based Combisystem #5
Using a Pool as a Heat Dump

23 DRAINBACK SOLAR COMBISYSTEMS

Advantages of Drainback Systems
Disadvantages of Drainback Systems
Open-Loop vs. Closed-Loop Drainback Systems
Operation of a Drainback System
Siphon Limitations
Sight Glasses
Tank Piping Connections
Drainback Combisystem #1
Drainback Combisystem #2
Drainback Combisystem #3
Drainback Combisystem #4

40 PERFORMANCE EXPECTATIONS

Estimations
f-chart Analysis
Case Studies
Collector Orientation in Combisystems
Storage Tank Size in Combisystems

44 SUMMARY

45 APPENDIX A: Piping Symbol Legend
46 APPENDIX B: Heat Exchanger Performance
48 APPENDIX C: Tank and Piping Volume Formulas
49 APPENDIX D: Unit Conversion Factors

Product Information Pages



© Copyright 2009
Caleffi North America, Inc.
Printed: Milwaukee, Wisconsin USA

SOLAR THERMAL COMBISYSTEMS

1. INTRODUCTION

Most Americans are increasingly aware of rising energy prices and the environmental implications associated with continued use of conventional fuels. “Sustainable living” is one of the most prevalent topics being discussed in a variety of media.

This situation has created growing interest in renewable sources, such as sun, wind and biomass materials. It is also fostering a rapidly expanding market for equipment that harvests this energy.

Hydronics technology is the “glue” that holds most thermally based renewable energy systems together. Although heat sources such as solar collectors, solid-fuel boilers and geothermal heat pumps are indispensable components in such systems, they are not the sole determinants of efficiency, energy yield or financial viability. Without proper heat conveyance, even the best renewable energy heat source will not perform as expected. Thus, the proper application of modern hydronics technology is vital to the continued growth of the thermally based renewable energy systems market.

This issue of *idronics* focuses on systems that use solar energy, as well as an auxiliary energy source, to supply a portion of the domestic hot water and space heating needs of a building. Such configurations are commonly called solar thermal combisystems. Several design variations will be introduced and discussed in the context of residential and light commercial building applications. In each case, state-of-the-art hydronic technology such as variable flow, manifold-based distribution, hydraulic separation, thermal mass and precisely controlled zoning are used to enhance the system’s energy efficiency, enabling it to deliver the same unsurpassed comfort, reliability and long life as that provided by a well-designed conventional hydronic system.

Both piping and control aspects of solar combisystems are illustrated and described. In many cases, the control techniques are similar to those used in modern “non-solar” hydronic systems. When properly applied, these techniques allow combisystems to smoothly transition between use of solar and auxiliary energy so that occupants experience no difference in comfort.

The energy savings potential of such systems will also be discussed. The goal is for designers to develop reasonable expectations for what typical solar thermal combisystems can provide based on differences in climate, system size and loads.

2. FUNDAMENTALS OF SOLAR COMBISYSTEM DESIGN

The largest sector of the solar thermal market is domestic water heating. This is true both in North America and worldwide. The underlying reason is the capacity to use solar energy on a year-round basis, and in particular, the ability to collect solar energy when it is most abundant — in summer. Solar thermal systems for heating domestic water were discussed in detail in *idronics* #3 (January 2008).

A natural extension of a solar domestic water heating system is adding capability to offset a portion of the space heating load in the same building, and hence the name “combisystem.”

Most combisystems intended for residential applications treat domestic water heating as the primary load, and thus take advantage of high solar energy availability in summer. Beyond their DHW “base load,” combisystems typically use greater collector area and larger storage tanks to capture and contain additional energy that can offset a portion of the building’s space heating load.

As with solar DHW systems, combisystems require a reliable means of freeze protection, as well as an auxiliary energy device that supplies the energy required for uninterrupted delivery of hot water and space heating when solar heat gains cannot cover the load.

ESSENTIAL DESIGN PRINCIPLES:

The following design concepts are imperative to the success of a solar combisystem. Each will be discussed in the context of specific system designs described later in this issue.

- The cooler the solar collectors can operate, the higher their efficiency, and the greater the amount of solar energy they harvest.

- In an “ideal” solar thermal system, none of the heat produced by the auxiliary heat source would enter the solar storage tank. This prevents the auxiliary heat source from increasing the temperature of the storage tank above what it would be based solely on solar energy input. Such heating, if allowed to occur, delays the startup of the solar collection cycle, and thus reduces the energy collected during that cycle.

Some “single tank” combisystems discussed in this issue do not adhere to this principle. However, they all rely on temperature stratification to direct heat added by the auxiliary heat source to the upper portion of the storage tank. This minimizes heating of the lower portion of the tank, and thus reduces interference with the solar collection control process.

- The collector array and any piping outside of the heated space must be protected against freezing.
- Almost every solar combisystem gathers more energy on a sunny summer day than can be used by the load (which is typically just domestic water heating). All solar combisystems must have a means of dealing with this surplus energy so it doesn’t damage the system.

INSTANTANEOUS COLLECTOR EFFICIENCY:

The performance of any solar combisystem is implicitly linked to the performance of its solar collector array. The best solar combisystems are designed to enhance collector efficiency. Doing so requires a fundamental knowledge of what collector efficiency is and how it is affected by operating conditions imposed by the balance of the system.

The instantaneous thermal efficiency of a solar collector is defined as the ratio of the heat transferred to the fluid passing through the collector divided by the solar radiation incident on the gross area of the collector, as shown in figure 2-1.

Instantaneous collector efficiency can be measured by recording the flow rate through the collector along with simultaneous measurement of the collector’s inlet and outlet temperature. The intensity of the solar radiation striking the collector must also be measured. Formula 2-1 can then be used to calculate the instantaneous thermal efficiency of the collector.

Formula 2-1:

$$\eta_{collector} = \frac{(8.01 \times c \times D) \times f \times (T_{out} - T_{in})}{I \times A_{gross}}$$

Where:

- c = specific heat of fluid (Btu/lb/°F)
- D = density of fluid (lb/ft³)
- f = flow rate (gallons per minute)
- T_{in} = collector inlet temperature (°F)
- T_{out} = collector outlet temperature (°F)
- I = instantaneous solar radiation intensity (Btu/hr/ft²)
- A_{gross} = gross collector area (ft²)
- 8.01 = a unit conversion factor

The phrase *instantaneous collector efficiency* can vary from moment to moment depending on the operating conditions. Do not assume that a given set of operating conditions is “average” or “typical,” and thus could be used to determine the collector’s efficiency over a longer period of time.

Instantaneous collector efficiency is very dependent on the fluid temperature entering the collector, as well as the temperature surrounding it. It also depends on the intensity of the solar radiation incident upon the collector. This relationship is shown in figure 2-2 for a typical flat plate and evacuated tube collector.

The thermal efficiency of each collector is plotted against the inlet fluid parameter. This parameter combines the effects of inlet fluid temperature, ambient air temperature and solar radiation intensity into a single number.

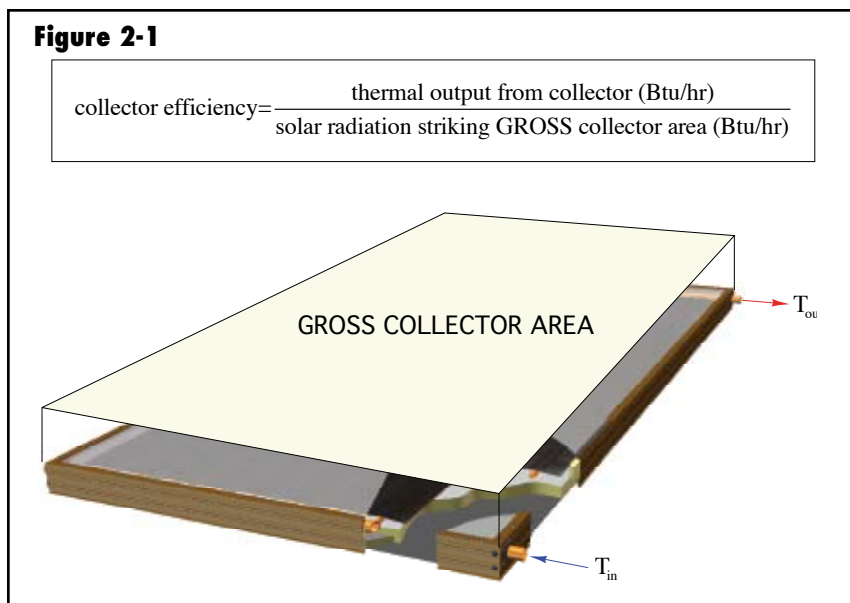
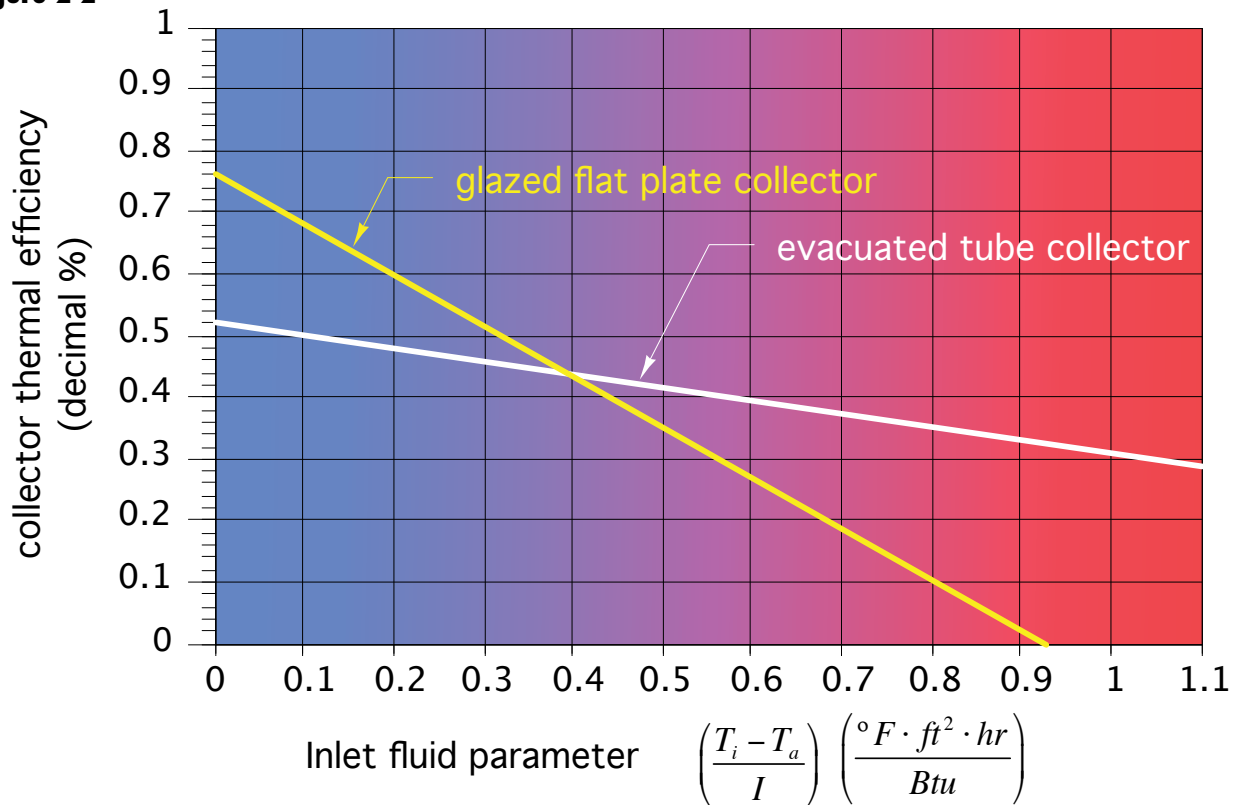

Figure 2-2



For a given solar radiation intensity and outdoor air temperature, any operating condition that increases the fluid temperature entering the collector causes the inlet fluid parameter to increase. This causes a drop in thermal efficiency for both the flat plate and evacuated tube collectors. Conversely, any operating condition that lowers the inlet fluid temperature also lowers the inlet fluid parameter and increases collector efficiency.

Systems that can operate with relatively low collector inlet temperatures generally allow flat plate collectors to reach thermal efficiencies higher than those attained by evacuated tube collectors. Conversely, systems that require the collector to operate at higher temperatures are usually better suited to evacuated tube collectors. Design tools such as simulation software can be used to determine which type of collector allows a given combisystem to harvest the greatest amount of solar energy.

The value of the inlet fluid parameter often changes from moment to moment depending on the operating conditions of the system and the prevailing weather. For example, if a cloud temporarily shadows the collectors from direct sun, the value of the inlet fluid parameter could easily double, which temporarily decreases efficiency.

Designers are cautioned about assuming any given value of the inlet fluid parameter as “representative” of average operating conditions. Instead, the variability of this parameter is accounted for in system simulation software. The latter is essential in determining the net effect of any collector in a solar combisystem.

FREEZE PROTECTION:

All solar combisystems require a means of protecting the collectors and piping outside of the heated space from freezing. Although there are several possible ways to do this, two methods of freeze protection dominate the market worldwide:

- Use of antifreeze fluid in the collector circuit
- Gravity drainback systems

Each of these systems has advantages and limitations, and several options for each approach will be described.

3. SPACE HEATING OPTIONS:

Not every hydronic space heating distribution system is suitable for use with a solar combisystem. Distribution systems that operate at low water temperatures are greatly preferred because they allow for higher solar energy yields.

Space heating distribution systems that provide design heating load output using supply water temperatures no higher than 120°F will allow the solar subsystem to deliver relatively good performance.

Distribution systems that supply each heat emitter using parallel piping branches rather than series configurations are also preferred because they provide the same supply water temperature to each heat emitter.

Examples of space heating systems that allow the solar subsystem to provide good performance include:

- Heated floor slabs with low-resistance coverings
- Heated thin-slabs over framed floors with low-resistance coverings
- Generously sized panel radiator systems with parallel piping
- Forced-air systems with generously sized water-to-air heat exchangers and carefully placed diffusers that do not create drafts

Each of these will be discussed in more detail.

HEATED FLOOR SLABS:

Heated floor slabs with relatively close tube spacing and low finish floor resistances are generally well suited for use with solar combisystems. The graph in figure 3-1 shows upward heat output from a heated slab based on tube spacing of 6 inches and 12 inches, and for finish floor resistances ranging from 0 to 2.0 (°F•hr•ft²/Btu). The steeper the line, the better-suited the distribution system is for use in a solar combisystem.

For example, achieving an upward heat output of 20 Btu/hr/ft² from a slab with no covering (e.g., Rff = 0) and 6-inch tube spacing requires the “driving ΔT” (e.g., the difference between average water temperature in tubing and room air temperature) to be 17.5°F. Thus, in a room maintained at 70°F, the average water temperature in the circuit needs to be 87.5°F. The supply water temperature to the circuit would likely be in the range of 95–98°F. This is a relatively low supply water temperature, and should allow the collectors to operate at reasonably good efficiency, especially if flat plate collectors are used.

For comparison, consider supplying the same 20 Btu/hr/ft² load using a heated floor slab with 12-inch tube spacing and a finish floor resistance of 1.0°F•hr•ft²/Btu. The driving ΔT must now be 42.5°F. The average circuit water temperature required to maintain a room temperature of 70°F would be 70 + 42.5 = 112.5°F, and the supply temperature likely in the range of 120–123°F. This higher temperature would reduce the efficiency of the solar collectors, and decreases the total energy collected by the system during the heating season. Again, the net effect of such a change on a seasonal basis would have to be assessed through computer simulation of a given system.

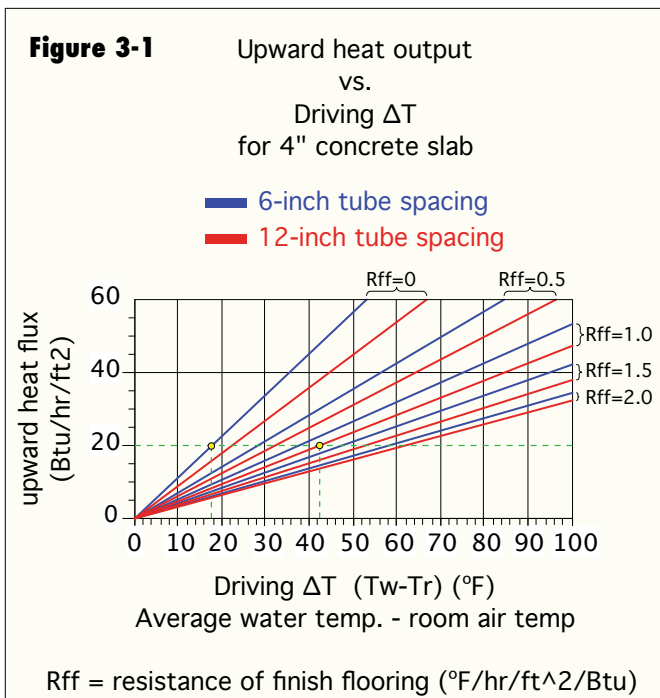

Figure 3-2



The following guidelines are suggested in applications where a heated floor slab will be used to deliver heat derived from a solar collector array:

- Tube spacing within the slab should not exceed 12 inches
- Slab should have minimum of R-10 underside insulation
- Tubing should be placed at approximately 1/2 the slab depth below the surface, as shown in figure 3-2
- Bare, painted or stained slab surfaces are ideal because the finish floor resistance is essentially zero
- Other floor finishes should have a Total R-value of 1.0 or less

HEATED THIN-SLABS:

Another common method of installing floor heating uses a “thin slab” (1.5-inch to 2-inch thickness) poured over a wooden floor deck. Figure 3-3 shows an example of such an installation, awaiting placement of the slab material.

Figure 3-3



Courtesy of H. Youker

Because the slab is thinner than with slab-on-grade floors, it has slightly lower lateral heat dispersal characteristics. This translates into a slightly higher water temperature requirement for a given rate of heat output relative to that required for a slab-on-grade. This difference is slight. A 1.5-inch-thick concrete thin slab with 12-inch tube spacing and covered with a finish flooring resistance of $0.5^{\circ}\text{F}\cdot\text{hr}\cdot\text{ft}^2/\text{Btu}$ yields about 8% less heat output than a 4-inch-thick slab with the same tube spacing and finishing flooring. This can be easily compensated for by using 9-inch rather than 12-inch tube spacing. The following guidelines are suggested:

- Tube spacing within the thin slab should not exceed 9 inches
- Slab should have minimum of R-19 underside insulation
- Floor finishes should have a total R-value of 1.0 or less
- Never use “lightweight” concrete for heated thin slabs

OTHER SITE-BUILT RADIANT PANELS:

Radiant panels can be integrated into walls and ceilings as well as floors. Several of these configurations may be suitable for use with solar combisystems. The key is ensuring the radiant panel can deliver design load output while operating at a relatively low water temperature. This helps ensure the solar collectors will also operate at a relatively low fluid temperature and reasonably good efficiency.

This criterion favors radiant panels that provide high surface areas relative to the rate of heat delivery. It also favors panels that have relatively low internal resistance between the tubing and the surface area releasing heat to the room.

One example is a radiant wall panel constructed as shown in figure 3-4.

When finished, this “radiant wall” is indistinguishable from a standard interior wall. Its low thermal mass allows it to respond quickly to changing internal load conditions or zone setback schedules. The rate of heat emission to the room is approximately 0.8 Btu/hr/ft^2 for each degree Fahrenheit the average water temperature in the tubing exceeds room air temperature. Thus, if the wall operates with an average water temperature of 110°F in a room with 70°F air temperature, each square foot of wall would release about $0.8 \times (110 - 70) = 32 \text{ Btu/hr/ft}^2$. This performance makes it well suited for use with a solar combisystem.

Another possibility is a radiant ceiling using the same type of construction as the radiant wall, as shown in figure 3-5.

As with the radiant wall system, this radiant ceiling has low thermal mass and responds quickly to interior temperature changes. Heated ceilings also have the advantage of not being covered or blocked by coverings or furniture, and thus are likely to retain good performance over the life of the building.

For the construction shown, the rate of heat emission is approximately 0.71 Btu/hr/ft^2 for each degree Fahrenheit

Figure 3-4

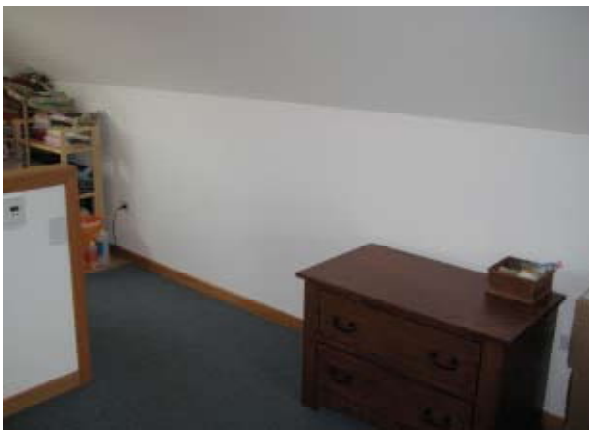
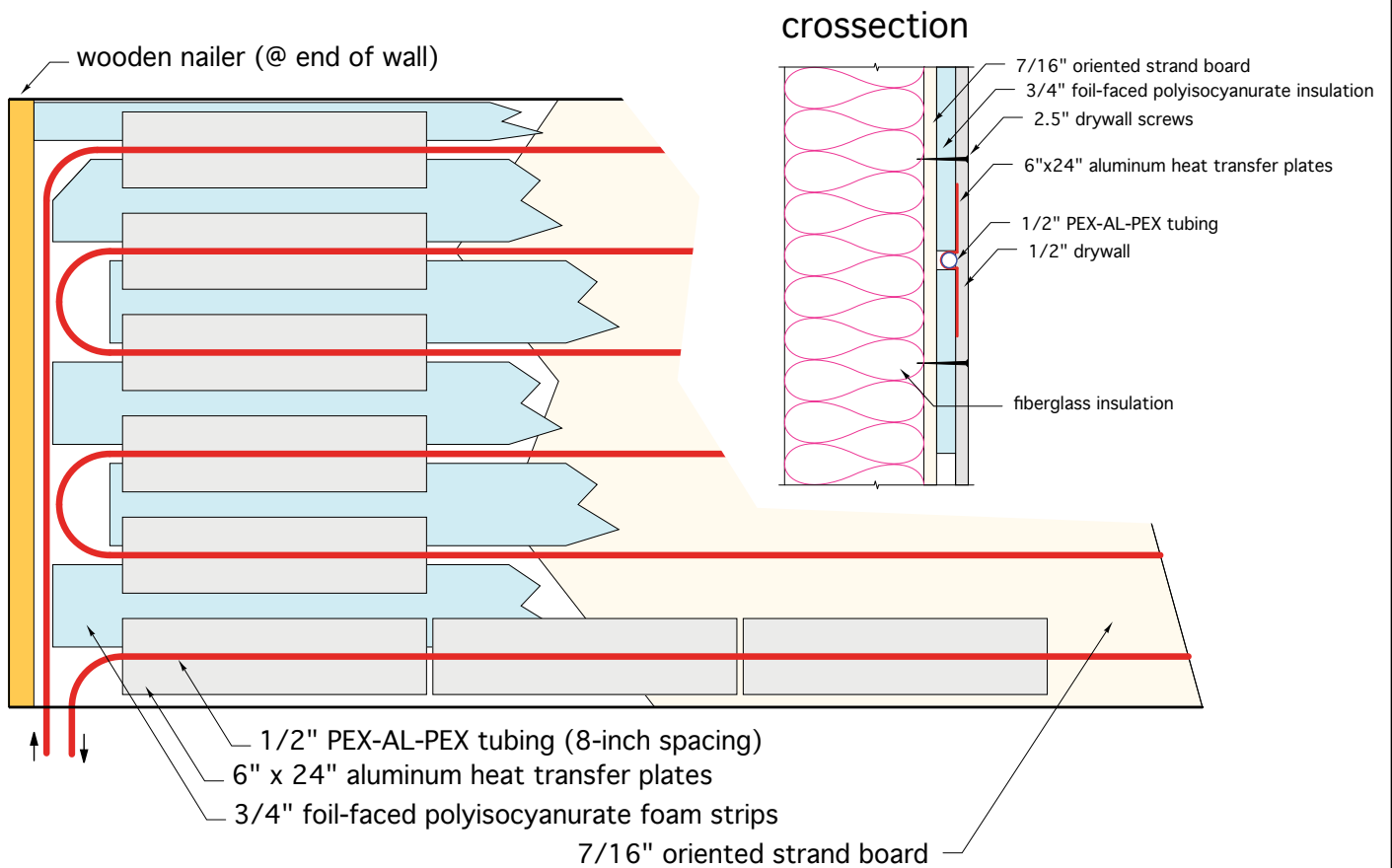

finished radiant wall

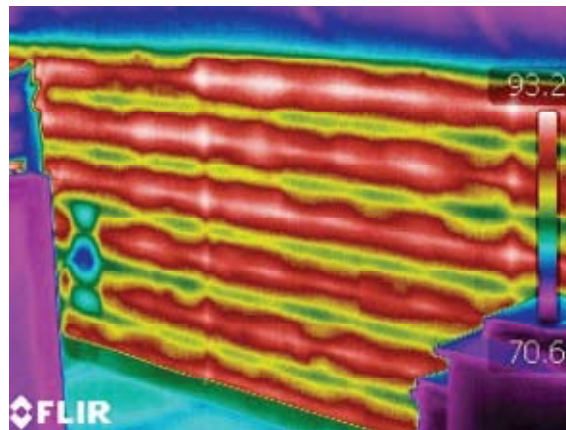

thermal image of wall in operation

$$\frac{Btu}{hr \cdot ft^2} = (0.8) \times (T_{water} - T_{room})$$

Figure 3-5

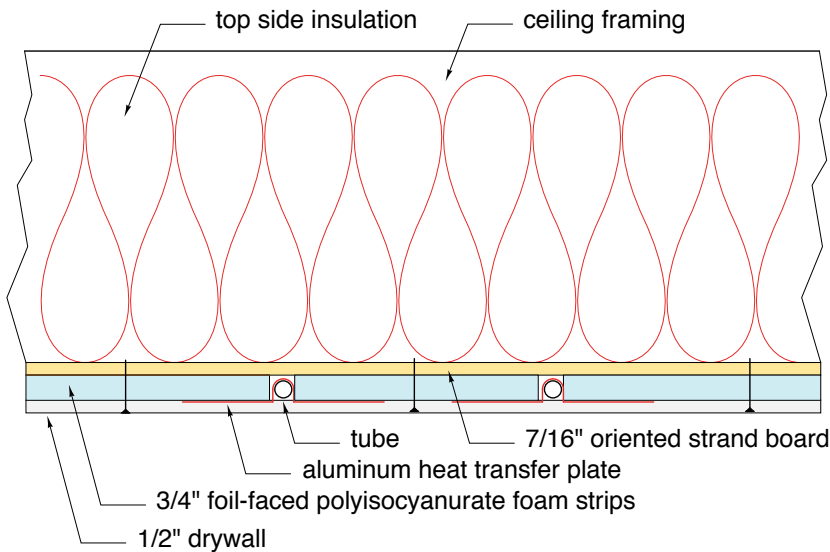

finished radiant wall

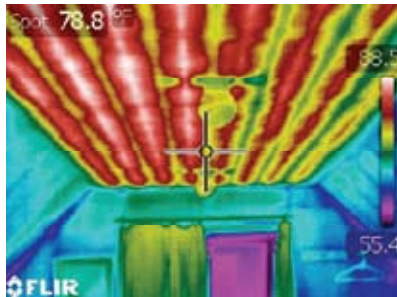

thermal image of ceiling in operation

$$\frac{Btu}{hr \cdot ft^2} = (0.71) \times (T_{water} - T_{room})$$

Manufacturers provide output ratings for their panel radiators in either graphical or tabular form. In many cases, “reference” heat output ratings for a given size panel are stated along with corresponding water temperature and room air temperatures. Correction factors are then given, which, when multiplied by the reference heat output, give the actual heat output for specific water and room air temperatures.

Figure 3-6 shows a typical fluted water panel radiator. Figure 3-7 gives reference heat output ratings for this type of panel based on an average panel water temperature of 180°F and room air temperature of 68°F. Figure 3-8 gives correction factor to modify the reference heat output ratings based on different average water temperatures and room air temperatures. The formula on the graph in figure 3-8 can also be used to calculate these correction factors.

For example: Figure 3-7 indicates that a panel with a

the average water temperature in the tubing exceeds room air temperature. Thus, if the ceiling operated with an average water temperature of 110°F in a room with 70°F air temperature, each square foot of wall would release about $0.71 \times (110 - 70) = 28.4$ Btu/hr/ft². This performance makes the radiant ceiling well suited for use in a solar combisystem.

PANEL RADIATORS:

Generously sized panel radiators can also provide good performance when used as part of a solar combisystem. Again, the suggested guideline is to size panels so they can deliver design space heating output using a supply water temperature no higher than 120°F.



Figure 3-6

Courtesy H. Youker

Figure 3-7

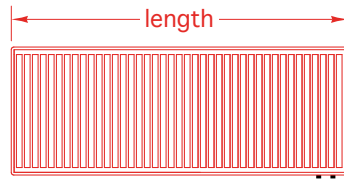

Heat output ratings (Btu/hr)
at reference conditions:
Average water temperature in panel = 180°F
Room temperature = 68°F
temperature drop across panel = 20°F

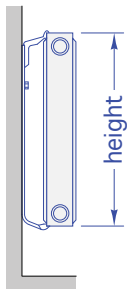

	1 water plate panel thickness					
	16" long	24" long	36" long	48" long	64" long	72" long
24" high	1870	2817	4222	5630	7509	8447
20" high	1607	2421	3632	4842	6455	7260
16" high	1352	2032	3046	4060	5415	6091

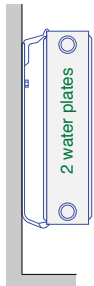

	2 water plate panel thickness					
	16" long	24" long	36" long	48" long	64" long	72" long
24" high	3153	4750	7127	9500	12668	14254
20" high	2733	4123	6186	8245	10994	12368
16" high	2301	3455	5180	6907	9212	10363
10" high	1491	2247	3373	4498	5995	6745



	3 water plate panel thickness					
	16" long	24" long	36" long	48" long	64" long	72" long
24" high	4531	6830	10247	13664	18216	20494
20" high	3934	5937	9586	11870	15829	17807
16" high	3320	4978	7469	9957	13277	14938
10" high	2191	3304	4958	6609	8811	9913

single water plate, measuring 24 inches high and 72 inches long, has a heat output of 8447 Btu/hr based on the reference conditions of 180°F average water temperature and 68°F room air temperature. Using the formula in figure 3-8, the correction factor with an average panel water temperature of 110°F and room temperature of 68°F is:

$$CF = 0.001882(110 - 68)^{1.33} = 0.271$$

The estimated heat output at the lower water temperature is thus:

$$Output = (0.271) \times 8447 = 2289 \text{ Btu} / \text{hr}$$

This example demonstrates that systems limiting the supply water temperature to 120°F to retain good performance of the solar collectors often require substantially larger panel radiators compared to systems with conventional heat sources that often supply much higher water temperatures.

When panel radiators are used in a solar combisystem, they should be piped in parallel. Ideally, each panel radiator is served by its own supply and return piping. A manifold-based distribution system, as shown in figure 3-9, uses small diameter PEX or PEX-AL-PEX tubing to supply each radiator. Tube sizes in such systems varies from 3/8-inch to 5/8-inch depend on flow rate and head loss allowances. This type of distribution system is well suited for solar combisystems and is shown in several subsequent schematics.

Figure 3-8

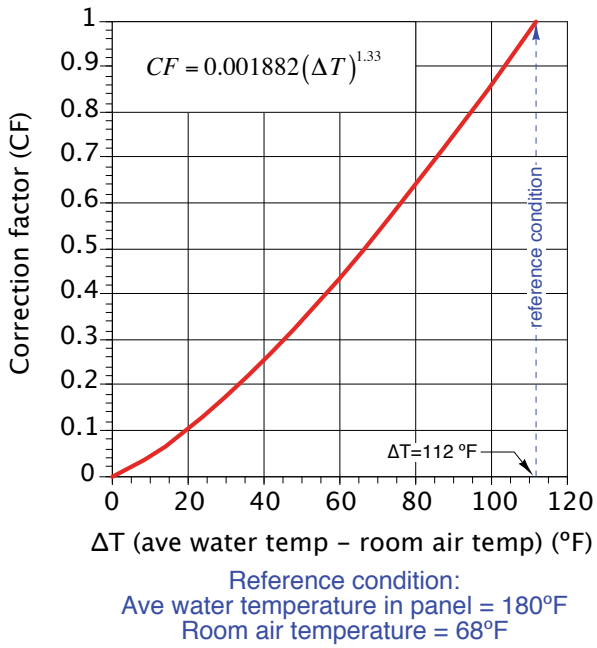

FORCED-AIR DISTRIBUTION SYSTEMS:

Although most solar combisystems use hydronics technology, it is possible to use a forced-air system to deliver both the solar-derived heat and any necessary auxiliary heat to the building. This is usually done using a hot water coil mounted in the plenum of the air handling device (furnace, heat pump indoor unit, etc.), as shown in figure 3-10.

The coil is mounted on the discharge plenum to avoid heating the components inside the air handler. Although this may not be an issue with devices such as furnaces, it could void warranties on other types of air handlers containing refrigeration components.

The check valve installed in the pipe supplying the plenum coil prevents reverse heat migration from the furnace to the solar storage tank when the latter is too cool for use.

An air temperature sensor is located in the discharge plenum, downstream of the coil. This is used in

Figure 3-9

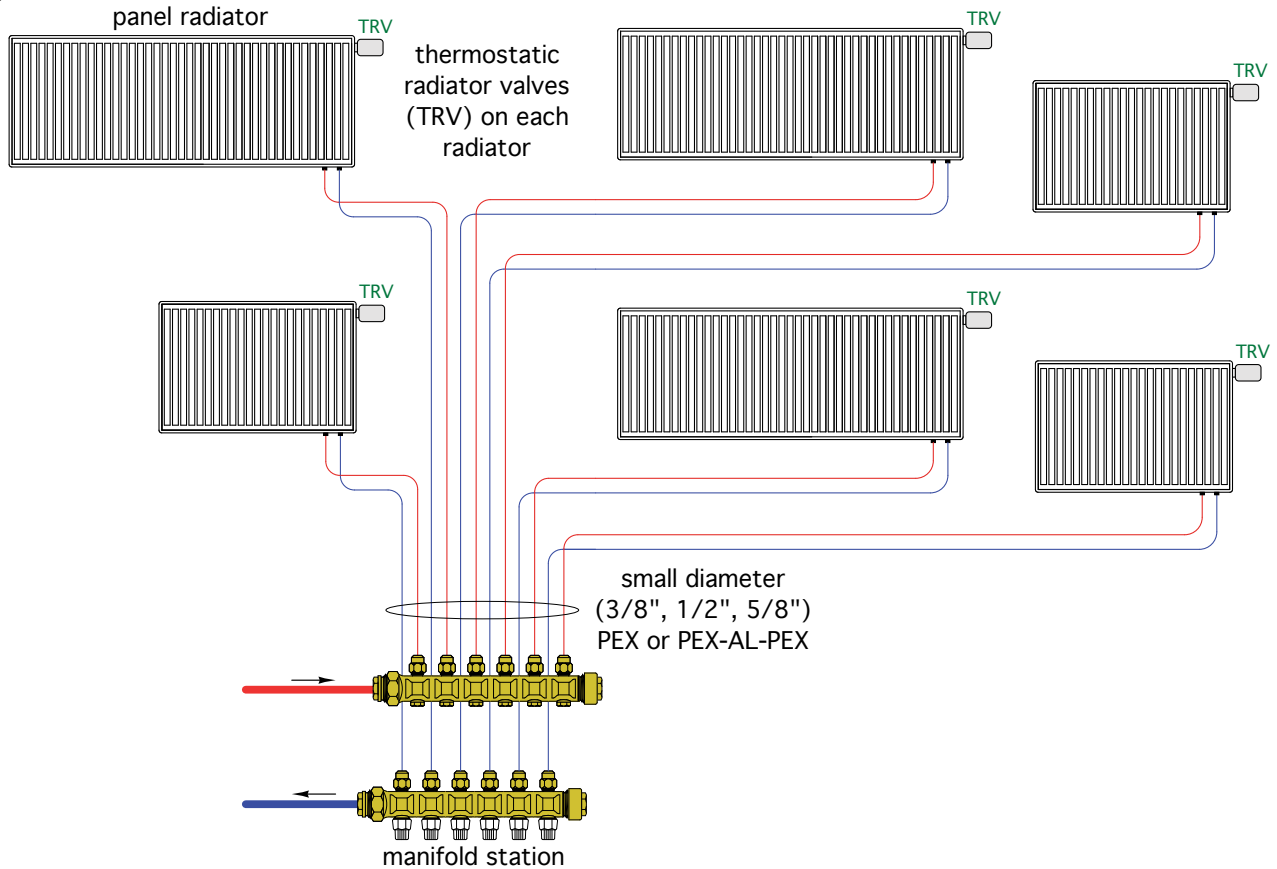

Figure 3-10

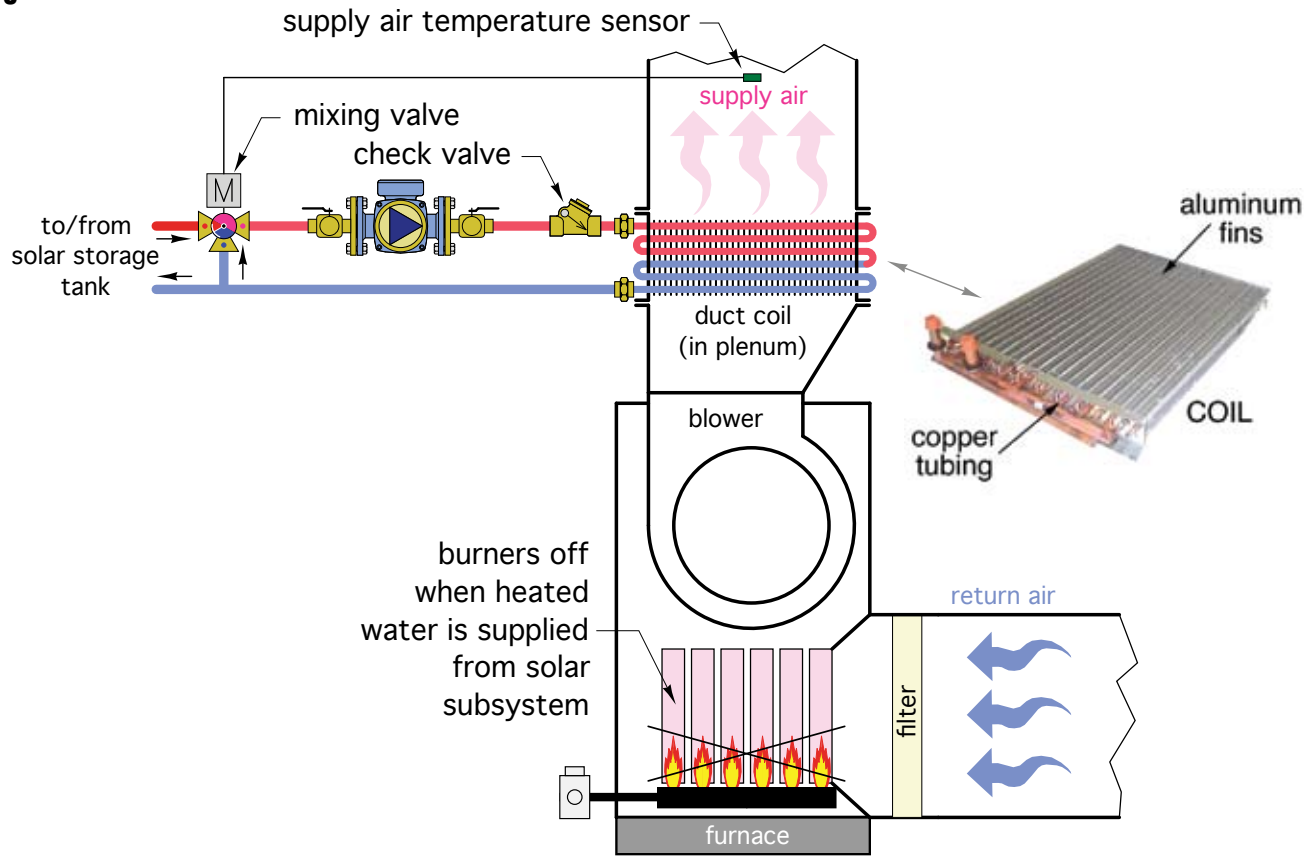

Figure 3-11



combination with a mixing device to regulate the temperature of the supply air stream. Such regulation prevents very hot water in the solar storage tank from creating a burst of very warm air to the heated space.

The size of the plenum coil should allow relatively low water temperatures in the solar storage tank to meet the heating load. Coils with multiple tubing rows and large aluminum fins improve heat transfer at low water temperatures, and as such are preferred. Coil manufacturers can size coils for the required rates of heat transfer at specified entering water and air temperatures.

This type of system may not always create supply air temperatures as high as those created by a furnace, especially if the water temperature supplied to the coil is regulated by outdoor reset control. The registers and diffusers used for such a system should be carefully sized and placed to avoid creating drafts within the heated space. Ideally, supply air from the diffusers should be mixed with room air above the occupied zone. Vertical air velocities into the occupied zones should be minimized to avoid drafts.

Fin-tube baseboards, although commonly used in conventional hydronic systems, generally do not provide good performance

in solar combisystems. Most systems using fin-tube baseboard are designed around relatively high water temperatures (180°F or higher). While it is possible to lower the supply water temperature by adding fin-tube baseboard to the system, lowering it from 180°F to 120°F typically requires about 3.5 times as much fin-tube length for the same heat output. Few rooms can physically accommodate this, and few occupants would accept the associated aesthetics.

Some radiant floor panels require water temperatures well above 120°F at design load conditions. Such panels will not allow a solar thermal subsystem to perform as well as the previously discussed radiant panels. Careful analysis using solar simulation software can quantify the differences in expected solar subsystem performance.

Cast iron radiators sized for steam heating but converted for use with higher temperature water are also unlikely to be suitable. The possible exception would be a building that has undergone extensive weatherization since the steam radiators were installed. In some cases, the significant reduction in heating load relative to the surface area of the original radiators might allow operation at water temperatures within the range that can be consistently supplied by solar collectors. In such cases, the original radiator system should also be internally cleaned and flushed to remove any accumulated residue associated with steam heating.

4. ANTIFREEZE-BASED SOLAR COMBISYSTEMS

The use of antifreeze fluids to protect solar collectors and exposed piping against freezing is very similar to its use in other hydronic systems. The piping circuits containing the antifreeze solution are closed loops. When the system is commissioned, these loops are purged of air and slightly pressurized. In a closed, fluid-filled piping circuit, the weight of the upward flowing fluid is exactly balanced by that of the downward flowing fluid.

ADVANTAGES OF ANTIFREEZE-BASED SYSTEMS:

In a properly purged closed piping circuit, the circulator is only responsible for overcoming the head loss due to friction between the piping components and the fluid. It is not responsible for “lifting” fluid into unfilled piping. That task is handled by a separate filling/purging pump. Thus, the circulator in a closed, fluid-filled piping loop can be relatively small. In residential combisystems, the collector loop circulator might only require 25 watts or less of electrical input energy. This keeps the operating cost of the solar collection subsystem low.

Another advantage of antifreeze-based systems is that tubing to and from the collector array can be installed in any orientation. This allows flexible stainless steel or other types of coiled metal tubing to be installed in spaces where it would be difficult or impossible to install rigid tubing, or to maintain a minimum slope on that tubing.

DISADVANTAGE OF ANTIFREEZE-BASED SYSTEMS:

One disadvantage of antifreeze-based systems is that a heat exchanger is required between the antifreeze solution in the collector circuit and the water in the remainder of the system. Any heat exchanger imposes a performance penalty on the system because it forces the collector circuit to operate at a temperature higher than that of the water near the bottom of the storage tank. The magnitude of this temperature difference depends on the sizing of the heat exchanger. The greater the internal surface of the heat exchanger is relative to the rate of heat transfer, the less the performance penalty. The performance of heat exchangers and the penalty factor they impose on solar combisystems are discussed in Appendix B.

Another disadvantage of antifreeze-based systems is that glycol-based antifreeze will chemically degrade and become acidic over time. In such a state, the fluid can cause internal corrosion of both piping and collectors, eventually leading to failure. This degradation is accelerated at higher temperatures. It is not good for glycol-based fluids to be maintained at high temperatures over long periods of time. This can happen in solar combisystems that generate far more heat in summer than is required by the load. It also implies that annual testing of the pH and reserve alkalinity of glycol-based antifreeze solutions is imperative.

HEAT DUMP PROVISIONS:

The potential for thermal degradation of glycol-based antifreeze solutions justifies the need for a “heat dump” provision on antifreeze-based solar combisystems. The heat dump provides a way for the system to shed excess heat when the solar storage tank has reached a user-set upper temperature limit and there is no immediate need for further heat in the system. Heat dumps can take the form of:

- Additional storage tanks.
- Passive or fan-forced convectors through which the hot antifreeze solution is diverted when necessary. These convectors are typically located outside the building and dissipate heat directly to outdoor air.

- Heat exchangers that dissipate surplus heat to high thermal capacity loads, such as swimming pools, spas or buried earth loops. The latter is well-suited for geothermal heat pump systems in climates with relatively small cooling loads.

- Nocturnal cooling — the antifreeze solution is circulated between the tank heat exchanger and the collector array at night to dissipate heat back to the atmosphere. In some systems, the check valve in the collector loop can be manually opened to allow nocturnal cooling without operation of the circulator. Note: Nocturnal cooling can only be used with flat plate collectors.

Heat dumps (other than nocturnal cooling) are usually brought online using an electrically operated diverting valve. In its unpowered state, this valve allows the antifreeze solution to flow between the collector array and the normal load — such as a heat exchanger in the solar storage tank.

When the solar tank reaches a user-specified temperature limit, the solar system controller powers up the diverting valve. The heated antifreeze solution returning from the collector array is then routed to the heat dump. If, during the heat dump mode, the solar storage tank temperature drops, the solar system controller discontinues the heat dump mode and redirects the heated antifreeze to the normal load.

Power outages are one of the chief causes of collector stagnation. For a heat dump to be effective during such times, it must be able to operate in the absence of utility-supplied power. DC circulators operated from batteries are one possibility. Passive heat dissipation devices that operate based on buoyancy-driven flow are another.

Heat dump subsystems should be sized to dissipate the entire heat gain of the collector array during a warm and sunny summer day and with no load assumed on the system. This is based on the premise that two or more such days could occur in sequence, and that the first could bring the solar storage tank to its upper temperature limit. The absence of load during this scenario is based on the occupants being away from the building.

ANTIFREEZE-BASED COMBISYSTEM DESIGNS:

Solar combisystems can be designed many ways depending on project requirements and constraints. For example, a narrow doorway might require that a system needing several hundred gallons of storage is designed around multiple smaller tanks rather than a

single large tank. A ground-mounted collector array may not provide the elevation change required for a drainback system, and thus the only choice would be an antifreeze-based system. The size of the space heating load and the type of auxiliary heat used will certainly influence overall system design. In short, there is no “universal” design concept for a solar combisystem that suits all situations.

The remainder of this section discusses several “templates” for solar combisystems that can work for many residential or light commercial applications. All these systems use antifreeze-based closed collector circuits. Section 5 will present several additional templates for drainback combisystems.

ANTIFREEZE-BASED COMBISYSTEM #1:

The first design presented is a natural extension of a solar domestic water heating system. It adds an auxiliary storage tank to accept heat from the collector array whenever it’s available, and the domestic hot water storage tank has reached a user-set maximum temperature. A piping schematic for the system is shown in figure 4-1.

A standard solar circulation station like that used in a solar DHW system controls flow through the collector array. Whenever the temperature sensor (S2) on the domestic water tank is below a user-selectable maximum setting, flow returning from the collectors is routed to the left, through the internal heat exchanger in the DHW storage tank. It then passes into the “B” port of the 3-way diverter valve (D1), out through the “AB” port and back to the supply side of the solar circulation station. The diverter valve is not energized in this mode. There is no flow through the coil in the auxiliary storage tank. A spring-loaded check valve helps prevent heat migration into the auxiliary storage tank during this mode.

If the solar controller detects that temperature sensor (S2) has reached the maximum temperature setting, it applies line voltage to the diverter valve (D1). Hot antifreeze solution returning from the collectors is now routed through the coil of the auxiliary storage tank.

As heat is diverted to the auxiliary storage tank, the solar controller continues to monitor the temperature of the DHW tank sensor (S2). If its temperature drops a preset amount, the diverter valve (D1) reverses position to route the antifreeze solution returning from the collectors through the coil in the DHW tank. The solar controller always treats the DHW storage tank as the “priority” load, directing heat to it whenever its temperature is under a user-specified maximum value.

Figure 4-1

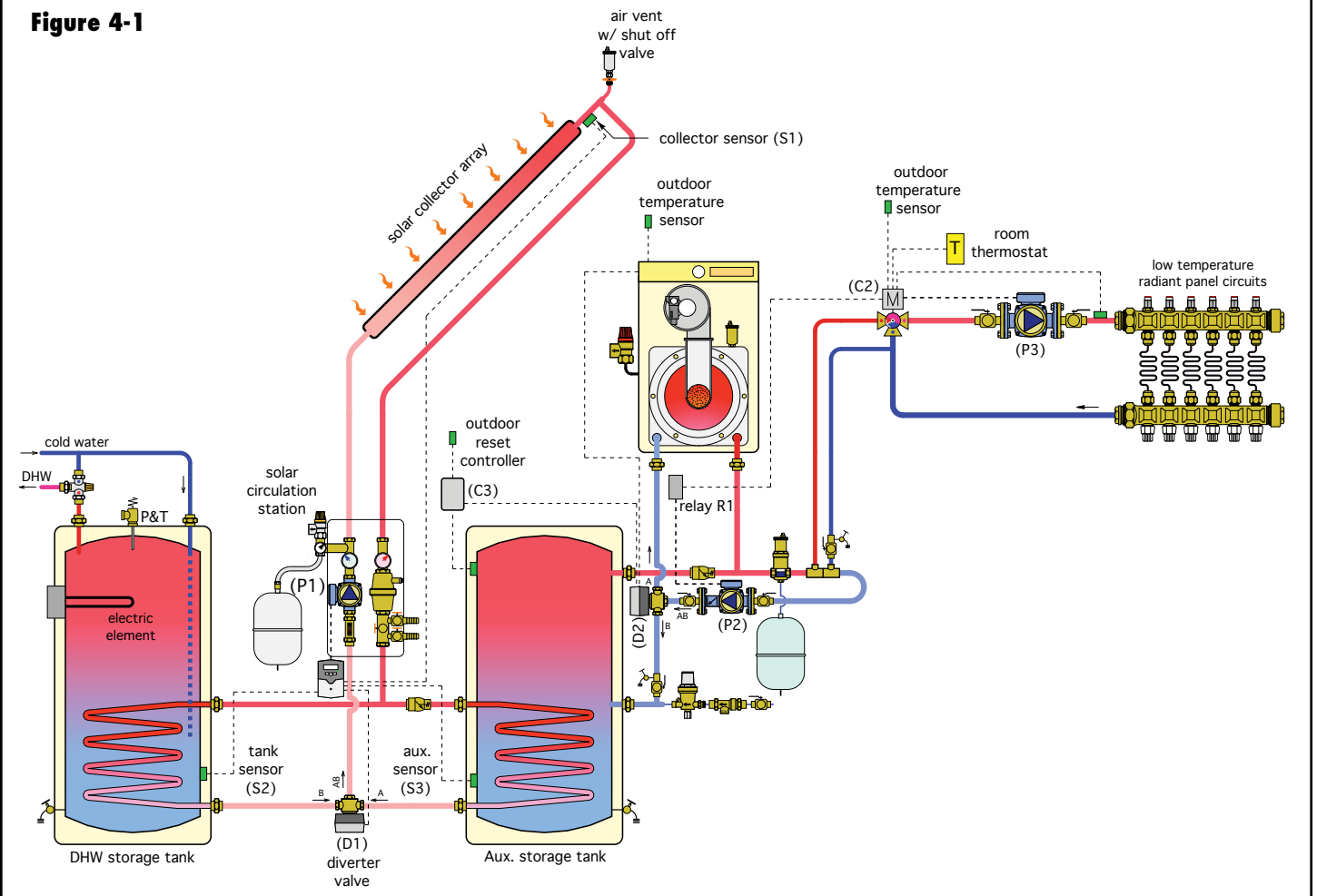

Figure 4-2

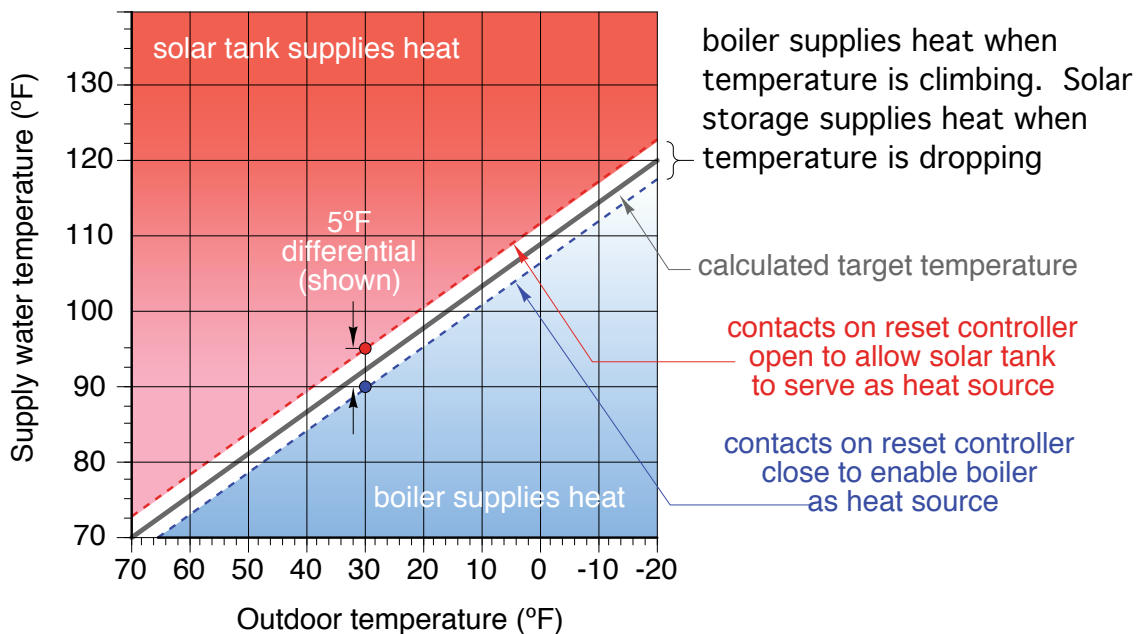
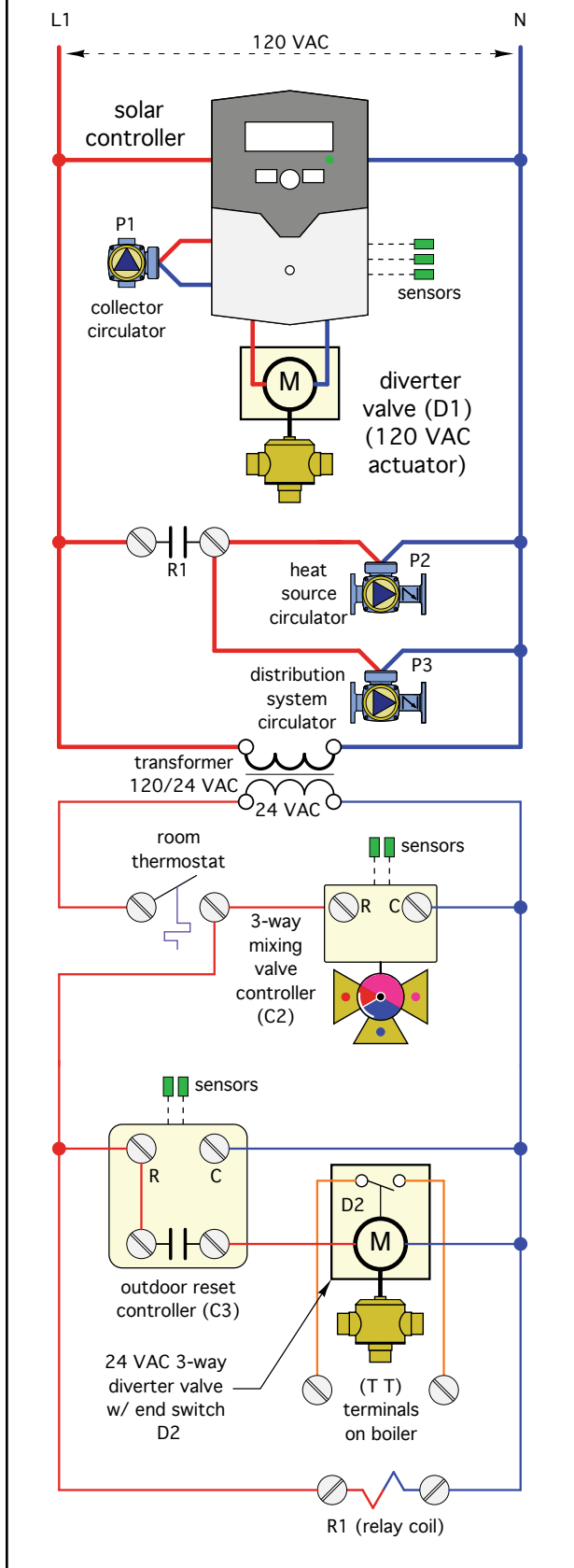

Figure 4-3



The temperature the auxiliary storage tank reaches depends on the load and solar availability. During a sustained sunny period, it is possible for the auxiliary tank to reach a temperature well above that needed by the space heating distribution system.

In this system, a call for space heating comes from a thermostat, which switches 24 VAC power to the 3-way motorized mixing valve, allowing it to begin operation. 24 VAC power also powers up the coil of relay (R1), which switches line voltage to operate circulators (P2) and (P3). 24 VAC power also energizes the outdoor reset controller (C3), which calculates the required supply water temperature for the space heating based on its settings and the outdoor temperature. An example of the logic used by the outdoor reset controller is shown in figure 4-2.

The sloping gray line represents the “target” temperature, which is the ideal supply water temperature (read from the vertical axis) for a corresponding outdoor temperature (read from the horizontal axis). The slope of the gray line can be adjusted by changing the settings on the controller. The dashed blue line below the gray line indicates the temperature at the supply sensor at which the output contacts on the outdoor reset controller close. The dashed red line above the gray line indicates the temperature at the supply sensor where these contacts open.

If, for example, the outdoor temperature is 30°F, the calculated target temperature shown in figure 4-2 is 92.5°F. The lower dashed line indicates the output contacts close if the temperature at the supply sensor is 90°F or less. The upper dashed line indicates these contacts open if the temperature at the supply sensor is 95°F or more.

The controller’s supply sensor measures the temperature near the top of the auxiliary storage tank. Thus, with these settings, if the outdoor temperature is 30°F, and the temperature near the top of the auxiliary storage tank is 90°F or less, the controller determines that the auxiliary storage tank is too cool to supply the space heating distribution system. It closes its output contacts to power on the diverter valve (D2), allowing it to change position so flow passes through the boiler. When the diverter valve completes its rotation, an end switch in its actuator closes to fire the boiler.

When there is a call for space heating, and the temperature at the top of the auxiliary tank is 95°F or higher, the outdoor reset controller allows the auxiliary storage tank to serve as the heat source for the distribution system.

If the storage tank is serving as the heat source, it continues to do so until the tank sensor temperature drops to 90°F, at which point the system automatically switches to the boiler as the

heat source. If the boiler is serving as the heat source, it continues to do so until the tank temperature climbs above 95°F, at which point the auxiliary tank becomes the heat source.

Keep in mind that these temperatures change based on the current outdoor temperature. The slope of the reset line and the differential of the outdoor reset controller can also be adjusted to suit the type of heat emitters and auxiliary heat source used in the system.

This simple logic for switching between heat sources allows the solar storage tank to be utilized to the lowest possible temperature that can still satisfy the space heating load. This improves collector efficiency, and increases total solar energy collection over the heating season.

A wiring schematic for this system using the control method described above is shown in figure 4-3.

ANTIFREEZE-BASED COMBISYSTEM #2:

Some combisystems are designed around a single storage tank. The energy in this tank supplies both domestic hot water and space heating. One example of such a system is shown in figure 4-4.

Solar energy is added to this tank through the lower heat exchanger coil. In smaller combisystems, a solar circulation station (as shown) could likely handle flow through the collector array.

The storage tank contains potable water. The upper heat exchanger coil is used to extract heat from this water for use by the space heating system. It is also used to *add* heat produced by the boiler to the water at the top of the tank. The latter mode ensures that domestic hot water is always available at a suitable supply temperature regardless of solar energy input.

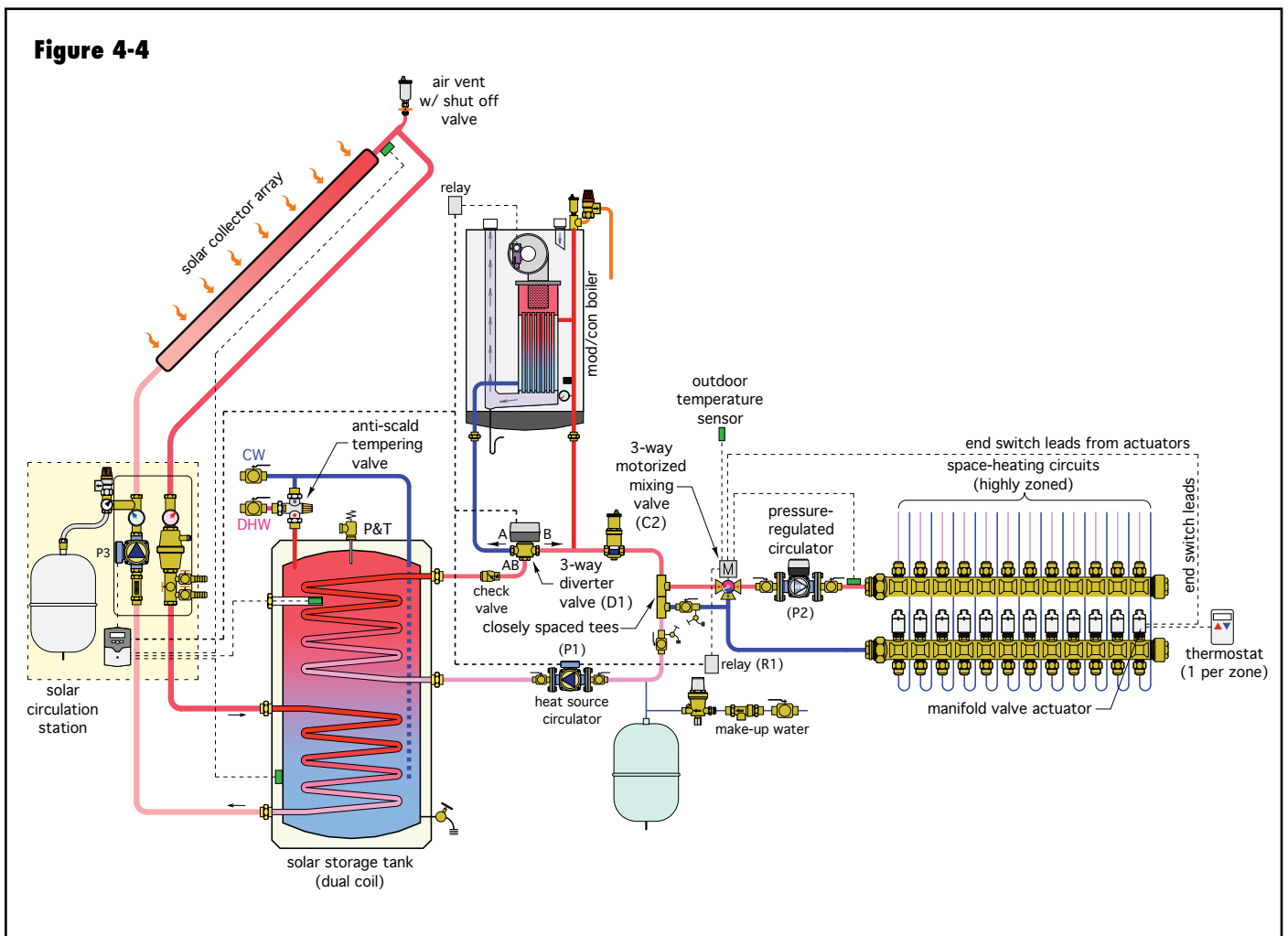
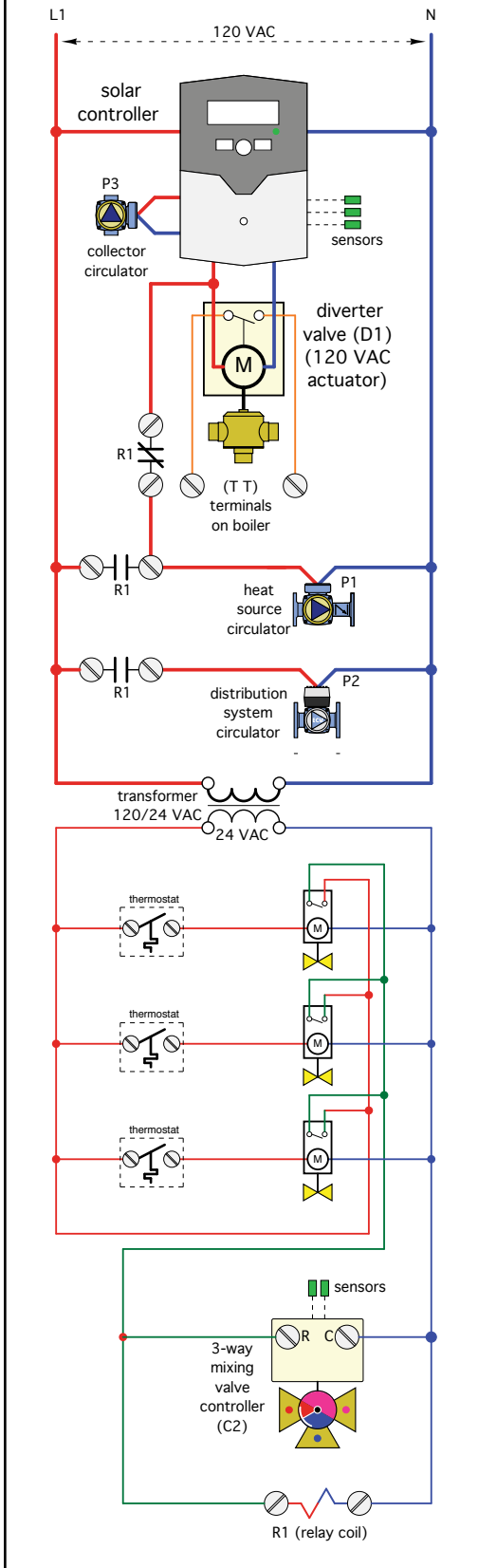

Figure 4-5



Temperature stratification helps keep this heat at the top of the tank. The bottom of the tank remains as cool as possible to maximize collector efficiency. The spring-loaded check valve at the upper outlet of the tank reduces heat migration through the attached piping. Its function is especially important in warm weather when no space heating is required.

A wiring diagram for this system is shown in figure 4-5.

In this system, the solar controller determines when the top of the tank requires heating, and if so, turns on the boiler, the heat source circulator (P1) and powers up the 3-way diverter valve (D1) so flow passes through the boiler and eventually the upper tank coil. In systems where the solar controller does not provide this logic, it can be created using standard hydronic control hardware as described for the previous system.

A call for heating is initiated by any zone thermostat, which powers up one of the manifold valve actuators. When the associated manifold valve is fully open, an end switch within the actuator closes. This provides 24 VAC power to operate the 3-way motorized mixing valve (C2), which then regulates supply temperature to the distribution system based on outdoor temperature. Relay (R1) is also energized to turn on the heat source circulator (P1), and the distribution circulator (P2).

If the boiler is NOT operating, there is no power to the 3-way diverter valve (D1). Flow passes from the tank's upper coil into the "AB" port of the diverter valve, and then out through the valve's "B" port. It moves on through the air separator to a pair of closely spaced tees. The latter provide hydraulic separation between circulators (P1) and (P2). Hot water passes from the side port of the upper tee to the hot port of the motorized mixing valve as required to achieve the necessary supply temperature. The distribution system could supply any of the lower temperature heat emitters discussed earlier, and it could be extensively zoned. In the latter case, a variable-speed pressure-regulated circulator (P2) provides differential pressure control in response to operation of the zone valves. A normally closed contact on relay (R1) is now open to prevent line voltage from energizing the diverter valve (D1).

When the temperature in the upper portion of the storage tank drops to a lower limit, (based on the system's ability to supply adequate domestic hot water), the diverter valve (D1) is powered on by the solar controller. Flow now passes from this valve's "AB" port out through its "A" port and onward through the boiler. When the diverter valve (D1) reaches the end of its travel, an end switch within the valve's actuator closes to fire the boiler.

If the space heating distribution system is also operating while the boiler is firing, some of the boiler's heat output is used for space heating. Any remaining heat output is transferred to the upper portion of the storage tank by the upper heat exchanger coil. If the space heating distribution system is not operating, line voltage from the solar controller passes through the normally closed relay contact (R1) to operate the heat source circulator (P1).

This configuration allows the thermal mass of the water in the upper portion of the tank to buffer the space heating load, and thus helps prevent boiler short cycling. This is especially beneficial when the distribution system is extensively zoned.

ANTIFREEZE-BASED COMBISYSTEM #3:

The functionality of antifreeze-based system #2 can also be achieved using slightly different hardware. Figure 4-6 shows a very similar solar subsystem to that used in figure 4-4. The difference is an external stainless steel brazed plate heat exchanger rather than an upper coil in the storage tank.

Domestic hot water from the storage tank flows through the external heat exchanger based on the operation of a small bronze or stainless steel circulator (P3). This pump can be configured for either constant-speed or variable-speed operation. Figure 4-6 shows two different piping arrangements based on how circulator (P3) is controlled.

If the speed of circulator (P3) is varied (as shown in the upper portion of figure 4-6), it can meter domestic hot water through the external heat exchanger such that the water temperature supplied to the space heating distribution system also varies. The higher the speed of circulator (P3), the faster heat transfers across the heat exchanger and the warmer the distribution system becomes.

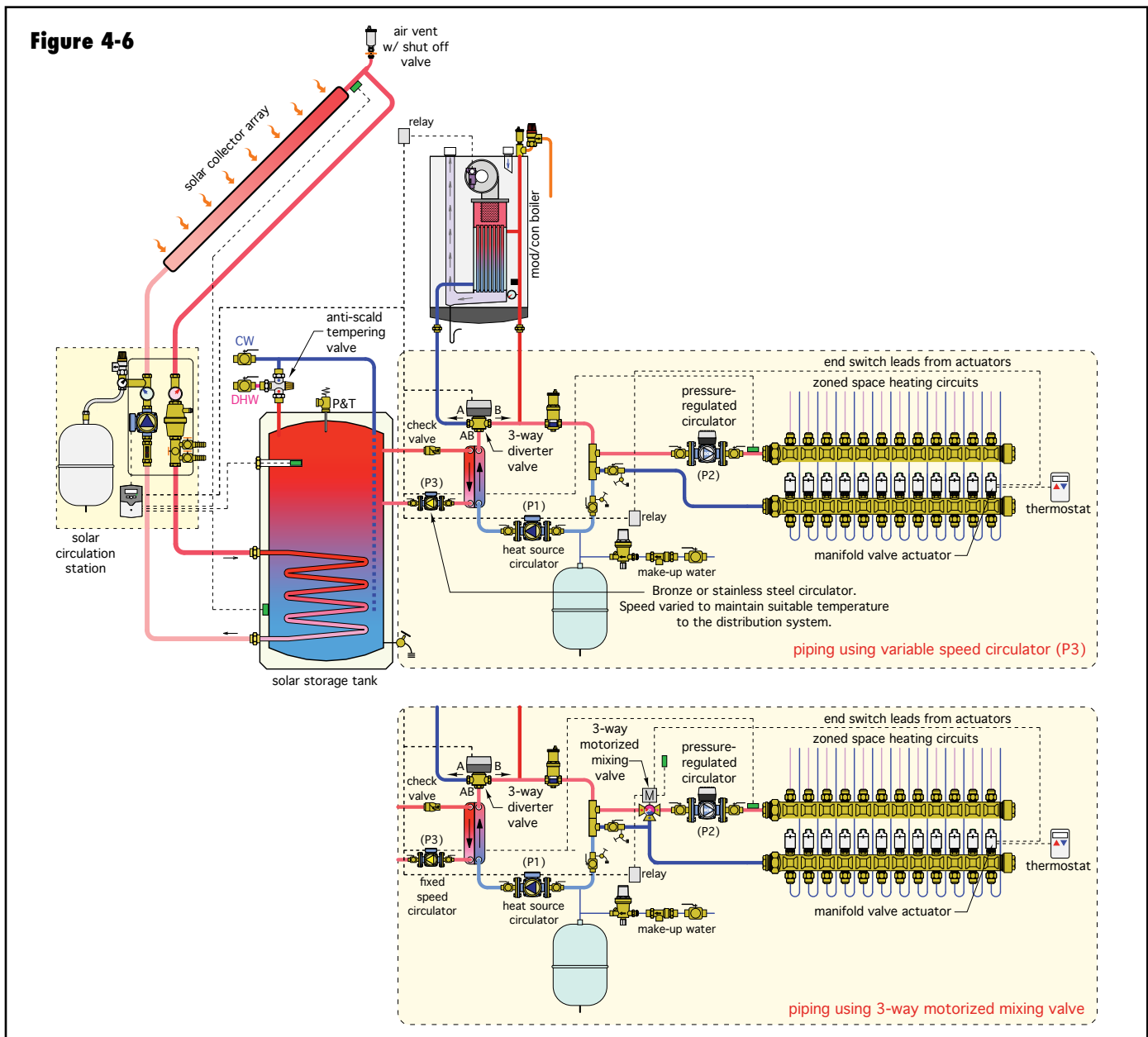

The speed of circulator (P3) could be varied based on maintaining a fixed supply temperature to the distribution system. It could also be varied based on outdoor reset logic.

The ability to control the speed of circulator (P3) also prevents what could be very hot water in the solar storage tank from flowing directly to a low-temperature distribution. As such, it eliminates the need for a motorized mixing valve in most applications. However, if the distribution system operates at very low water temperatures relative to the minimum temperature maintained in the top of the storage tank (for delivery of domestic hot water), the space heating distribution circulator (P2) should be temporarily turned off while the boiler is heating the top of the storage tank. Circulator (P3) should also operate at full speed during this mode to maximize heat transfer across the heat exchanger. When the top of the storage tank has reached the preset water temperature, variable-speed operation of circulator (P3) can resume.

If circulator (P3) is operated in an on/off manner, a mixing valve is required in the distribution system. Circulator (P3) would turn on whenever the boiler is operating as well as when there is a call for space heating.

One advantage of either of these approaches is that the external heat exchanger is serviceable or replaceable if ever necessary. Another advantage is that the thermal mass of the water in the storage tank will buffer a highly zoned space heating distribution system, and thus reduce the potential for boiler short cycling.

ANTIFREEZE-BASED COMBISYSTEM #4:

There are many homes and commercial buildings with forced-air distribution systems for heating. It is possible to build a solar combisystem using hydronic hardware to collect and convey solar energy, and then pass this energy to a forced-air distribution system. One approach is shown in figure 4-7.

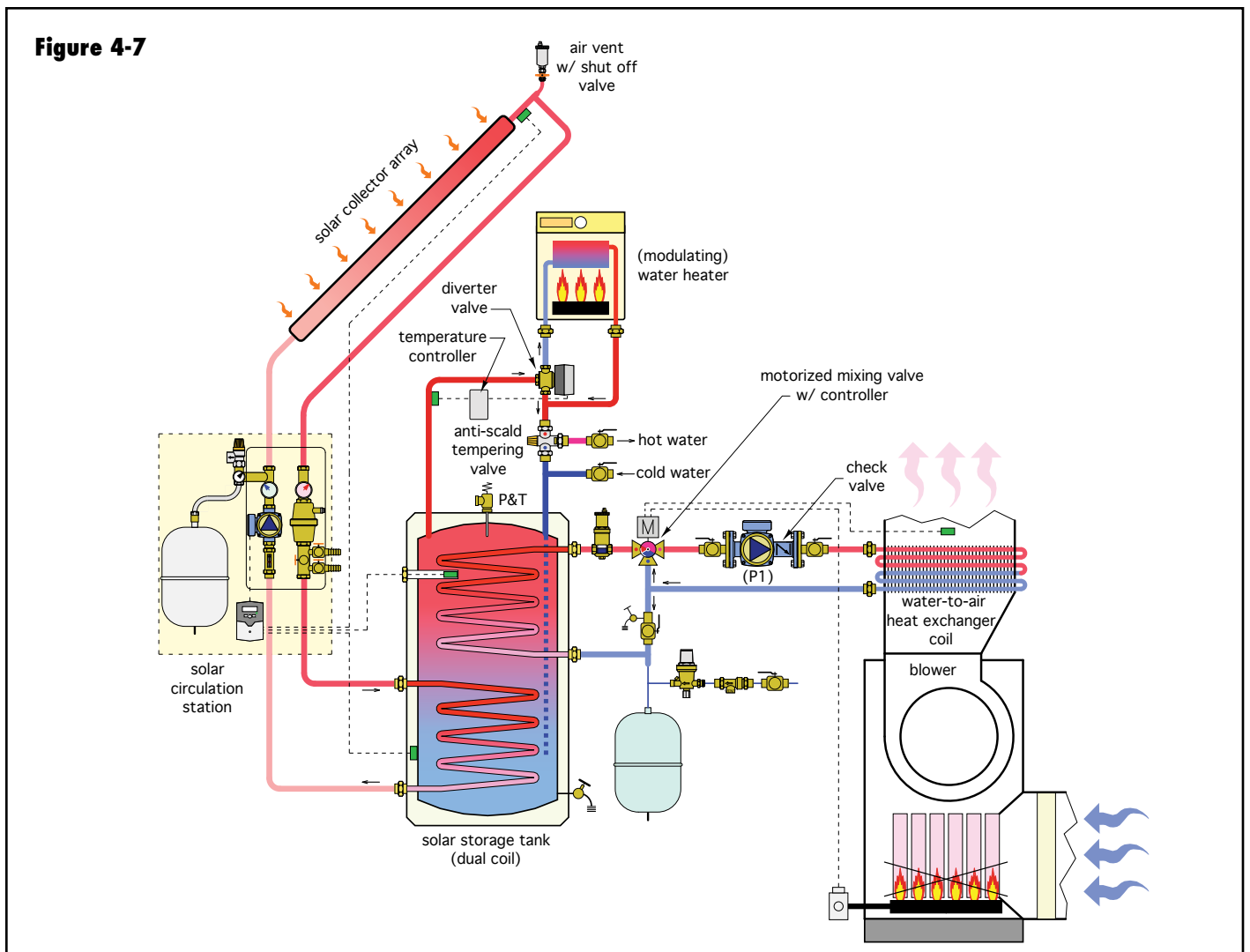

The solar collection subsystem is essentially the same as in previous systems.

The storage tank contains domestic water and absorbs solar-derived heat through the lower coil.

If the domestic water leaving the tank needs a further temperature boost, it is routed through the modulating instantaneous water heater via a 3-way diverter valve, which is operated by a setpoint temperature controller. If this controller determines that domestic water leaving the tank does not need further heating, the diverter valve routes flow directly to the hot port of an anti-scald tempering valve. This configuration eliminates the heat loss associated with passing heated water through the unfired water heater.

Any instantaneous water heater used in this type of system must modulate its firing rate to adjust for preheated incoming water. Verify that any instantaneous water heater being considered for such an application is warranted for use with solar combisystems that supply preheated domestic water.

Upon a call for space heating, a controller determines if the temperature at the top of the storage tank is sufficient to supply the water-to-air heat exchanger coil mounted in the supply plenum of the forced-air distribution system. This decision can be based on outdoor reset control. However, designers are cautioned that low-temperature supply air must be carefully introduced into heated spaces to avoid drafts. This may require a lower temperature limit on the reset controller.

A motorized mixing valve monitors the temperature of the supply air downstream of the plenum coil. The mixing valve adjusts itself as required to prevent potentially high-temperature water in the storage tank from creating overly hot supply air to the building.

If the tank's temperature is too low to properly supply the plenum coil, the furnace's burner (or the compressor in a forced-air heat pump system), would operate as normal. The space heating circulator (P1) would be off. A check valve in this circulator, or mounted as a separate component, prevents heat in the plenum from migrating backward into the hydronic system.

ANTIFREEZE-BASED COMBISYSTEM #5:

Another possible system configuration uses a storage tank with an integral gas-fired heat source, as shown in figure 4-8. This eliminates the boiler as a separate component. It also eliminates the diverter valve and the piping associated with connecting the boiler and diverter valve to the system.

As with the other antifreeze-based systems, solar energy is added to the storage tank through the lower heat exchanger coil.

The modulating/condensing burner and heat exchanger assembly operate as necessary to maintain the top of the storage tank at an adequate temperature to supply domestic hot water whenever required (not necessarily 24/7). At other times, such as night setback periods, the temperature at the top of the storage tank may be allowed to drop based on outdoor reset control logic.

The position of the burner/heat exchanger assembly within the tank encourages temperature stratification and minimizes heating of the lower portion of the tank to minimize losses in collector efficiency.

The water in the storage tank is not potable water. It's the same water that circulates through the panel radiators during space heating. This allows the tank to be constructed of standard steel (rather than stainless steel or standard steel with glass lining to hold potable water).

Domestic water is instantaneously heated as it is drawn through the system. A flow switch closes its contacts whenever cold domestic water is drawn into the external brazed plated heat exchanger. These contacts turn on a small circulator (P1), which creates flow through the tank side of this heat exchanger.

Brazed plate heat exchangers have very small volume and low thermal mass relative to their heat transfer surface area. They can begin heating potable water in one or two seconds after flow is initiated. An anti-scald mixing valve protects against high water temperatures being sent to the fixtures. As soon as hot water flow stops, so does circulator (P1).

Very little domestic hot water is held in the heat exchanger. This reduces the potential for legionella. The heat exchanger can also be removed and serviced if ever necessary.

The heated water at the top of the tank provides thermal mass for a stable supply of heat to the heat exchanger.

Figure 4-8

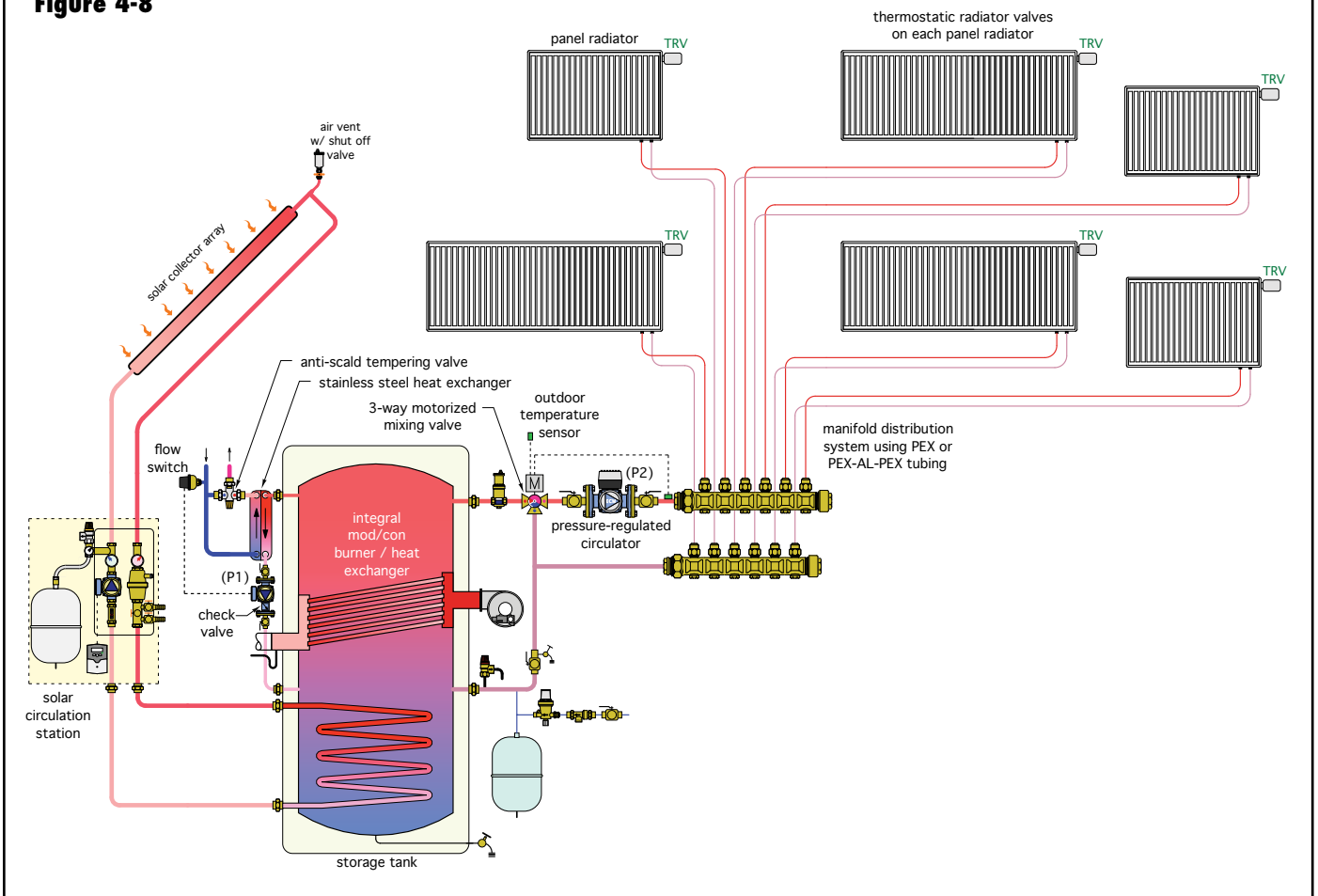

As the tank's temperature begins to drop, the burner fires to maintain a suitable temperature at the top of the tank for sustained domestic hot water delivery.

The thermal mass at the top of the tank also stabilizes a highly zoned space heating distribution system. In figure 4-8, this distribution system consists of a manifold station supplying individually controlled panel radiators. Each radiator has its own thermostatic valve to control heat output. This allows for room-by-room zone control. A variable-speed, pressure-regulated circulator (P2) automatically varies its speed in response to radiator valve modulation.

USING A POOL AS A HEAT DUMP:

The system shown in figure 4-9 is an extension of antifreeze-based system #2, and includes a provision to dump excess heat from the storage tank to a swimming pool.

The extremely large thermal mass represented by the pool can accept a significant amount of heat while only raising a few degrees Fahrenheit in temperature.

This system would treat domestic water as its priority load, routing solar-derived heat to the tank whenever possible. The space heating portion of the system would operate as described for antifreeze-based system #2.

If the temperature at the top of the storage tank reached a user-selected maximum limit, the heat dump subsystem would come into operation. In this system, the following sequence takes place: 1) The diverter valve routes the hot antifreeze solution returning from the collectors to the pool heat exchanger. 2) The flow switch detects this flow and turns on the pool filter pump (if it is not already operating). 3) Heat is now transferred to the pool.

Since the space heating portion of this system is unlikely to operate during warm weather, a significant percentage of the collected solar energy will likely be routed to the pool.

For outdoor pools not used in winter, designers must provide a means of disabling the pool heating mode, and direct any excess energy to an alternative heat dump.

Figure 4-9

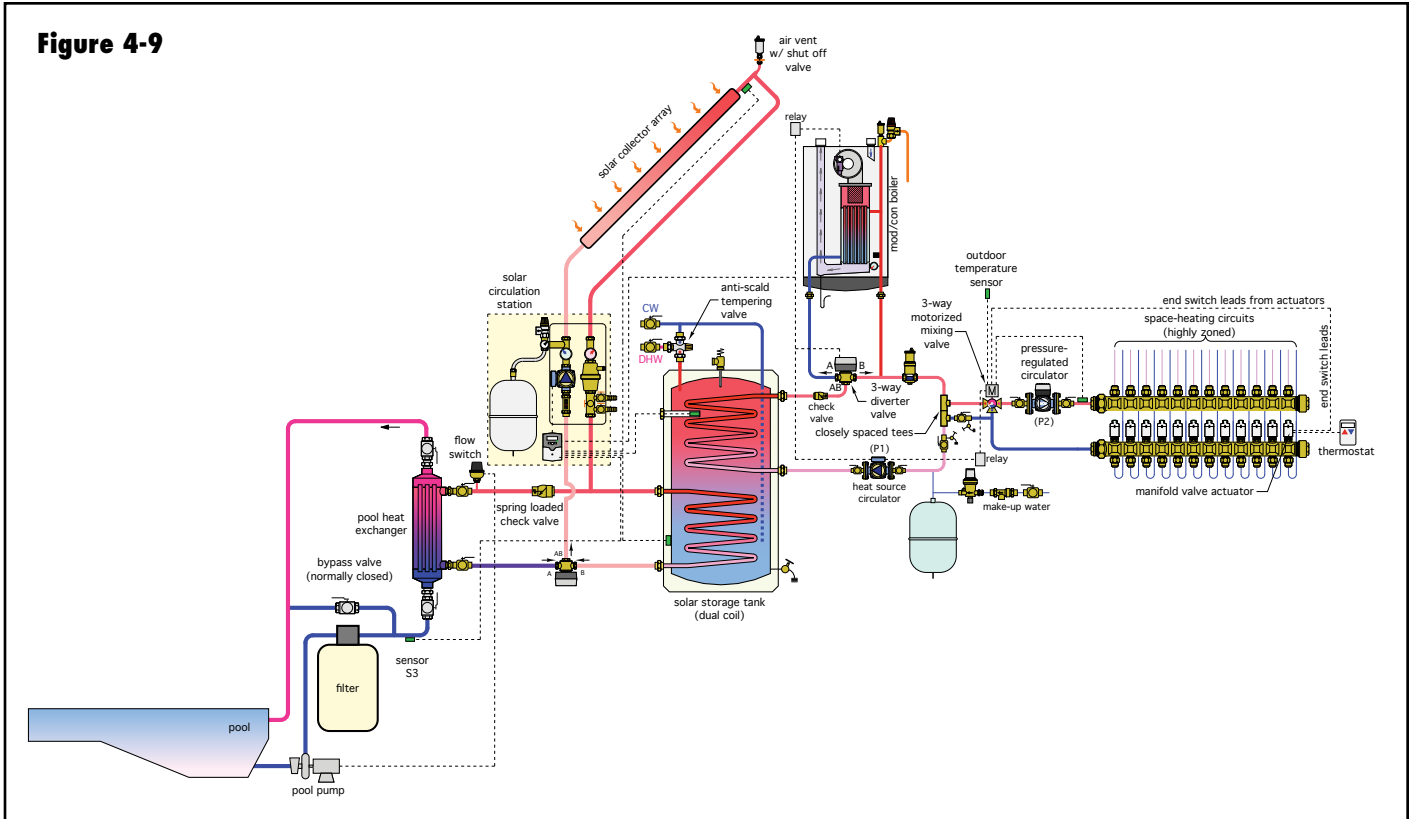

5. DRAINBACK SOLAR COMBISYSTEMS

Drainback systems are the most common alternative to antifreeze-based solar thermal systems. There are many ways to configure drainback combisystems, depending on the heating distribution system used, the percentage of the load to be supplied by solar energy and the type of auxiliary heat source used.

Whenever they are not operating, drainback systems allow water from the collector array and piping outside heated space to drain back to a tank located within heated space. This action requires only gravity and properly sloping piping components. It does not rely on devices such as solenoid valves or vacuum breakers, and as such is highly reliable.

This section discusses several systems that show a wide variety of concepts. The systems are assumed to be for residential applications. However, most can be scaled up for commercial installations.

ADVANTAGES OF DRAINBACK SYSTEMS:

Perhaps the most apparent advantage of a drainback system is the elimination of antifreeze fluids. This, in turn, implies several other benefits, including:

- Antifreeze solutions require a heat exchanger between the collector subsystem and the water in the remainder of the system. Beside the fact that heat exchangers can add significant cost to the system, they also induce a performance penalty. All heat exchangers require a temperature differential to drive heat from their “hot” side to their “cool” side. In solar collection subsystems, the temperature differential shows up as an increase in collector inlet temperature relative to the water temperature near the bottom of the storage tank. This decreases collector efficiency. The magnitude of this performance penalty depends on the size of the heat exchanger. Larger, more expensive heat exchangers reduce the penalty, but never completely eliminate it. Appendix B gives information for estimating the thermal performance penalty associated with a heat exchanger between the collector array and storage tank.
- Eliminating antifreeze also eliminates the annual fluid testing, and thus reduces system owning cost.
- The collectors in a drainback combisystem do not contain fluid when they stagnate. A power outage, control failure or other condition that stops the collector loop circulator results in the water draining back from the collectors and exposed piping. This minimizes internal stresses on the collector relative to systems in

which the fluid remains in the collector or flashes to vapor during stagnation.

- Because the collectors in a drainback system “dry stagnate,” there is no need for a heat dump provision. This is especially relevant to combisystems, which often have larger collector arrays compared to DHW-only systems, and thus have increased potential for warm weather stagnation due to the storage tank reaching a maximum temperature setting.
- Many drainback systems eliminate the need for an expansion tank in the system. The air volume that accommodates drainback water, if properly sized, can serve as the expansion tank for the system.

DISADVANTAGES OF DRAINBACK SYSTEMS:

- All piping to and from the collector array, and in some cases the collectors themselves, must be sloped to ensure proper drainage. A minimum pitch of 1/4-inch vertical drop per foot of horizontal run is recommended. The absorber plates used in some collectors ensure that they will drain completely. Other collector designs may require that the entire collector array be sloped to ensure complete drainage (see figure 5-1). Verify that any collectors being considered for a drainback system are approved and warranted for this application.

It's also possible to slope half the collectors in one direction and half in the other as shown in figure 5-2. In this case, the supply piping penetrates the roof at the midpoint between the two banks of collectors. Return piping penetrates the roof at the upper outside corners of each bank and is joined together under the roof deck.

There can be no low points in any piping connecting the collector array with the storage tank. Any low points can interfere with air reentering the collectors, or create a “trap” that could eventually freeze and burst the pipe.

Designers should also ensure that any “downslope dead ends” (see figure 5-1) are detailed so that water will not puddle across the diameter of the piping. In general, such dead ends should be kept as short as possible.

Collectors with an integral sensor well are preferred for drainback applications. This detail allows the sensor to closely track absorber plate temperature without relying on convection of fluid within the collector. Strapping a sensor to outlet piping, as is commonly done with systems using antifreeze solutions, will delay the control response. Figure 5-3 shows an example of an absorber plate with integrated sensor well.

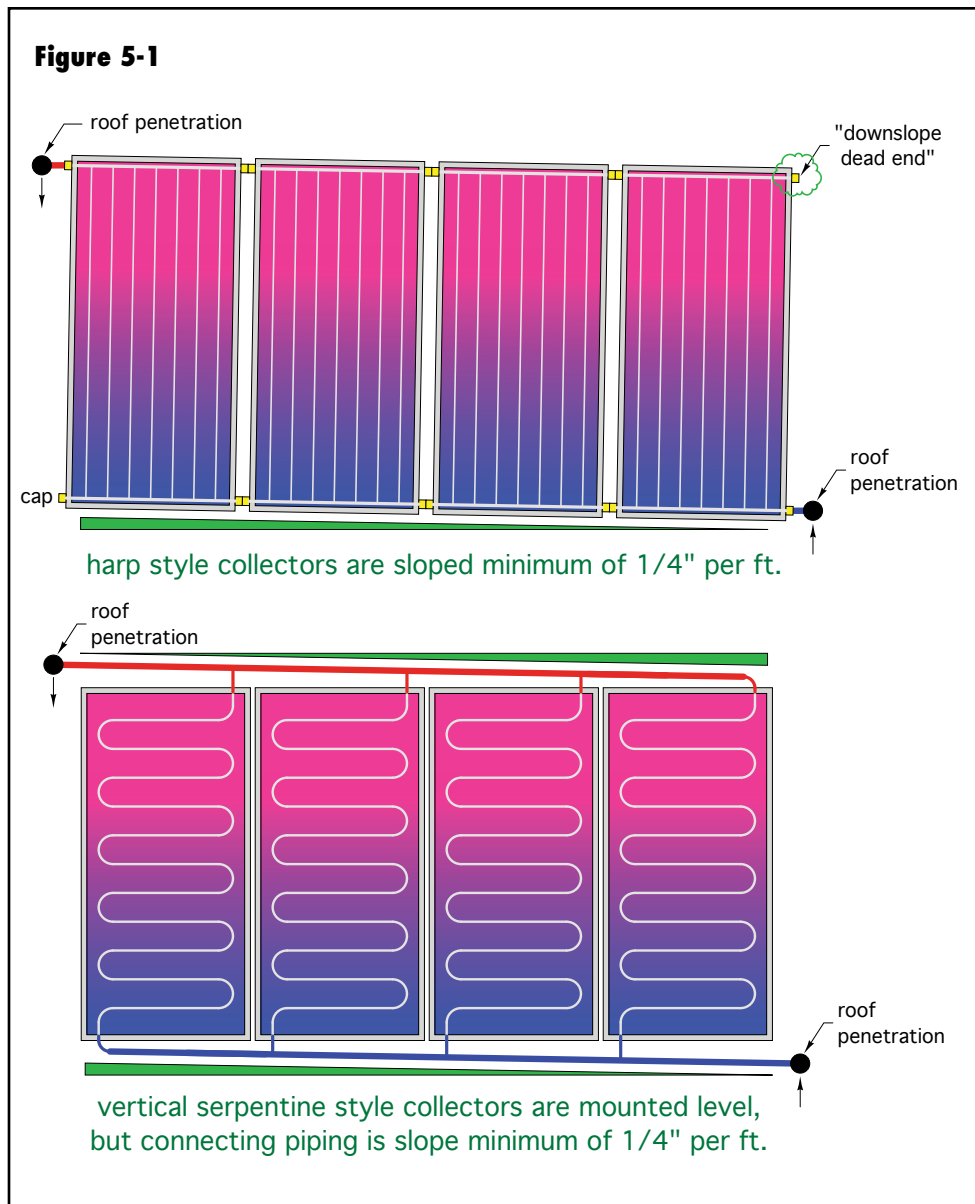

Figure 5-2

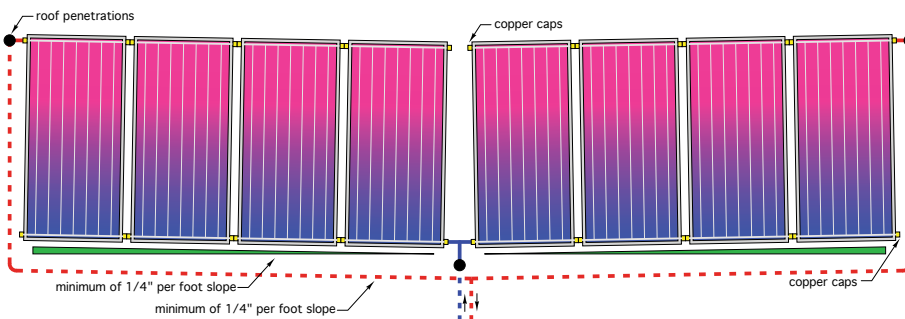
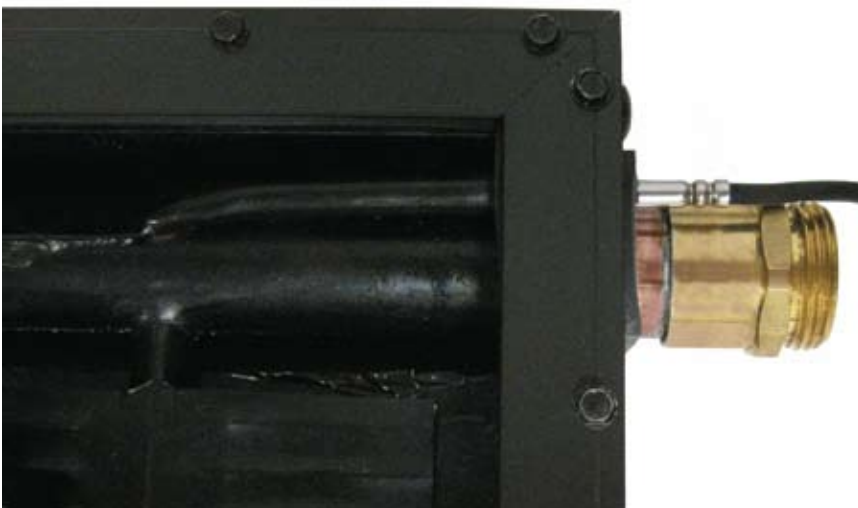

photo courtesy of Radiant Engineering

Figure 5-3



OPEN-LOOP VS. CLOSED-LOOP DRAINBACK SYSTEMS:

As is true with hydronic heating, drainback systems can be designed as either “open-loop” or “closed-loop” systems, as shown in figure 5-4.

Open-loop drainback systems use a non-pressurized storage tank. The air above the water is always at atmospheric pressure.

Non-pressure rated tanks are usually less expensive per gallon of storage than pressure-rated tanks. They can often be assembled on site. Some use an insulated structural “shell” to support a flexible EPDM rubber liner that contains the water. Others are constructed of molded polypropylene. All piping connections to such tanks usually penetrate the tank wall above the water line to minimize any chance of leakage.

Because the water in an open-loop system is in direct contact with the atmosphere, it will always contain dissolved oxygen molecules. All piping components must therefore be suitable for contact with this “oxygenated” water. Circulators must be of stainless steel, bronze or polymer construction. All piping, fittings and valves must also be corrosion-resistant. Copper piping along with copper or brass fittings and valves are common. Stainless steel and high-temperature composite or polymer materials are also a possibility, provided they are rated to withstand the potentially high temperatures within the solar collector circuit.

Open-loop systems will experience some water loss due to evaporation. The water level in the tank should be checked monthly using the sight glass or dip stick. Water can be easily added to the system through the hose bib valve at the bottom of the collector supply piping.

Figure 5-4

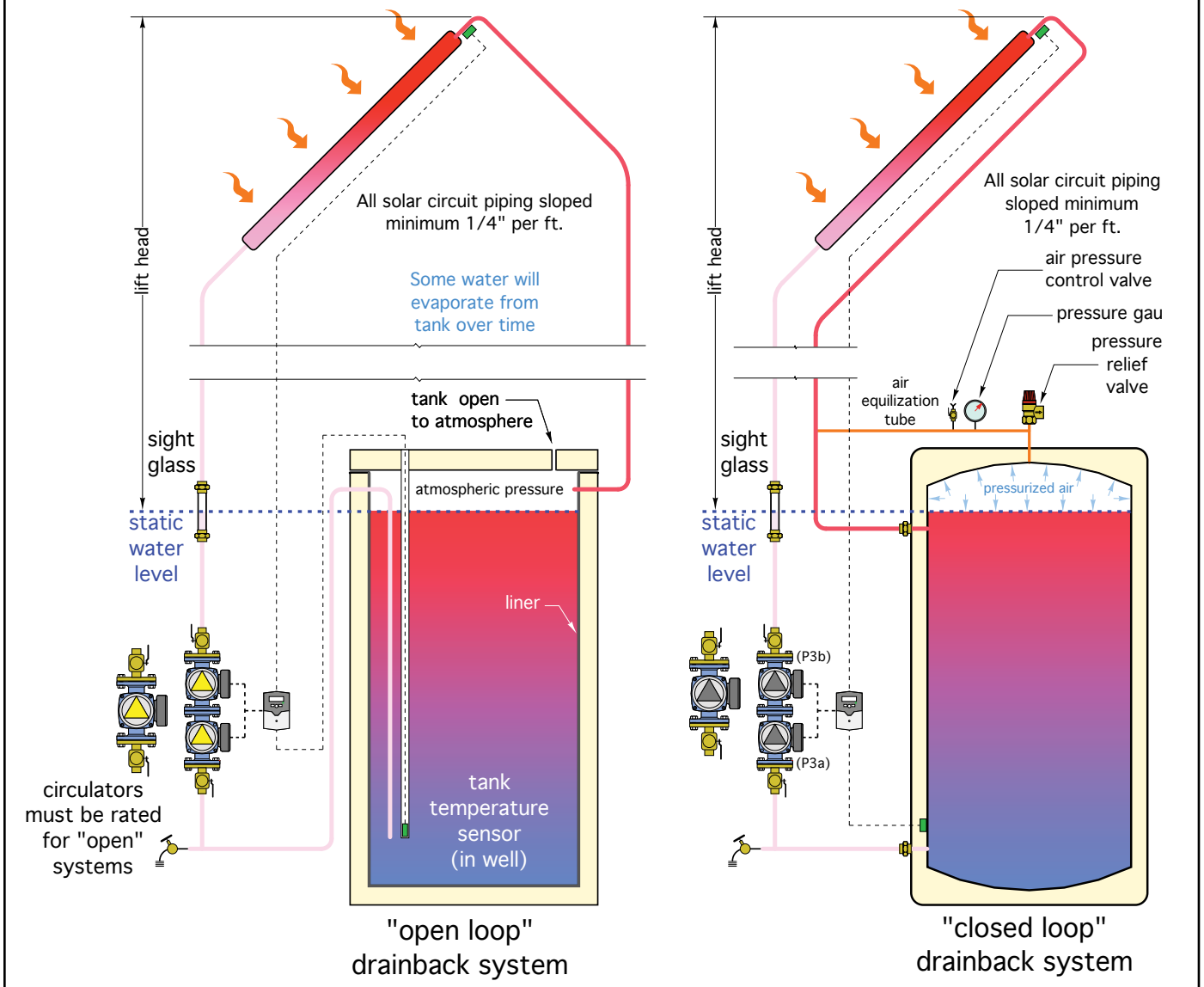

Most of the drainback combisystems to be presented in this section are closed-loop systems. The water and air they contain is, for all practical purposes, sealed into the system. Like other closed-loop hydronic systems, they can use cast iron circulators and contain steel components. The dissolved oxygen in the initial water and air volume will react with any ferrous metal in the system, forming a very light and essentially insignificant oxide film. At that point, the water is neutralized and will not continue to oxidize metals.

Closed-loop systems can also experience very minor water losses over a period of time due to weepage at valve packing or circulator flange gaskets. Some of the dissolved air in the cold water used to fill the system will

also be removed and vented over time. These effects will cause a minor drop in the system's static water level over time. Small amounts of water can be manually added to the system through the lower hose bib valve to correct for these losses.

An automatic make-up water assembly should NEVER be connected to this type of system. Doing so, especially in systems with high-performance air separating/venting devices, will eventually replace the air in the system with water. Over time this will eliminate the necessary air space for proper drainage and could eventually lead to freezing of water-filled piping or collectors exposed to outdoor temperatures.

Figure 5-5

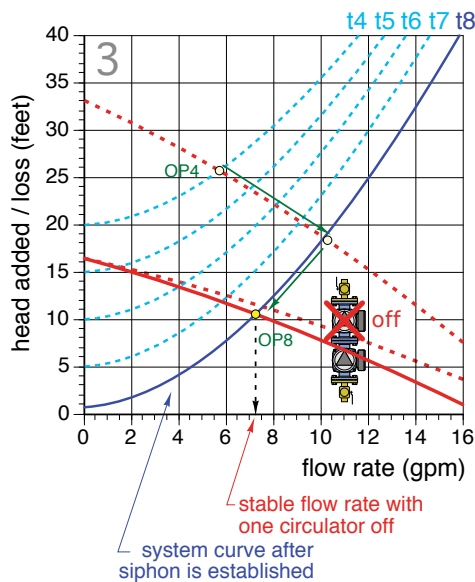
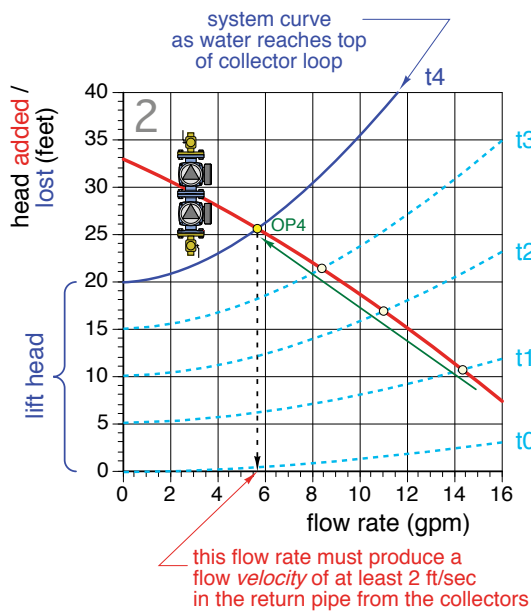
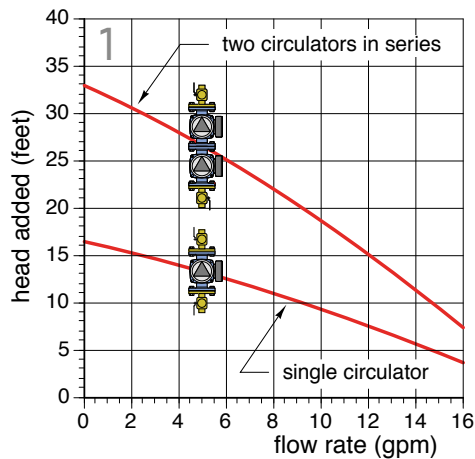

OPERATION OF A DRAINBACK SYSTEM:

The solar heat collection cycle in a drainback system is controlled the same way as that in an antifreeze-based system. When the collector sensor reaches a temperature a few degrees above that of the tank sensor, the circulator(s) are turned on.

A drainback system might contain two circulators in series, or a single “high head” circulator. In either case, the circulator(s) push water up through the piping and collector array. Air is pushed ahead of this water and eventually back to the space at the top of the storage tank. The water level within the tank drops slightly during this process. There is no need of either a high-point air vent (as required in an antifreeze-based system) or a vacuum breaker at the top of the collector circuit.

With proper pipe sizing, the flow velocity in the piping returning from the collector array allows air bubbles to be entrained with the water and returned to the top of the storage tank. As this occurs, a siphon is formed within the return piping. This siphon eventually cancels out most of the initial “lift head” associated with filling the collector array.

Once the siphon is established, it is usually possible to turn off the upper of two series-connected circulators, or reduce the speed of a single high-head circulator, and still maintain adequate flow through the collector array.

The sequence of operation of a “dual-pumped” drainback system using two series-connected fixed-speed circulators is depicted in figure 5-5.

The upper graph shows the effective pump curve of two identical fixed-speed circulators connected in series. It is constructed by doubling the head of the single circulator at each flow rate.

Both circulators are turned on each time the solar energy collection process begins. During the first few seconds of operation, water is lifted upward through the collector supply piping. This causes the system curve to migrate upward along the graph as depicted by the light blue dashed lines labeled t1, t2 and t3 in the upper graph. Notice that these curves steepen as they rise. This is due to the frictional resistance of water flowing through more piping and the collector array as flow approaches the top of the collector circuit.

The dark blue system curve labeled t4 represents the situation as water “rounds the turn” at the top of the collector circuit. The intersection of this system curve and the pump curve for two circulators in series establishes the instantaneous operating point marked as OP4. The flow rate associated with this operating point can be read from the horizontal axis directly below this point. For the example shown in figure 5-5, this flow rate is about 5.7 gallons per minute.

To establish a siphon, the flow rate at operating point OP4 must produce a corresponding flow velocity within the return piping of 2 feet per second or higher. The flow rates necessary for a flow velocity of 2 feet per second in type M copper tubing are shown in figure 5-6.

Water at a flow velocity of 2 feet per second or higher can entrain air bubbles and drag them along. This action eventually rids the return piping of air, displacing it back to the top of the storage tank. At that point, a siphon is established in the return line. Think of the water going down the return pipe as helping “pull” water up the supply pipe. The formation of a siphon causes the system curve to shift downward, as depicted by the light blue curves t4, t5, t6, t7, and finally the dark blue curve t8. In a typical residential drainback system, this sequence may take 30 seconds to perhaps 3 minutes. Depending on the details at the top

A similar solar collection cycle process occurs in systems that use a single speed-controlled high-head circulator. The circulator starts at full speed to quickly push water up through the collector array and establish the siphon. After some period of time, the circulator reduces its speed (based on user programmed settings). The intersection of the circulator’s reduced speed pump curve and the system curves after the siphon has formed determines the stabilized flow rate through the collector array for the remainder of the cycle.

SIPHON LIMITATIONS:

Once a siphon is established within a drainback system, it’s important to maintain it until no further solar energy collection is possible.

Modern controllers, which vary collector circulator speed in response to the difference between the collector temperature and storage tank temperature, have a minimum speed function intended to maintain the siphon under reduced speed operation. If the siphon does break, the collector temperature would rise rapidly (because there is no flow through it). The controller would detect this, and increase circulator speed to reestablish the siphon.

In addition to adequate flow velocity in the collector return piping, siphon stability depends on a relationship between the water’s temperature, its corresponding vapor pressure, and the vertical distance between the top of the collector circuit and the water level in the storage tank.

Tubing	Flow rate to establish 2 ft/sec flow velocity
1/2" type M copper	1.6 gpm
3/4" type M copper	3.2 gpm
1" type M copper	5.5 gpm
1.25" type M copper	8.2 gpm
1.5" type M copper	11.4 gpm
2" type M copper	19.8 gpm
2.5" type M copper	30.5 gpm
3" type M copper	43.6 gpm

of the storage tank, the system’s pressure and the height of the collector array, much of the initial “lift head” is now recovered by the downward “pull” of the siphon.

When the upstream circulator is turned off, the operating point shifts to a final position marked as OP8. This point determines the flow rate the collector array operates at during the remainder of the solar collection cycle. Notice that the flow rate at the stable operating point OP8 is higher than the flow rate through the collectors when the water first passes over the top of the collector circuit with both circulators operating. For the example given, it is about 7.2 gallons per minute.

The solid red pump curve in graph 3 is shifted slightly below the pump curve for the single circulator. It represents the “net” effect of the lower circulator pumping through the volute of the upstream circulator, which is now off.

A conservative estimate for the maximum siphon height that can exist can be made using formula 5-1:

Formula 5-1

$$H_{max} = \left(\frac{144}{D} \right) (P_a + P_{top} - P_v)$$

Where:

- Hmax = maximum siphon height
- D = density of water at maximum anticipated temperature (lb/ft³)
- P_a = atmospheric pressure (psia)
- P_{top} = extra pressurization (above atmospheric) at the top of the collector circuit (psi)
- P_v = vapor pressure of water at maximum anticipated temperature (psia)



The vapor pressure and density of water needed for formula 5-1 can be calculated using the following formulas:

$$P_v = 0.771 - 0.0326 \times T + (5.75 \times 10^{-4}) \times T^2 - (3.9 \times 10^{-6}) \times T^3 + (1.59 \times 10^{-8}) \times T^4$$

$$D = 62.56 + (3.413 \times 10^{-4}) T - (6.255 \times 10^{-5}) T^2$$

Where:

P_v = vapor pressure of water (psia)

D = density of water (lb/ft³)

T = temperature of water (°F)

For example: Determine the maximum siphon height based for water at 200°F in a system at sea level (where $P_a = 14.7$ psia), and where the pressure at the top of the collector circuit is 10 psi above atmospheric pressure.

Solution: The density and vapor pressure of water at 200°F is:

$$D = 62.56 + (3.413 \times 10^{-4}) 200 - (6.255 \times 10^{-5}) 200^2 = 60.1 \text{ lb / ft}^3$$

$$P_v = 0.771 - 0.0326 \times 200 + (5.75 \times 10^{-4}) \times 200^2 - (3.9 \times 10^{-6}) \times 200^3 + (1.59 \times 10^{-8}) \times 200^4 = 11.49 \text{ psia}$$

The maximum siphon height is then calculated:

$$H_{max} = \left(\frac{144}{D} \right) (P_a - P_v + P_{top}) = \left(\frac{144}{60.1} \right) (14.7 - 11.49 + 10) = 31.7 \text{ ft}$$

If the system were installed with a greater vertical drop from the top of the collector circuit to the water level in the storage tank, the water in the return piping would flash to vapor (e.g., boil) and break the siphon.

The maximum siphon height decreases with increasing water temperature, because as temperature increases, the water comes closer to its vapor flash point.

The maximum siphon height can be increased by raising the pressure within a closed-loop drainback system. Increased pressure helps “suppress” water from boiling. This is a significant advantage of a closed-loop pressurized drainback system relative to an open-loop system where no pressurization is possible.

This analysis does not include the effect of frictional pressure drop in the return piping, or the potential effect of adding a flow-restricting device near the end of the return piping to increase pressure in that pipe and thus help suppress vapor flash.

If the height of the building is such that the collector circuit must be taller than the maximum siphon height, a separate drainback tank may be located high in the building to limit the lift head, as shown in figure 5-7.

The lift head is now from the static water level in the elevated drainback tank to the top of the collector circuit. The vertical height of the piping circuit below this water level does not affect lift head.

SIGHT GLASSES:

All drainback systems require a means of verifying the proper water level in the drainback reservoir. This is true when the top of the storage tank serves as the drainback reservoir or if a separate drainback tank is used.

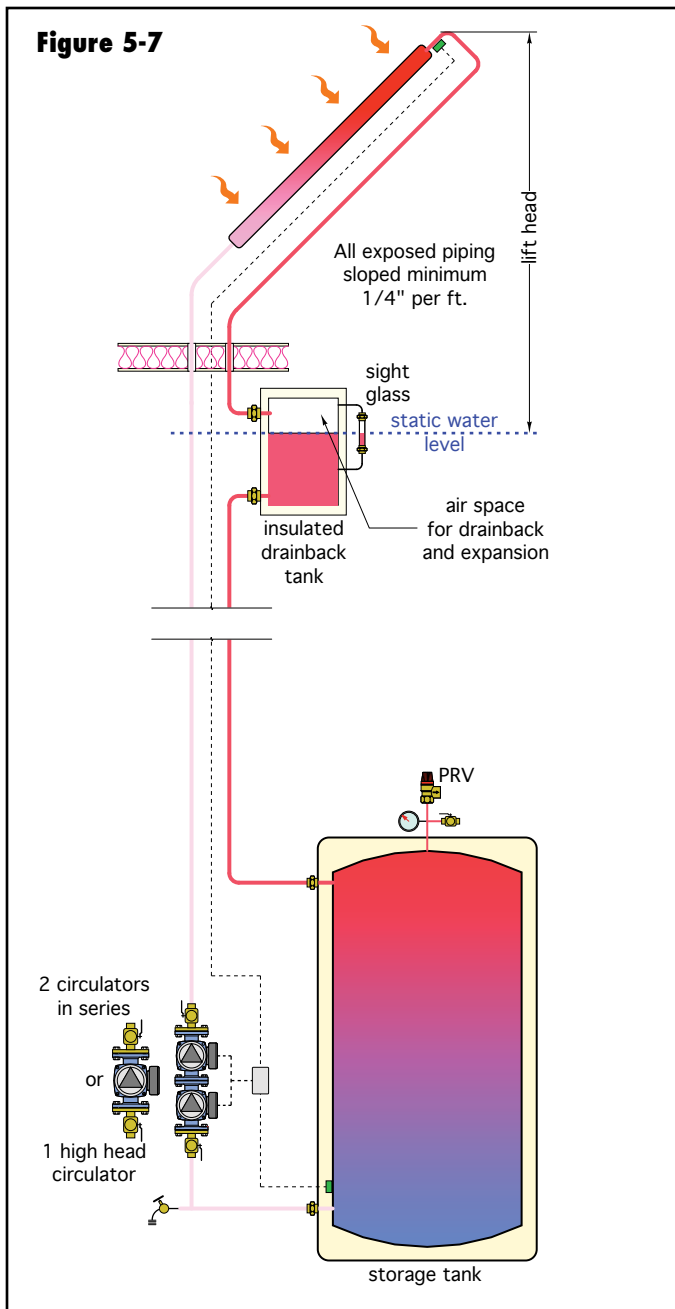

Figure 5-8



Image courtesy of Hot Water Products, Inc.

In some systems, particularly open-loop systems using translucent polymer storage tanks, it may be possible to see the water level as a shadow line on the tank wall or by looking into the tank through a small opening at the top. A “dip stick” is another possibility for checking water level in such systems.

In a closed-loop pressurized system, a “sight glass” is the common solution for checking water level (see figure 5-8). The sight glass can be mounted within the upgoing collector supply piping, directly to the storage tank, or to two other piping locations on the same side of the collector circuit — one above and one below the static water level. In all cases, the water in the system seeks a single level when the collector circulators are off. It is advisable to place the sight glass where it can be easily accessed.

Some sight glasses are made of temperature resistant glass, others may use temperature resistant translucent polymers. It is even possible to use a piece of translucent PEX tubing as a sight “glass” provided it is operated within its rated temperature/pressure range.

It is suggested that the sight glass tube be a minimum of 12 inches long and centered on the desired static water level in the tank. Longer sight glasses will obviously allow more variations in water level to be detected. Sight glasses should also be serviceable. The transparent or translucent tube itself may accumulate a film over time and require removal for cleaning or replacement. Install isolating ball valves to ensure such service is possible without need of draining the storage tank.

TANK PIPING CONNECTIONS:

There are several ways to detail the piping at the top and bottom of a drainback tank. As previously mentioned, most open-loop drainback systems bring all piping connections through the top or high side wall of the tank, and above the static water level. This reduces the possibility of leakage as gaskets at such connecting points age.

In open-loop systems, an inverted U-tube is used to draw water from the lower portion of the tank to the collector circulator(s) (see figure 5-4). The top of this U-tube should

be kept as close to the top of the tank as possible. It should also use generously sized piping to minimize frictional head loss. The inverted U-tube is “primed” with water by closing an isolation flange on the collector circulator and adding water at a high flow rate through the hose bib valve below the collector circulator. The objective is to displace air within the upper portion of the U-tube. Once this is accomplished, the water will remain in place when the circulators are off. A valve can be added to the top of the U-tube to minimize the amount of air needing to be displaced at priming; however, be sure this valve is tightly sealed at all other times to maintain the priming water in place. Do not place a float-type air vent or vacuum breaker at the top of the inverted U-tube. Since this portion of the piping is under negative pressure relative to the atmosphere, either of these devices will allow air into the system.

There are also numerous variations in how the return piping from the collector array attaches to the tank. It is crucial that all such connections allow air to flow backward into the return piping at the onset of the drainback process. It is also preferable that the water enters the storage tank horizontally. This minimizes disruption of the vertical temperature stratification within the tank.

If the return piping enters the drainback tank above the operating water level, there will be a slight “water fall” sound created by the water falling from the end of the pipe to the water level in the tank. Although a matter of opinion, a drop of perhaps a few inches within a well insulated tank, located in a mechanical room away from primary living space, should not create objectionable sounds.

If the return pipe enters the tank below the operating water level, a separate air equalization tube must be used as shown in some schematics within this section. Some of the flow returning from the collectors may pass into this tube as the system operates. However, momentum will carry most of the flow past the tee where the air equalization tube connects to the collector return piping, and thus most of the water will enter below the water level in the tank.

DRAINBACK COMBISYSTEM #1:

The first complete drainback combisystem we’ll discuss is shown in figure 5-9. This system may look familiar to those who have read section 4. It uses the same boiler, near-boiler piping and distribution system concept as shown with antifreeze-based system #2. The only difference is that a drainback solar subsystem is now in place.

Figure 5-9

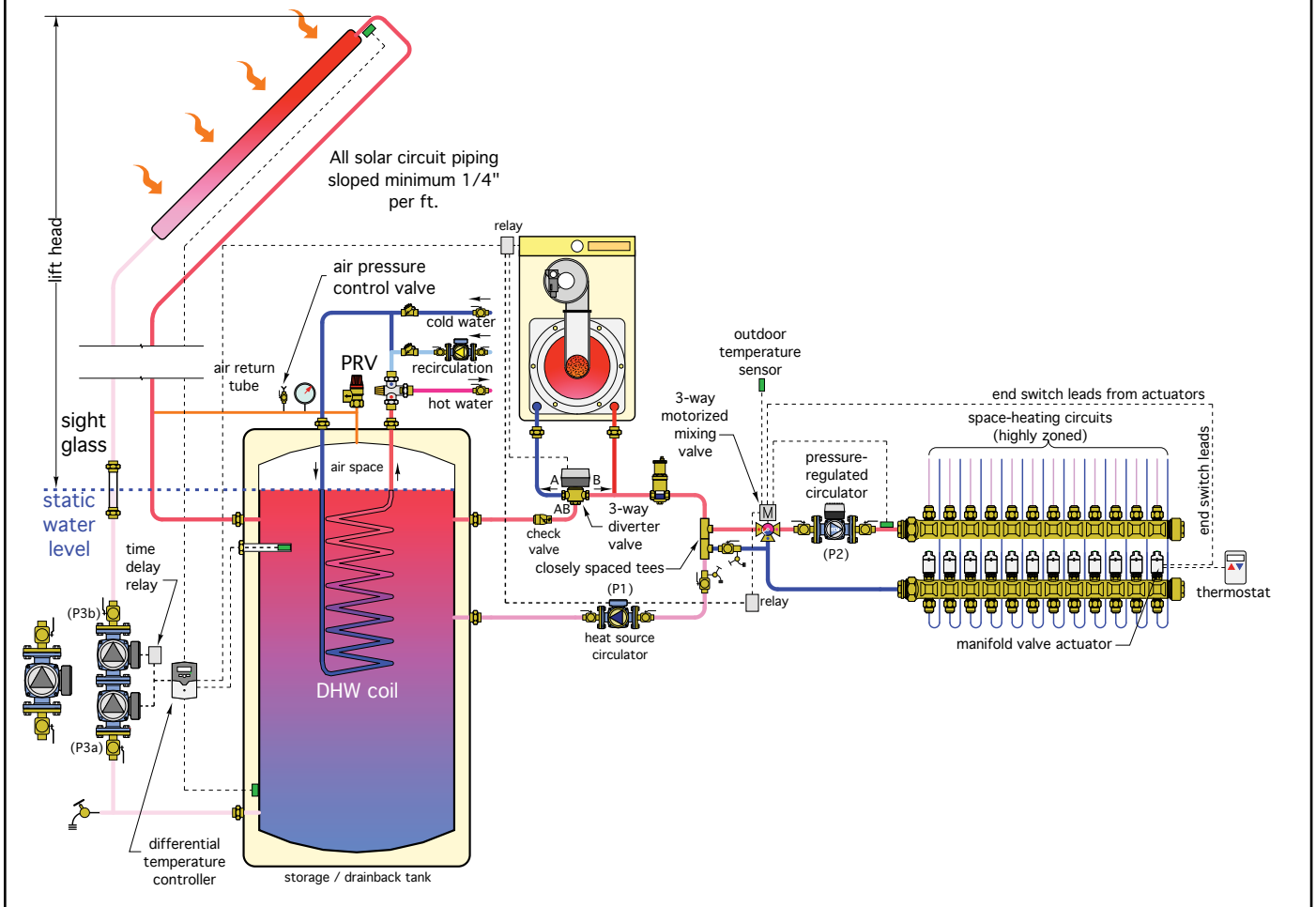

This is a slightly pressurized closed-loop drainback system. The same water that flows through the collector array can also flow through the space heating distribution system, as well as through the boiler when necessary. No heat exchangers are required between these parts of the system.

The suspended coil near the top of the tank is for heating domestic hot water. It is constructed of either stainless steel or copper, and in some tanks, can be removed through a large flanged opening at the top of the tank.

The boiler operates as necessary to maintain a suitable minimum temperature at the top of the storage tank. This ensures that domestic hot water is always available upon demand. Temperature stratification within the tank minimizes heat migration to the lower portion of the tank.

The solar system controller used in this system provides two outputs. One operates the collector circulator(s). The other is used to operate the boiler and 3-way diverter

valve as necessary to maintain a suitable minimum temperature at the top of the storage tank.

If two series-connected circulators are used for the collector circuit, a separate time delay relay can be used to turn the upper circulator off once the siphon is established in the return piping.

Whenever the solar system controller determines the top of the tank requires heating, it fires the boiler and powers on the 3-way diverter valve so flow passes from the valve's "AB" port through its "A" port, and on through the boiler. The same signal also turns on the heat source circulator (P1).

A call for space heating comes from any zone thermostat, which powers up a manifold valve actuator. When the actuator reaches the end of its travel, an internal end switch closes to send 24 VAC power to the mixing valve controller. This 24 VAC signal also powers the coil of a relay (R1), which applies 120 VAC to operate circulator

(P1) and (P2). The mixing valve controller operates on outdoor reset logic to maintain the ideal supply temperature to the distribution manifold.

If the boiler is operating during the call for space heating, some of its heat output will be extracted at the closely spaced tees that provide hydraulic separation between circulators (P1) and (P2). The remainder of its output will be absorbed into the water at the top of the storage tank.

If the boiler is not operating during the call for heat (which is the expected situation after a significant period of solar energy collection), the 3-way diverter valve routes flow through its "B" port, bypassing the boiler. Heated water is supplied directly from the storage tank to the closely spaced tees. The motorized mixing valve draws in the hot water it needs to control the supply temperature to the space heating distribution system.

Notice that there is no automatic make-up water assembly used on this system. Likewise, there is no separate expansion tank. Minor water losses over time can be monitored at the sight glass, and "made up" by manually adding water through a low-point hose bib valve. The air reservoir at the top of the storage tank, if properly sized, can serve as the system's expansion tank.

This system uses the thermal mass at the top of the storage tank to "buffer" the space heating distribution system. This is especially desirable if the distribution system is highly zoned.

DRAINBACK COMBISYSTEM #2:

Another combination of subassemblies has been used to build the combisystem shown in figure 5-10.

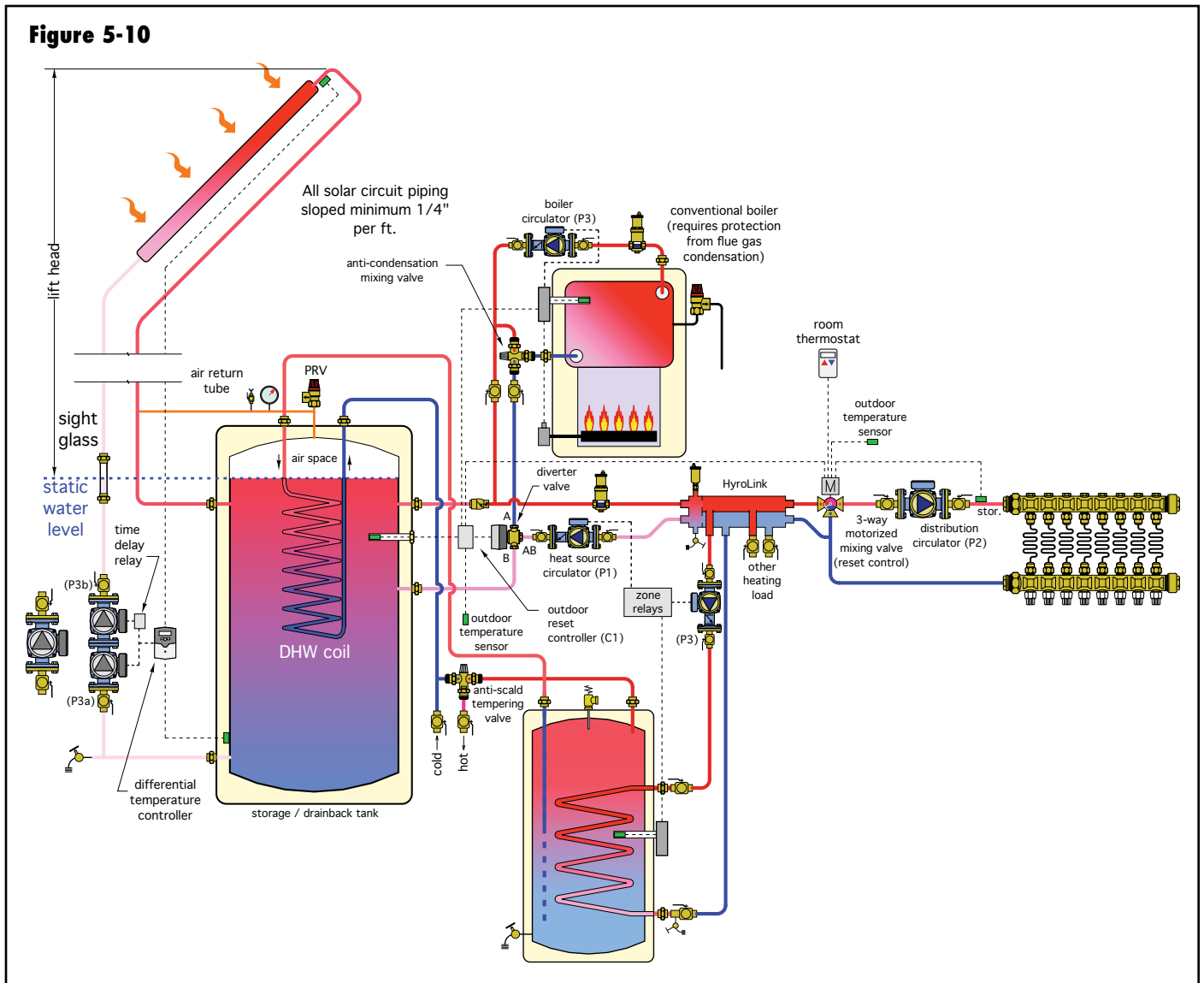

The solar collection process operates the same way as in drainback combisystem #1. However, in this system, the differential temperature controller only handles the solar collection function. Other control devices manage the heat source selection, distribution of heat and domestic water heating. Many of these other controls are common to other types of hydronic systems.

This system uses two tanks: solar storage and a conventional indirect water heater. No auxiliary heat from the boiler is ever sent to the solar storage tank. This allows that tank to remain as cool as possible, and thus maximizes solar collector efficiency.

Heat in the solar storage tank is transferred to cold domestic water through the suspended coil heat exchanger. This allows the solar storage tank to provide some domestic water preheating even when it is relatively cool. However, during or after a period of solar energy collection, this coil may provide the full temperature rise required. If not, supplemental heat is supplied by the boiler through the HydroLink and then through the heat exchanger of the indirect water heater.

For the system shown, a call for spacing heating comes from the room thermostat, which supplies 24 VAC power to the 3-way motorized mixing valve, as well as the outdoor reset controller (C1). The mixing valve begins regulating the supply temperature to the distribution system based on its settings.

The outdoor reset controller (C1) compares the temperature at the top of the storage tank to a calculated “ideal” supply water temperature for the space heating subsystem.

An example of the outdoor reset control function is shown in figure 5-11. The “target” temperature is represented by the solid gray sloping line on this graph, and is a function of outdoor temperature and the current controller settings. The blue dashed line below the target temperature line indicates the temperature at which the contacts on the outdoor reset controller close. The red dashed line above the target temperature line indicates the temperature where these contacts open.

For example, if the outdoor temperature is 30°F, the calculated target temperature shown in figure 5-1 is 92.5°F. The lower dashed line indicates that the contacts close if the temperature at the tank top sensor is 90°F or less. The upper dashed line indicates that the contacts open if that temperature is 95°F or more.

With these settings, if the outdoor temperature equals 30°F and the temperature at the top of the solar storage tank is 90°F or less, the controller determines that the solar storage tank is too cool to supply the heating distribution system. It then closes its contacts to power on the diverter valve, allowing it to change position and route flow through the boiler. When the diverter valve has completed its movement, an end switch within the valve’s

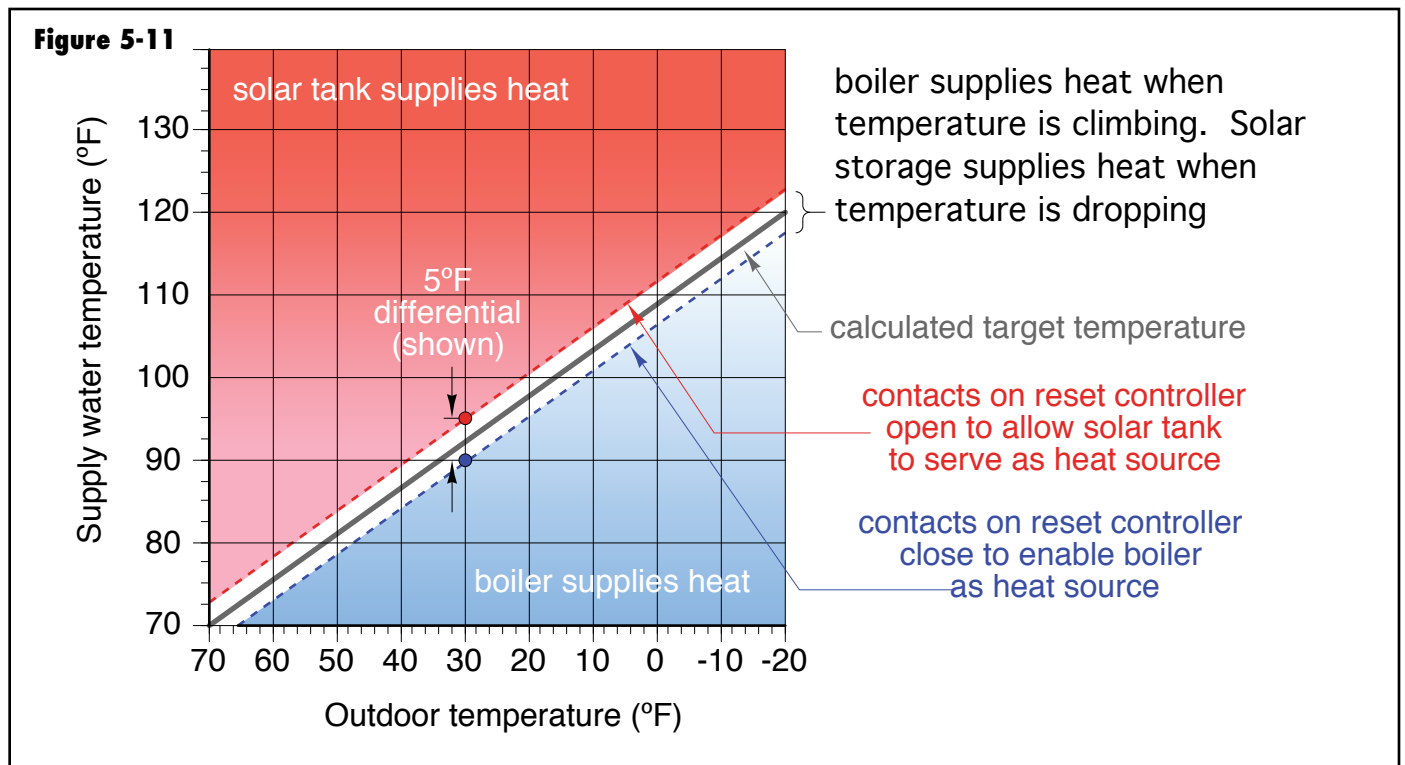
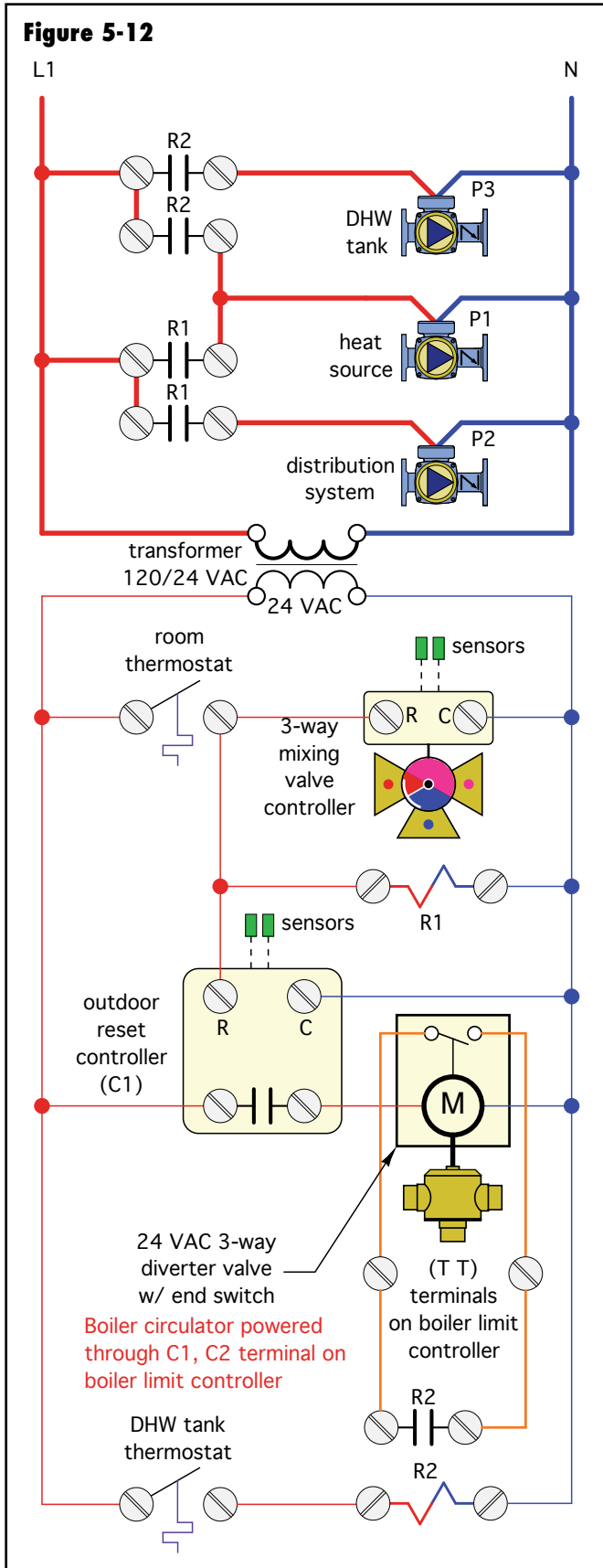

Figure 5-12



actuator closes to operate the boiler and the boiler circulator. Hot water is then supplied to space heating through the HydroLink, and eventually the 3-way mixing valve.

If the temperature at the top of the auxiliary tank is 95°F or higher, the outdoor reset controller (C1) allows the solar storage tank to serve as the heat source for the distribution system.

If the solar storage tank is serving as the heat source, it continues to do so until the tank sensor temperature drops to 90°F, at which point the system automatically switches to the boiler as the heat source.

If the boiler is serving as the heat source, it continues to do so until the tank temperature climbs above 95°F (from additional solar gain). At this point, the solar storage tank again becomes the heat source.

Keep in mind that these temperatures change based on the current outdoor temperature. The slope of the reset line, as well as the differential of the outdoor reset controller, can be adjusted to suit the type of heat emitters and auxiliary heat source used in the system. This simple method of switching between heat sources allows the solar storage to be utilized to the lowest possible temperature compatible with the heat emitters. This improves collector efficiency and increases the total solar energy gathered over the heating season.

A conventional boiler is shown in this system. As in other hydronic systems serving low-temperature distribution systems, such boilers require protection against sustained flue gas condensation. This is accomplished using a thermostatic mixing valve to monitor the inlet temperature to the boiler and boost it when necessary by blending in hot water from the supply side of the boiler.

A partial wiring schematic showing how the system operates (other than solar energy collection function) is shown in figure 5-12.

DRAINBACK COMBISYSTEM #3:

Both of the previous drainback designs use a suspended coil heat exchanger in the solar storage tank for domestic water preheating. While certainly plausible, this approach limits potential tank suppliers, especially if the size of the tank or its internal heat exchanger is “non-standard.”

The serviceability of an internal heat exchanger over the life of the system is also a consideration. Some tanks allow the internal heat exchanger to be lifted out through a large flange at the top of the tank if ever necessary. Others do not allow any access to the internal heat exchanger. The

Figure 5-13

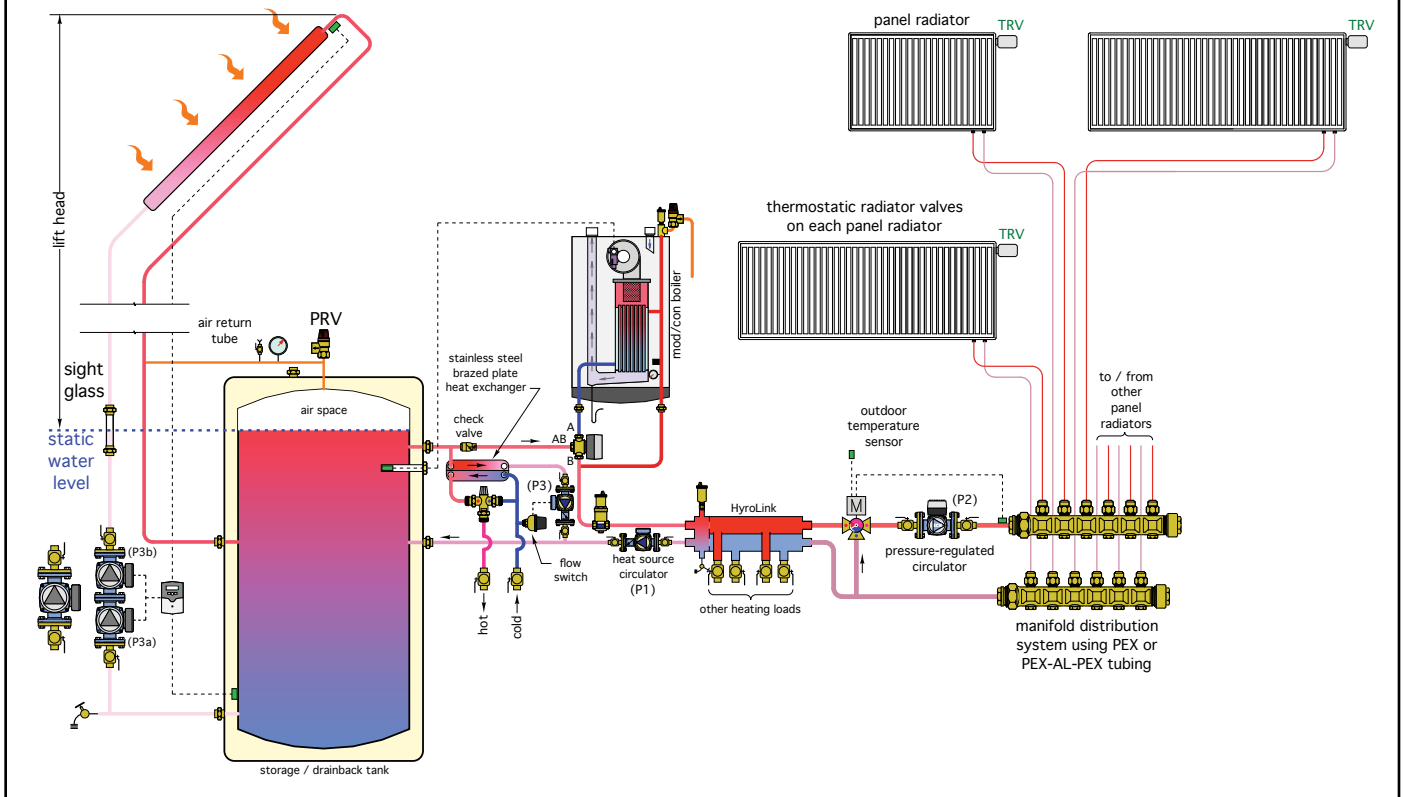

latter present few options if a leak, corrosion or scaling ever develop to the point where the coil can no longer function.

The approach used in figure 5-13 eliminates the need for this internal heat exchanger.

Solar collection is handled by a closed-loop, slightly pressurized drainback subsystem. The storage tank is a simple, carbon steel vessel with no internal components or special detailing.

The boiler operates as necessary to maintain the top of the storage tank at a suitable minimum temperature for domestic hot water delivery. When a hot water fixture opens, a flow switch detects the flow of cold domestic water and turns on the small circulators (P3). This moves heated water from the top of the storage tank through one side of a stainless steel brazed plate heat exchanger. Cold domestic water flows through the other side of this heat exchanger.

Because the plate heat exchanger has very little water content relative to its plate area, it warms and transfers heat within a second or two after the flow of hot water begins. Thus, domestic hot water is produced “instantaneously” upon demand. The thermal mass of hot

water in the storage tank allows for stable DHW delivery. This approach also minimizes the quantity of domestic hot water held in the system at any time reducing the potential for legionella.

Space heating is provided from a manifold station serving panel radiators (sized for operation at low supply water temperature). Each panel radiator is controlled by its own thermostatic radiator valve. A variable-speed pressure-regulated circulator (P2) modulates its speed as necessary to maintain a constant differential pressure across the manifolds as zone circuits open and close.

A HydroLink serves to hydraulically isolate the space heating distribution system and two other potential heating zones (served from the bottom connections of the HydroLink) from the heat source circulator (P1).

This system provides the benefits of a single storage tank, elimination of heat exchangers between the solar subsystem and space heating circuits, buffering for a highly zoned distribution system, instantaneous domestic water heating and an easily serviced external heat exchanger for domestic water heating.

Figure 5-14 shows the original system schematic at the top, and its operating mode while supplying domestic hot

Figure 5-14

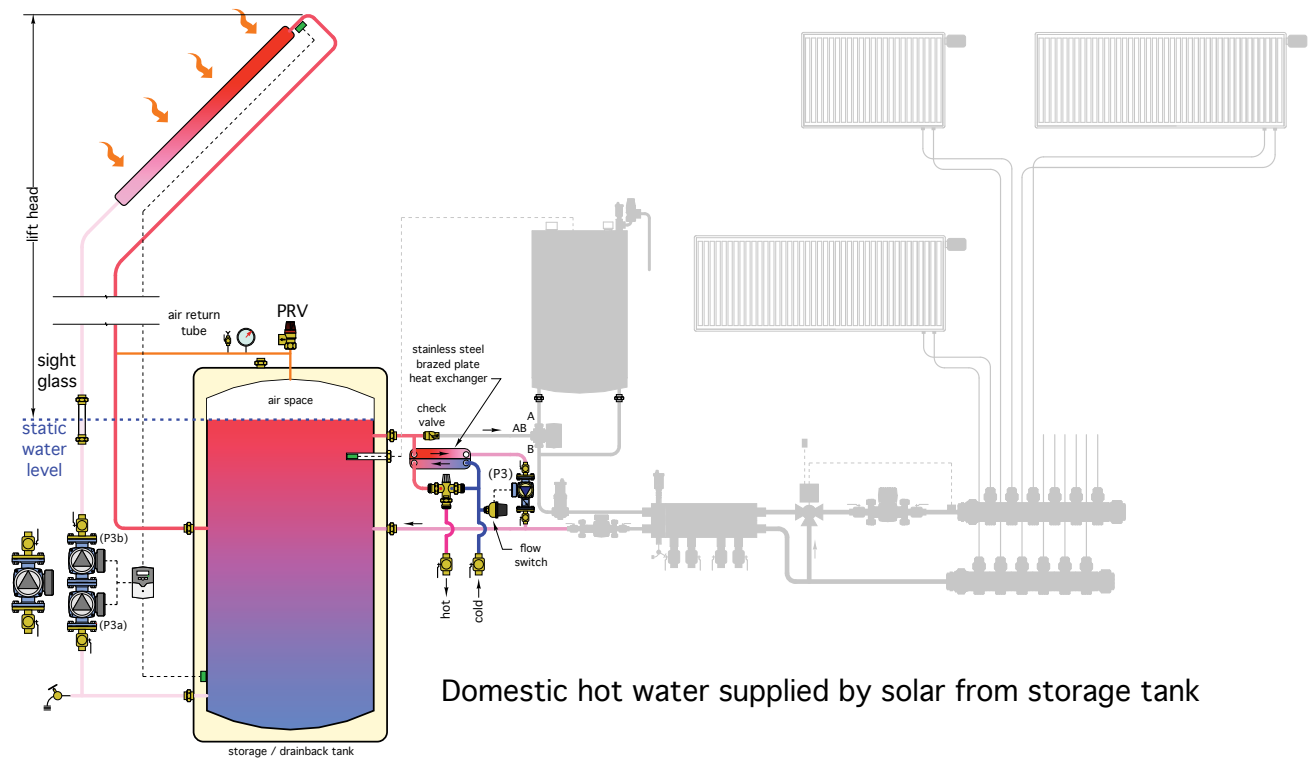
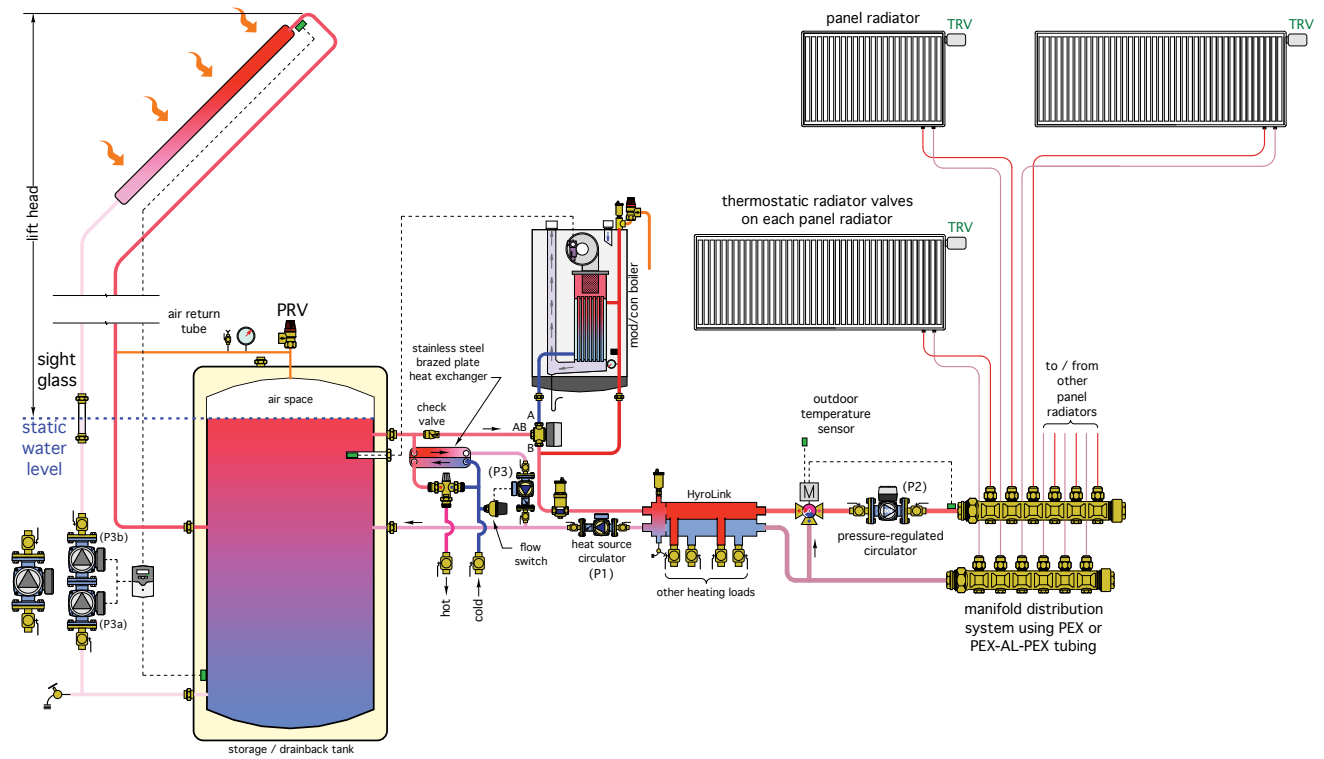
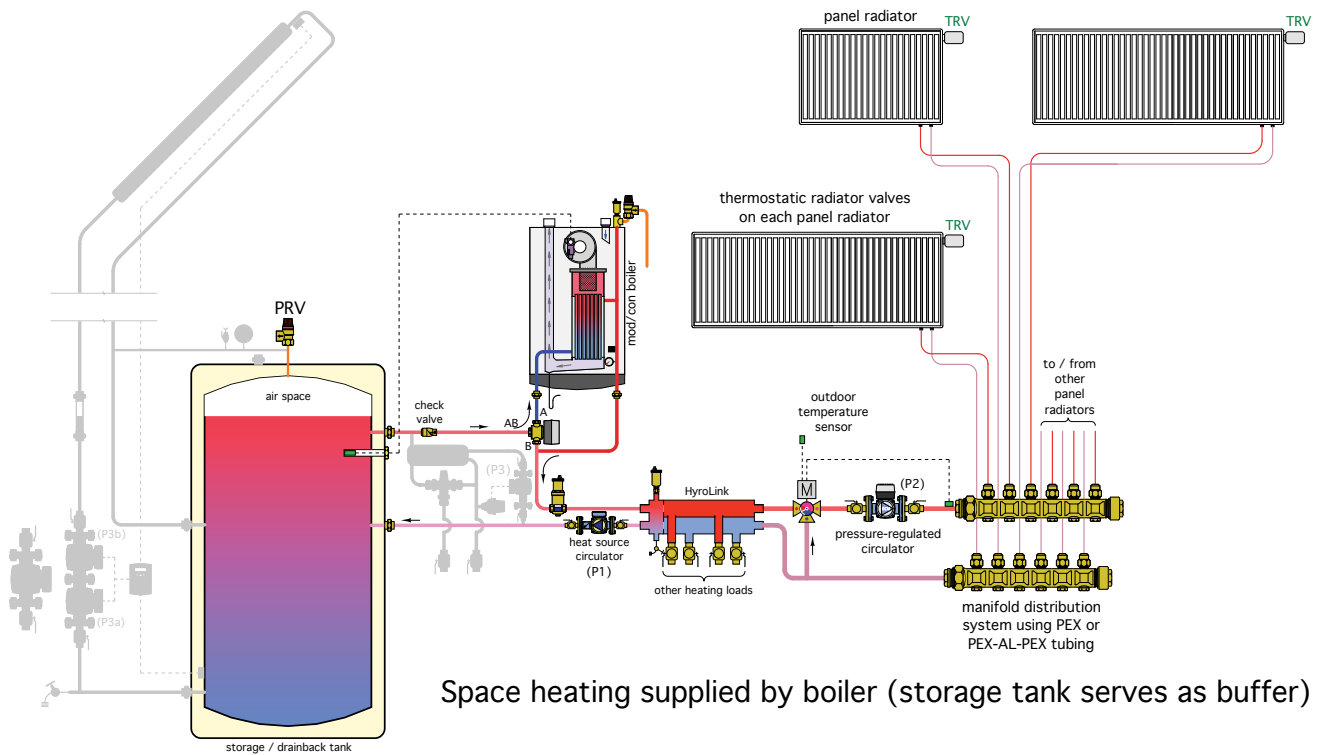
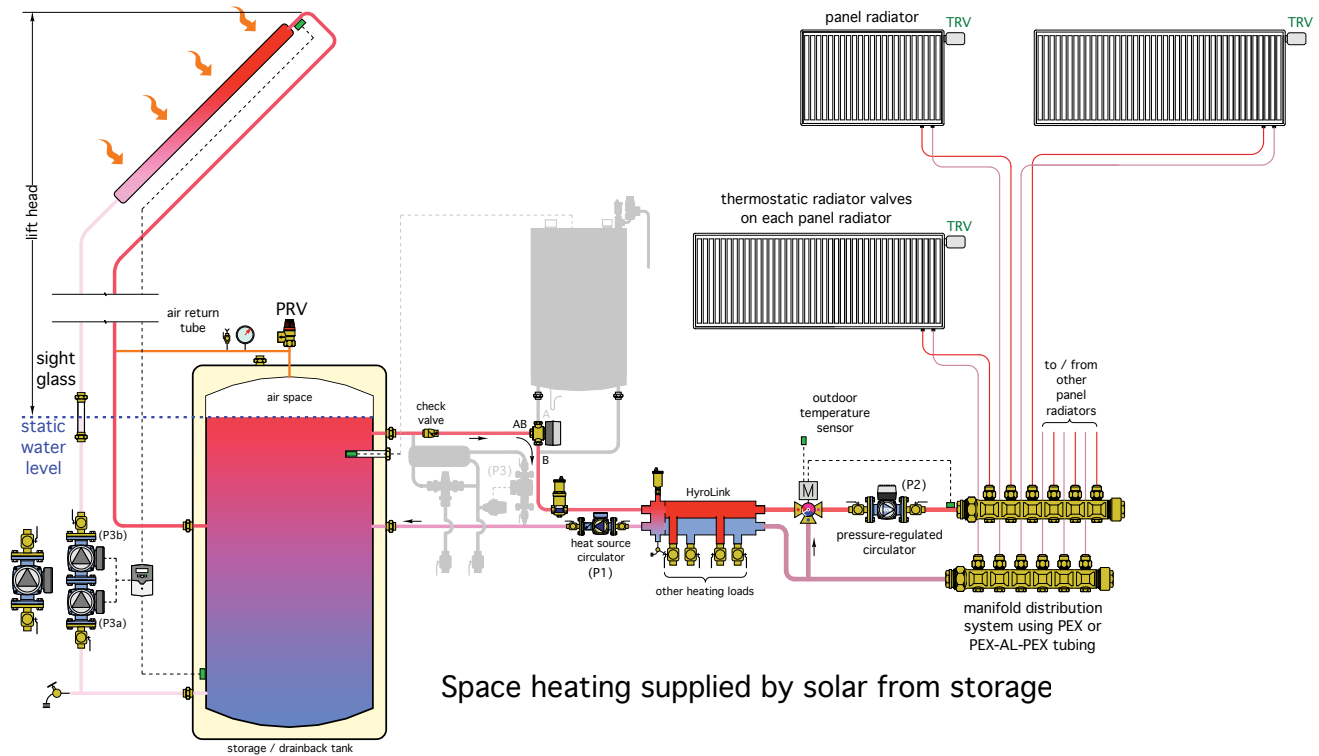

Figure 5-15



water from solar storage tank. Inactive components in the lower schematic are shown in gray.

The upper schematic in 5-15 shows the system supplying space heating from the solar storage tank. The lower schematic shows the system supplying space heating from using the boiler as the heat source and the storage tank as a buffer. Inactive components are shown in gray.

DRAINBACK COMBISYSTEM #4:

Some solar combisystems may include auxiliary heat sources that also require a storage tank. One example is a system using a wood-fired boiler. In these cases, it's often possible to combine the storage requirements into a single tank, as shown in figure 5-16.

This system is built around an unpressurized storage tank. Such tanks typically have an insulated structural shell supporting a flexible waterproof liner. They are vented to the atmosphere and thus not capable of operating under pressure. The air space above the water is sufficient to accommodate thermal expansion of the water. All piping

connections are usually made above the water level to minimize any potential leakage with age. An example of a large (550-gallon) unpressurized storage tank (partially assembled) is shown in figure 5-17.



Figure 5-17

Image courtesy of American Solartechics

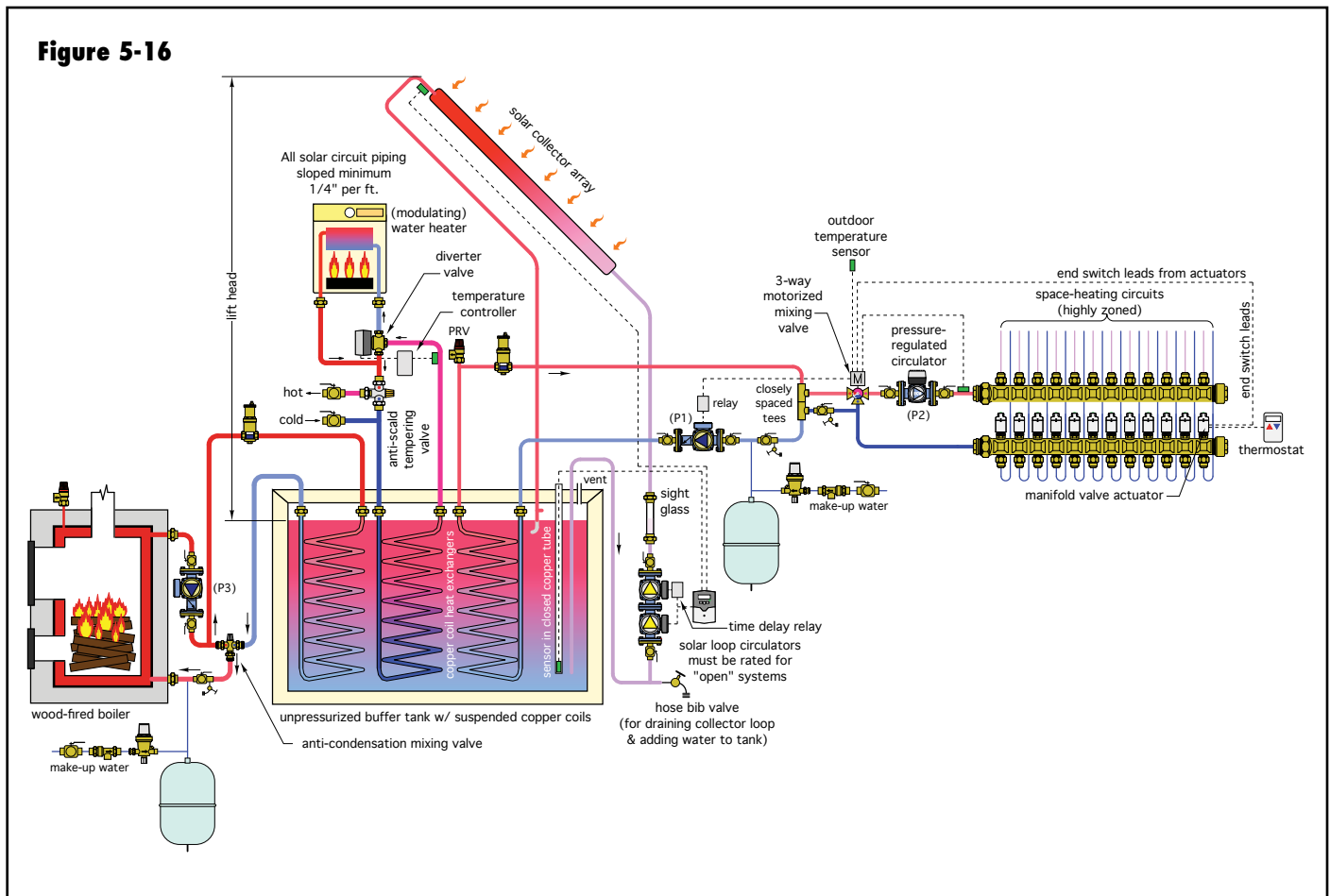

Figure 5-16

All hydronic subsystems connected to this tank are pressurized. They include the boiler circuit, domestic water preheating subsystem and the space heating distribution system. These subsystems absorb or dissipate heat to the water in the tank through large, coiled, copper heat exchangers, such as the one shown in figure 5-18.



Image courtesy of American Solartechinics

This heat exchanger consists of four parallel “windings” of copper tube manifolded together at each end. This configuration produces far less pressure drop than would a single tube coil of the same total length.

The wood-fired boiler heats the tank through a copper coil heat exchanger suspended from the top or side of the tank. This coil and remaining boiler piping constitute a closed hydronic circuit, and therefore require a pressure relief valve and expansion tank. Depending on local codes, the boiler circuit may also require safety devices such as a low-water cut off or manual reset high limit. A 3-way thermostatic mixing valve is used to boost boiler inlet temperature to prevent flue gas condensation within the boiler. This is essential for minimizing creosote formation within the boiler and its venting system.

Domestic water is preheated through another suspended copper coil in the tank. A controller measures the temperature of the water leaving this coil. If it’s hot enough to supply the fixtures, the diverter valve directs it to the anti-scald tempering valve. As in other combisystems, this valve prevents excessively hot water from flowing directly to the fixtures. If the water needs further heating, the diverter valve directs it through the modulating instantaneous water heater. After this, it again passes through the anti-scald mixing valve before going to the fixtures.

Energy for space heating is also extracted from the tank through a third suspended coil. This coil and the remaining space heating piping constitute another closed-loop pressurized subsystem, and thus require a pressure relief valve and expansion tank.

Heat from the collector array is added to the tank through the drainback subsystem. The tank water passes directly through the collector circuit. No heat exchangers are required. The absence of a heat exchanger improves the efficiency of the collectors.

Because this is an open-loop drainback system, the circulators must be bronze, stainless steel or a high-temperature polymer to avoid corrosion. A “dual-pumped” circulator is shown with a time delay relay used to turn off the upper circulator when the siphon is established in the collector return piping.

An elbow located just below the operating water level deflects flow returning from the collectors so it enters the tank horizontally rather than vertically. This helps preserve temperature stratification within the tank. A tee is installed a few inches above the water level to allow air to reenter the return piping fro drainback.

The water level in the tank is indicated by a sight glass installed at a suitable height. Water can be added to the tank through the hose bib valve at the bottom of the collector loop.

An “inverted-U” piping configuration is used to supply the collector circulators. This eliminates the need for piping to penetrate the tank below the water level. This piping should be kept as short and low to the tank top as possible. The collector loop circulators should be mounted as low as possible to maintain some slight positive pressure at their inlet. The inverted U is primed by closing an isolation valve on the solar loop circulators and adding water to the tank at a high flow rate through the hose bib valve. Once filled, the inverted U should remain full of water.

The combination of a solar collector array and wood-fired boiler is synergistic. The boiler will likely be used more during cold and cloudy winter weather. The solar array will produce greater outputs in spring and fall, and may even eliminate the need to operate the wood-fired boiler for domestic water heating during warm weather.

6. PERFORMANCE ESTIMATION:

The performance of any solar energy system obviously depends on weather. As such, it cannot be precisely predicted from one day to the next. In the case of a solar combisystem, performance also depends on both the space heating and domestic hot water loads of the building it serves. Both loads are highly variable depending on personal preferences, energy saving efforts and habits of the building occupants. Compounding this situation are issues such as collector shading at specific times or the possibility of snow on the collectors — even when the sun is out.

Because of the highly variable nature of the source as well as the demand for energy, the performance of solar thermal systems is often estimated through computer simulation. In some cases, these simulations take place on an hour-by-hour basis, or possibly even on a 15-minute basis. Because there are 8760 hours in a year, these calculations are laborious and only capable of being done using a computer.

EXPECTATIONS:

Many people with little more than a philosophical interest in solar heating tend to overestimate the performance of solar energy systems. Upon seeing a typical three- to eight-collector array on a roof, a common question to the building's owner might be: "Can those heat your entire house?" Implicit in this question is optimism that solar collectors might eliminate the need for heat from conventional fuels, such as oil, gas or electricity. Although a lofty goal, this is almost never the case.

Constructing a very large solar thermal system that could approach the ideal of 100% solar heating would be very expensive, and unable to pay for itself in savings over the useful life of the system. Such a system would also generate much more heat than could be used during warmer weather. In short, such a system would be far from economically justifiable. Without economic justification, such systems would have very limited acceptance and contribute very little to widespread use of renewable energy.

The most economical solar combisystems always use a combination of solar and auxiliary energy.

Increasing the size of the solar portion of a combisystem (e.g., more collector area and a larger storage tank) demonstrates the law of diminishing returns. Each time the collector area is increased by a fixed amount, say by adding 100 square feet of collector area to the array, the

resulting savings will be less than that associated with adding the previous 100 square feet. The total savings goes up, but at a constantly diminishing rate.

From an economic standpoint, the goal is to find the best combination of solar-derived and auxiliary heat that produces the lowest life-cycle cost for a given project. This requires knowledge of or accurate estimates for many factors, such as the cost of various-size systems, the thermal performance of the same, the cost of auxiliary heating and its likely rate of inflation several years into the future, the expected cost of system maintenance and insurance, and how the system's economics are influenced by current incentives, such as tax credits and subsidized loans. Having detailed and reliable information on all these considerations during the design process is virtually impossible. The best that can be done is to make estimates, then use a software tool to gauge the sensitivity of the design to variations in these estimates.

f-CHART ANALYSIS:

One established method of predicting the monthly and annual performance of solar combisystems was developed at the University of Wisconsin, Madison during the mid-1970s. It is called f-chart. The letter f stands for fraction—specifically, the fraction of the combined space heating and domestic hot water load that is supplied by solar energy.

f-chart was originally developed as a simplified method for predicting the performance of solar thermal systems for residential-scale applications at a time when the computational performance needed for hour-by-hour simulations was only available on mainframe computers, and thus unavailable to most individuals. f-chart is based on empirical correlations of the results of thousands of hour-by-hour simulations done with a specialized solar simulation program called TRNSYS. In its initial form, the f-chart methodology could be completed using a scientific calculator. Although this is still possible, the methodology has been translated to software and is now available from at least two sources.

Like other solar design tools, f-chart requires several variables to describe the system being modeled. These include:

- Location of installation (weather database)
- Collector area
- Collector efficiency intercept ($FR_{t,a}$)
- Collector efficiency slope (F_{R,U_L})
- Collector slope
- Collector azimuth

- Collector flow rate
- Storage tank volume
- Effectiveness of collector/storage heat exchanger
- Specific heat of collector circuit fluid
- Space heating load
- Domestic hot water load

Once a specific system is defined by these inputs, f-chart calculates several outputs on a monthly and annual basis. These include:

- Total solar radiation incident on the collector area
- Space heating load of the building
- Domestic water heating load of the building
- Auxiliary energy needed for space heating and DHW
- Percentage of the monthly (space heating + DHW) load supplied by solar

An output screen listing these outputs for a specific combisystem is shown in figure 6-1. The lowest line is the annual total of the monthly quantities listed above it, except for the solar fraction (f), in which case the lower line gives the annual solar fraction. For the results given in figure 6-1, solar energy supplied 0.235 (e.g., 23.5%) of the annual total space heating plus domestic water heating load.

CASE STUDIES:

The performance of some representative solar combisystems will now be discussed. These combisystems have been designed for two different houses: one with a design heating load of 35,000 Btu/hr and the other with a design heating load of 100,000 Btu/hr.

Each house is assumed to be located in Syracuse, New York (a cold and relatively cloudy winter climate), as well as in Colorado Springs, Colorado (a cold but relatively sunny winter climate).

Each house has been analyzed with two different combisystems: One built around four 4-foot by 8-foot flatplate collectors with 256 gallons of water storage, and the other built around eight of the same collectors and 512 gallons of storage.

Other specific data for each system is as follows:

For the smaller house:

- Design heating load = 35,000 Btu/hr, with outdoor temperature = 0°F and indoor temperature is 70°F
- Domestic water heating load = 60 gallons per day heated from the local cold water temperature to 125°F.

For the larger house:

- Design heating load = 100,000 Btu/hr, with outdoor temperature = 0°F and indoor temperature is 70°F
- Domestic water heating load = 100 gallons per day heated from the local cold water temperature to 125°F.
- Each system uses drainback freeze protection with no collector-to-storage heat exchanger
- Collectors are 4-foot by 8-foot, with a gross area of 32 square feet each
- Collector efficiency intercept is 0.76, and the efficiency slope is 0.865 (Btu/hr/ft²/°F)
- Collector arrays are sloped at local latitude +15°
- Collector arrays face directly south
- Storage volume is 2 gallons per square foot of collector area

Figure 6-1

	Solar [10 ⁶ Btu]	Heat [10 ⁶ Btu]	Dhw [10 ⁶ Btu]	Aux [10 ⁶ Btu]	f []
Jan	3.769	15.63	1.224	15.15	0.101
Feb	4.087	13.64	1.105	12.79	0.133
Mar	5.047	11.55	1.219	10.32	0.192
Apr	5.247	6.93	1.172	5.60	0.309
May	5.559	3.19	1.205	2.03	0.537
Jun	5.552	0.92	1.161	0.23	0.892
Jul	5.897	0.35	1.196	0.00	1.000
Aug	5.732	0.57	1.198	0.02	0.986
Sep	5.189	1.92	1.163	0.97	0.686
Oct	4.583	5.52	1.208	4.57	0.321
Nov	3.013	8.85	1.175	8.77	0.125
Dec	2.940	13.55	1.221	13.62	0.078
Year	56.616	82.62	14.247	74.06	0.235

The performance estimates that follow were all determined using f-chart software.

Figure 6-2 shows the monthly solar fractions for both combisystems in the smaller house located in Syracuse, NY.

Notice that several bars representing the solar fraction in mid-year reach 100%, even for the smaller combisystem. This happens because the collector array can generate more heat than the load requires at this time of year. During the colder months, the larger system has approximately double the solar fraction of the small system. However, on an annual basis, the four-collector system meets 23.5% of the total load of the smaller house, whereas the 8-collector

Figure 6-2

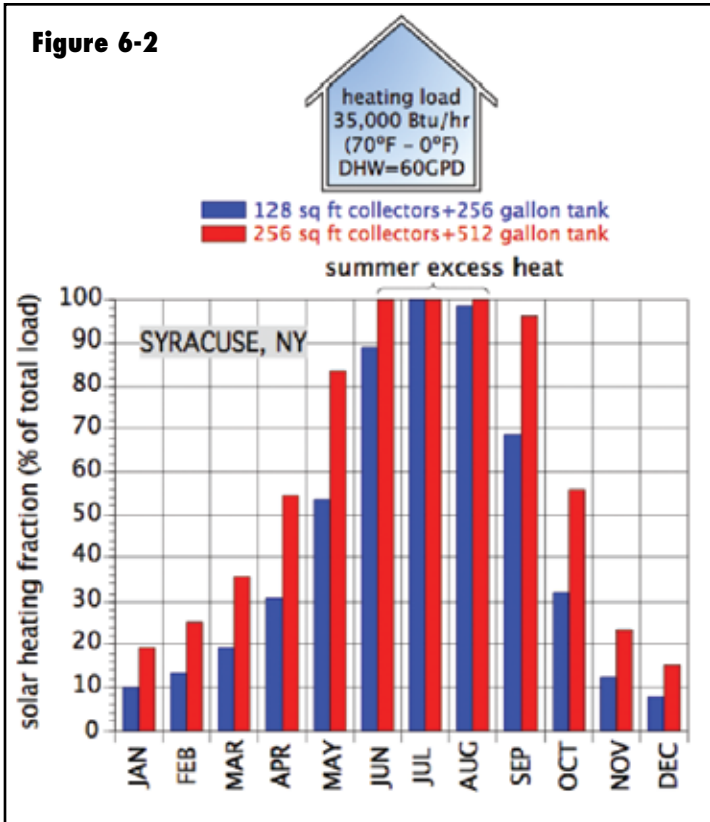

system meets 37.4% of the total load. Thus, the smaller system produced about 63% of the savings associated with the larger system. Although double in size, the larger system did not double the energy savings. This is largely because of the lack of load in warmer weather, where the higher potential output of the larger system is of essentially no use.

It follows that the economic return on investment of the smaller system, per square foot of collector area, is greater than that of the larger system. The choice of which system to install should consider this, as well as the goals of the owners and the available space required for each system. If the choice is largely driven by economic considerations, the smaller system is the better choice. However, if the owner's desire is to cover a greater percentage of the load, and both the space and funds are available, the larger system may be selected. Ultimately, most combisystem sizes are selected based on the owner's weighted preferences for performance, economic return and philosophical commitment to renewable energy use.

Figure 6-3 shows the performance prediction for the larger house in Syracuse, NY, with the same two combisystems.

Figure 6-3

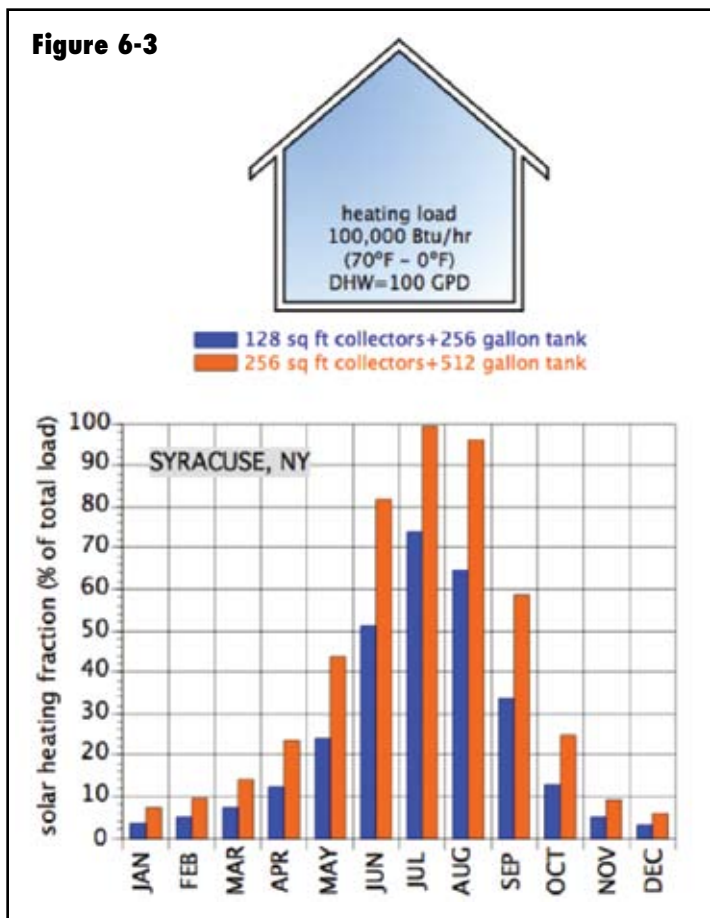

Notice that only one bar — that associated with the larger (8 collector) system — reaches the 100% mark in July. The larger load — especially that associated with 100 gallons per day of domestic hot water — makes better use of the collected energy. The eight-collector system still approximately doubles the monthly fraction of the four-collector system from November through March. The annual solar fraction of the smaller system is 10.1% versus 18% for the larger system. Again, having twice the collector and storage size does not double the annual solar yield. However, the difference is more significant in this application relative to the small-house application because there is less wasted solar energy during warmer weather (e.g., the larger domestic water heating load makes better use of the available solar energy).

Moving both of these systems to Colorado Springs, Colorado, increases both the monthly and annual solar fractions, as shown in figure 6-4.

Given the more favorable solar climate, the system on the smaller house experiences even more excess energy in warmer weather, especially if the larger collector array is used. The annual solar fraction for the four-collector system is now 34.8% versus 54.6% for the eight-collector system. Using twice the collector area and storage yields about 57% more collected energy on an

Figure 6-4

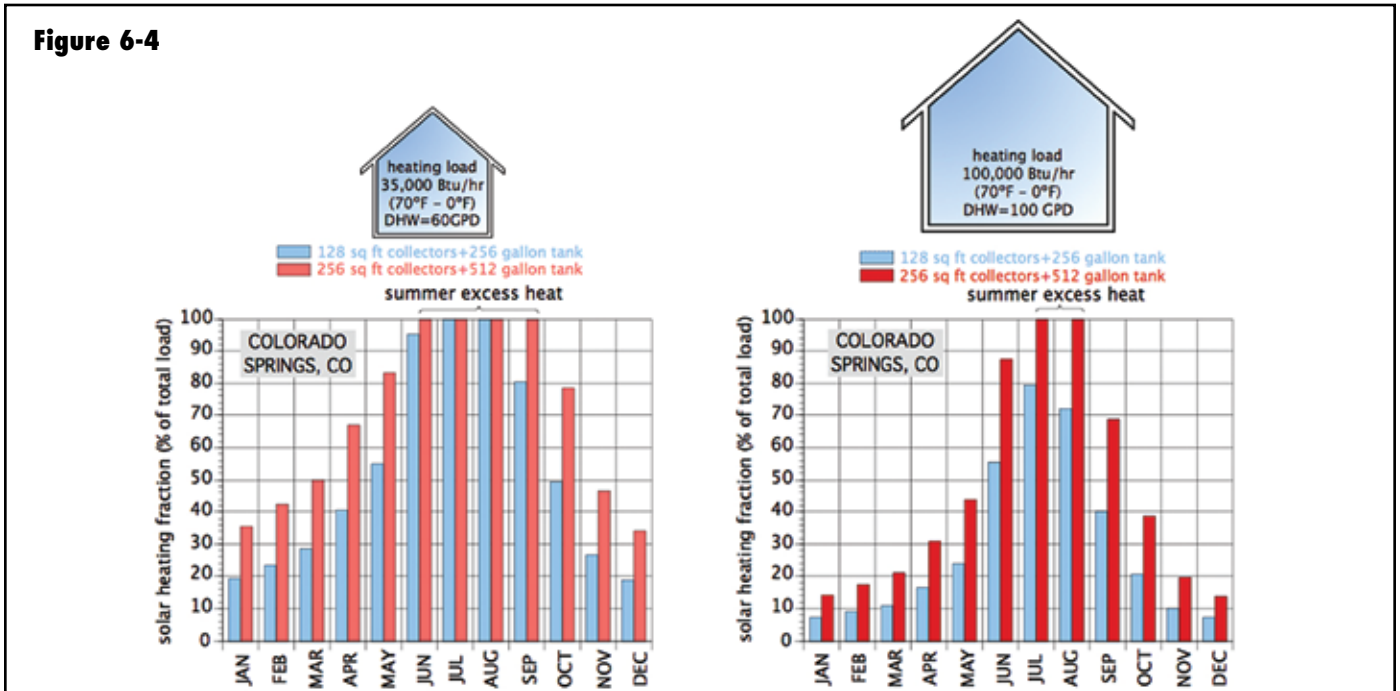

annual basis. The diminishing return on the larger system is again attributable to lack of load in warmer weather.

The larger house, with its larger load reduces this excess, but doesn't eliminate it for the eight-collector system in either July or August. The annual solar fraction for the four-collector system on the larger house is now 15.1% versus 26.9% for the eight-collector system.

The most important point to be taken from these comparisons is that large solar combisystems in typical residential applications do not offer the same economic advantages of smaller combisystems. This is due to loads being far less than the potential amount of heat collection from a large collector array.

In some installations, the greater summertime energy delivery of a solar combisystem could be used to heat to a swimming pool. Heated fluid from the collector array would be sent through a stainless steel heat exchanger connected to the pool's filter system. Assuming this energy displaced other conventional energy for pool heating, the economic viability of the system would definitely improve.

Another way to add load to the system in summer is to dissipate heat into the loop field used for a geothermal heat pump system. This could allow some quantity of solar-derived heat to be stored in the earth—heat that could later be recovered and used during the heating season. However, the feasibility of this concept precludes situations where the geothermal loop field is also being used to dissipate heat from a building cooling system.

It also requires assurance that underground aquifers will not be carrying away that heat prior to its recovery.

The potential for excess heat production in summer also favors the use of drainback freeze protection versus antifreeze in combisystem applications. When no more energy can be delivered to storage, the drainback system drains and the collector array "dry stagnates." In an antifreeze-based system, a heat-dumping subsystem must be operational to prevent rapid thermal deterioration of the antifreeze solution.

COLLECTOR ORIENTATION IN COMBISYSTEMS:

The theoretical optimum collector orientation for a combisystem is true (polar) south. However, site conditions that create shading may justify different orientations. Variations up to 30 degrees East or West of true South typically result in less than 10% loss of annual solar energy collection.

An accepted rule of thumb for collector slope in combisystem applications is latitude plus 15 degrees. The steeper slope, relative to collectors used solely for domestic water heating, favors winter sun angles, and improves performance when heating loads are greatest. Steeper collector slopes also reduces solar radiation on collectors during warmer weather when loads are small, and thus reduce the potential for overheating. Collectors mounted to a vertical, south-facing, unshaded wall (slope angle = 90 degrees) yield approximately 20% less energy gain than collectors mounted at an optimal slope.

STORAGE TANK SIZE IN COMBISYSTEMS:

The size of the combisystems's storage tank affects its annual performance. A rule of thumb is to size storage tanks in combisystems within the range of 1.25 to 2.5 gallons per square foot of collector area. Tanks larger than the upper end of this range usually show little return on the extra investment. Research has even shown that tanks larger than about 3.7 gallons per square foot of collector can decrease annual system performance due to increased heat losses.

Figure 6-5

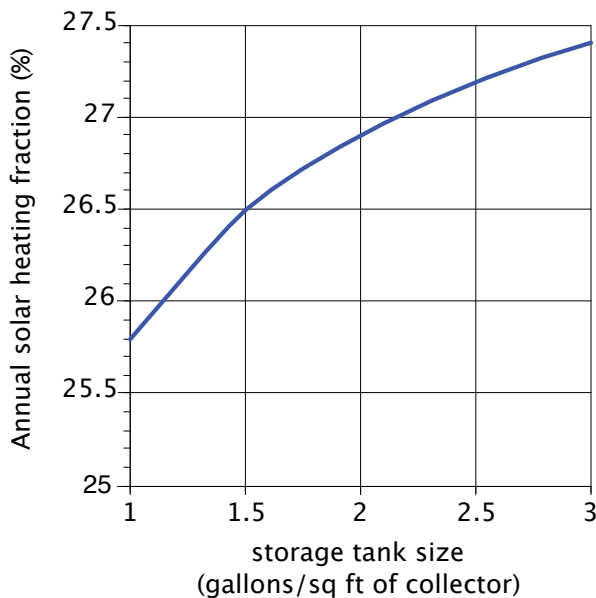

Figure 6-5 shows the affect of storage tank size on the annual solar heating fraction for the 8-collector system on the larger house in Colorado Springs, as discussed earlier in this section. There is an increase in annual solar heating fraction as tank volume increases, but the rate of increase goes down as the size of the tank increases.

SUMMARY:

Solar thermal combisystems are a natural extension of solar domestic water heating. Their objective is to provide a high percentage of the building's domestic hot water and some percentage of its space heating energy.

There are countless variations in how solar combisystems can be designed. A system that's "perfect" for one situation may not be suitable for the next. However, all combisystems should address the following considerations.

- For best performance, solar subsystems should be interfaced with space heating delivery systems that operate at low water temperatures. Do not simply assume that

a solar subsystem can interface directly to any existing space heat distribution system. A suggested maximum operating temperature for a space heating distribution system that will interface to solar collectors is 120°F.

- All combisystems must include mixing assemblies that prevent potentially high-temperature water generated by the solar subsystem from reaching low-temperature heat emitters. This mixing device can be operated based on outdoor reset control logic to allow the lowest possible water temperatures to satisfy the load.

- All systems should include a simple and automatic means of switching the distribution system from using the storage tank as the heat source to some form of auxiliary heating when necessary. Building occupants should not experience any loss of comfort as the system transitions between these heat sources. An outdoor reset controller that calculates the lowest possible temperature at which the solar storage tank can supply the load is ideal for selecting which heat source supplies the distribution system.

- All solar combisystems benefit from the same state-of-the-art hydronics technology used in non-solar hydronic systems. These technologies include pressure-regulated circulators in combination with valve-based zoning, hydraulic separation, manifold-based distribution systems and high-performance air separation.

- All combisystems should provide year-round preheating of domestic water, and thus utilize solar-supplied heat at its lowest possible temperature.

- For good performance, the effectiveness of the collector-to-storage heat exchangers in antifreeze-based systems should be at least 0.55 (see appendix B for information on calculating heat exchanger effectiveness).

- Systems should be designed with the assistance of software. The latter can be used to estimate the combined effects of many variables that vary from one system to the next.

- All piping components should be well insulated to minimize extraneous heat loss and optimize the delivery of heat precisely where and when it's needed.

- Optimum collector orientation in combisystem applications is generally due south, with a slope angle of latitude plus 15 degrees.

- Storage tanks in combisystem applications should be sized between 1.25 and 2.5 gallons per square foot of collector area. Tanks larger than this add very little to annual system performance.

APPENDIX A: Piping Symbol Legend

GENERIC COMPONENTS

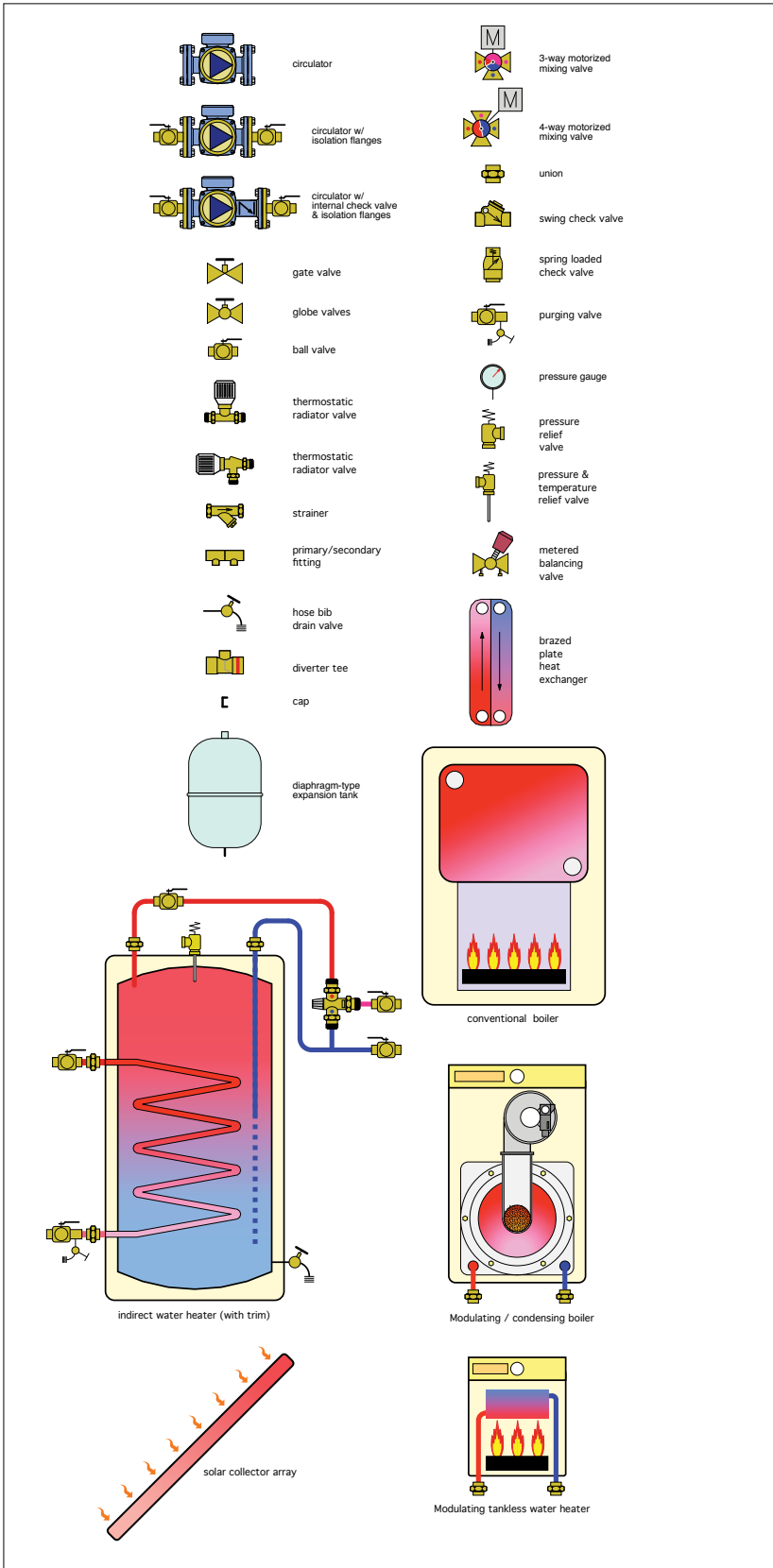

CALEFFI COMPONENTS

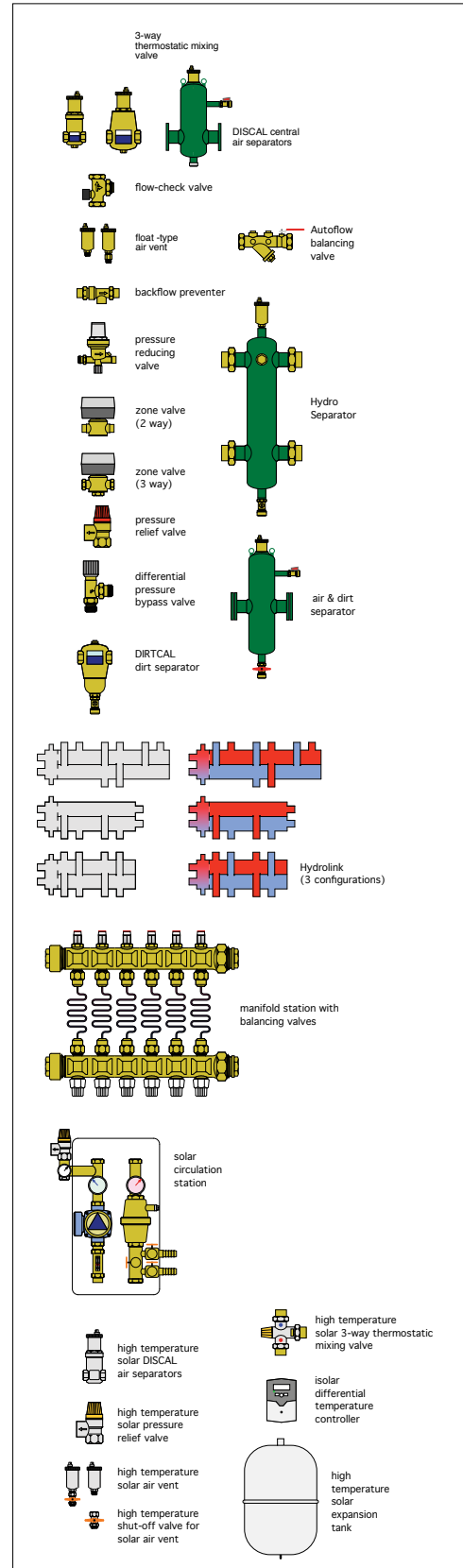

APPENDIX B: Heat Exchanger Performance:

Heat exchanger performance is often expressed as “effectiveness,” which is defined as follows:

$$e = \text{effectiveness} = e = \frac{\text{actual heat transfer rate}}{\text{maximum possible heat transfer rate}}$$

The actual rate of heat transfer can be determined based on the flow rate, specific heat and temperature change of either fluid, as shown in figure B-1.

Figure B1

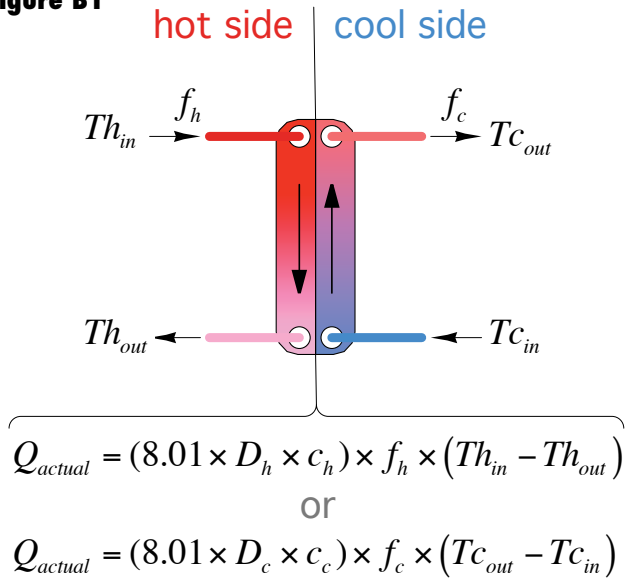

Where:

Q_{actual} = actual rate of heat transfer across heat exchanger (Btu/hr)

8.01 = unit conversion factor

D_h = density of fluid through **hot** side of heat exchanger (lb/ft³)

D_c = density of fluid through **cool** side of heat exchanger (lb/ft³)

c_h = specific heat of fluid through **hot** side of heat exchanger (Btu/lb/°F)

c_c = specific heat of fluid through **cool** side of heat exchanger (Btu/lb/°F)

f_h = flow rate of fluid through **hot** side of heat exchanger (gpm)

f_c = flow rate of fluid through **cool** side of heat exchanger (gpm)

T = temperatures at locations shown in figure (°F)

The maximum possible rate of heat transfer through the heat exchanger can be calculated as follows:

$$Q_{max} = [8.01 \times D \times c \times f]_{min} \times (Th_{in} - Tc_{in})$$

Where:

$(8.01 \times D \times c \times f)_{min}$ = the smaller of the two fluid capacitance rates. Found by calculating the product $(8.01 \times D \times c \times f)$ for both the hot and cool side of the heat exchanger and then selecting the smaller of the two.

Th_{in} = inlet temperature of the **hot** fluid (°F)

Tc_{in} = inlet temperature of the **cool** fluid (°F)

As the size of the heat exchanger increases relative to the required rate of heat transfer, its effectiveness approaches the theoretical limiting value of 1.0.

Example: A heat exchanger in a solar combisystem operates at the conditions shown in figure B-2. The fluid in the collector loop is a 40% solution of propylene glycol. The fluid on the cool side of the heat exchanger is water. Determine the rate of heat transfer across the heat exchanger and its effectiveness under these operating conditions.

Figure B2

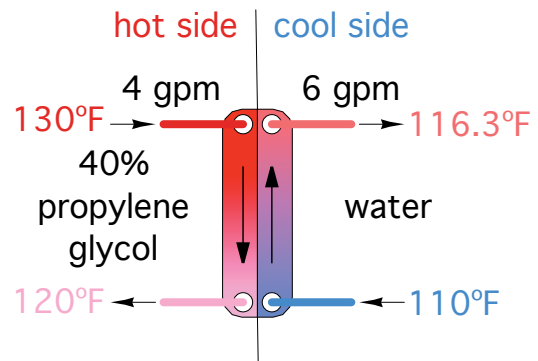

Start by finding the fluid properties of both the 40% propylene glycol solution and water at the average temperature of each fluid as it passes through the heat exchanger.

For the 40% propylene glycol solution:

$D = 64.0$ lb/ft³

$c = 0.91$ Btu/lb/°F

For water:

$D = 61.8$ lb/ft³

$c = 1.00$ Btu/lb/°F

Next, calculate the actual rate of heat transfer across the heat exchanger. This can be done using data from either flow stream. In this case, the data from the flow stream through the hot side of the heat exchanger (using the 40% propylene glycol solution) is used:

$$Q_{actual} = (8.01 \times D_h \times c_h) \times f_h \times (Th_{in} - Th_{out}) = (8.01 \times 64.0 \times 0.91) \times 4 \times (130 - 120) = 18,660 \text{ Btu/hr}$$

Next determine which side of the heat exchanger has the minimum fluid capacitance rate (e.g., calculate the product $(8.01 \times D \times c \times f)$ for each flow stream and determine which is smaller).

For the hot side of the heat exchanger:

$$(8.01 \times D \times c \times f)_{40\%PG} = (8.01 \times 64.0 \times 0.91 \times 4) = 1866 \frac{Btu}{hr \cdot ^\circ F}$$

For the cool side of the heat exchanger:

$$(8.01 \times D \times c \times f)_{water} = (8.01 \times 61.8 \times 1.00 \times 6) = 2970 \frac{Btu}{hr \cdot ^\circ F}$$

The fluid capacitance rate on the hot side of the heat exchanger is the smallest.

Determine the maximum possible heat transfer across the heat exchanger. This corresponds to a thermodynamic limit in which the outlet temperature of the fluid with the lower fluid capacitance rate approaches the inlet temperature of the other fluid stream. It is determined by multiplying the minimum fluid capacitance rate by the difference in temperature between the entering hot fluid and the entering cool fluid. This difference is often called the "approach" temperature difference.

$$Q_{max} = [8.01 \times D \times c \times f]_{min} \times (T_{h,in} - T_{c,in}) = [8.01 \times 64.0 \times 0.91 \times 4] \times (130 - 110) = 37,320 Btu / hr$$

Finally, determine the effectiveness of the heat exchanger under these conditions.

$$e = \frac{Q_{actual}}{Q_{max}} = \frac{18,660}{37,320} = 0.50$$

COLLECTOR HEAT EXCHANGER PERFORMANCE PENALTY:

The decrease in solar energy collected as a result of having a heat exchanger between the collector loop fluid and the storage tank can be estimated using the following formula.

$$CF = \frac{1}{1 + \left[\left(\frac{(F_R U_L) \times A_{ca}}{8.01 \times D \times c \times f_{ca}} \right) \times \left(\frac{1}{\epsilon} - 1 \right) \right]}$$

Where:

- CF = correction factor (derating multiplier)
- $F_R U_L$ = slope of collector efficiency line (Btu/hr/ft²/°F)
- A_{CA} = area of collector array (ft²)
- D = density of collector loop fluid (lb/ft³)
- c = specific heat of collector loop fluid (Btu/lb/°F)
- f_{ca} = fluid flow rate through collector array (gpm)
- e = effectiveness of collector/storage heat exchanger.

The correction factor is a derating multiplier. For example, if the correction factor were 0.95, the collector array and

heat exchanger used as a system, would gather 95% of the amount of solar energy compared to the same collector array without the heat exchanger. This could also be viewed as a 5% performance penalty due to the presence of the heat exchanger.

Figure B-3 shows how the correction factor varies as a function of the heat exchanger's effectiveness. This graph is for a small combisystem using four 4-foot by 8-foot flat plate collectors, a 50% solution of propylene glycol as the collector fluid and a flow rate of 1 gallon per minute per collector. The collector's efficiency line has a slope ($F_R U_L$) of 0.865 Btu/hr/ft²/°F.

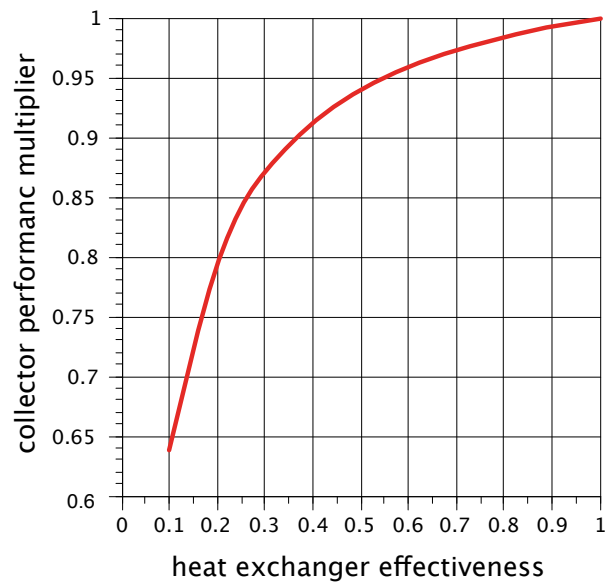

The graph shows that heat exchangers with low effectiveness numbers (less than 0.55) create significant performance penalties (over 5% reduction in energy gain). It is suggested that all collector-to-storage heat exchangers used in solar combisystems have effectiveness ratings of 0.55 or higher, and thus impose losses of not more than 5% on solar energy collection.

APPENDIX C: TANK AND PIPING VOLUME FORMULAS:

This section provides data and formulas for calculating the volumes of tanks and piping. This is useful for tasks such as determining the drop in water level of a specific size storage tank when a given volume of water is extracted (such as when a drainback system begins the collection cycle).

Formula C-1 can be used to calculate the volume of a cylindrical storage tank of known diameter and height:

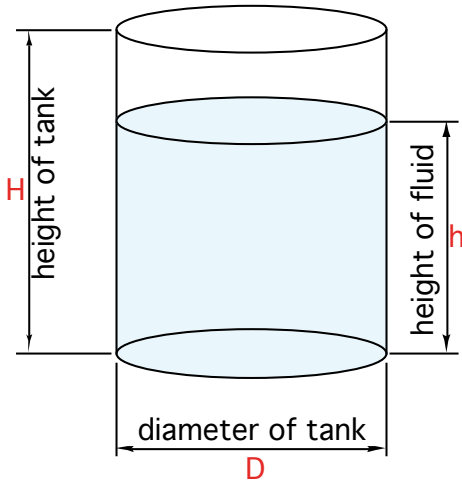

Formula C-1:

$$V_{\text{tank}} = \frac{\pi(D^2)H}{924}$$

Where:

- V_{tank} = volume of tank (US gallons)
- D = diameter of tank (inches)
- H = height of tank (inches)

Formula C-2 can be used to calculate the volume of liquid of known height h with a cylindrical storage tank of known diameter and height:

Formula C-2:

$$V_{\text{fluid}} = \frac{\pi(D^2)h}{924}$$

Where:

- V_{fluid} = volume of fluid in tank (U.S. gallons)
- D = diameter of tank (inches)
- h = height fluid in tank (inches)

PIPE VOLUME DATA:

The following table can be used to calculate the volume of piping in solar as well as other types of hydronic systems.

Tube type / size	Gallons /foot
3/8" type M copper:	0.008272
1/2" type M copper:	0.0132
3/4" type M copper:	0.0269
1" type M copper:	0.0454
1.25" type M copper:	0.068
1.5" type M copper:	0.095
2" type M copper:	0.165
2.5" type M copper:	0.2543
3" type M copper:	0.3630
3/8" PEX	0.005294
1/2" PEX	0.009609
5/8" PEX	0.01393
3/4" PEX	0.01894
1" PEX	0.03128
1.25" PEX	0.04668
1.5" PEX	0.06516
2" PEX	0.1116
3/8" PEX-AL-PEX	0.00489
1/2" PEX-AL-PEX	0.01038
5/8" PEX-AL-PEX	0.01658
3/4" PEX-AL-PEX	0.02654
1" PEX-AL-PEX	0.04351

APPENDIX D: UNIT CONVERSION FACTORS:

Temperature:

$$^{\circ}F = ^{\circ}C \times (1.8) + 32$$

Temperature difference (ΔT):

$$1^{\circ}F = 0.555555^{\circ}C$$

Heat:

$$1Btu = 0.000293kwhr = 1054.8joule = 1.0548kilojoule$$

Power:

$$1\frac{Btu}{hr} = 0.2929974w = 0.0002929974kw$$

Pressure:

$$1psi = 0.068946bar = 6894.76Pa = 6.89476KPa$$

Volume:

$$1gallon = 3.78533liter = 0.0037854meter^3$$

Flow rate:

$$1gpm = 0.227126\frac{meter^3}{hour} = 0.0630888\frac{liter}{second}$$

Solar radiation intensity (e.g., "insolation"):

$$1\frac{Btu}{hr \cdot ft^2} = 3.15378\frac{watt}{meter^2}$$

Inlet fluid parameter:

$$1\frac{^{\circ}F \cdot hr \cdot ft^2}{Btu} = 0.176\frac{^{\circ}C \cdot m^2}{w}$$

Flat Plate Solar Thermal Collectors

series NAS100



Function

Solar thermal collectors are used to capture energy from the sun and efficiently transfer solar energy to heat the solar fluid in the primary circuits of solar heating systems. This heated solar fluid is circulated through a heat exchanger, thus heating domestic water, which is stored in suitable tank. This heated water is then delivered to a conventional water heater for final heating, if required, or direct use.



Product range

Code NAS10406	Solar Flat Plate Solar Collector, 4' x 6.5' frame, SRCC rating Category C	7.5 kWh (25,000 Btu)
Code NAS10408	Solar Flat Plate Solar Collector, 4' x 8' frame, SRCC rating Category C	9.2 kWh (32,000 Btu)
Code NAS10410	Solar Flat Plate Solar Collector, 4' x 10' frame, SRCC rating Category C	11.7 kWh (40,000 Btu)

Technical specifications

- Materials:
- absorber plate: 1/2" tube to fin copper
 - absorber coating: selective crystal coating
 - absorptivity / emissivity 0.96 / 0.08
 - header manifold: 1" copper
 - glazing: low iron tempered glass
 - glazing seal: extruded "U" channel EPDM
 - insulation: R-10 poly-isocyanurate foam board
 - frame & battens: type 6063-T6 extruded aluminum
 - backing sheet: type 3105-H14 embossed aluminum

Medium: water, glycol solutions
 Max. percentage of glycol: 60%

Working temperature range: -40 to 350°F (-40 to 177°C)

Max. pressure: 150 psi (10 bar)
 Working pressure: 90 psi (6 bar)

Typical transfer flow rate: 0.5–1.8 gpm (1.8 – 7 lpm)

Connections: 1" union thread (4' x 6.6')
 1-1/4" union thread (4' x 8' & 4' x 10')

Wind load rating: 181mph / 291kph

Dimensions

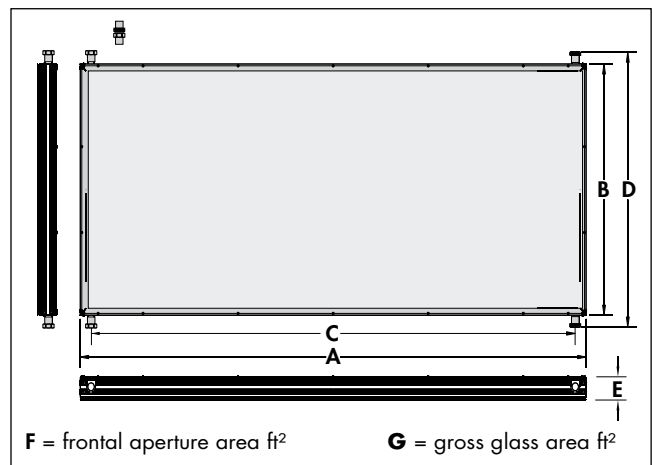

Code	A	B	C	D	E	F	G	Wt (lb)	Cap (gal)
10406	77 3/16"	47 3/16"	74 5/8"	50 1/2"	3 1/8"	23.6	25.35	90	0.79
10408	97 3/16"	47 3/16"	94 5/8"	50 1/2"	3 1/8"	29.9	31.91	113	0.88
10410	121 3/16"	47 3/16"	118 5/8"	50 1/2"	3 1/8"	37.4	39.79	160	1.05

Hydraulic characteristics

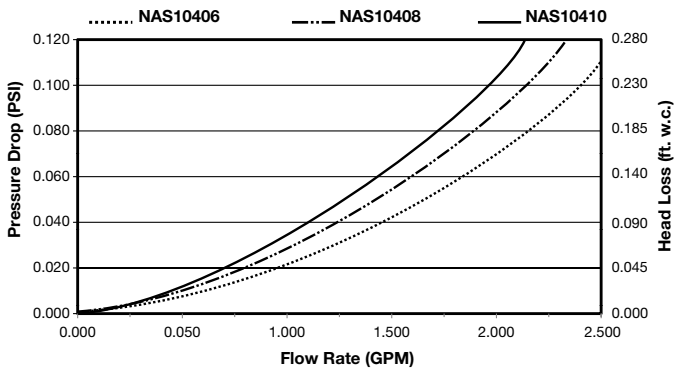

Universal mount system

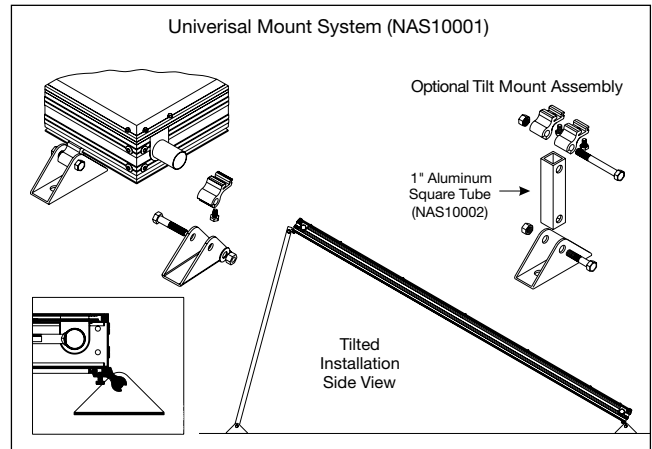

Construction details

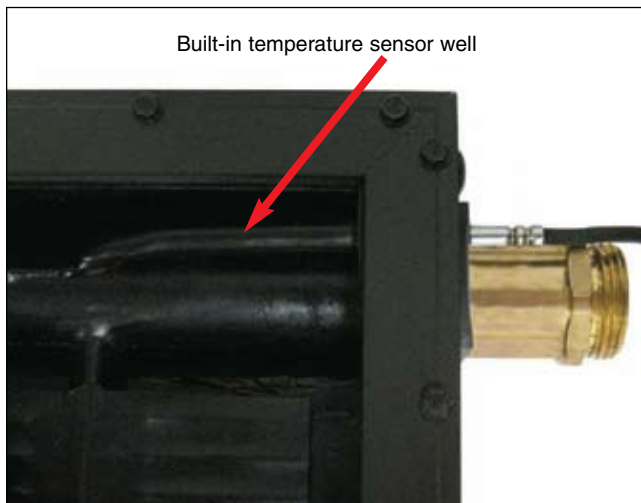

Caleffi's exclusive universal mounting systems allow for virtually any collector orientation and mounting. Collectors can be mounted to any roof, vertical wall, fascia boards, pre-constructed racks or ground mount systems. The frame wall and mount have been certified to withstand 180 mph winds. The frame wall will accept the mounts anywhere around the collector without drilling or tapping so the integrity of the framewall is not violated. The rear struts can be cut to any length allowing proper elevation and orientation.

Item	Code	Description
	NAS10001	Universal foot mounts for solar collectors, flush or tilt mount (4 each with hardware)
	NAS10002	6' extension square brace to tilt collectors

Collector cross section

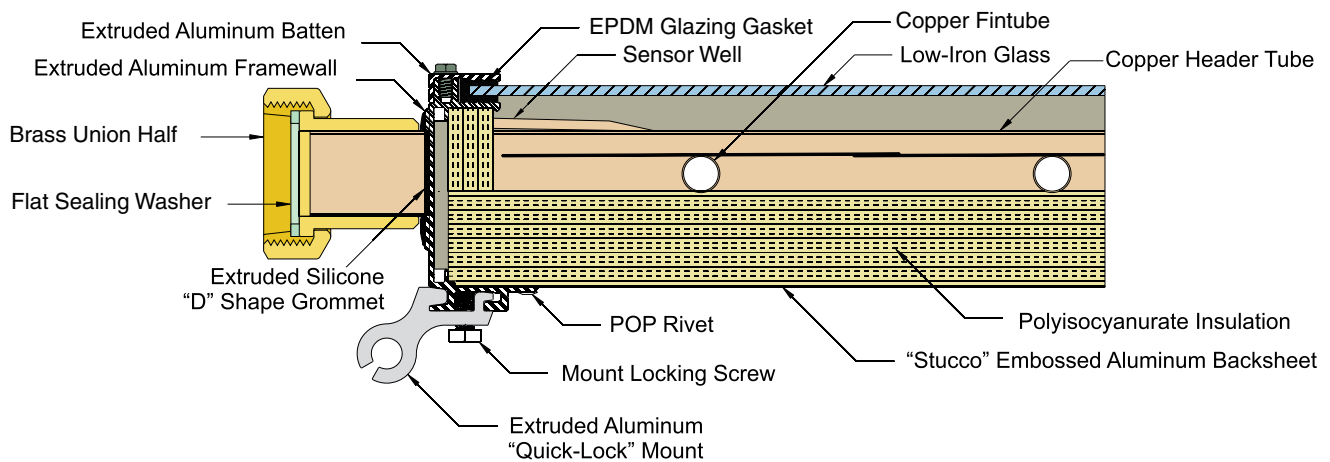

SolarCon solar water heater tank

series NAS200



Meets and exceeds CSA C309 requirements

Function

The solar water heater has either one or two internal coils and a backup electric heating element in the single coil units. A heating medium is passed through the solar panels and internal coil as long as there is an adequate temperature difference between the heating medium and stored water in the tank. The internal coil is located as close to the bottom to facilitate the transfer of heat even at lower solar panel temperatures.

During periods of water flow through the water heater, hot water is drawn from the top of the heater and cold water comes into the bottom of the tank (by a dip tube or bottom inlet). On single coil tanks, if the hot water demand should exceed the solar heat input or there is an insufficient temperature difference between the heating medium and stored water, the heating element thermostat will activate the electrical heating element for backup heat. On double coil tanks, the upper tank is connected to the boiler for backup heat.

Solar heat output from the internal coil will vary depending on outside conditions and the temperature of the stored water.

Product range

NAS20053	Storage tank with lower coil and back up electric element	50 gallon
NAS20083	Storage tank with lower coil and back up electric element	80 gallon
NAS20123	Storage tank with lower coil and back up electric element	119 gallon
NAS20082	Storage tank with lower coil and top coil for boiler back up	80 gallon
NAS20122	Storage tank with lower coil and top coil for boiler back up	119 gallon
NAS20124	Storage tank with lower coil and top coil heat exchanger with back up electric element	119 gallon

Technical specifications

Tank materials:	porcelain coated steel
Tank insulation:	2" non-CFC foam
Tank external cover:	powder-coated steel (20-24 ga.)
Insulation thermal conductivity:	R16
Anode rods:	2 each magnesium
Internal heat exchanger coil (lower):	1-1/2" x 30' (50 gallon)
	1-1/2" x 36' (80, 119 gallon)
Internal heat exchanger coil (top):	1-1/2" x 24' (80, 119 gallon)

Connections:	3/4" NPT (50 gal.), 1" NPT (80, 119 gal.)
Maximum working pressure:	150 psi
Testing pressure:	300 psi
Temperature and pressure relief valve:	210°F/150 psi max
Maximum tank temperature:	180°F
Recommended maximum delivery hot water temperature:	120°F
Power requirements (electric element):	240 VAC
Power consumption (electric element):	4.5 KW
Agency approval:	UL listed

Capacity and performance

Model	Actual Tank Volume (gal)	Coil Volume Solar/Boiler (gal)	Coil Surface Area Solar/Boiler (ft ²)	Coil Friction Loss* Solar/Boiler (ft. of head)	First Hour Rating (gal)	Recovery Rate Solar & Backup [#] (gal/hr)	Standby Loss Rating (°F/hr)
NAS20053	45	2.30/ -	11.78/ -	0.50/ -	91	51	1.1
NAS20083	75	2.76/ -	14.14/ -	0.60/ -	126	56	0.8
NAS20123	110	2.76/ -	14.14/ -	0.60/ -	158	56	1.2
NAS20082	73	2.76/1.84	14.14/9.42	0.60/0.40	226	158	0.8
NAS20122	108	2.76/1.84	14.14/9.42	0.60/0.40	258	158	1.2
NAS20124	108	2.76/1.84	14.14/9.42	0.60/0.40	282	182	1.2

NOTES: * Based on 5 GPM flow rate.

Based on solar input of 140°F @ 2 GPM. Depending on model, backup heat recovery is calculated with either a 4500W heating element or a boiler with output of 180°F at 14 GPM. Potable water temperature rise is 77°F.

Dimensions

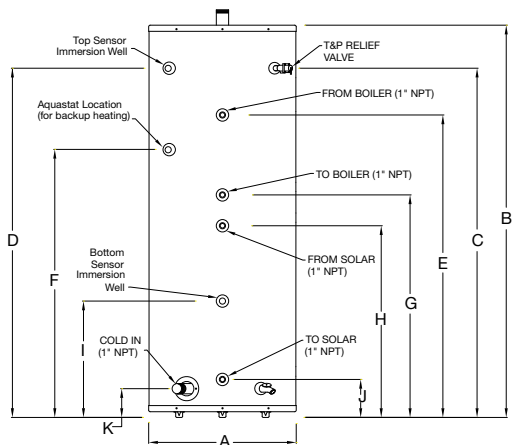
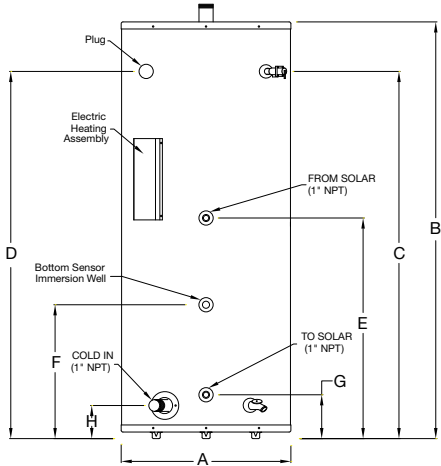
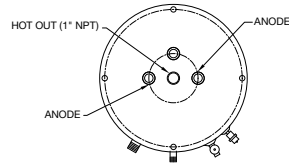
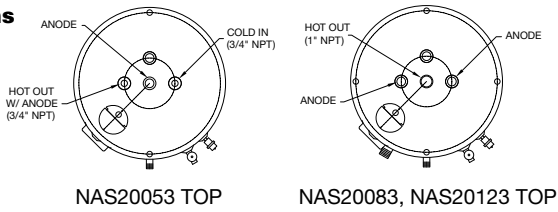
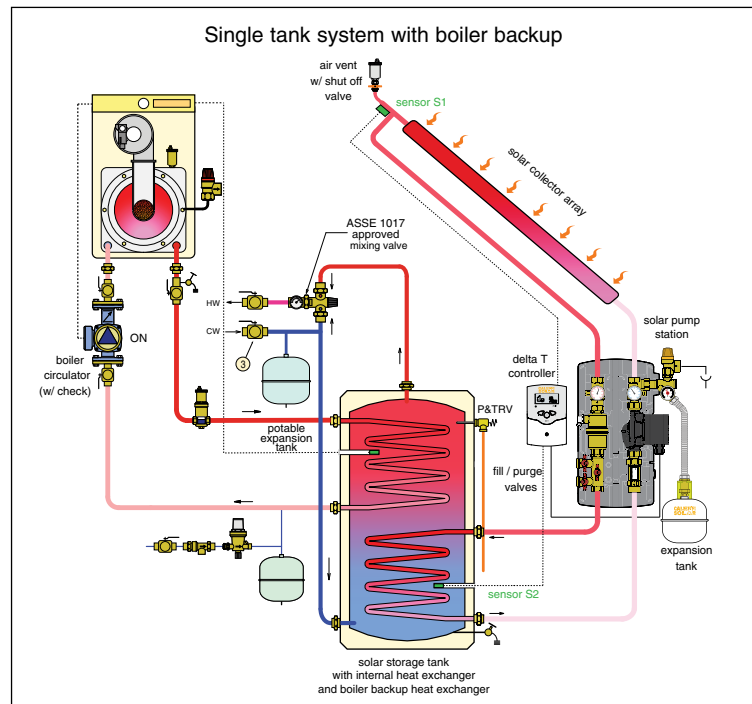
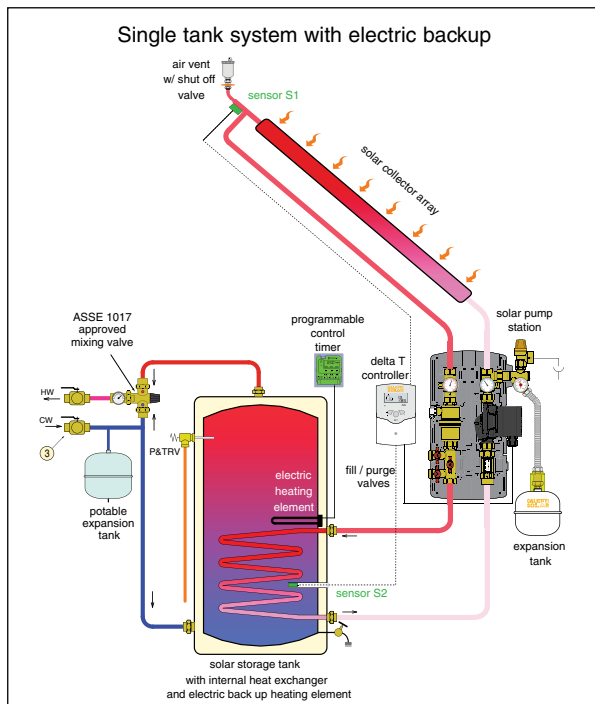

Figure 1: NAS20053, NAS20083, NAS20123

Figure 2: NAS20082, NAS20122, NAS20124

Model	A	B	C	D	E	F	G	H	I	J	K
NAS20053	22"	48 $\frac{1}{4}$ "	39 $\frac{3}{4}$ "	39 $\frac{3}{4}$ "	31 $\frac{1}{2}$ "	16 $\frac{3}{4}$ "	6 $\frac{1}{2}$ "	n/a	n/a	n/a	n/a
NAS20083	24"	64"	57 $\frac{1}{8}$ "	57 $\frac{1}{8}$ "	31 $\frac{1}{2}$ "	19 $\frac{1}{4}$ "	6 $\frac{1}{2}$ "	5"	n/a	n/a	n/a
NAS20123	28"	65"	57 $\frac{3}{4}$ "	57 $\frac{3}{4}$ "	33 $\frac{3}{4}$ "	16 $\frac{1}{4}$ "	8 $\frac{3}{4}$ "	6 $\frac{1}{2}$ "	n/a	n/a	n/a
NAS20082	24"	64"	57 $\frac{1}{8}$ "	57 $\frac{1}{8}$ "	49 $\frac{1}{2}$ "	46 $\frac{7}{8}$ "	36 $\frac{1}{2}$ "	31 $\frac{1}{2}$ "	19 $\frac{1}{4}$ "	6 $\frac{1}{2}$ "	5"
NAS20122	28"	65"	57 $\frac{3}{4}$ "	57 $\frac{3}{4}$ "	51 $\frac{3}{4}$ "	49 $\frac{1}{8}$ "	38 $\frac{3}{4}$ "	33 $\frac{3}{4}$ "	16 $\frac{1}{4}$ "	8 $\frac{3}{4}$ "	6 $\frac{1}{2}$ "
NAS20124	28"	65"	57 $\frac{3}{4}$ "	57 $\frac{3}{4}$ "	51 $\frac{3}{4}$ "	49 $\frac{1}{8}$ "	38 $\frac{3}{4}$ "	33 $\frac{3}{4}$ "	16 $\frac{1}{4}$ "	8 $\frac{3}{4}$ "	6 $\frac{1}{2}$ "

Application diagrams



Flexible stainless steel insulated piping SolarFlex

NA3500

**CALEFFI
SOLAR**



Function

SolarFlex is a system solution with pre-insulated flow and return pipes for solar hot water heating systems used to connect the solar collector with the storage tank in an easy, quick and professional way. It optimizes thermal efficiency of the entire system. The pre-insulation solution of two flexible stainless steel pipes inside two EPDM closed cell insulation and the integrated sensor cable, saves time and reduces cost of installation. SolarFlex is packaged in a 50-foot continuous coil with a complete range of accessories to ensure a smooth and secure installation.

General

- Easy to install, enabling pipes to be run without using a torch in confined spaces or on the roof.
- Ensures a leak-free installation.
- Easy to separate, without damaging the tubes.
- External copolymer foil protects against UV radiation and mechanical strain.
- Identification mark for flow and return.
- Meets highest requirements for modern solar heating systems.
- Pre-insulated feed and return pipes can be joined easily without special tools.

Product range

NA3520-15	1/2" SolarFlex pipe 50' coil including (2) double nipples, (4) union nuts, 4 segment rings and 4 washers
NA3540-15	3/4" SolarFlex pipe 50' coil including (2) double nipples, (4) union nuts, 4 segment rings and 4 washers
NA3540-B	3/4" SolarFlex pipe bulk cut to length up to 164 foot. Without connection fittings.
NA3560-15	1" SolarFlex pipe 50' coil including (2) double nipples, (4) union nuts, 4 segment rings and 4 washers

Technical specifications

Materials:

- pipe: two corrugated stainless steel 316L
- insulation: two closed cell elastomer UV resistance EPDM
- outer cover: UV resistant polyolefin copolymer foil

Insulation thickness: 5/8 inch (16mm)

Thermal conductivity: 0.215 BTU-in/hr-ft²-°F (0.031 W/mK)

Thermal resistance: R-4.2

Max. working pressure: 150 psi (10 bar)

Max. fluid temperature: 350°F (175°C)

Min. surface temperature: -60°F (-50°C)

Length per coil: 50 feet (15m)

Fluid capacity per foot:

1/2" - 0.0219 gallons (0.08 liters)

3/4" - 0.0346 gallons (0.13 liters)

1" - 0.0509 gallons (0.19 liters)

Min. bending radius: 5 inch (130mm)

Pressure loss: Approx. 25% more than in a comparable smooth pipe

Flammability: Class VO

Flame spread/smoke density: 25/50

Agency approvals: ASTM D 635

ASTM C 177

Dimensions

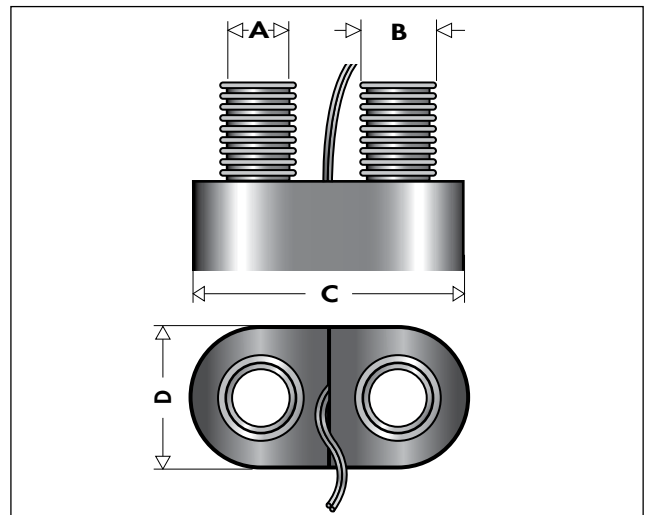

Code	A	B	C	D	Weight (lb/ft)
NA3520-15	1/2"	11/16"	4"	2"	0.4
NA3540-15	3/4"	15/16"	4 - 3/8"	2 - 1/8"	0.5
NA3560-15	1"	1 - 1/4"	4 - 7/16"	2 - 1/2"	0.7

Hydraulic characteristics

Feet of head curve for 1 foot of 1/2" SolarFlex

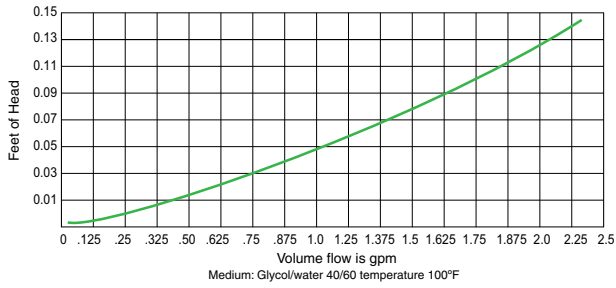

Feet of head curve for 1 foot of 3/4" SolarFlex

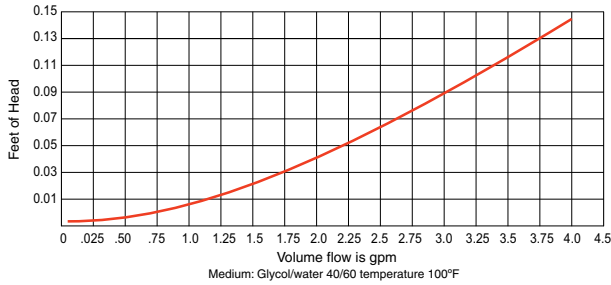

Feet of head curve for 1 foot of 1" SolarFlex

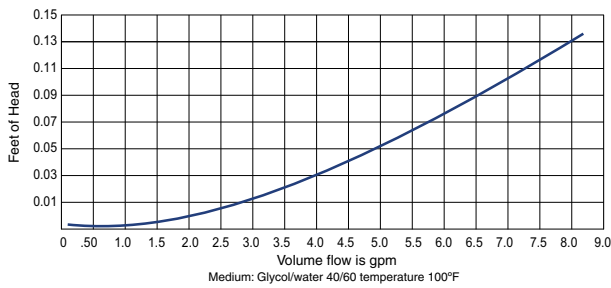

Construction details

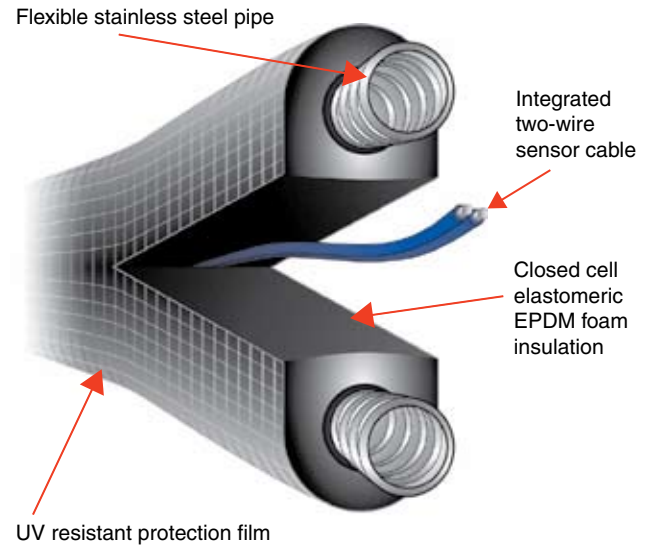

Flow and return pipes are easy to separate without damaging the insulation or sensor cable.

Item	Code	Description
SolarFlex pipe hangers		
	NA12132	Pipe hangers 1/2" pack of 4 hanger for 1/2" SolarFlex
	NA12133	Pipe hangers 3/4" pack of 4 hangers for 3/4" SolarFlex
	NA12134	Pipe hangers 1" pack of 4 hangers for 1" SolarFlex
SolarFlex extra connection kits		
	NA12102	Connection Kit for 1/2" SolarFlex with 4 nuts, 4 segment rings and 4 flat sealing washers
	NA12103	Connection Kit for 3/4" SolarFlex with 4 nuts, 4 segment rings and 4 flat sealing washers
	NA12104	Connection Kit for 1" SolarFlex with 4 nuts, 4 segment rings and 4 flat sealing washers
SolarFlex insulating tape		
	NA35001	Insulating EPDM foam tape (UV resistant) to wrap exposed piping, 50 ft roll x 2" wide x 1/8" thick
	NA35002	Black film tape (UV resistant) to wrap foam tape, 50 ft roll x 2" wide
	NA35007	Black braid sleeve (UV & Vermin resistant), to protect exposed split piping outside, (2) 4' braid with (1) 30 ft roll x 2" wide black film tape

Solar pump stations

series 255 & 256

CALEFFI
SOLAR



Function

Solar pump stations are used on the primary circuit of solar heating systems to control the temperature of the hot water storage. The pump inside the unit is activated by the signal from a differential temperature controller. The unit contains the functional and safety devices for an optimal circuit control, and is available with both flow and return connection or with return connection only.

General

The solar pump station is a pre-installed and leak-tested unit with fittings for transferring heat from the collector to the storage tank. It contains important fittings and safety devices for the operation of the solar thermal system:

- Ball valves in flow and return in combination with check valves to prevent gravity and thermo circulation.
- Ports for flushing, filling and emptying the system.
- Air vent for manual bleeding of the solar thermal system.
- Flow meter for displaying and setting the flow rate.
- Thermometer in flow and return for displaying both temperatures.
- Pressure gauge for displaying the system pressure.
- Safety relief valve to prevent overpressure.
- Three-speed solar pump for wide range of flow rates.

Product range

Code 255050A	Dual line pump station, 3 speed, flow and return connection, flow meter scale: 1/2–5 gpm	3/4" female
Code 255056A	Dual line pump station, without pump, flow and return connection, flow meter scale: 1/2–5 gpm	3/4" female
Code 256050A	Single line pump station, 3 speed, return connection, flow meter scale: 1/2–5 gpm	3/4" female
Code 256056A	Single line pump station, without pump, return connection, flow meter scale: 1/2–5 gpm	3/4" female

Technical specifications

Body:	brass
Temperature gauge:	steel / aluminium
Seals:	PTFE / EPDM
O-Rings:	EPDM / Viton
Union gaskets:	AFM 34, asbestos free
Insulating shell:	EPP, thermal conductivity value = R4

Pump

Wilo solar model:	Star S-16 U15
Body:	cast iron
Power supply:	115 V - 60 Hz
Max. pressure:	150 psi (10 bar)
Max. temperature:	230°F (110°C)
Agency approval:	cULus

Performance

Medium:	water, glycol solutions
Max. percentage of glycol:	50%
Max. working temperature:	360°F (180°C)
Max. working pressure:	150 psi (10 bar)
Safety relief valve temperature range:	-20 to 360°F (-30 to 180°C)
Safety relief valve factory setting:	90 psi (6 bar)
Min. opening pressure for check valve:	Δp : 1/4 psi (2 kPa)
Adjustment range of flow meter:	1/2 to 5 gpm (1 to 20 l/min)
Max return flow meter temperature:	265°F (130°C)
Pressure gauge scale:	0–90 psi (0–6 bar)
Temperature gauge scale:	32–320°F (0–160°C)
Connections:	3/4" female straight thread
Filling/drain hose connections:	3/4" male hose thread
Expansion tank connection:	1/2" male straight thread

Wilo Star S-16 U15 hydraulic characteristics

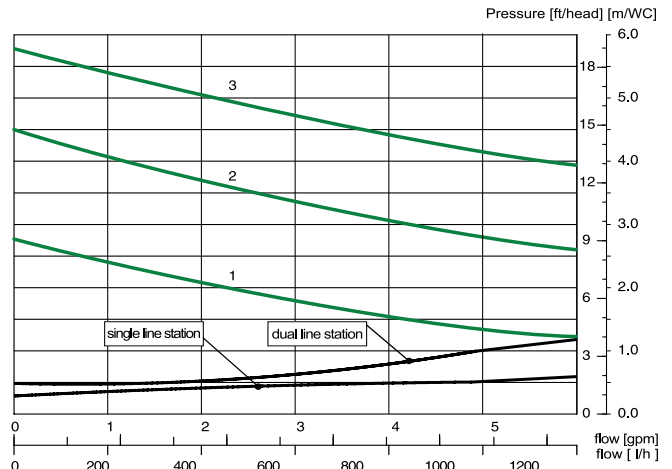

Dimensions

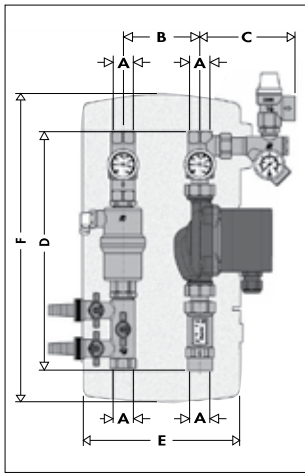

Code	A	B	C	D	E	F	Weight (lb)
255050A	3/4"	4"	4 7/8"	15"	8"	16"	13
255056A	3/4"	4"	4 7/8"	15"	8"	16"	10

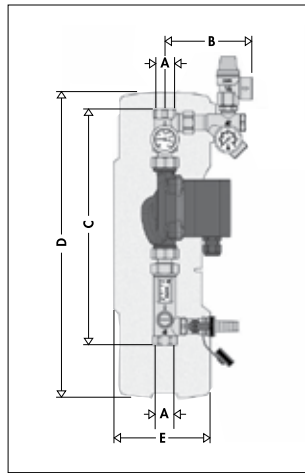

Code	A	B	C	D	E	Weight (lb)
256050A	3/4"	7"	16 1/4"	17"	5"	12
256056A	3/4"	7"	16 1/4"	17"	5"	8

Characteristic components

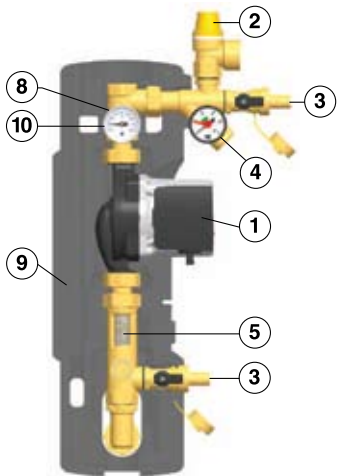
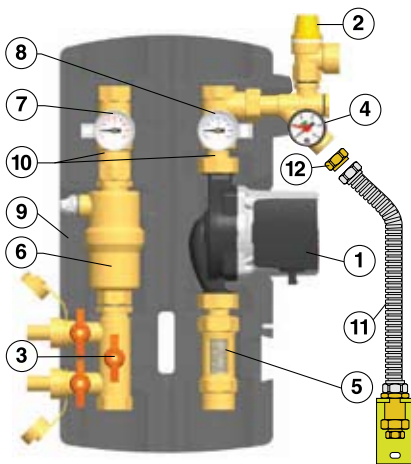

- 1 Wilo-Solar circulation pump
- 2 Safety relief valve 253 series
- 3 Filling/drain valve
- 4 Pressure gauge
- 5 Flow meter
- 6 Air trap and vent
- 7 Flow temperature gauge
- 8 Return temperature gauge
- 9 Pre-formed insulation shell
- 10 Shut-off and check valve
- 11 Expansion Tank connection kit
- 12 3/4" cap (used if no expansion tank is installed)

Construction details

Shut-off and check valve

The shut-off and check valves are built into the ball valves of the temperature gauge connectors.

- A. In normal system operation, the ball valves must be fully open.
- B. To allow the fluid to flow in both directions, it is necessary to rotate the respective ball valve to 45°.
- C. To close ball valve, rotate 90°.

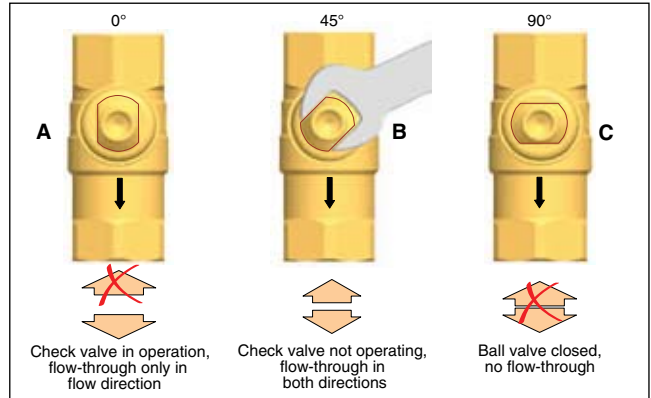

Air vent

The solar pump unit version with flow and return connection is equipped with an air vent on the flow line. The air, separated from the fluid, is collected at the top of the vent.

The collected air must be released from time to time—every day after the initial installation; however, it can eventually be done weekly or monthly, depending on the quantity of the air. The collected air is released using the manual air vent with a screwdriver.

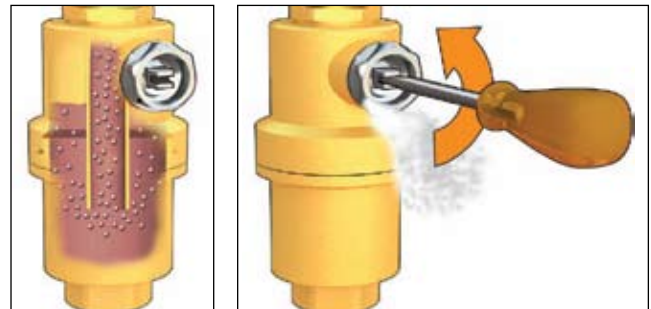

Flow meter

The Flow meter is for measurement and display of the flow rate of 1/2 to 5 gpm (1-20 l/min). For accurate function of the measuring device the system must be flushed and free from foreign substances.

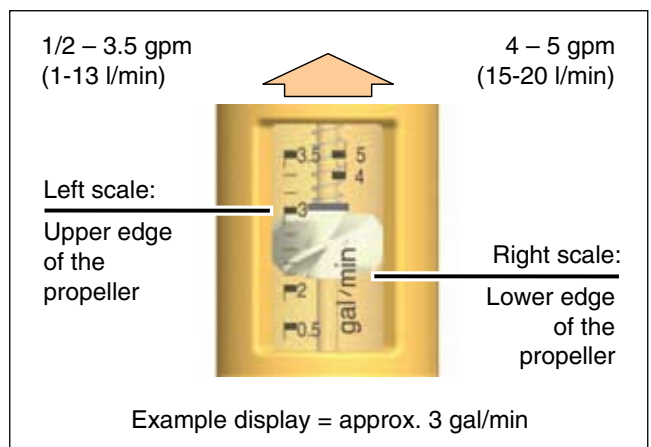

Solar pump stations

series NA255

CALEFFI
SOLAR



Function

Solar pump stations are used on the primary circuit of solar heating systems to control the temperature of the hot water storage. The pump inside the unit is activated by the signal from a differential temperature controller. The unit contains the functional and safety devices for an optimal circuit control, and is available with both flow and return connection or with return connection only.

General

The solar pump station is a pre-installed and leak-tested unit with fittings for transferring heat from the collector to the storage tank. It contains important fittings and safety devices for the operation of the solar thermal system:

- Ball valves in flow and return in combination with check valves to prevent gravity and thermo circulation.
- Ports for flushing, filling and emptying the system.
- Air vent for manual bleeding of the solar thermal system.
- Flow meter for displaying and setting the flow rate.
- Thermometer in flow and return for displaying both temperatures.
- Pressure gauge for displaying the system pressure.
- Safety relief valve to prevent overpressure.
- Three-speed solar pump for wide range of flow rates.

Product range

Code NA255160 Dual line pump station, 3 speed, flow and return connection, flow meter scale: 1–10 gpm _____ 1" male

Technical specifications

Body:	brass
Temperature gauge:	steel / aluminium
Seals:	PTFE / EPDM
O-Rings:	EPDM / Viton
Union gaskets:	AFM 34, asbestos free
Insulating shell:	EPP, thermal conductivity value = R4

Pump

Wilo solar model:	Star S-30 U25
Body:	cast iron
Power supply:	115 V - 60 Hz
Max. pressure:	150 psi (10 bar)
Max. temperature:	230°F (110°C)
Agency approval:	cULus

Performance

Medium:	water, glycol solutions
Max. percentage of glycol:	50%
Max. working temperature:	360°F (180°C)
Max. working pressure:	150 psi (10 bar)
Safety relief valve factory setting:	90 psi (6 bar)
Min. opening pressure for check valve:	0.66 ft head (0.2 mWC)
Adjustment range of flow meter:	1 to 10 gpm (4 to 38 l/m)
Max return flow meter temperature:	265°F (130°C)
Pressure gauge scale:	0–90 psi (0–6 bar)
Temperature gauge scale:	32–320°F (0–160°C)
Connections:	1" male thread
Filling/drain hose connections:	3/4" male

Wilo Star S-30 U25 hydraulic characteristics

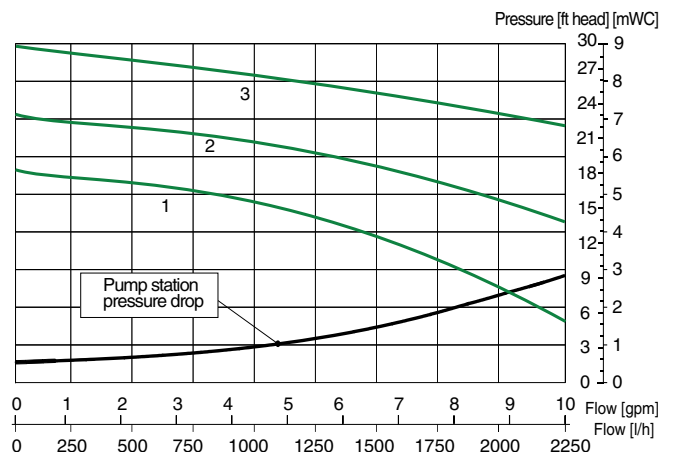

Dimensions

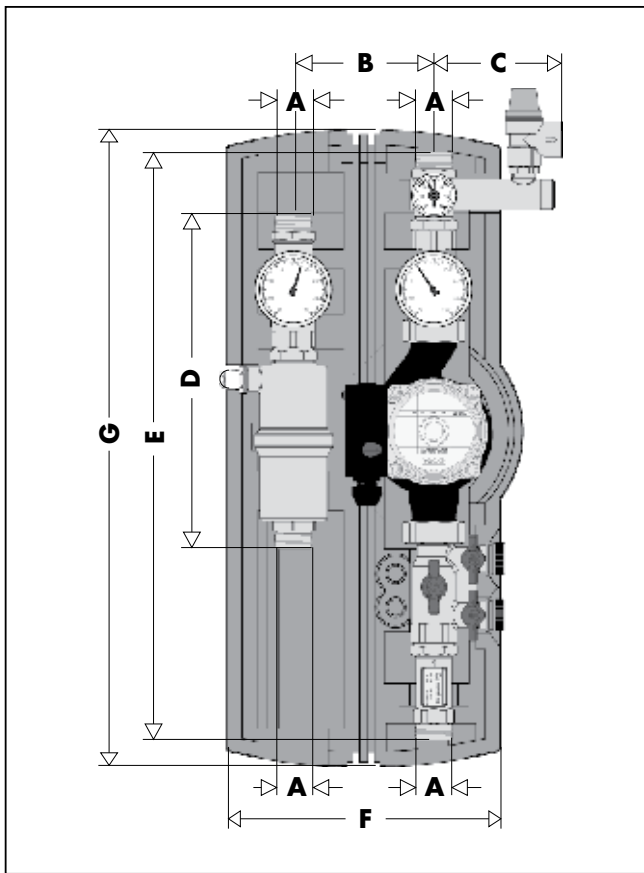

Code	A	B	C	D	E	F	G	W (lb)
NA255160	1"	4 7/8"	4 1/2"	11 1/2"	20 1/2"	9 5/8"	22 1/2"	20

Characteristic components

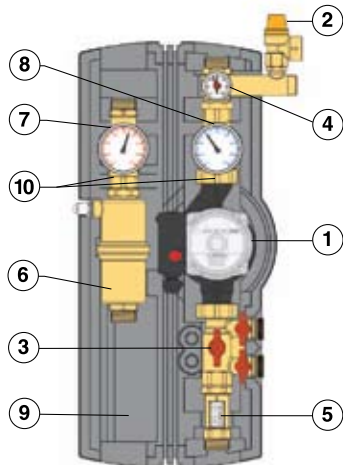

- | | |
|----------------------------------|-------------------------------|
| 1 Wilo-Solar circulation pump | 6 Air trap and vent |
| 2 Safety relief valve 253 series | 7 Flow temperature gauge |
| 3 Filling/drain valve | 8 Return temperature gauge |
| 4 Pressure gauge | 9 Pre-formed insulation shell |
| 5 Flow meter | 10 Shut-off and check valve |

Construction details

Shut-off and check valve

The shut-off and check valves are built into the ball valves of the temperature gauge connectors.

- A.** In normal system operation, the ball valves must be fully open.
- B.** To allow the fluid to flow in both directions, it is necessary to rotate the respective ball valve to 45°.
- C.** To close ball valve, rotate 90°.

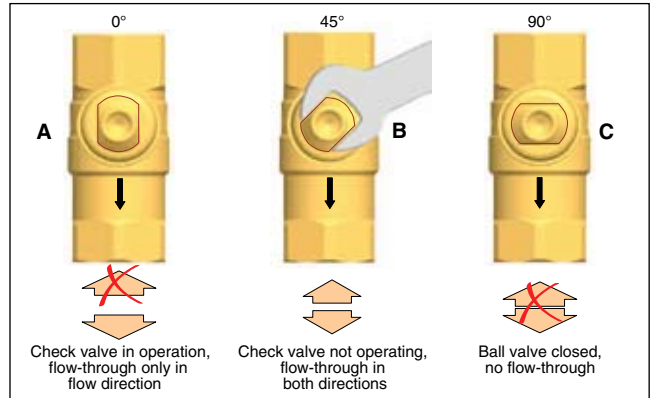

Air vent

The solar pump unit version with flow and return connection is equipped with an air vent on the flow line. The air, separated from the fluid, is collected at the top of the vent.

The collected air must be released from time to time—every day after the initial installation; however, it can eventually be done weekly or monthly, depending on the quantity of the air. The collected air is released using the manual air vent with a screwdriver.

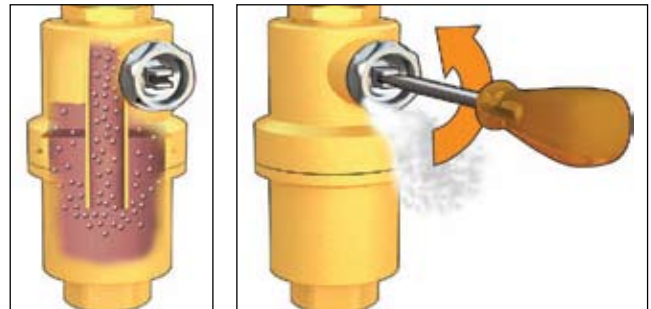

Flow meter

The Flow meter is for measurement and display of the flow rate of 1 to 10 gpm (4 to 38 l/m). For accurate function of the measuring device the system must be flushed and free from foreign substances.

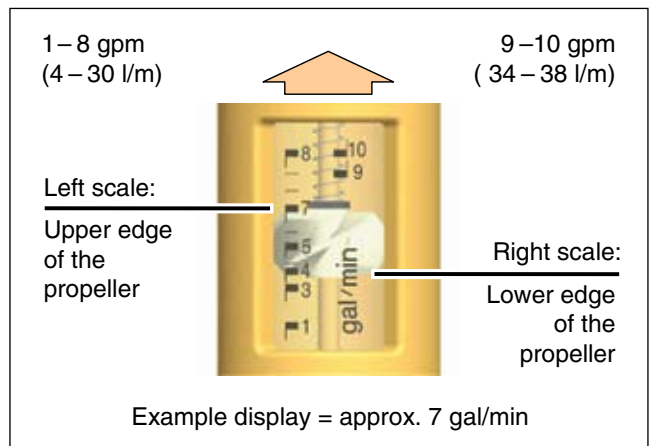

DC-EMC solar pump

NA26711

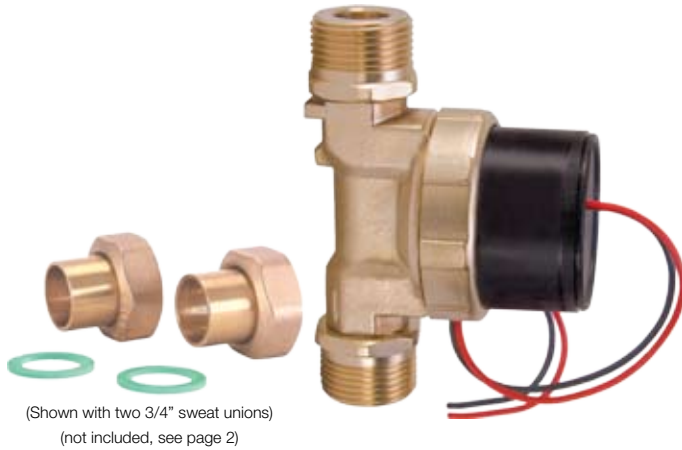

Application

The DC-ECM solar pump can be used for most circulation pump applications without connection to the power grid. Highly efficient, the DC-ECM solar pump can be connected directly to a photovoltaic panel and is characterized by its small size, high efficiency, and extremely low power consumption. The shaftless spherical motor technology provides maintenance free and provides quiet service and maintenance free life.

This pump is ideal for single family home thermal solar systems or any circulation pump application where conventional power is not available.

Product range

Code: NA26711 DC-ECM solar pump operates on 8 to 25 VDC.....1" male union thread

Technical specification

Materials

Pump body: brass
 Bearing: ceramic ball
 Seals: EPDM
 Impeller: wet rotor
 Motor: permanent magnet ECM

Performance

Voltage: 8 - 25 VDC
 Power consumption: 3 - 55W
 Current draw: 0.13 - 2.1 A
 Insulation class: IP 42 / Class F
 Suitable fluids: water, glycol solution
 Max percentage of glycol: 50%
 Max. working pressure: 150 PSI (10 bar)
 Max. temperature: -10° F to 230° F (-10 to 110°C)
 Flow rates:
 12V up to 5 gpm (19 lpm)
 24V up to 7 gpm (26.5 lpm)
 Pump head:
 12V up to 10 ft (3.0 m)
 24V up to 15 ft (4.6 m)

Connections: 1" male union half threads
 Face to face dimension: 5 1/8"(130 mm)

Dimensions

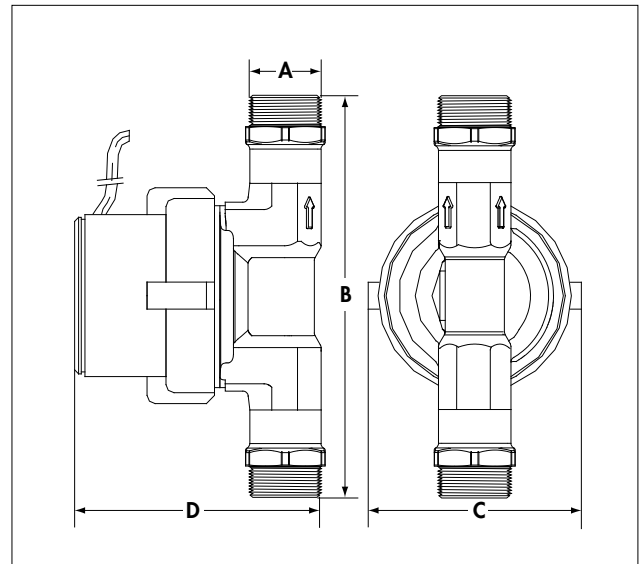

Code	A	B	C	D	Weight (lb)
NA26711	1"	5 1/8"	3 1/8"	3 1/4"	3.0

Hydraulic characteristics

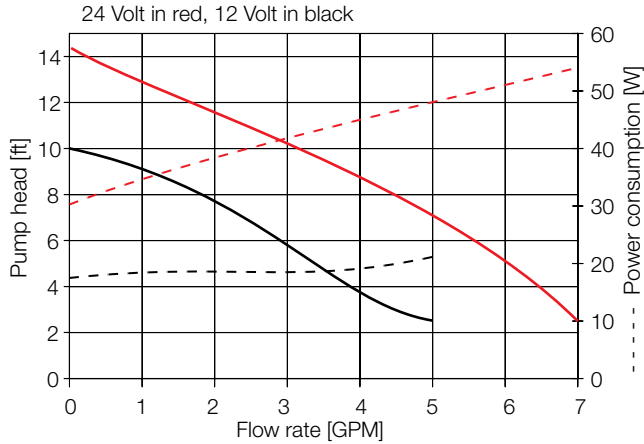

Operating principle

The single moving part in a spherical motor is a hemispherical rotor/impeller unit. The rotor/impeller rides on an ultra-hard, wear-resistant ceramic sphere. There are no conventional shaft bearings or seals. This eliminates the possibility of bearing-play which is commonly associated with increased noise and the seal-less design eliminates a potential leak path. These pumps are particularly robust and provide an exceptionally long service life in excess of 50,000 hours. The self-aligning bearing is lubricated and cooled by the fluid media. Maintenance is not necessary under normal conditions. Even after lengthy shutdown periods a reliable start-up is virtually guaranteed. Parts exposed to the fluid are completely corrosion resistant even with aggressive fluids.

Construction design

The pump housing brass is for use in both solar systems and potable water. The pump motor is fixed to the pump housing by the screw ring, which enables easy removing and disassembly. The motor has electronic integrated thermal overload protection, interference suppressor and integrated reverse polarity protection. Power cord double-wire is red/black for polarity. The pump motor and the integrated electronic parts are moisture resistant.

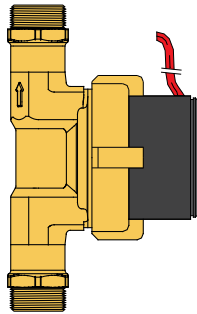

Integrated overtemperature protection

The pump comes with an integrated overtemperature safety device, which shuts the pump electronics off when reaching overtemperature. A complete shutdown after reaching an overtemperature condition can result in adverse effects on the solar system. Since the temperature of the electronic components is influenced by the temperature of the pumped media, the pump will lower its speed automatically after reaching a critical temperature level in order to avoid a total system shutdown. However, if the temperature continues to rise because of too hot of pumped media, the pump will eventually shut down completely. After cooling down, the pump will restart automatically.

Installation

The pump can be fitted either vertically or horizontally, with the motor in any position, except the motor up.

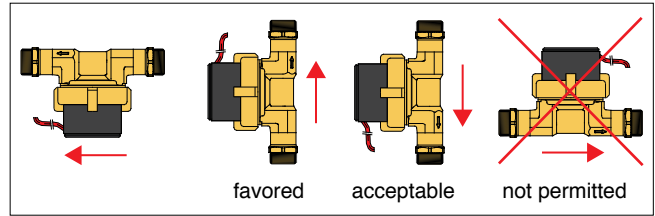

Electrical connection

Important note: Electrical installations may only be performed by a properly licensed electrician observing all applicable general and local codes.

- Connect to a 8-25 V co-current flow power supply, the red wire has to be connected with positive terminal, the black wire has to be connected with the negative terminal.
- If the system is not filled with water yet, reduce the time of a function test to an absolute minimum. Extended dry operation of the pump will damage the bearing.

Before startup

Flush the system to remove dirt, make sure the system is filled and the air has been purged. The pump can be switched on. If you hear air noises initially, these should stop after a short time. Power cycling the pump several times accelerates the air removal. If the air noise does not disappear or at least decrease substantially, repurge the system. Avoid dry run in any case, this will damage the pump.

Startup

- The starting current is much higher than the operating current for a very short time until the pump is running.
- If the voltage drops because of the high starting current, the pump will startup.

Pump station installation



The DC-ECM solar pump is a direct fit into the 255 and 256 series solar pump stations. The DC pump face to face dimensions and the male union thread are exactly the same 120V version. Simply select the 255 or 256 solar pump station configured without the pump. To install, remove the pump space pipe and mount the DC-ECM directly with the union half nuts. The iSolar 12V and 24 VDC controllers will fit into the front insulation cover of the 255 and 256 series pump station.

In-line sweat fittings

Item	Code	Description
	255056A	Dual-line solar station without pump
	256056A	Single-line solar station without pump
	NA10002	1/2" sweat tail piece, use nut and washer
	NA10003	3/4" sweat tail piece, use nut and washer
	R50055	Sealing washer, use with nut and tail piece
	R61008	Union nut 1" thread, use washer, tail piece
	59834A	1" sweat tail piece with nut, use washer

Differential temperature controllers

iSolar

series 257

CALEFFI
SOLAR



Function

The iSolar series solar thermal controllers are multi-functional temperature differential controllers that provide complete control of the solar thermal system for safe and long-lasting operation. The iSolar microprocessor controller monitors and controls thermal solar energy systems by means of a collector sensor and a storage tank sensor. The controllers also implements important system monitoring and safety functions. The system parameters and measured values can be viewed and altered by the large LCD display. The controller is equipped for up to four temperature sensor inputs and one or two outputs (some models) for activating the solar circuit pump and second output for activating a valve or second pump.



Tested and Approved by TÜV Rheinland as an approved U.S. Nationally Recognized Testing Laboratory (NRTL) Exceeds or is equivalent to:
UL 60730-1A
CAN/CSA E60730-1

Product range

Code 257210A	iSolar 1 with 1 pump control relay, includes 2 temperature sensors, data connection
Code 257220A	iSolar 2 with 1 pump speed control triac, includes 2 temperature sensors, data connection
Code 257230A	iSolar 3 with 2 control relays for solar pump and second pump or valve, includes 2 sensors, data connection
Code 257240A	iSolar 4 with 1 pump speed triac and 1 control relay for second pump or valve, includes 2 sensors, data connection
Code 257260A	iSolar Plus with 2 pump speed triacs, for second pump or valve, includes 4 sensors, data connection
Code 257260A PV1	iSolar Plus 12V with 2 pump control relay, for second pump or valve, includes 4 sensors, data connection
Code 257260A PV2	iSolar Plus 24V with 2 pump control relay, for second pump or valve, includes 4 sensors, data connection

Technical specifications

Housing plastic:	PC-ABS
Protection type:	Indoor only
Mounting:	wall or in 255 series pump station
Display:	LCD with symbols and text
Interface:	three soft push buttons
Inputs:	4 temperature sensors
Outputs:	1 or 2 triac or standard relays
Switching relay capacities:	1 (1) A 115VAC
Power supply:	115 VAC – 60 Hz 12V – 24V
Power consumption:	1W, 1.5VA
Data connection:	V-Bus

Performance

ΔT adjustment range:	2–40° ΔT (1–20°K)
Min. temperature differential:	2° ΔT (1°K)
Hysteresis:	2° ΔT, ± 1° ΔT (1°K, ± .5°K)
Max. tank temperature range:	35–205°F (2–95°C)
Max. collector temperature range:	210–375°F (100–190°C)
Emergency shut down of the collector:	230–395°F (110–200°C)
Min. collector temperature range:	50–195°F (10–90°C)
Antifreeze temperature option:	15–50°F (-10–10°C)
kWh (BTU) flow input:	0–5 gpm (0–20 lpm)
Agency approvals:	cTUVus

Temperature sensors

Platinum RTD type:	1,000 ohm
Collector sensor working range:	-58–355°F (-50–180°C)
Tank sensor working range:	15–175°F (-10–80°C)
Length of collector black cable:	60 in. (1.5 m)
Length of tank sensor gray cable:	95 in. (2.5 m)

Resistance values for sensors subject to the temperature

°F	14	23	32	41	50	59	68	77	86
Ω	961	980	1000	1019	1039	1058	1078	1097	1117
°F	95	104	113	122	131	140	149	158	167
Ω	1136	1155	1175	1194	1213	1232	1252	1271	1290
°F	176	185	194	203	212	221	230	239	248
Ω	1309	1328	1347	1366	1385	1404	1423	1442	1461

Dimensions

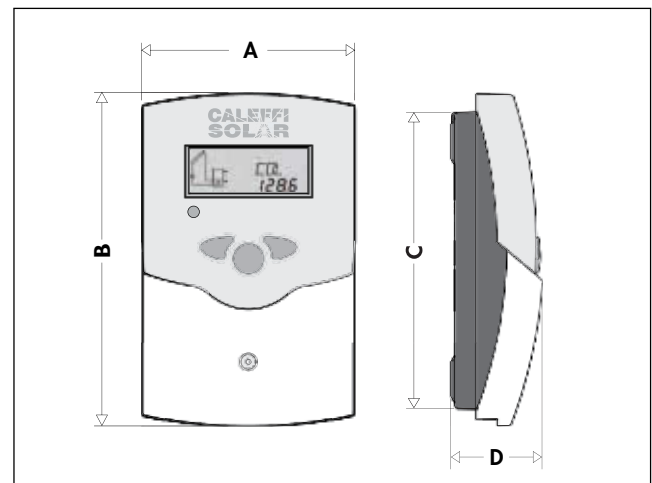

Code	A	B	C	D	Weight (lb)
257series	4 3/8"	6 3/4"	6"	2"	0.9

Characteristics

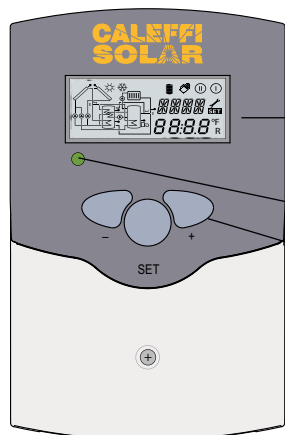

User-friendly operation

- System screen LCD display with 16-segment display and 8 symbols for system status
- Operating LED control lamp
- 3 push-button controls
- Attractive design and compact dimensions
- Easy to install

Pump speed control functions (iSolar 2, 4 & Plus)

Pump speed control can improve system efficiency by reducing the flow to the collectors on cloudy days to improve solar thermal transfer and reduce electrical consumption. This is achieved by the differential temperature value between the collectors and storage tank.

If the value for the ΔT switch-on is reached (e.g. ΔT on = 9°), the pump will start with 100% pump speed for 10 seconds, then reduce the speed to the adjusted minimum pump speed (min. pump speed = 30 %, adjustable). If the temperature difference reaches the set value (e.g. ΔT Set = 18°), pump speed will increase by 10 %. At any further rise of $3^\circ \Delta T$ the pump speed will increase by 10% until the maximum of 100% is reached.

Standard operation functions

	iSolar 1 120V	iSolar 2 120V	iSolar 3 120V	iSolar 4 120V	iSolar Plus 120V	iSolar Plus PV 12 or 24V
Selectable programs	1	1	3	3	10	10
Standard relay output	1	0	2	1	0	2
Speed control triac output (30 to 100%)	0	1	0	1	2	0
Sensor inputs (temperature)	4	4	4	4	4	4
Max. solar collector arrays	1	1	1	1	2	2
Max. solar storage tanks	1	1	1	1	2	2
Two tank priority logic	no	no	no	no	yes	yes
Second deltaT-function	no	no	no	no	yes	yes
Drainback pump speed control	no	yes	no	yes	yes	no
Drainback booster pump (second relay)	no	no	yes	yes	yes	yes
Thermostat function (second relay)	no	no	yes	yes	yes	yes
Backup heat function (second relay)	no	no	yes	yes	yes	yes
Heat dump function (second relay)	no	no	yes	yes	yes	yes
Real time clock (timer function)	no	no	yes	yes	yes	yes
Collector freeze protection	yes	yes	yes	yes	yes	yes
Evacuated tube collector function	yes	yes	yes	yes	yes	yes
Min. collector temperature	yes	yes	yes	yes	yes	yes
Collector cooling functions	yes	yes	yes	yes	yes	yes
Tank (night time) cooling	yes	yes	yes	yes	yes	yes
Emergency shutdown functions	yes	yes	yes	yes	yes	yes
Operating hours counter	yes	yes	yes	yes	yes	yes
Energy metering measurement	yes	yes	yes	yes	yes	yes
Vbus data communication	yes	yes	yes	yes	yes	yes
Code	257210A	257220A	257230A	257240A	257260A	257260A PV1 or PV2

Sensor protection

SP10



Function

The SP10 sensor protection device should be used to protect the sensitive collector temperature sensor against external over-voltages. In the case of thunderstorms, lightning strikes can destroy the collector sensor and differential temperature controller. The SP10 protector diodes limit these over-voltages and maintains a stable noise-free connection between sensor and controller.

The best way to protect the collector sensor is to install the SP10 device close to the collector sensor. The SP10 is designed as a weather-resistant connecting terminal block in a dripping water-protected housing which can be used outdoors. Soft thermoplastic elastomers in the bottom of the lower housing protects the sensor cables and allow easy installation.

Product range

Code NA15006 SP10 sensor protection device for protecting collector sensor and controller from lightning or other over-voltages

Technical specifications

Upper housing:	ASA thermoplastic
Lower housing:	thermoplastic elastomers
Protection type:	NEMA 4 (IP 65)
Ambient temperature:	-15 ... 160°F (-25 ... +70°C)
Mounting:	vertically
Agency approvals	CE

Dimensions

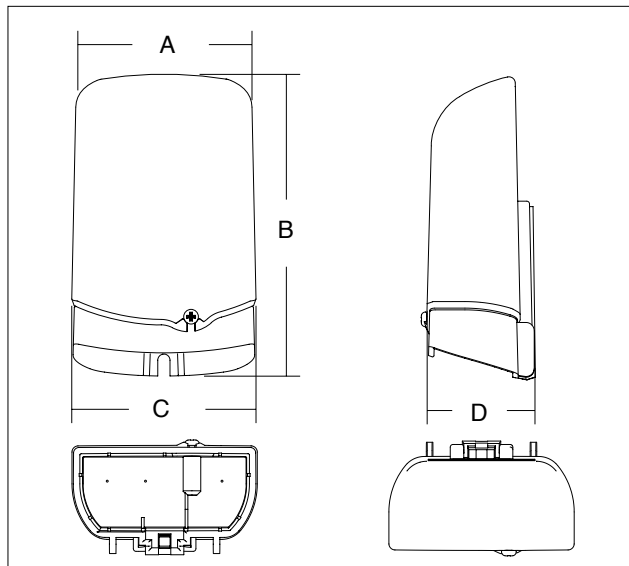

Code	A	B	C	D	Weight (lb)
NA15006	2 1/2"	4 3/8"	2 5/8"	1 1/2"	0.3

Mounting

For optimum protection against moisture, the SP10 sensor protection device must be fitted vertically. Unscrew the housing screw and remove the upper part of the housing. Mark the fastening points on vertical surface and drill. Attach the lower part of the housing using the screws. Install the upper part of the housing onto the lower part and attach housing screw.

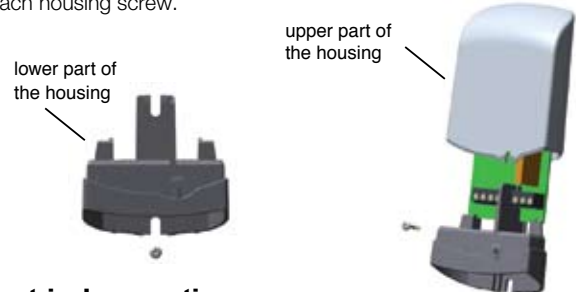

Electrical connection

Pierce the lower housing with a pointed object (fig.1). Insert the cables into the holes and pull them slightly back, such that the edge of the material is slightly turned to the outside. Thus the device is protected against moisture. Connect the sensor cable to the terminals 1 and 2 with either polarity (fig. 2). Connect the cable which leads to the controller at the terminals 3 and 4 and to the corresponding controller terminals.

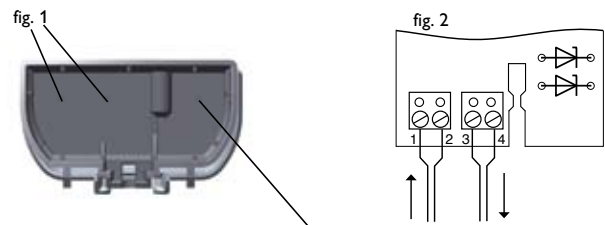

Note: If the connecting box is used outdoors, it is recommended to pierce a condensation water hole at the bottom after the device has been installed.

Alarm module

AM1



Function

The AM1 alarm module is designed to signal system failures. It is connected to the VBus data connection of the iSolar controllers and issues an optical signal via the red Flash-LED if a failure has occurred. The AM1 also has a dry contact output relay, which can be connected to an additional signaling device or to a building management system. Thus, a multi-modal error message can be issued in the case of a system failure.

Depending on which iSolar controller and the sensors connected, different fault conditions can be signaled. For example sensor failures, excess system temperature, excess collector or tank temperature, as well as errors in the flow rate, such as a dry run of the pump. The AM1 ensures that occurring failures can be immediately recognized and repaired, even if the system and the controller are difficult to access or located in a remote place.

Product range

Code NA15009 AM1 alarm module with red Flash-LED light and one dry contact output relay

Technical specifications

Housing plastic:	PC-2207 UV
Protection type:	Indoor only
Ambient temperature:	-15 ... 160°F (-25 ... 70°C)
Mounting:	wall
Display:	1 Red LED
Interface:	VBus data connection
Power supply:	VBus
Outputs:	1 dry contact relay
Switching relay capacities:	1 A, 24V AC/DC
Agency approvals	CE

Operating sequence

When the AM1 is operational, the LED will glow continuously to signal operational readiness. If the LED does not glow, check the connection of the device. The AM1 receives the VBus data packets of the device connected. In the case of a failure signal, the integrated Flash-LED flashes and the AM1 activates the dry contact output relay. The relay can be used to connect an additional signaling device, or to a building management system.

Data communication example

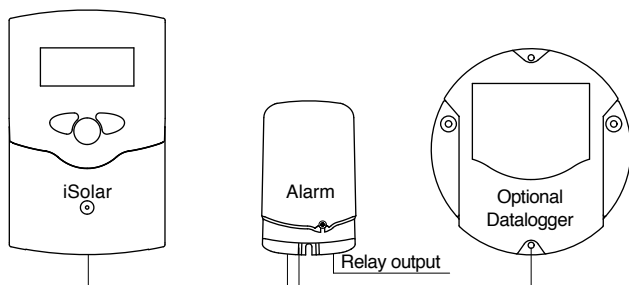

Dimensions

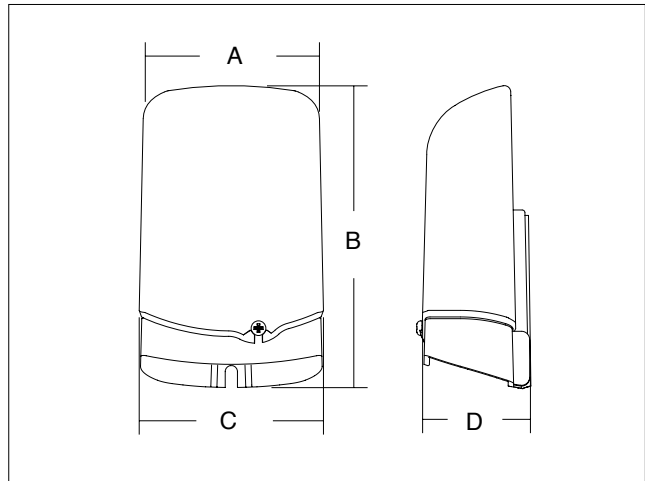

Code	A	B	C	D	Weight (lb)
NA15009	2 1/2"	4 3/8"	2 5/8"	1 1/2	0.3

Data connections

The AM1 is designed for easy connection to all iSolar controllers through the VBus data connection. Connect VBus wires to the terminals marked "VBus" with either polarity. The bus wire can be extended with two conductor wire (bell wire). The wire must be at least 20 AWG (0.5 mm²) and can be extended up to 150 feet. To the "Relay" terminals, a load can be connected with either polarity.

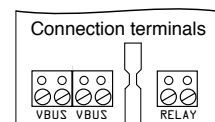

Energy meter

WMZ-G1



Function

The WMZ-G1 is an energy meter for thermal solar systems and conventional heating systems. The WMZ-G1 calculates energy by integrating flow rate and temperature from a Vortex Flow Sensor (VFS) Grundfos Direct Sensors™ and temperature difference in the flow and return piping using a Relative Pressure Sensor (RPS) Grundfos Direct Sensors™. The calculated heat energy value is displayed in kWh (kilowatt hours) and stored. A power failure protection guarantees that the adjusted system parameters and the calculated heat energy quantity are maintained in the case of power loss.

Grundfos Direct Sensors™ Technology

The VFS combines the established vortex principle with the direct exposure of the sensor chip to the media gives a superior sensitivity and fast response. The VFS sensor detects the pressure pulsation generated by the vortices and converts the pulsation and temperature into an electrical output signal. The VFS sensor has shown to be 5 times higher in accuracy with faster flow response than most common turbine flow meters. The RPS sensor transforms the pressure and temperature of the medium into electrical signals. The pressure signals are linearized to compensate for temperature variations.

Product range

- Code 257202A WMZ-G1 Heat energy meter functions with VFS flow/temperature sensor and RPS pressure/temperature sensors
- Code NA15014 RPS Grundfos Direct Sensors 2 in 1 Pressure / temperature sensor 0 - 150 psi / up to 250° F, includes connecting wire
- Code NA15015 VFS Grundfos Direct Sensors 2 in 1 Flow / temperature sensor 1/4 - 3 gpm / up to 250° F, includes connecting wire
- Code NA15016 VFS Grundfos Direct Sensors 2 in 1 Flow / temperature sensor 1/2 - 10 gpm / up to 250° F, includes connecting wire

Technical specifications

WMZ-G1 energy meter

Housing plastic:	PC-ABS
Display:	4 lines LCD
Inputs:	2 Grundfos Direct Sensors
Output:	1 relay
Switching relay capacities:	2 (1) A 24V=
Interface:	VBus data connection
Power supply:	24V AC or DC

Vortex Flow Sensor (VFS)

Flow measuring range:	NA15015 0.25 - 3 gpm (1-12 lpm)
	NA15016 0.50 - 10 gpm (2-40 lpm)
Flow accuracy:	1.5%
Flow response time:	< 1 sec.

Relative Pressure Sensor (RPS)

Pressure measuring range:	0 - 150 psi (0-10 bar)
Pressure accuracy:	2% FS
Pressure response time:	< 1 sec.

VFS and RPS temperature specifications

Max. fluid temperature:	250° F (120°C)
Temperature accuracy range:	32 - 210° F (0-100°C)
Temperature accuracy:	2%
Temperature response time:	< 1sec.
Suitable fluids:	water, glycol solution
Max percentage of glycol:	50%
Materials:	- Body: brass
	- Seals: EPDM
	- Sensor housing: composites (PPS, PA66)
Connection:	1" male union thread
Optional separate fittings:	1/2", 3/4" & 1" sweat tail pieces and union nuts

The trademark Grundfos Direct Sensors™ is owned and controlled by the Grundfos group.

System diagram

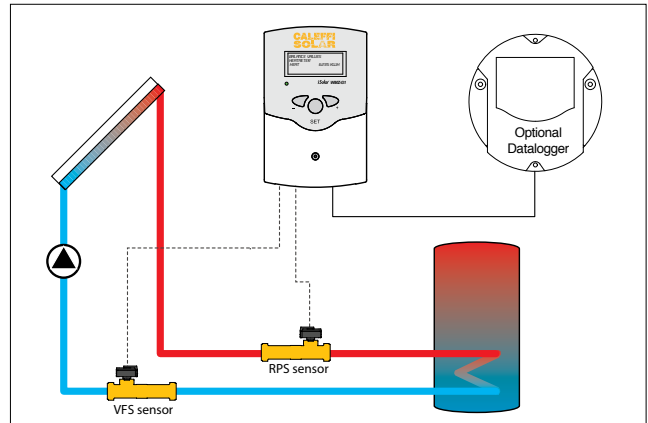

Multinode network

Additional WMZ-G1 energy meters can be cascaded together on the VBus connection. One WMZ-G1 is configured as the master and additional WMZ-G1 meters are configured as slaves. Up to 16 meters can be cascaded together with two conductor wire (bell wire) at least 20 AWG and up to 150 feet for transmission of data values to a connected PC or DL2 datalogger.

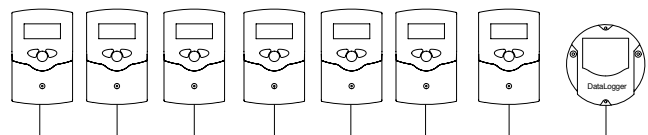

The connection sequence is arbitrary, up to 16 can be cascaded together

DataLogger

DL2



Function

The DL2 data logger enables the acquisition and storage of large amounts of data (such as energy metering and recorded values of the solar system) over a long period of time when connected to an iSolar controller. The DL2 is compatible with all iSolar controllers with VBus data connection terminals and is connected to the VBus with two conductor wire (bell wire) at least 20 AWG up to a distance of 150 feet.

The DL2, when connected to a network through the integrated ethernet socket, can be configured and viewed with any standard internet browser via its integrated web interface. A configuring IP address and password protection allows for access from any PC with an internet connection for system monitoring of energy metering or for reviewing system performance, without additional software. Download data through the web interface or an SD memory card for further data processing in spreadsheet programs

Product range

Code 257201A DL2 data logger connects to VBus data terminals on iSolar controllers

Technical specifications

Housing:	PC-ABS Thermoplastic
Protection type:	indoor
Ambient temperature:	32 ... 100° F (0 ... 40° C)
Mounting:	wall
Display:	bar LED
Input voltage:	5V DC ±5%
Power voltage adapter:	100 ... 240 V~
Rated current:	350 mA
Ethernet connection:	integrated socket
Data access	integrated SD slot
Memory:	180 MB internal memory

Connection

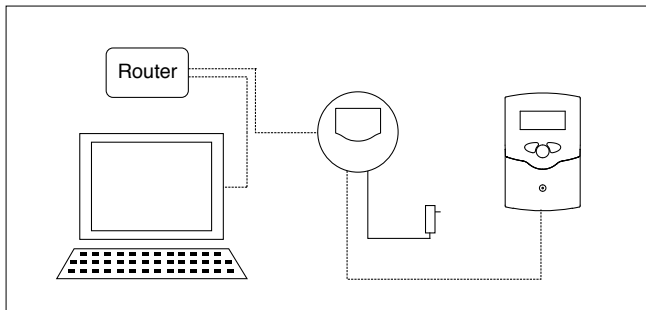

Dimensions

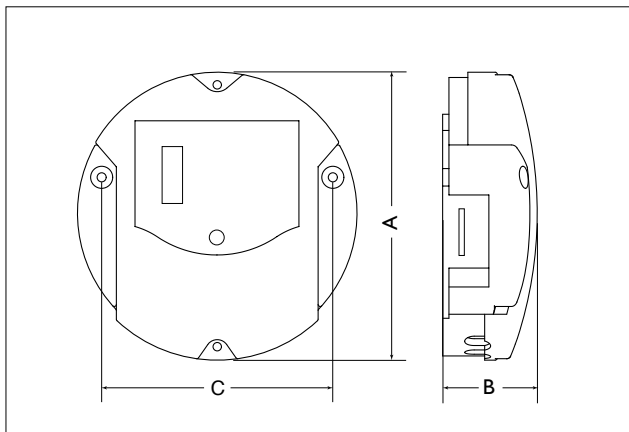

Code	A	B	C	Ø	Weight (lb)
257201A	5 1/8"	1 3/4"	4 7/16"	1/4" mount	3.0

Integrated Web interface



CALEFFI SOLAR



Solar Flat Plate Collectors

- 25,000, 32,000 & 40,000 Btu/day (SRCC Cat. C)
- Universal mounts for flush roof or ground mount.
- Durable, 1/8", low iron tempered glass.
- Selective crystal coating absorber coating.
- Attractive bronze extruded aluminum frame.
- SRCC certified and listed.
- 10-year warranty.



SolarCon™ Storage Tank

- 50, 80 & 119 gallon tanks with lower heat exchanger coil and electrical element for backup heating.
- 4,500 watt, UL listed backup element with aquastat.
- 80 & 119 gallon tanks with lower heat exchanger coil and upper heat exchanger coil for boiler backup heating.
- Durable porcelain enamel lining, with protective cobalt.
- Heavy gauge powdered coated steel outside jacket.
- Dual heavy-duty anode rods protection.
- Thick 2" non CFC foam insulation.
- 6-year warranty.



SolarFlex™ Insulated Flexible Stainless Steel Piping

- 1/2", 3/4" and 1" sizes in continuous coils.
- High temperature EPDM insulation UV resistant.
- Heavy durable UV resistant film outside jacket.
- Sensor wire between flow and return pipes.
- 6-year warranty.



iSolar™ Differential Temperature Controller and Solar Station

- LCD user friendly graphic display.
- Variable pump speed control.
- Collector overheat protection.
- Storage tank cooling.
- kWh energy measurement.
- Adjustable delta T function.
- Shut off valves with built-in flow checks.
- Fill and purge plus safety valves.
- Flow meter and flow adjustment.
- Temperature and pressure gages.
- Three speed pump, UL listed.
- 4-year warranty with authorized installer.



SOLAR WATER HEATING SYSTEMS

www.caleffi.us

Caleffi Solar offers several complete, integrated Solar Water Heating Systems that makes the most of the sun's abundant energy. The systems are engineered of highly reliable components that work together to ensure superior system performance. As an added benefit, having all the components from one manufacturer provides the advantage and convenience of reducing system planning and installation time. Caleffi's Solar Water Heating Systems can be installed quickly, with "plug and flow" components that are ready to screw together, without lighting a torch for soldering. All mounts, fittings, connectors and pre-mix glycol included. With their simple, reliable, environmentally friendly technology, the systems are suitable for all types of I buildings and geographic areas. The first complete Solar Water Heater in a Box.

Caleffi North America Inc. - Milwaukee, WI - Tel 414.238.2360 - sales@caleffi.com

CALEFFI SOLAR SOLUTIONS

CALEFFI
Hydronic Solutions