

SUBMITTAL DATA

horizontal steam/hot water unit heaters top and bottom connection, Model HSB

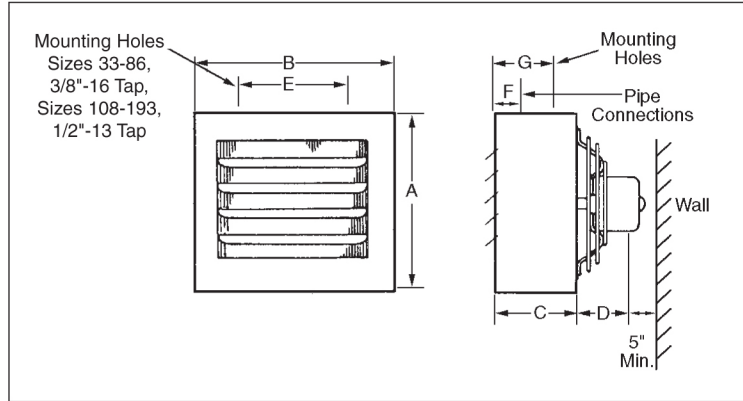

Mounting Holes
Sizes 33-86,
3/8"-16 Tap,
Sizes 108-193,
1/2"-13 Tap

Mounting Holes
Pipe Connections
Wall
5" Min.

Table 1.1 - Dimensions ①②

| Model Number | A | B | C | D | | E | F | G | H | Female Connections NPT | Fan Diameter | Approx. Shipping Wt. lb. |
|--------------|---------|--------|--------|----------------|-----------------|--------|-------|-------|---|------------------------|--------------|--------------------------|
| | | | | 115 Std. Motor | 115V Exp. Motor | | | | | | | |
| HSB-18 | 12-3/8 | 13 | 6 | 5 | 12 | - | 3 | - | - | 3/4 | 9 | 16 |
| HSB-24 | 12-3/8 | 13 | 6 | 6-1/2 | 12 | - | 3 | - | - | 3/4 | 9 | 20 |
| HSB-33 | 16-3/8 | 17-1/2 | 8-3/4 | 6-1/2 | 12-1/4 | 11 | 3-5/8 | 6 | - | 1-1/4 | 12 | 34 |
| HSB-47 | 16-3/8 | 17-1/2 | 8-3/4 | 8 | 12-1/4 | 11 | 3-5/8 | 6 | - | 1-1/4 | 12 | 36 |
| HSB-63 | 20-7/16 | 21-1/2 | 8-3/4 | 8 | 12-3/4 | 15 | 3-5/8 | 6 | - | 1-1/4 | 14 | 48 |
| HSB-86 | 20-7/16 | 21-1/2 | 8-3/4 | 9 | 12-3/4 | 15 | 3-5/8 | 6 | - | 1-1/4 | 14 | 52 |
| HSB-108 | 24-7/16 | 25-1/2 | 9-1/2 | 8 | 11-1/2 | 18 | 3-3/4 | 6-3/8 | - | 1-1/4 | 18 | 74 |
| HSB-121 | 24-7/16 | 25-1/2 | 9-1/2 | 7-1/2 | 11 | 18 | 3-3/4 | 6-3/8 | - | 1-1/4 | 18 | 76 |
| HSB-165 | 30-1/2 | 30-1/2 | 9-1/4 | 9-1/2 | 14 | 21-1/4 | 3-3/4 | 6-3/8 | - | 1-1/4 | 22 | 92 |
| HSB-193 | 30-1/2 | 30-1/2 | 9-1/4 | 9-1/2 | 14 | 21-1/4 | 3-3/4 | 6-3/8 | - | 1-1/4 | 22 | 98 |
| HSB-258 | 38-1/2 | 38-1/2 | 12-1/2 | 10-1/2 | 14 | 18-1/2 | 3-5/8 | 7-7/8 | - | 1-1/4 | 22 | 162 |
| HSB-290 | 38-1/2 | 38-1/2 | 12-1/2 | 10-1/2 | 14 | 18-1/2 | 3-5/8 | 7-7/8 | - | 1-1/4 | 24 | 168 |
| HSB-340 | 38-1/2 | 44-1/2 | 12-1/2 | 10-1/2 | 14 | 18-1/2 | 3-5/8 | 7-7/8 | - | 1-1/4 | 24 | 176 |

① All dimensions in inches.

② Dimensions shown are for Standard and Low Outlet Temperature models.

Table 1.2 - Specifications

| Model No. | Core Type | | Copper Tube Size (Inches) | Copper Tube Wall Thickness (Inches) |
|-----------|-------------------|-------------------|---------------------------|-------------------------------------|
| | Single Serpentine | Double Serpentine | | |
| HSB-18 | X | - | 5/8 OD | 0.028 |
| HSB-24 | X | - | 5/8 OD | 0.028 |
| HSB-33 | X | - | 1 OD | 0.030 |
| HSB-47 | X | - | 1 OD | 0.030 |
| HSB-63 | X | - | 1 OD | 0.030 |
| HSB-86 | X | - | 1 OD | 0.030 |
| HSB-108 | X | - | 1 OD | 0.030 |
| HSB-121 | X | - | 1 OD | 0.030 |
| HSB-165 | X | - | 1 OD | 0.030 |
| HSB-193 | - | X | 1 OD | 0.030 |
| HSB-258 | - | X | 1 OD | 0.030 |
| HSB-290 | - | X | 1 OD | 0.030 |
| HSB-340 | - | X | 1 OD | 0.030 |

Junction Box

All units include an electrical junction box either integral to the motor or attached to the unit casing. Explosion proof units include an explosion proof junction box attached to the motor.

1-451.13 SUBMITTAL DATA

Table 2.1
Motor Data ①

| Model Number | Motor HP ② | Motor Type, Voltage and Power Code | | | | | | | |
|--------------|------------|-------------------------------------|----------|----------|--------------|-----------|----------|------------------------------------|--------------|
| | | Totally Enclosed w/Thermal Overload | | | | | | Explosion Proof w/Thermal Overload | |
| | | 115/60/1 | 200/60/1 | 230/60/1 | 200-208/60/3 | 230/460/3 | 575/60/3 | 115/60/1 | 230/460/60/3 |
| | | 01 | N/A | 02 | 04 | 05 | 10 | 06 | 09 |
| | | Amps | Amps | Amps | Amps | Amps | Amps | Amps | Amps |
| HSB/HC-18 | 1/60 | 0.8 | ③ | 0.44 | ③ | ③ | ③ | 3.1 | - |
| HSB/HC-24 | 1/25 | 1.6 | ③ | 0.44 | ③ | ③ | ③ | 3.1 | - |
| HSB/HC-33 | 1/25 | 1.6 | ③ | 1 | ③ | ③ | ③ | 3.1 | - |
| HSB/HC-47 | 1/12 | 2.2 | ③ | 1 | ③ | ③ | ③ | 3.1 | - |
| HSB/HC-63 | 1/12 | 2.2 | ③ | 1 | ③ | ③ | ③ | 3.1 | - |
| HSB/HC-86 | 1/8 | 2.3 | ③ | 1 | ③ | ③ | ③ | 3.1 | - |
| HSB/HC-108 | 1/8 | 2.3 | ③ | 1 | ③ | ③ | ③ | 3.1 | - |
| HSB/HC-121 | 1/5 | 2.8 | ③ | 1.5 | ③ | ③ | ③ | 4.1 | 1.5/0.75 |
| HSB/HC-165 | 1/3 | 5.4 | ③ | 2.23 | ③ | ③ | ③ | 6.1 | 1.5/0.75 |
| HSB/HC-193 | 1/3 | 5.4 | ③ | 2.23 | ③ | ③ | ③ | 6.1 | 1.5/0.75 |
| HSB/HC-258 | 1/2 | 7.5 | ③ | 3.5 | ③ | ③ | ③ | 5.8 | 2.0/1.0 |
| HSB/HC-290 | 1/2 | 7.5 | ③ | 3.5 | ③ | ③ | ③ | 5.8 | 2.0/1.0 |
| HSB/HC-340 | 1/2 | 7.5 | ③ | 3.5 | ③ | ③ | ③ | 5.8 | 2.0/1.0 |

① Ratings shown are for Standard and Low Outlet Temperature Models.

② Motor HP listed for power code 01.

③ For supply voltages of 200V/60Hz/1ph and all non-explosion proof 3 phase voltages of 200, 230, 460 and 575, Model Numbers indicated with Note ③, require that a 115V/60Hz/1 phase Power Code 01 unit heater be used with a shipped loose accessory transformer. See Table 2.2 for Transformer Sizes.

Figure 2.1
Field Installed Transformer Accessory



Table 2.2 - Step-Down Transformer Accessory Selection

| | 200V/60Hz/1 or 3 phase | 230/460V/ 60Hz/3 phase | 575V/60Hz/ 3 phase |
|---------------------|---------------------------|---------------------------|-----------------------|
| Model Number | kVA | kVA | kVA |
| HSB 18-63 | 0.50 | 0.25 | 0.25 |
| HSB 86-121 | | 0.50 | 0.50 |
| HSB165-193 | 1.00 | 0.75 | 0.75 |
| HSB258-340 | | 1.00 | 1.00 |

| kVA Size | Ship Wt. (Lb.) |
|----------|----------------|
| 0.25 | 7 |
| 0.50 | 13 |
| 0.75 | 15 |
| 1.00 | 19 |