

**INSTALLATION AND SERVICE MANUAL
HOT DAWG H₂O® - Low Profile Hot Water Unit Heater
Model HDD**



! WARNING

Improper installation, adjustment, alteration, service or maintenance can cause property damage, injury or death. Read the installation, operating and maintenance instructions thoroughly before installing or servicing this equipment.

IMPORTANT

The use of this manual is specifically intended for a qualified installation and service agency. A qualified installation and service agency must perform all installation and service of these appliances.

General Information

Installation and service instructions in this manual are applicable to model HDD, low profile hot water unit heaters, which should be installed in their proper applications for their most effective function as heating units.

The water coils are warranted for operation at water pressures up to 150 psi and temperatures up to 200 °F.

Motors are designed for continuous duty. They can operate in a maximum ambient temperature of 104 °F (40 °C).

The unit heaters are listed by ETL as certified. Units not approved for use in potable water systems.

Table of Contents

General Information.....	1
Inspection on Arrival.....	1
Special Precautions.....	2
SI (Metric) Conversion Factors.....	2
Installation	
Unit Location.....	3
Unit Mounting.....	4-5
Hot Water Piping.....	6
Electrical Connections.....	6
Start-Up Procedure	
Prior to Operation.....	7
Initial Start-Up.....	7
Typical Sequence of Operation.....	7
Troubleshooting.....	7
Blower Removal Instructions.....	8-10
Unit Data	
Dimensions.....	11
Electrical Data.....	11
Mechanical Data.....	11
Performance Data.....	12
Maintenance/Replacement Parts.....	13

Inspection upon Arrival

1. Inspect unit upon arrival. In case of damage, report immediately to transportation company and your local factory sales representative.
2. Check rating plate on unit to verify that the power supply meets available electric power at the point of installation.
3. Inspect unit received for conformance with description of product ordered (including specifications where applicable).

Note: Modine Manufacturing Company has a continuous product improvement program, and therefore reserves the right to change design and specifications without notice.

SPECIAL PRECAUTIONS

THE INSTALLATION AND MAINTENANCE INSTRUCTIONS IN THIS MANUAL MUST BE FOLLOWED TO PROVIDE SAFE, EFFICIENT, AND TROUBLE-FREE OPERATION. IN ADDITION, PARTICULAR CARE MUST BE EXERCISED REGARDING THE SPECIAL PRECAUTIONS LISTED BELOW. FAILURE TO PROPERLY ADDRESS THESE CRITICAL AREAS COULD RESULT IN PROPERTY DAMAGE OR LOSS, PERSONAL INJURY, OR DEATH. THESE INSTRUCTIONS ARE SUBJECT TO ANY MORE RESTRICTIVE LOCAL OR NATIONAL CODES.

HAZARD INTENSITY LEVELS

- DANGER:** Indicates an imminently hazardous situation which, if not avoided, WILL result in death or serious injury.
- WARNING:** Indicates a potentially hazardous situation which, if not avoided, COULD result in death or serious injury.
- CAUTION:** Indicates a potentially hazardous situation which, if not avoided, MAY result in minor or moderate injury.
- IMPORTANT:** Indicates a situation which, if not avoided, MAY result in a potential safety concern.

DANGER

Units must not be installed where they may be exposed to potentially explosive or flammable atmosphere.

WARNING

- Disconnect power supply before making wiring connections to prevent electrical shock and equipment damage.
- All appliances must be wired strictly in accordance with the wiring diagram furnished with the appliance. Any wiring different from the wiring diagram could result in a hazard to persons and property.
- Any original factory wiring that requires replacement must be replaced with wiring material having a temperature rating of at least 105 °C.
- Ensure that the supply voltage to the appliance, as indicated on the serial plate, is not 5% greater than the rated voltage.
- When servicing or repairing of this equipment, use only factory-approved service replacement parts. A complete replacement parts list may be obtained by contacting Modine Manufacturing Company. Refer to the rating plate on the unit for complete model and serial number and Company address. Any substitution of parts or controls not approved by the factory will be at the owner's risk.

CAUTION

- All literature shipped with this unit should be kept for future use for servicing or service diagnostics. Leave manual with the owner. Do not discard any literature shipped with this unit.
- Consult piping and electrical instructions in this manual before final installation.

CAUTION

- Units are designed for use in heating applications with ambient temperatures between 40 °F and 100 °F. Heaters should not be used in applications where the heated space temperature is below 40 °F unless a glycol anti-freeze solution has been added.
- Units not approved for use in potable water systems.
- Do not install units below 7' measured from the bottom of the unit to the floor in commercial applications (unless unit is properly guarded to provide user protection from moving parts) and 5' measured from the bottom of the unit to the floor in residential applications.
- Do not reuse any mechanical or electrical components which have been wet. Replace defective components.
- Do not operate the unit with steam. The coil is not designed for steam condensate removal which can damage the unit.
- Ensure the supply voltage to the appliance, as indicated on the serial plate, is not 5% less than the rated voltage.

IMPORTANT

- Start-up and adjustment procedures should be performed by a qualified service agency.
- Be sure no obstructions block air intake and discharge of unit heaters. Do not attach ductwork or air filters to this unit heater. Maintain a minimum of 6" clearance to inlet openings.
- When mounting the unit to the joists, do not compress the vibration isolators by over tightening the lag bolt screws into the joist. Doing so will greatly reduce the ability of the isolator to dampen vibration.
- No water-flow can cause a freeze condition resulting in damage to the coil.
- Never leave the unit filled with water in a building without heat unless antifreeze has been added.
- To check most of the Possible Remedies in the troubleshooting guide listed in Table 7.1, refer to the applicable sections of the manual.

Table 2.1 – SI (Metric) Conversion Factors

To Convert	Multiply By	To Obtain	To Convert	Multiply By	To Obtain
W.C.	0.249	kPa	feet	0.305	m
°F	(°F-32) x 5/9	°C	Gal/hr	0.00379	m³/hr
BTU	1.06	kJ	Gal/hr	3.79	l/hr
BTU/ft³	37.3	kJ/m³	gallons	3.79	l
BTU/hr	0.000293	kW	Horsepower	746	W
CFH (ft³/hr)	0.000472	m³/min	inches	25.4	mm
CFH (ft³/hr)	0.00000787	m³/s	pound	0.454	kg
CFM (ft³/min)	0.0283	m³/min	psig	6.89	kPa
CFM (ft³/min)	0.000472	m³/s	psig	27.7	W.C.

INSTALLATION – UNIT LOCATION

! DANGER

Units must not be installed where they may be exposed to potentially explosive or flammable atmosphere.

! CAUTION

1. All literature shipped with this unit should be kept for future use for servicing or service diagnostics. Leave manual with the owner. Do not discard any literature shipped with this unit.
2. Consult piping and electrical instructions in this manual before final installation.
3. Units are designed for use in heating applications with ambient temperatures between 40 °F and 100 °F. Heaters should not be used in applications where the heated space temperature is below 40 °F unless a glycol anti-freeze solution has been added.
4. Units not approved for use in potable water systems.

IMPORTANT

1. Start-up and adjustment procedures should be performed by a qualified service agency.
2. Be sure no obstructions block air intake and discharge of unit heaters. Do not attach ductwork or air filters to this unit heater. Maintain the minimum clearance to inlet openings shown in figure 11.1.
1. Units should not be installed in atmospheres where corrosive fumes or sprays are present.
2. When locating the heater, consider general space and heating requirements and availability of hot water and electrical supply.
3. Be sure the structural support at the unit location site is adequate to support the unit's weight.
4. Determine mounting orientation of the unit heater. Figure 3.1 shows three typical orientations. Additional details can be seen in Figure 5.2.
5. Be sure no obstructions block air intake and discharge of unit heaters. Do not attach ductwork or air filters to this unit heater. Maintain the minimum clearance to inlet openings shown in figure 11.1. Failure to do so will result in poor unit performance.
6. Unit heaters installed in a building exposed to a prevailing wind should be located to direct a major volume of heated air along the windward wall.
7. Vertical delivery unit heaters should generally be located in the central area of the space to be heated. Place horizontal delivery units along the walls of the same building where heat loss is usually greatest.
8. Locate units so they do not blow directly at occupants.
9. Locate units so their air streams blanket exposed walls.

Reversing Electrical/Piping Connection Access

Units feature electrical access on the left and piping connections on the right as standard (when looking at the unit). If the installation requires the access to be reversed,

the unit can be flipped 180° from the way it was received from the factory. By doing so, the sides become opposite but the front and back remain in the same relative position. The bottom panel now becomes the top panel and vice-versa. Be sure to remove the spring loaded deflector blades, turn them over, replace, and adjust so they are open and in a position to direct the heated air down to the floor. Note that the labels on the front of the unit will be upside down. New stickers can be purchased from Modine.

Figure 3.1 – Model HHD Mounting Orientations

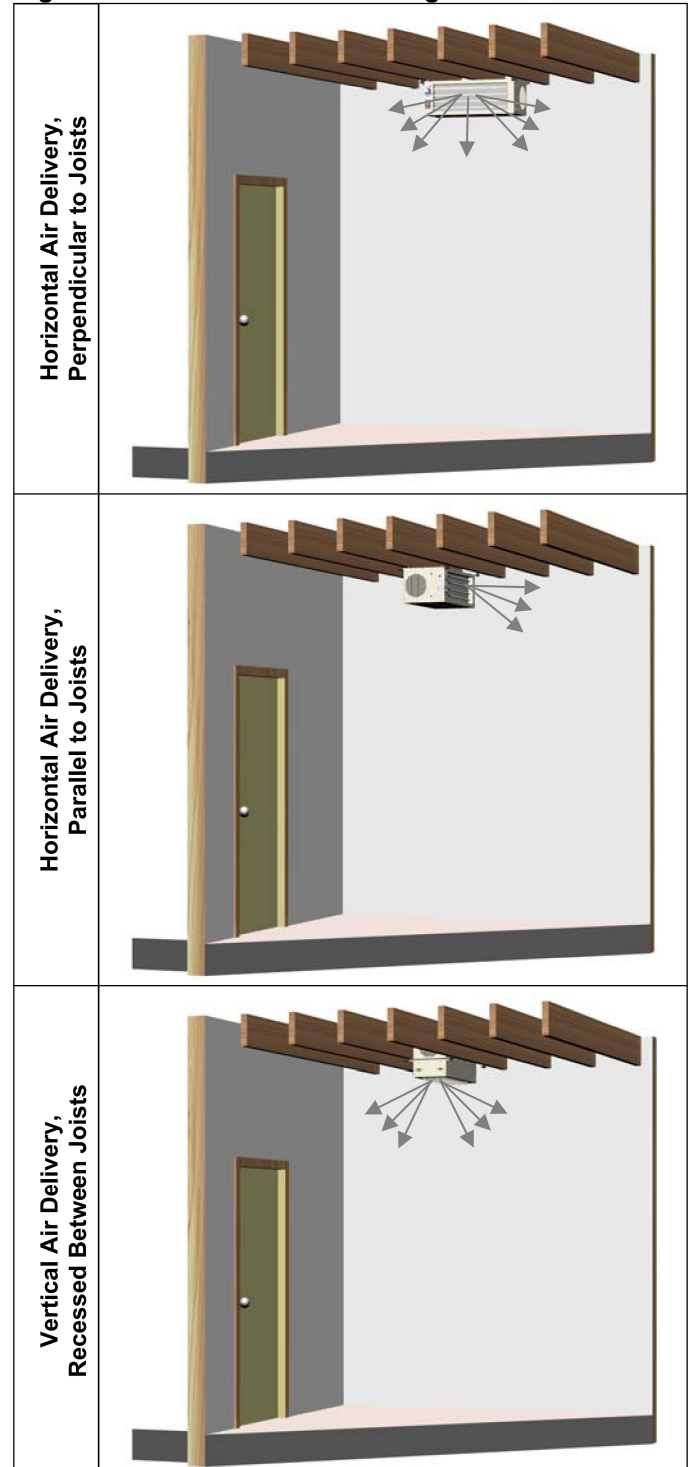

INSTALLATION – UNIT MOUNTING

CAUTION

Do not install units below 7' measured from the bottom of the unit to the floor in commercial applications (unless unit is properly guarded to provide user protection from moving parts) and 5' measured from the bottom of the unit to the floor in residential applications.

IMPORTANT

When mounting the unit to the joists, do not compress the vibration isolators by over tightening the lag bolt screws into the joist. Doing so will greatly reduce the ability of the isolator to dampen vibration.

1. Be sure the means of suspension is adequate to support the weight of the unit (see Table 8.1 for unit weights).
2. Before lifting the heater for suspension, based on the mounting orientation selected (refer to Figure 3.1), the mounting brackets must be installed on the unit as follows:

For Horizontal Air Delivery Orientations:

- a) Position the brackets on the top of the unit as shown in Figure 4.1.

For Vertical Air Delivery Orientations:

- a) Position the brackets on the side of the unit as shown in Figure 5.1. Note the following:
 - For 10" or 12" deep joists, the bracket can be oriented as shown in the top picture.
 - For 12" deep joists, the bracket can be oriented as shown in the bottom picture for additional headroom. Refer also to Figure 5.2.
 - If required, louver blades can be flipped to change the direction of airflow control. To do so, remove the spring loaded deflector blades, turn them over, replace, and adjust so they are open and in a position to direct the heated air.

For All Units:

- b) Secure the brackets to the unit with the 3/8"-16 x 1" Hex Bolts and 3/8" Lock Washers included with the bracket kit. The bolts thread into the retaining nuts that are located in the top of the unit casing.
- c) Repeat for the bracket on the left side of the unit (not pictured).
- d) Install the vibration isolators that were supplied with the unit (see Figure 4.1) by inserting the smaller diameter pieces through the 3/4" diameter holes from the top side of the bracket. The larger diameter pieces are fitted from the bottom side. The outer diameter of the top mounted pieces will friction fit into the inside diameter of the bottom pieces.

3. With the brackets installed on the unit, the unit can be installed to the ceiling joists or trusses as follows (refer to Figure 5.2):
 - The bracket mounting hole locations accommodate joists on 16" centerlines.
 - Use (4) 1/4" lag bolt screws (supplied by others) that are at least 3" long. The (4) 1-1/2" x 1/4" Fender Washers (supplied by Modine) must be placed between the lag bolt screw and bottom vibration isolation piece
 - Install the lag bolt screws until the top of the isolator just touches the bottom of the joist. Do not compress the isolator by over tightening the lag bolt screw. Doing so will greatly reduce the ability of the isolator to dampen vibration.

Figure 4.1
Bracket Installation for Horizontal Air Delivery

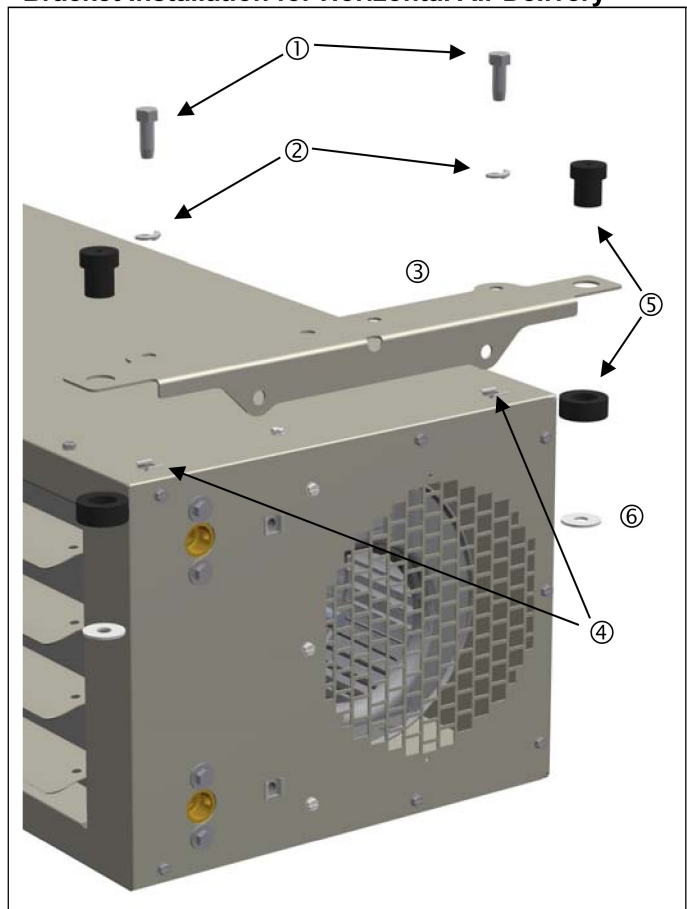

Item	Qty (total for unit) - Description
①	Qty (4) – Hex Bolts, 3/8"-16 x1"
②	Qty (4) – 3/8" Lock Washers
③	Qty (2) – Mounting Brackets
④	Qty (4) – Retainer Nuts , 3/8"-16
⑤	Qty (4) – Two-Piece Vibration Isolators
⑥	Qty (4) – 1-1/2" x 1/4" Fender Washers (used when the unit is installed to the joists)

Note: Figure 4.1 shows the unit with standard right hand piping connections. See page 3 for instructions on reversing the piping access side.

START UP PROCEDURE / TROUBLESHOOTING

Figure 5.1
Bracket Installation for Vertical Air Delivery

Bracket Orientation for 10" or 12" Deep Joists

Bracket Orientation for 12" Deep Joists

Item	Qty (total for unit) - Description
①	Qty (4) – Hex Bolts, 3/8"-16 x1"
②	Qty (4) – 3/8" Lock Washers
③	Qty (2) – Mounting Brackets
④	Qty (4) – Retainer Nuts , 3/8"-16
⑤	Qty (4) – Two-Piece Vibration Isolators
⑥	Qty (4) – 1-1/2" x 1/4" Fender Washers (used when the unit is installed to the joists)

Figure 5.2
Model HHD Mounting Orientations

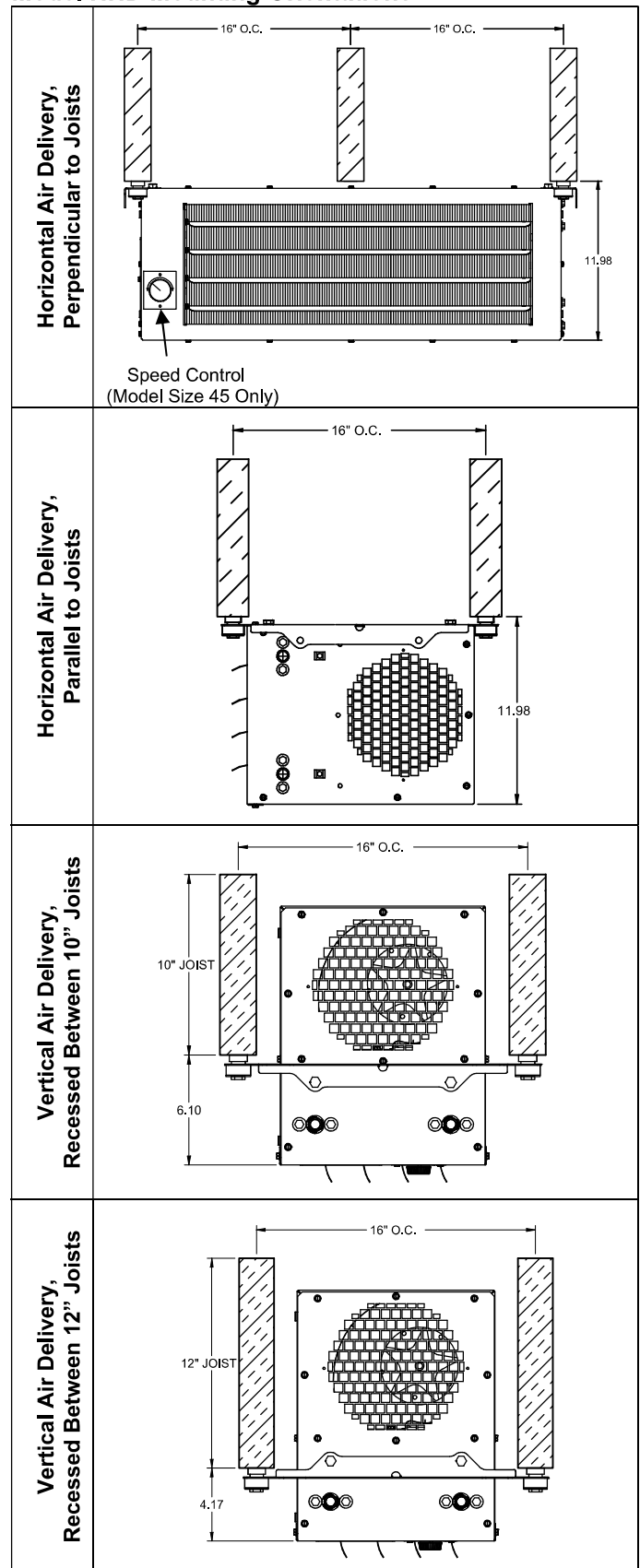

INSTALLATION – HOT WATER PIPING / ELECTRICAL CONNECTIONS

HOT WATER PIPING

⚠ CAUTION

1. Units are designed for use in heating applications with ambient temperatures between 40 °F and 100 °F. Heaters should not be used in applications where the heated space temperature is below 40 °F unless a glycol anti-freeze solution has been added.
2. Units not approved for use in potable water systems.
3. Do not reuse any mechanical or electrical components which have been wet. Replace defective components.
4. Do not operate the unit with steam. The coil is not designed for steam condensate removal which can damage the unit.

IMPORTANT

1. No water-flow can cause a freeze condition resulting in damage to the coil.
2. Never leave the unit filled with water in a building without heat unless a glycol solution has been added.
3. Do not operate the units with steam. The coil is not designed for steam condensate removal which can damage the unit.
4. Supply and return lines should be adequately sized to handle heating requirements under maximum load.
5. Piping connections are ½ "NPT (see Figure 6.1).
6. Install unions and shut-off valves in lines to and from the unit to allow maintenance or replacement of unit without shutting down and draining entire system.
7. Install a return line circuit setter to regulate water flow.
8. Include an air vent at the high point of the piping to allow removal of entrained air if required.
9. Include a drain valve (hose bib) at the low end of the piping to allow removal of water from the coil if required.
10. It is advisable to use a pipe line strainer before the coil.
11. Provide adequate pipe hangers, supports, or anchors to secure the piping system independently of the coil.
12. Install piping to provide for expansion and contraction normally encountered with temperature changes.
13. Hot water pipes should be insulated to reduce heat loss.

Figure 6.1 – Unit Electrical and Piping Access Locations

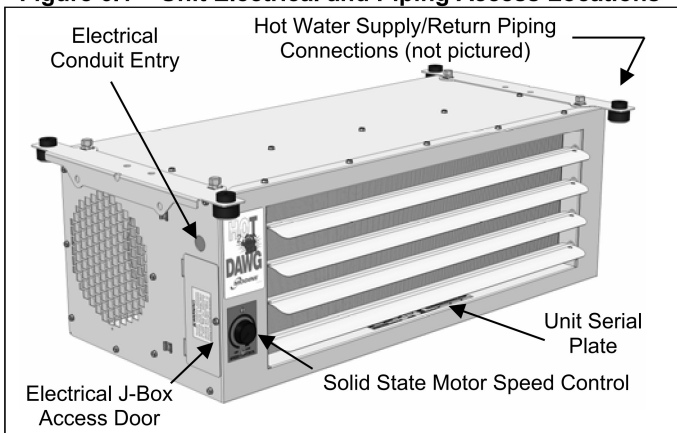

Note: Standard piping/electrical access side orientation shown.

ELECTRICAL CONNECTIONS

⚠ WARNING

1. Disconnect power supply before making wiring connections to prevent electrical shock and equipment damage.
2. All appliances must be wired strictly in accordance with the wiring diagram furnished with the appliance. Any wiring different from the wiring diagram could result in a hazard to persons and property.
3. Any original factory wiring that requires replacement must be replaced with wiring material having a temperature rating of at least 105 °C.
4. Ensure that the supply voltage to the appliance, as indicated on the serial plate, is not 5% greater than rated voltage.

⚠ CAUTION

Ensure the supply voltage to the appliance, as indicated on the serial plate, is not 5% less than the rated voltage.

1. Installation of wiring must conform with local building codes, or in the absence of local codes, with the National Electric Code ANSI/NFPA 70 - Latest Edition. Unit must be electrically grounded in conformance to this code. In Canada, wiring must comply with CSA C22.1, Part 1, Electrical Code.
2. Electric wiring must be sized to carry the full load amp draw of the motor and any controls that are used with the unit heater.
3. The power supply to the unit must be protected with a fused or circuit breaker switch, sized based on motor current rating shown on the unit serial plate, and applicable National Electric Code procedures.
4. All units are provided with an electrical junction box (Figure 6.1). Make wiring connections from 115V/60Hz/1ph building service to control box as shown on wiring diagram furnished with the unit (Figure 6.2).
5. Any damage to or failure of Modine units caused by incorrect wiring of the units is not covered by warranty.
6. The power supply must be within +/- 5 percent of the voltage rating. If not, advise the utility company.

Figure 6.2 – Unit Electrical Wiring Diagram

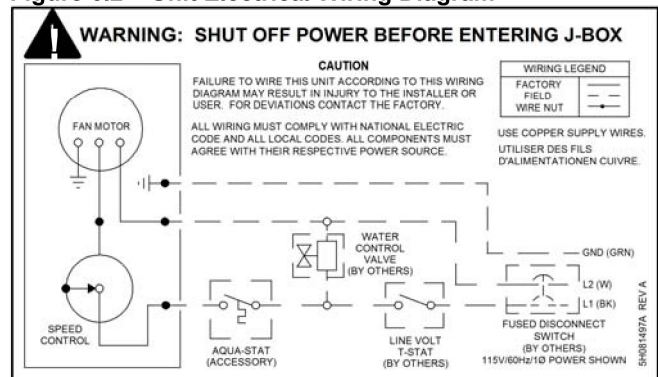

INSTALLATION – HOT WATER PIPING / ELECTRICAL CONNECTIONS

START-UP PROCEDURE

IMPORTANT

1. Start-up and adjustment procedures should be performed by a qualified service agency.
2. No water-flow can cause a freeze condition resulting in damage to the coil.
3. Never leave the unit filled with water in a building without heat unless a glycol solution has been added.

PRIOR TO OPERATION

1. Check that all the electrical connections are tight.
2. Check that the unit has the correct main power supply wired to the unit and is within +/- 5% of the voltage shown on the unit serial plate.
3. Check that the power supply to the unit is protected with a properly sized fused or circuit breaker switch.
4. Check that the unit has no visible damage and that all the components are secure.
5. Check that all field electrical and mechanical work has been performed according to all applicable Federal, State, and Local codes.
6. Check that the system has been correctly flushed.
7. Check for any water leaks.
8. Check rigidity of unit mounting. Tighten all fasteners if necessary.
9. Inspect piping, strainers, fittings, etc.

INITIAL START-UP

1. Set thermostat to lowest position.
2. Turn on power supply to unit.
3. Open field installed supply and return shut-off valves.
4. Raise thermostat setting to desired position.
5. Check for correct fan operation, no excessive noise or vibrations.
6. Confirm that air is blowing out of the discharge opening.
7. Adjust louvers for desired heat distribution.
8. Check water flow rates and compare to design.
9. To insure proper sequence of operation, cycle unit on and off a few times by raising and lowering thermostat setting.

TYPICAL SEQUENCE OF OPERATION

Fan Operation

Fan operation can be either intermittent on a call for heat from a room stat or continuous. An aquastat accessory can be strapped to the return piping to prevent fan operation when heat is not being supplied to the unit heater.

Models feature a solid state speed control that allows infinite speed control between high speed and low speed and also provides an "OFF" setting for the unit.

Intermittent Hot Coil

A room thermostat controls a valve which opens to allow hot water to supply the unit and closes to shut off the supply when the thermostat is satisfied.

Continuous Hot Coil

A valve opens to allow continuous hot water flow to the coil whenever the system is energized. Continuous hot coil operation may help prevent coil freeze-ups in cold weather, however, a proper glycol mix is also recommended.

Table 7.1 – Troubleshooting

TROUBLE	POSSIBLE CAUSE	POSSIBLE REMEDY
Unit Not Operating – Power On	<ol style="list-style-type: none"> 1. Speed control in "OFF" position. 2. Tripped circuit breaker(s). 3. Loose supply power wiring. 	<ol style="list-style-type: none"> 1. Turn speed control to any position but "OFF". 2. Reset the tripped circuit breaker(s). 3. With power OFF, inspect wiring connections.
Unit Operating – No Heat	<ol style="list-style-type: none"> 1. Thermostat not calling for heat. 2. Loose wiring. 3. Faulty control valve. 	<ol style="list-style-type: none"> 1. Adjust setting on room thermostat. 2. Inspect wiring at thermostat and valve. 3. Test and replace valve if faulty.
Unit Fan Not Operating	<ol style="list-style-type: none"> 1. Motor internal overload protection tripped. 2. Motor failure. 3. Speed control failure (size 45 only) 4. Fan not required. 5. No power to the fan. 	<ol style="list-style-type: none"> 1. Let motor cool to allow overload protection to automatically reset 2. Replace motor. 3. Replace speed control. 4. Check that thermostat is set to call for heat. 5. Check wiring connections and panel fuse.

START UP PROCEDURE / TROUBLESHOOTING

Figure 8.1

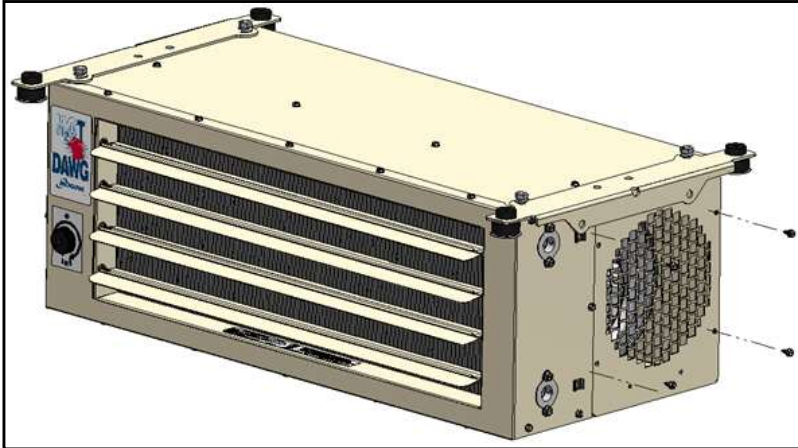

- 1) Remove sheet metal screws, Size #10 X 1/2", Qty-4 From the Access Panel as shown in Fig 8.1

Figure 8.2

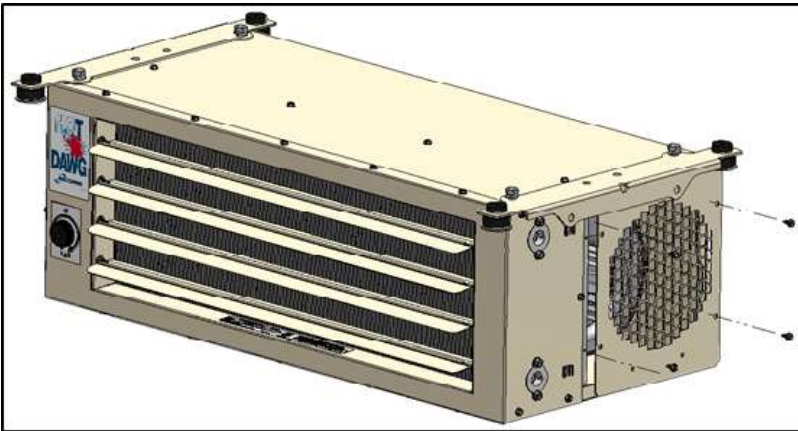

- 2) Remove the tilted Access Panel by moving it towards back by 1" as shown in Fig 8.2

START UP PROCEDURE / TROUBLESHOOTING

Figure 9.1

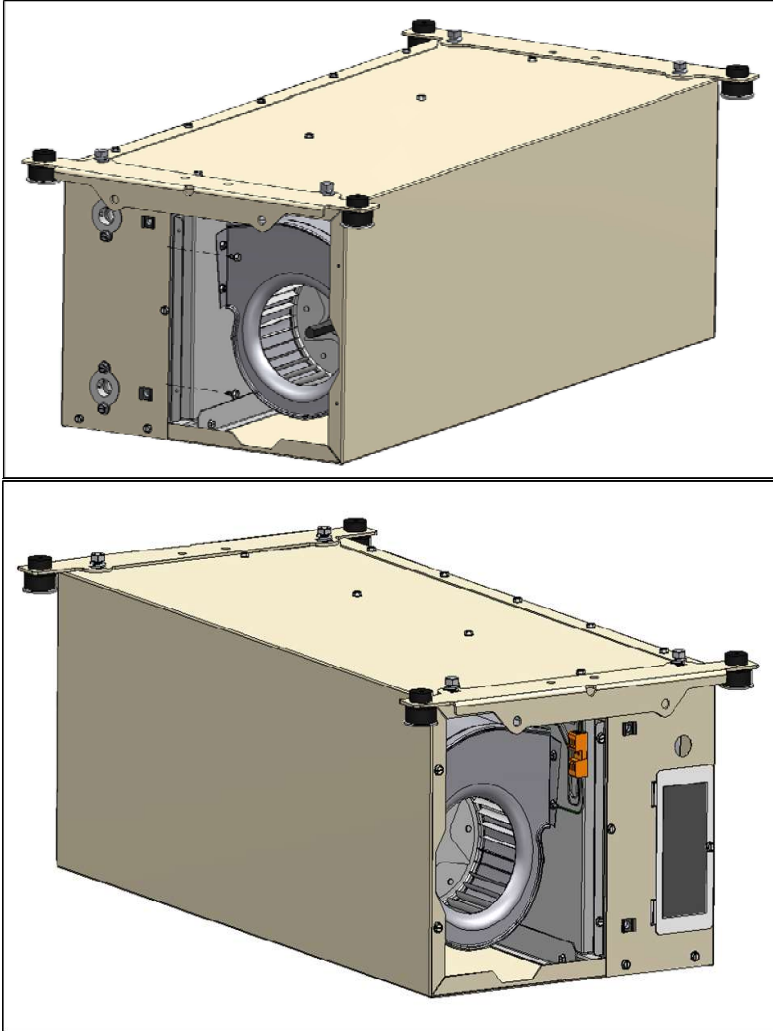

- 3) Remove the 2 inside screws, Size #10 X 1/2", Qty-2 from Fan Board Assembly as shown in Fig 9.1
- 4) Steps 1 to 3 needs to be repeated on the Control Panel Side.

Figure 9.2

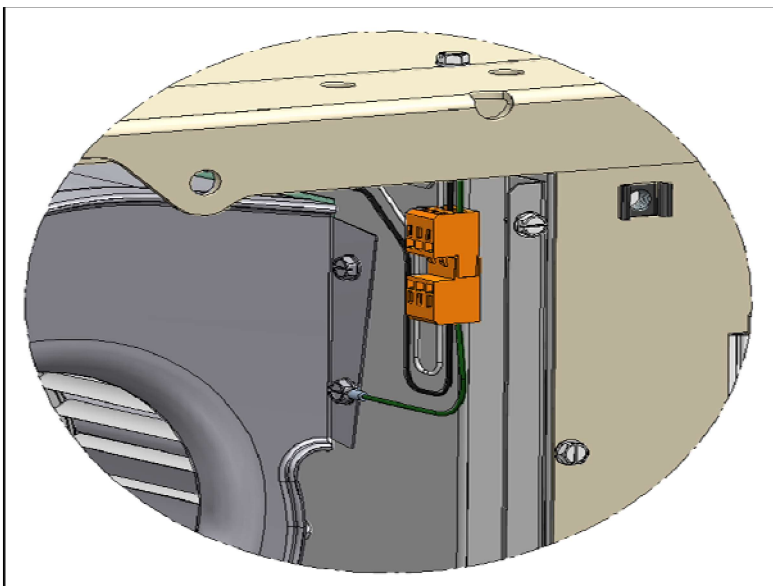

- 5) Remove Plug to separate Motor & Ground wire from the Control Panel as shown in Fig 9.2

START UP PROCEDURE / TROUBLESHOOTING

Figure 10.1

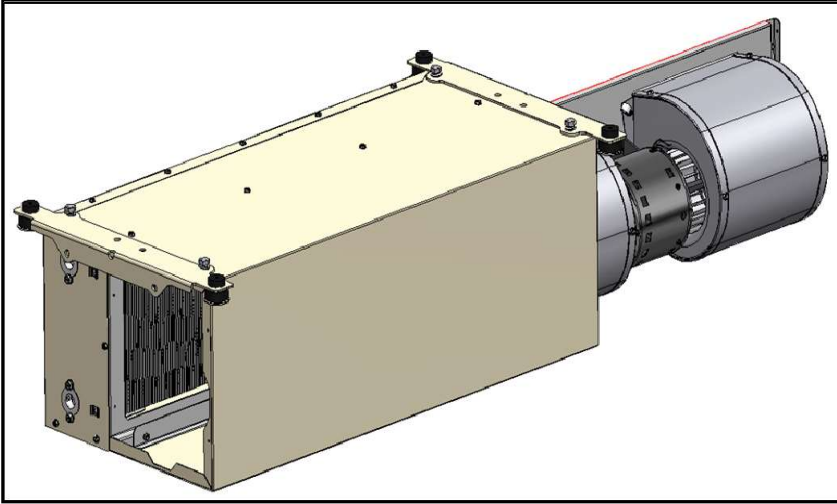

- 6) Now the Fan Board Assembly will slide out from either side of the casing as shown in fig 10.1. **Caution:** - Weight of Fan Board Assembly is approximately 27 lbs.

Figure 11.1 – Dimensions (inches)

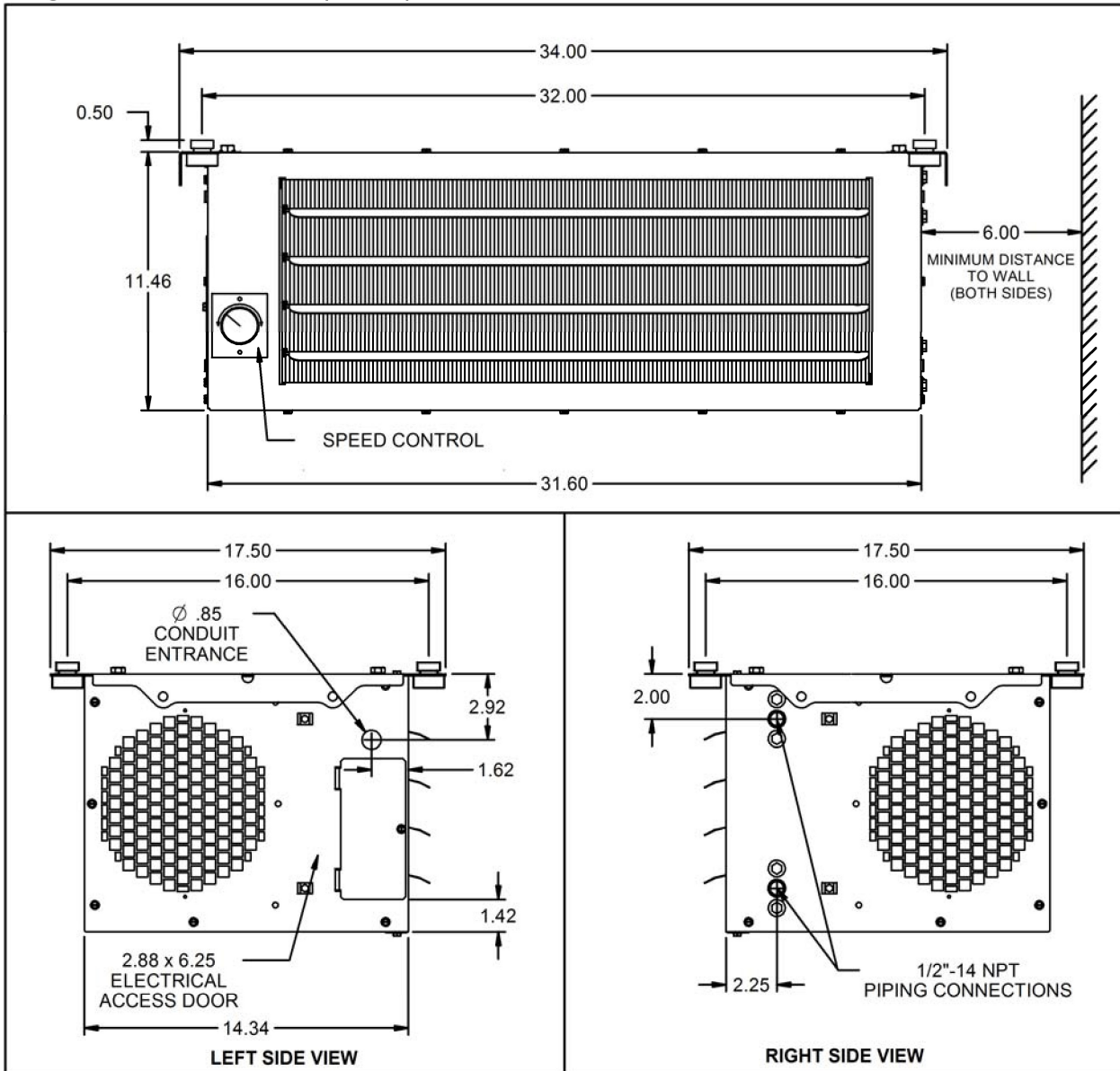

Note: Mounting point spacing on brackets based on joist spacing 16" on-center.

Table 8.1 – Unit Mechanical/Electrical Data

Unit Size	30	45
Coil		
High Capacity – 2 Row Face Area, ft ²	1.625	1.625
Standard Coil Connections	½" NPT	½" NPT
Approximate Coil Volume (Gallons)	0.40	0.40
Blowers (Direct Drive)		
(Qty) - Diameter x Width (Inches)	(2) – 5.75 x 7	(2) – 5.75 x 7
High Speed (RPM)	1050	1625
Motor Blower Connection	Direct Drive	Direct Drive
Low Speed (RPM)	725	1090
High CFM	405	710
Low CFM	280	425
Motor		
Motor Type	Permanent Split Cap	Permanent Split Cap
Shaft Arrangement	Double Shaft	Double Shaft
(Qty) - HP	(1) – 1/20	(1) – 0.40
Voltage	115V/1ph/60Hz	115V/1ph/60Hz
Shipping Weight – lbs. (approximate)	70	73

PERFORMANCE DATA

Table 9.1 – Performance Data ①②

Model Size	Airflow CFM	GPM	Entering Water Temperature (60°F Entering Air Temperature)										
			WPD	120°F		140°F		160°F		180°F		200°F	
			(ft. Water)	Btu/Hr	WTD	Btu/Hr	WTD	Btu/Hr	WTD	Btu/Hr	WTD	Btu/Hr	WTD
30	405 (High Speed)	1	0.6	11,900	25	15,800	33	19,800	41	23,700	49	27,700	58
		2	2.2	15,500	16	20,600	22	25,800	27	30,900	32	36,100	38
		3	4.7	17,200	12	22,900	16	28,600	20	34,400	24	40,100	28
		4	7.9	18,200	10	24,200	13	30,300	16	36,300	19	42,400	22
		5	12.0	19,600	8	26,100	11	32,600	14	39,200	16	45,700	19
	280 (Low Speed)	1	0.6	9,100	19	12,200	25	15,200	32	18,300	38	21,300	44
		2	2.2	12,000	13	15,900	17	19,800	21	23,800	25	27,800	29
		3	4.7	13,200	9	17,600	12	22,000	15	26,400	18	30,800	21
		4	7.9	14,000	7	18,600	10	23,300	12	27,900	15	32,600	17
		5	12.0	15,100	6	20,100	8	25,100	10	30,200	13	35,200	15
45	710 (High Speed)	1	0.6	17,200	36	22,900	48	28,600	60	34,400	72	40,100	84
		2	2.2	22,400	23	29,900	31	37,300	39	44,800	47	52,300	55
		3	4.7	24,900	17	33,200	23	41,500	29	49,800	35	58,100	40
		4	7.9	26,400	14	35,100	18	43,900	23	52,700	27	61,500	32
		5	12.0	28,400	12	37,800	16	47,300	20	56,800	24	66,300	28
	425 (Low Speed)	1	0.6	11,900	25	15,900	33	19,900	41	23,900	50	27,900	58
		2	2.2	15,600	16	20,700	22	25,900	27	31,100	33	36,300	38
		3	4.7	17,300	12	23,000	16	28,800	20	34,600	24	40,300	28
		4	7.9	18,300	10	24,400	13	30,500	16	36,600	19	42,700	22
		5	12.0	19,700	8	26,300	11	32,800	14	39,400	16	46,000	19

① For conditions other than shown above, please refer to the Modine Breeze AccuSpec program for detailed performance data.

② Allowable water temperature range is 100 °F to 200 °F. Allowable indoor air temperature range is 40 °F to 100 °F. If temperatures below freezing are expected, provisions should be made to either drain the unit heater coil or utilize a continually circulating glycol solution.

Useful Formulas:

Air Temperature Rise

The air temperature rise can be calculated by the following formula:

$$\text{Air Temp Rise} = \frac{\text{Btu/Hr}}{1.08 \times \text{CFM}}$$

Example:

What is the Air Temp Rise for a model size 45 unit, operating at high speed, 140 °F entering water, 3 GPM flow rate?

From Table 9.1, the output is 33,200 Btu/Hr. The air temperature rise, per the formula above, is:

$$\text{Air Temp Rise} = \frac{33,200 \text{ Btu/Hr}}{1.08 \times 710 \text{ CFM}} = 43^\circ\text{F}$$

Final Air Temperature

The final discharge air temperature can be calculated by the following formula:

$$\text{Final Air Temperature} = \text{Air Temperature Rise} + \text{Entering Air Temperature}$$

Example:

What is the Final Air Temperature for the previous example?

The air temperature rise was previously calculated to be 43 °F. The final air temperature, per the formula above, is:

$$\text{Final Air Temperature} = 43^\circ\text{F} + 60^\circ\text{F} = 103^\circ\text{F}$$

MAINTENANCE / REPLACEMENT PARTS

MAINTENANCE

! WARNING

When servicing or repairing of this equipment, use only factory-approved service replacement parts. A complete replacement parts list may be obtained by contacting Modine Manufacturing Company. Refer to the rating plate on the unit for complete model and serial number and Company address. Any substitution of parts or controls not approved by the factory will be at the owner's risk.

! CAUTION

Do not reuse any mechanical or electrical controllers which have been wet. Replace defective controller.

IMPORTANT

To check most of the Possible Remedies in the troubleshooting guide listed in Table 7.1, refer to the applicable sections of the manual.

All installation and service of these units must be performed by a qualified installation and service agency.

Before any service, BE SURE TO TURN OFF ALL ELECTRICAL POWER TO THE HEATER. Turn off supply and return shut off valves as required.

At a minimum, before the start of each heating season:

1. With the Disconnect Switch in the "OFF" position, inspect all electrical circuits for loose connections and signs of physical damage.
2. Wipe clean or vacuum the electrical junction box section of all dirt that may affect the unit operation.
3. Check for correct fan operation, no excessive noise or vibrations.
4. Wash down the cabinet using mild detergent and treat any paint damage or rust as necessary.
5. Clean coil of dirt, lint, and dust, which can reduce the unit heating capacity. Use a high pressure air hose to loosen dirt by blowing from side where air leaves coil. Coils subjected to corrosive fumes should be checked and cleaned frequently. Do not use any commercial solvent that could deteriorate the coil and do not use any liquid or steam sprays that could damage electrical components.
6. Provide controlled water treatment; don't use excessive amounts of boiler compounds. Contact your boiler compound supplier for proper usage.
7. Periodic internal flushing of the coils is recommended in areas where water supply is suspected of causing scale. Use an alkaline-chelant solution and introduce it at the main pump of the hydronic system. Flush thoroughly.
8. De-aerate boiler feed-water (particularly if large amount of new water is used).
9. Clean strainers ahead of unit.
10. Adequately vent each unit to remove air from system.

REPLACEMENT PARTS

For ease of identification when ordering replacement parts or contacting the factory about your unit, please quote the Unit Type and unit Serial Number. This information can be found on the serial plate attached to your unit (see Figure 6.1 and Figure 10.2).

When a component part fails, a replacement part should be obtained through our Parts Department. If the part is considered to be under warranty, the following details are required to process this requirement:

1. Full description of part required, including unit part number, if known.
2. The original equipment serial number.
3. An appropriate purchase order number.

Figure 10.1 – Model Nomenclature

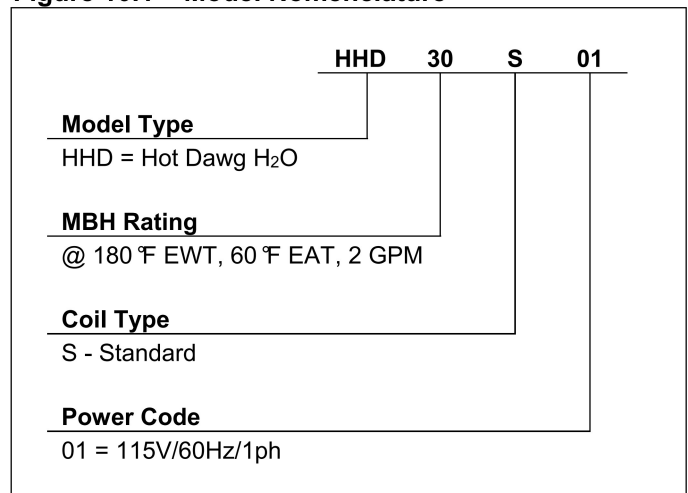
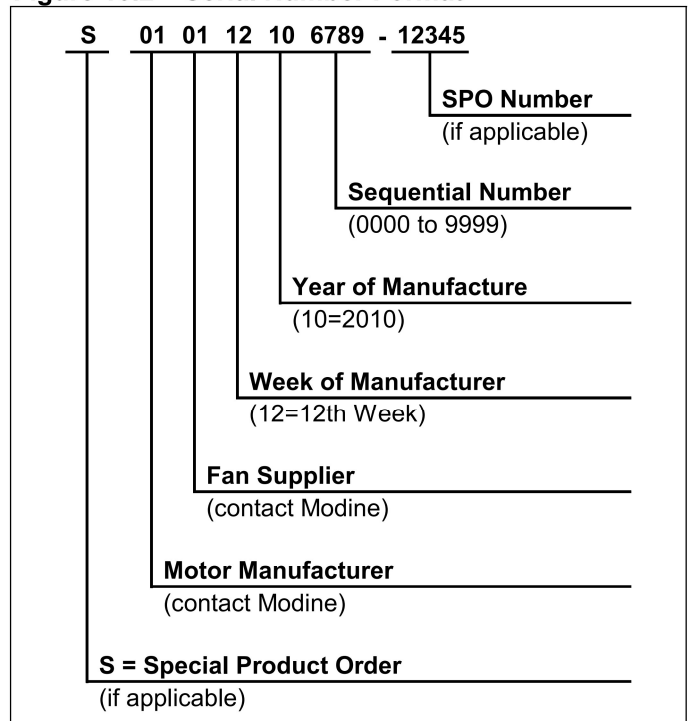

Figure 10.2 – Serial Number Format



THIS PAGE INTENTIONALLY LEFT BLANK

THIS PAGE INTENTIONALLY LEFT BLANK

Seller warrants its products to be free from defects in material and workmanship, EXCLUSIVE, HOWEVER, of failures attributable to the use of materials substituted under emergency conditions for materials normally employed. This warranty covers replacement of any parts furnished from the factory of Seller, but does not cover labor of any kind and materials not furnished by Seller, or any charges for any such labor or materials, whether such labor, materials or charges thereon are due to replacement of parts, adjustments, repairs, or any other work done. This warranty does not apply to any equipment which shall have been repaired or altered outside the factory of Seller in any way so as, in the judgment of Seller, to affect its stability, nor which has been subjected to misuse, negligence, or operating conditions in excess of those for which such equipment was designed. This warranty does not cover the effects of physical or chemical properties of water or steam or other liquids or gases used in the equipment.

BUYER AGREES THAT SELLER'S WARRANTY OF ITS PRODUCTS TO BE FREE FROM DEFECT IN MATERIAL AND WORKMANSHIP, AS LIMITED HEREIN, SHALL BE IN LIEU OF AND EXCLUSIVE OF ALL OTHER WARRANTIES, EITHER EXPRESS OR IMPLIED, WHETHER ARISING FROM LAW, COURSE OF DEALING, USAGE OF TRADE, OR OTHERWISE, **THERE ARE NO OTHER WARRANTIES, INCLUDING WARRANTY OF MERCHANTABILITY OR FITNESS FOR PURPOSE, WHICH EXTEND BEYOND THE PRODUCT DESCRIPTION CONFIRMED BY BUYER AND SELLER AS OF THE DATE OF FINAL AGREEMENT.**

This warranty is void if the input to the product exceeds the rated input as indicated on the product serial plate by more than 5% on gas-fired and oil-fired units, or if the product in the judgment of SELLER has been installed in a corrosive atmosphere, or subjected to corrosive fluids or gases, been subjected to misuse, negligence, accident, excessive thermal shock, excessive humidity, physical damage, impact, abrasion, unauthorized alterations, or operation contrary to SELLER'S printed instructions, or if the serial number has been altered, defaced or removed.

BUYER AGREES THAT IN NO EVENT WILL SELLER BE LIABLE FOR COSTS OF PROCESSING, LOST PROFITS, INJURY TO GOODWILL, OR ANY OTHER CONSEQUENTIAL OR INCIDENTAL DAMAGES OF ANY KIND RESULTING FROM THE ORDER OR USE OF ITS PRODUCT, WHETHER ARISING FROM BREACH OF WARRANTY, NONCONFORMITY TO ORDERED SPECIFICATIONS, DELAY IN DELIVERY, OR ANY LOSS SUSTAINED BY THE BUYER.

BUYER'S REMEDY FOR BREACH OF WARRANTY, EXCLUSIVE OF ALL OTHER REMEDIES PROVIDED BY LAW, IS LIMITED TO REPAIR OR REPLACEMENT AT THE FACTORY OF SELLER, ANY COMPONENT WHICH SHALL, WITHIN THE APPLICABLE WARRANTY PERIOD DEFINED HEREIN AND UPON PRIOR WRITTEN APPROVAL, BE RETURNED TO SELLER WITH TRANSPORTATION CHARGES PREPAID AND WHICH THE EXAMINATION OF SELLER SHALL DISCLOSE TO HAVE BEEN DEFECTIVE; EXCEPT THAT WHEN THE PRODUCT IS TO BE USED BY BUYER AS A COMPONENT PART OF EQUIPMENT MANUFACTURED BY BUYER, BUYER'S REMEDY FOR BREACH, AS LIMITED HEREIN, SHALL BE LIMITED TO ONE YEAR FROM DATE OF SHIPMENT FROM SELLER. FOR GAS-FIRED PRODUCTS INSTALLED IN HIGH HUMIDITY APPLICATIONS AND UTILIZING STAINLESS STEEL HEAT EXCHANGERS, BUYER'S REMEDY FOR BREACH, AS LIMITED HEREIN, SHALL BE LIMITED TO TEN YEARS FROM DATE OF SHIPMENT FROM SELLER.

These warranties are issued only to the original owner-user and cannot be transferred or assigned. No provision is made in these warranties for any labor allowance or field labor participation. Seller will not honor any expenses incurred in its behalf with regard to repairs to any of Seller's products. No credit shall be issued for any defective part returned without proper written authorization (including, but not limited to, model number, serial number, date of failure, etc.) and freight prepaid.

OPTIONAL SUPPLEMENTAL WARRANTY

Provided a supplemental warranty has been purchased, Seller extends the warranty herein for an additional four (4) years on certain compressors. Provided a supplemental warranty has been purchased, Seller extends the warranty herein for an additional four (4) years or nine (9) years on certain heat exchangers.

EXCLUSION OF CONSUMABLES & CONDITIONS BEYOND SELLER'S CONTROL

This warranty shall not be applicable to any of the following items: refrigerant gas, belts, filters, fuses and other items consumed or worn out by normal wear and tear or conditions beyond Seller's control, including (without limitation as to generality) polluted or contaminated or foreign matter contained in the air or water utilized for heat exchanger (condenser) cooling or if the failure of the part is caused by improper air or water supply, or improper or incorrect sizing of power supply.

Component Applicable Models	"APPLICABLE WARRANTY PERIOD"
<u>Heat Exchangers</u> Gas-Fired Unit Heaters except PSH/BSH	TEN YEARS FROM DATE OF FIRST BENEFICIAL USE BY BUYER OR ANY OTHER USER, WITHIN TEN YEARS FROM DATE OF RESALE BY BUYER OR ANY OTHER USER, WITHIN TEN YEARS FROM DATE OF RESALE BY BUYER IN ANY UNCHANGED CONDITION, OR WITHIN ONE HUNDRED TWENTY-SIX MONTHS FROM DATE OF SHIPMENT FROM SELLER, WHICHEVER OCCURS FIRST
<u>Heat Exchangers</u> Low Intensity Infrared Units <u>Compressors</u> Condensing Units for Cassettes	FIVE YEARS FROM DATE OF FIRST BENEFICIAL USE BY BUYER OR ANY OTHER USER, WITHIN FIVE YEARS FROM DATE OF RESALE BY BUYER OR ANY OTHER USER, WITHIN FIVE YEARS FROM DATE OF RESALE BY BUYER IN ANY UNCHANGED CONDITION, OR WITHIN SIXTY-SIX MONTHS FROM DATE OF SHIPMENT FROM SELLER, WHICHEVER OCCURS FIRST
<u>Burners</u> Low Intensity Infrared Units <u>Other</u> Components excluding Heat Exchangers, Coils, Condensers, Burners, Sheet Metal	TWO YEARS FROM DATE OF FIRST BENEFICIAL USE BY BUYER OR ANY OTHER USER, WITHIN TWO YEARS FROM DATE OF RESALE BY BUYER IN ANY UNCHANGED CONDITION, OR WITHIN THIRTY MONTHS FROM DATE OF SHIPMENT FROM SELLER, WHICHEVER OCCURS FIRST
<u>Heat Exchangers/Coils</u> Indoor and Outdoor Duct Furnaces and System Units, PSH/BSH, Steam/Hot Water Units, Oil-Fired Units, Electric Units, Cassettes, Vertical Unit Ventilators <u>Compressors</u> Vertical Unit Ventilators <u>Burners</u> High Intensity Infrared Units <u>Sheet Metal Parts</u> All Products	ONE YEAR FROM DATE OF FIRST BENEFICIAL USE BY BUYER OR ANY OTHER USER, WITHIN ONE YEAR FROM DATE OF RESALE BY BUYER IN ANY UNCHANGED CONDITION, OR WITHIN EIGHTEEN MONTHS FROM DATE OF SHIPMENT FROM SELLER, WHICHEVER OCCURS FIRST



Modine Manufacturing Company
1500 DeKoven Avenue
Racine, WI 53403
Phone: 1.800.828.4328 (HEAT)
www.modine.com