

**Operation**

The *Macon* valve is designed to save energy by controlling hot water or low pressure steam heat in freestanding radiators, convectors, baseboards, fan coil units and the like in a loop, a zone or a unit. The valve, coupled with a *Macon* operator, provides a reliable automatic modulating unit. As room temperature drops, the *Macon* valve opens to allow more hot water or steam to flow through the radiator, thus allowing more heat into the room. When the room approaches the selected temperature, the operator causes the valve to begin closing off the flow of hot water or steam. This continued monitoring of the temperature is fully automatic, using no electricity whatsoever. The *Macon* valve can be equipped with any wide variety of *Macon* operators.

**Features**

- Compact dimensions
- Replaceable insert
- Stainless steel spindle
- Individual room control
- Easy one-trade installation
- Fuel savings up to 30%
- Prevents over- and under-heating
- Helps balance the heating system
- Same valve used for hot water or low pressure steam
- All NPT are forged brass nickel-plated
- Minimizes or eliminates expansion noises
- Suitable for nearly any hydronic heating application
- Operators can be changed without draining the system
- Shipped with a protective cap that can be used to control heating during the installing period

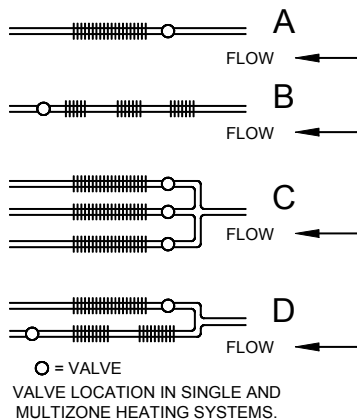

Vertical angle valve with straight nipple. NPT - female inlet, male union outlet.



- N10637 - 1/2"
- N10657 - 3/4"
- N10677 - 1"
- N10697 - 1-1/4"

Straight valve with straight nipple. NPT - female inlet, male union outlet.



- N10737 - 1/2"
- N10757 - 3/4"
- N10777 - 1"
- N10797 - 1-1/4"

Horizontal angle valve with straight nipple. NPT - female inlet, male union outlet.



- N10837 - 1/2"
- N10857 - 3/4"
- N10877 - 1"
- N10897 - 1-1/4"

Sweat valve with female inlet and outlet.



- N10930 - 1/2"
- N10950 - 3/4"
- N10970 - 1"

Fail closed valves also available, consult factory. All Macon valves and thermostats conform to ASHRAE Standard 102P-1983 and European Standard EN 215/1215. We are also ISO 9001 certified (1994) and ISO 14001 certified (1998).



## DATA - Macon Valves for NT Series

**Vertical Angle NPT**

1/2", 3/4", 1", 1-1/4"

**Straight NPT**

1/2", 3/4", 1", 1-1/4"

**Horizontal Angle NPT**

1/2", 3/4", 1", 1-1/4"

**Straight Female Sweat**

1/2", 3/4", 1"

**Disc Material:** EPDM

**Body Styles:** Straightway or angle

**Maximum steam pressure:** 15 psig

**Maximum static pressure:** 145 PSI

**Maximum water temperature:** 250°F

**Body tappings:** Female inlet, male union outlet, Female sweat

**Body Material:** Forged brass, NPT valves are nickel-plated

**Max. Differential pressure:** 20 psi H<sub>2</sub>O, refer to thermostat specs

**Suggested Differential Pressure** = 0.5 to 2.9 psi

**Overall Height:** Add thermostat dimensions less 1/4"

**Macon NT Series Valves are in an open position when no operator is attached.**

<b>CV:</b>	1/2"	= 1.8
	3/4"	= 2.5
	1"	= 2.74
	1-1/4"	= 3.5

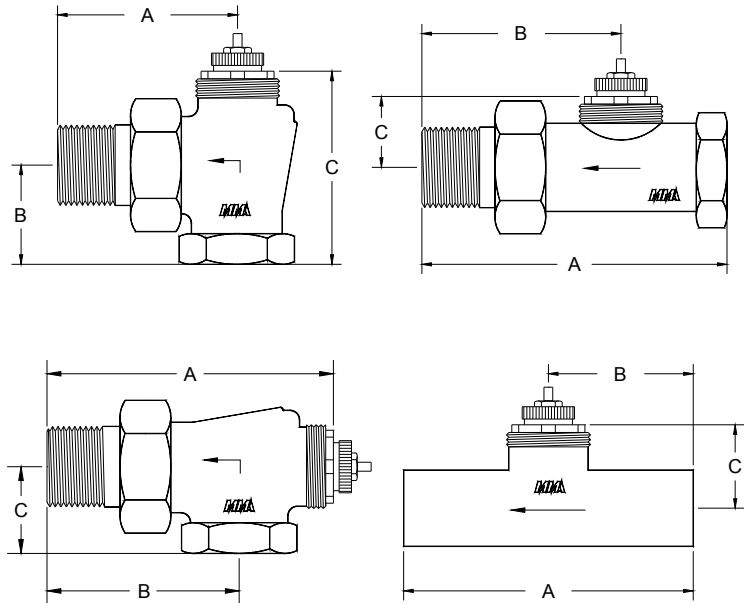

### DIMENSIONS

#### VERTICAL ANGLE

BODY #	SIZE	A	B	C
N10637	1/2"	2-1/4"	1"	1-3/4"
N10657	3/4"	2-1/2"	1-1/8"	2-1/8"
N10677	1"	3"	1-3/8"	2-1/4"
N10697	1-1/4"	3-1/4"	1-3/4"	2-3/4"

#### STRAIGHTWAY

BODY #	SIZE	A	B	C
N10737	1/2"	3-1/2"	2-1/16"	1"
N10757	3/4"	4"	2-1/2"	1"
N10777	1"	4-5/8"	2-15/16"	1"
N10797	1-1/4"	5-1/4"	3-3/8"	1-1/8"

#### HORIZONTAL ANGLE

BODY #	SIZE	A	B	C
N10837	1/2"	3-3/8"	2-3/16"	1-1/2"
N10857	3/4"	3-3/4"	2-1/2"	1-1/4"
N10877	1"	4-3/16"	3"	1-3/8"
N10897	1-1/4"	4-3/4"	3-1/4"	1-7/8"

#### SWEAT VALVES

BODY #	SIZE	A	B	C
N10930	1/2"	2-3/16"	1-3/32"	1"
N10950	3/4"	2-11/16"	1-11/32"	7/8"
N10970	1"	3-5/32"	1-9/16"	1"

