

### Description and Application

These compact but powerful direct-coupled ControlSet® actuators provide two-position, tri-state, or proportional control for dampers or valves in HVAC systems. Efficient, durable, capacitor-driven fail-safe with switch-selectable direction provides consistent torque in both powered and fail-safe modes. A patent-pending noise reducer provides whisper-quiet operation in both modes. A minimum torque of 25 (MEP-42xx), 45 (MEP-45xx), or 90 (MEP-49xx) in.-lb. is available over the 95° angular rotation.

MEP-4xx2 **proportional** models accept either a 0–10 or 2–10 VDC control signal input from a thermostat, controller, or building automation system. “**Anti-jitter**” circuitry significantly reduces hunting and needless wear (from unnecessary miniscule position changes caused by undamped analog input signals) on the actuator, valve, or damper components. A user-initiated, **auto-mapping** feature provides more precise equipment control by reassigning the input signal range over a reduced rotation range. These models also feature a switch-selectable, 0–5 or 0–10 (or 1–5 or 2–10) VDC voltage **feedback** output that is proportional to the actuator position.

MEP-4xx1 **tri-state/two-position** (four-wire) models are designed for use with floating thermostats or controllers. MEP-4xx4/4xx5 **two-position** (two-wire) models are available in 24 VAC/VDC or 100–240 VAC models.

MEP-4x7x models also have one fully adjustable, built-in SPDT **auxiliary switch** for remote position indication or equipment interface. MEP-497x models include a second fixed switch at 10° from full CW direction. A three-foot cable is included with the switch(es).

MEP-4xxxV actuators have brackets with a patent-pending quick-mounting mechanism. See [\(Quick-Mounting\) “V” Models Valve Cross-Reference on page 5](#) for more information.

All actuators mount directly to 1/4- to 5/8-inch (6 to 16 mm) round shafts or 1/4- to 7/16-inch (6 to 11 mm) square shafts, eliminating the need for expensive and complicated linkages. A non-rotation bracket, to prevent lateral movement, is included with each actuator. A gear disengagement button allows easy manual positioning of the actuator.

(Size Shown Relative to a Quarter)



### Features

- ◆ Efficient, durable, capacitor-driven fail-safe option with switch-selectable direction provides consistent torque in both powered and fail-safe modes
- ◆ The fail-safe option, on proportional and tri-state models, can be turned off temporarily for testing purposes or permanently if desired
- ◆ Proportional models include “anti-jitter” circuitry, optional auto-mapping of the full input signal range over a reduced actuator stroke, and switch-selectable 0/1–5 or 0/2–10 VDC feedback
- ◆ MEP-4x7x models have one fully adjustable, built-in SPDT auxiliary switches, and MEP-497x models include a second fixed switch at 10° from full CW direction
- ◆ Connections are made on either fixed terminals that accept 12–26 AWG wiring or prewired 3-foot, 18 AWG cable(s)
- ◆ Direct mounting to standard shaft sizes, gear disengagement button, and adjustable mechanical end stop
- ◆ Patent-pending valve body quick-mount option on MEP-4xxxV models

**NOTE:** For similar actuators without fail-safe, see the [MEP-4000/4800 Series Data Sheet](#) and the [MEP-4201/4501/4901 Data Sheet](#).

## Models

Model Number*	Torque, in-lbs. (N•m)	Control Type	Operating Voltage	Auxiliary Switches***	Voltage Feedback	Electrical Connections****	FCC and ICES-003	Powered and Fail-Safe Running Time (seconds/90°)
MEP-4254 (V)*	25 (2.82)	Two-Position (2-wire) <sup>†</sup>	24 VAC/ VDC**	0	None	Terminals	Class A	<35 and <30
MEP-4274				1 Adjustable		2 Cables		
MEP-4255 (V)*		Tri-state/ 2-Position (4-wire) <sup>†</sup>	100–240 VAC	0		1 Cable	Class B	<25 and <30
MEP-4275				1 Adjustable		2 Cables		
MEP-4251 (V)*		Proportional 2–10 or 0–10 VDC	24 VAC/ VDC	0		0/1–5 or 0/2–10 VDC	Terminals	<35 and <30
MEP-4252 (V)*				1 Adjustable			2 Cables	
MEP-4272								
MEP-4554 (V)*	45 (5)	Two-Position (2-wire) <sup>†</sup>	24 VAC/ VDC**	0	None	Terminals	Class A	<35 and <30
MEP-4574				1 Adjustable		2 Cables		
MEP-4555 (V)*		Tri-state/ 2-Position (4-wire) <sup>†</sup>	100–240 VAC	0		1 Cable	Class B	<25 and <30
MEP-4575				1 Adjustable		2 Cables		
MEP-4551 (V)*		Proportional 2–10 or 0–10 VDC	24 VAC/ VDC	0		0/1–5 or 0/2–10 VDC	Terminals	<35 and <30
MEP-4552 (V)*				1 Adjustable			2 Cables	
MEP-4572								
MEP-4954	90 (10)	Two-Position (2-wire) <sup>†</sup>	24 VAC/ VDC**	0	None	Terminals	Class A	<45 and <40
MEP-4974				1 Adj., 1 Fixed		2 Cables		
MEP-4955		Tri-state/ 2-Position (4-wire) <sup>†</sup>	100–240 VAC	0		1 Cable	Class B	<30 and <40
MEP-4975				1 Adj., 1 Fixed		2 Cables		
MEP-4951		Proportional 2–10 or 0–10 VDC	24 VAC/ VDC	0		0/1–5 or 0/2–10 VDC	Terminals	<45 and <40
MEP-4952				1 Adj., 1 Fixed			2 Cables	
MEP-4972								

\*MEP-4xxxV models (e.g., MEP-4254V or MEP-4552V) have the quick-mount option. MEP-42xxV are for use on 1/2" and 3/4" ball valves; MEP-45xxV are for use on 1" to 3" ball valves. Only some models have the "V" option.

\*\*Two-position 24 VAC/VDC MEP-4xx4 models are FCC Class A, Part 15, Subpart B and complies with Canadian ICES-003 Class A. All other models are Class B. For other approvals, which apply to all models, see [Specifications on page 3](#).

\*\*\*One auxiliary switch is adjustable 0–90°. On MEP-497x models, the second switch is fixed at 10° from full CW direction (Blue is connected to Orange in the 0–10° range, and Blue is connected to Green 11–90°).

\*\*\*\*Connections are made on either fixed terminals that accept 12–26 AWG wiring or (for line-voltage models and/or models with an auxiliary switch) prewired 3-foot, 18 AWG cable(s).

<sup>†</sup>For two-position and tri-state, the "control signal" is the same as the operating voltage.

<sup>‡</sup>After initial power-up, proportional models delay enabling motor operation approximately 30 seconds until the capacitors are charged. No actuator rotation will take place for at least the first 30 seconds.

**NOTE:** See also [\(Quick-Mounting\) "V" Models Valve Cross-Reference on page 5](#) for cross-reference information.

**NOTE:** The above chart lists the differences among models. Supply power, supply frequency, transformer sizing, fail-safe, angular rotation, noise level, mounting, dimensions, weight, enclosure material, position indication, servicing, quality standard, warranty, and environmental limits are the same for all models. See [Specifications on page 3](#).

## Specifications

<b>Control Signal</b>		<b>Brackets</b>	Non-rotation bracket HMO-4001 (supplied with MEP-4x7x and all MEP-49xx models) or HMO-4002 (supplied with MEP-425x and MEP-455x); HPO-5073 or HPO-5074 required for mounting to valves
Proportional	0 to 10 VDC or 2 to 10 VDC, switch selectable		
Tri-state/2-Pos.	See Supply Voltage		
Two-position	See Supply Voltage		
<b>Supply Voltage</b>		<b>Connections</b>	
Low Voltage	24 VDC/VAC (+20%/–15%), Class 2 only (MEP-4xx1/4xx2/4xx4)	Power/Signal	Fixed wire clamp type terminal block, 12–26 AWG, copper, or prewired 3-foot, 18 AWG cable (see <a href="#">Models on page 2</a> )
Line Voltage	100–240 VAC (MEP-4xx5)	Aux. Switch(es)	3-foot 18 AWG cable
<b>Supply Frequency</b>	50/60 Hz for VAC operation	<b>Dimensions</b>	6.000 x 2.812 x 3.406 inches (152.4 x 71.4 x 86.5 mm)—see also <a href="#">Dimensions on page 4</a>
<b>Supply Power</b>	6 VA normal operation, 19 VA peak initializing	<b>Weight</b>	1.5 lb. (0.68 kg)
<b>Transformer Sizing</b>	20 VA	<b>Enclosure</b>	UL94-5VA Flame-retardant plastic
<b>Initialization Time</b>	30 seconds (on power-up) for proportional models only	<b>Position Indication</b>	Visual indicator, 0° to 95°
<b>Feedback Output</b>	0/1 to 5 VDC or 0/2 to 10 VDC (switch selectable, proportional models only)	<b>Servicing</b>	Maintenance free
<b>Auxiliary Switches</b>		<b>Quality Standard</b>	ISO 9001
Rating	SPDT 6 A resistive load (3 A motor load) @ 250 VAC	<b>Warranty</b>	5 years (from mfg. date code)
MEP-427x/457x	1 switch, adjustable 0 to 90°	<b>Approvals</b>	UL 873 Temperature Indicating and Regulating Equipment; FCC Class B, Part 15, Subpart B and complies with Canadian ICES-003 Class B ( <b>except for MEP-4xx4</b> models, which are Class A)
MEP-497x	2 switches; 1 adjustable 0 to 90° and 1 fixed at 10° from full CW direction	<b>Environmental Limits</b>	
<b>Fail-Safe Control</b>	Switch selectable, CW/OFF/CCW on proportional and tri-state models, CW/CCW on 2-position models	Operating	–22 to 131° F (–30 to 55° C)
<b>Fail-Safe Type</b>	(Electronic) capacitor driven	Shipping	–40 to 176° F (–40 to 80° C)
<b>Angular Rotation</b>	0 to 95°, fully adjustable with mechanical stop	Humidity	5 to 95% RH (non-condensing)
<b>Running Time</b>	See <a href="#">Models on page 2</a>		
<b>Torque</b>		<b>NOTE:</b>	See also <a href="#">Dimensions on page 4</a> .
MEP-42xx	25 in-lbs. (2.82 N•m)	<b>NOTE:</b>	Before August 2015 these actuators had 2–10 VDC inputs and 1–5 or 2–10 VDC feedback (only). Starting in August 2015, 0–10 VDC inputs and 0–5 or 0–10 VDC feedback were also available and switch-selectable.
MEP-45xx	45 in-lbs. (5 N•m)	<b>NOTE:</b>	When the 0–10 VDC input is selected, selectable feedback options are 0–5 or 0–10 VDC. When the 2–10 VDC input is selected, feedback options are 1–5 or 2–10 VDC.
MEP-49xx	90 in-lbs. (10 N•m)		
<b>Noise Level</b>	< 45 dBA max. at 1 meter		
<b>Mounting</b>	Direct to 1/4 to 5/8 inches (6 to 16 mm) round or 1/4 to 7/16 inches (6 to 11 mm) square shaft by adjustable “V” bolt and supplied non-rotation bracket; minimum recommended damper shaft length is 1-5/8 inches		

# Dimensions

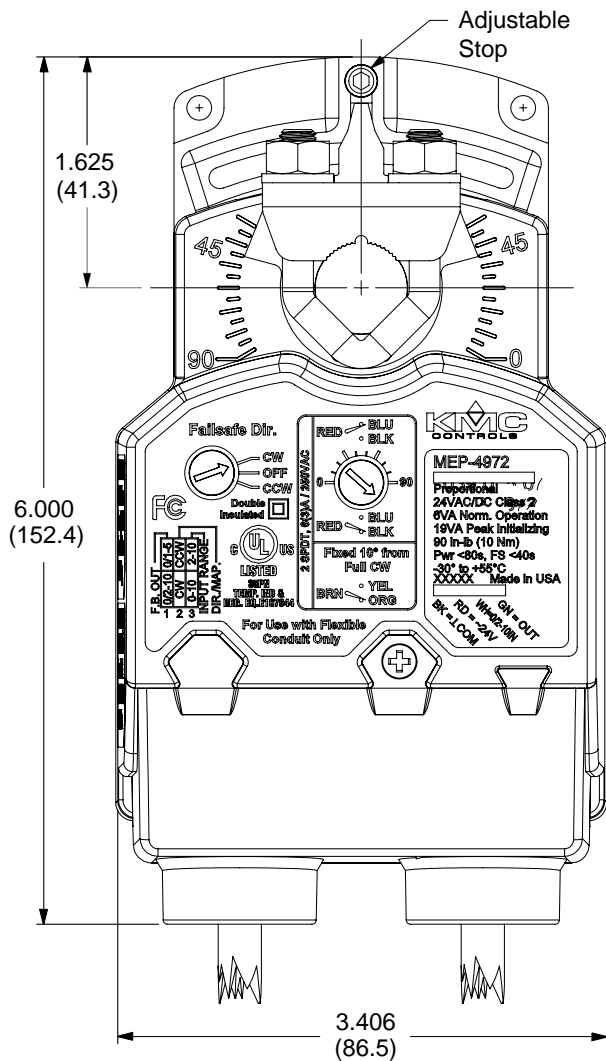

Dimensions are in inches (mm)

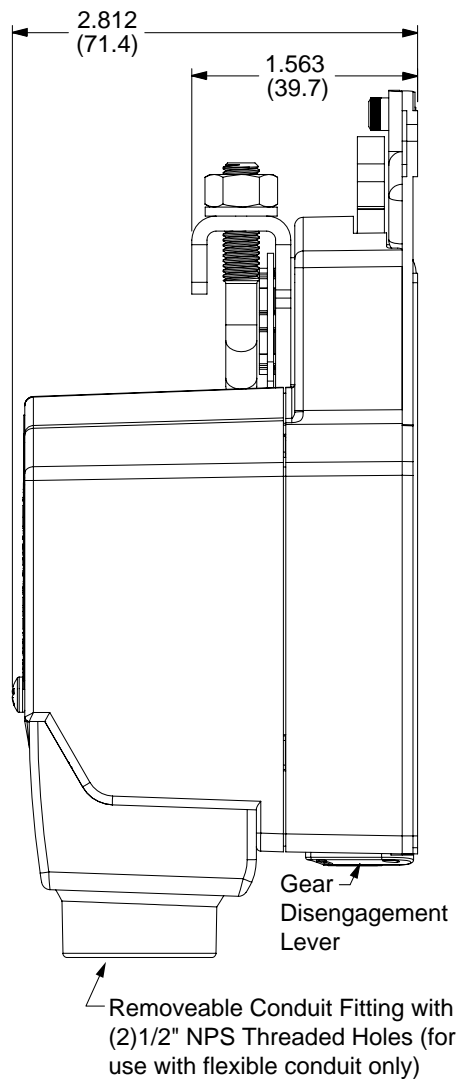

**NOTE:** The two holes at the top of the actuator are NOT for use in direct-coupled applications. (They are for remote mounting, such as with the optional HLO-4001 Crank Arm Kit.) For mounting to valves, see the appropriate valve installation guide.

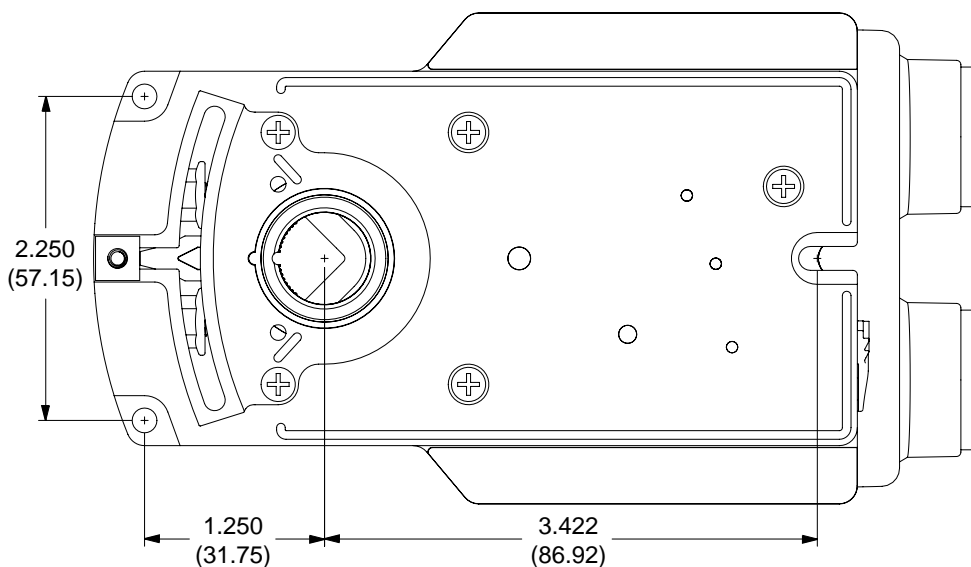

## (Quick-Mounting) "V" Models Valve Cross-Reference

MEP-4xxxV actuators have brackets with a patent-pending, **quick-mounting** mechanism that mounts directly on VFB-43...BC and VFB-46...BC series valve bodies. See the **HPO-5074 installation guide** and the **VEB-43** and **VEB-46** series data sheets for additional information.

NOTE: "V" actuators were installed in VEB-43...CF, VEB-43...CK, VEB-46...CF, and VEB-46...CK valves starting in mid-June 2011 (date codes 11166 and later). Replacement (non-fail-safe) actuators for valves before this date code would be MEP-4002/4003.

With the **HPO-5074 kit**, MEP-4xxxV actuators can be mounted on the following KMC and other valve bodies:

"V" Actuator Installed on VEB-43 Series Valve Body with HPO-5074 Quick-Mount Adapter Kit

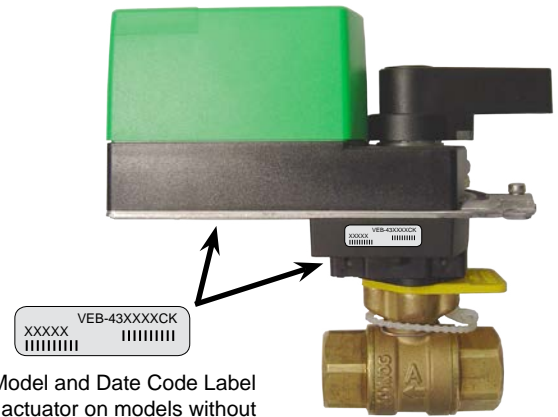

Valve Model and Date Code Label (below actuator on models without "V" actuators or on the side of the valve on models with "V" Actuators)

Typical Application	3-Way H/C Water	2-Way H/C Water	2-Way PIC-V H/C Water
KMC Valve Body	VFB-46__BC*	VFB-43__BC*	N/A
KMC Valve	VEB-46__B__	VEB-43__B__	
Valve Solutions (VSI)	UR3 Series	UR2 Series	SPV Series
Griswold	UR3 Series	UR2 Series	SPV Series
Delta Control Products	ST Series	ST Series	ATI Series
Honeywell	VBN3 Series	VBN2 Series	N/A
Siemens	599 Series	599 Series	

\*VFB-4\_\_BC valve bodies come with the HPO-5074 already installed.

NOTE: When replacing a KMC MEP-5xxx actuator with an MEP-4xxx actuator on a ball valve, two options are:

- Using an MEP-4xxxV with an **HPO-5074** kit.
- Using an MEP-4xxx (non-V models) with an **HMO-4004** kit.

## Accessories and More Information

For **mounting, wiring, auxiliary switches, feedback/direction selectors, actuator/signal range reset (auto-mapping)**, and other information, see the [MEP-4200/4500/4900 Series Installation Guide](#).

For **torque selection, accessories, troubleshooting**, and other information, see the [MEP-4xxx Applications Guide](#).

For **sample proportional single-zone heating/cooling valve applications using the CTE-5202** electronic thermostat, see the [CTE-5202 Applications Guide](#).

**NOTE:** When replacing a KMC MEP-5xxx actuator with an MEP-4xxx actuator:

- If on a **damper**, use a non-V model of the MEP-4xxx.
- If on a **ball valve**, two options for replacement are: (1) the MEP-4xxxV with an **HPO-5074** kit **OR** (2) the MEP-4xxx (non-V models) with an **HMO-4004** kit.

### KMC Controls, Inc.

19476 Industrial Drive

New Paris, IN 46553

574.831.5250

[www.kmcccontrols.com](http://www.kmcccontrols.com)

[info@kmcccontrols.com](mailto:info@kmcccontrols.com)